

A 10389

ROUND FRONT SNACK

AMBIENT & REFRIGERATED SERVICE MANUAL

MODELS:

3 WIDE - 3168, 3168A

4 WIDE - 3169, 3169A

5 WIDE - 3170, 3170A

TABLE OF CONTENTS

SPECIFICATIONS.....	1	REFRIGERATION OPTION.....	10
INTRODUCTION.....	2	PREVENTIVE MAINTENANCE.....	13
UNPACKING.....	3	PARTS ORDERING PROCEDURE.....	14
INSTALLATION.....	4	BEFORE CALLING FOR SERVICE.....	14
LOADING PRODUCTS.....	4	SCHEMATIC.....	15
TRAY ADJUSTMENTS.....	6		
CONTROLLER FUNCTIONS.....	8		

SPECIFICATIONS

DIMENSIONS

MODEL	3168, 3168A	3169, 3169A	3170, 3170A
TYPE	3 Wide	4 Wide	5 Wide
WIDTH	29.3 in. (74 cm)	35.2 in. (89 cm)	41 in (104 cm)
WEIGHT	577 lbs. (262 kg)	648 lbs. (294 kg)	778 lbs. (353 kg)
DEPTH	35.5 in. (87 cm)		
HEIGHT	72 in. (183 cm)		

FACTORY CONFIGURATION

SELECTION	24 Select Expandable to 36	36 Select Expandable to 48	40 Select Expandable to 60

ELECTRICAL

VOLTAGE	115 VAC	230 VAC
CYCLE	60 Hz	50 Hz
AMPS	7.5 Amps	3.7 Amps
TRANSFORMER	24 VAC	24 VAC

REFRIGERATION

HORSEPOWER	1/3 Hp
TYPE	Hermetically Sealed
CONTROLS	Electronic
REFRIGERANT	R-134a
CHARGE	5.9 Ounces (167 grams)

COINAGE	
MDB VERSION	Any MDB peripheral device
INTERNATIONAL	Executive Mech
DOMESTIC	Any MDB peripheral device
VENDOR OPERATION	
LOCATION	Suitable for indoor use only. This appliance is not suitable for installation on an area where a water jet could be used.
SOUND LEVEL	Produces less than 70dBA during normal operation
RECOMMENDED OPERATING TEMPERATURE	Between 32° and 100° Fahrenheit (0° and 37.8° Celsius)

INTRODUCTION

This manual contains instructions, service and installation guidelines for the **Refrigerated Round Front** product line.

All **Refrigerated Round Front** models are equipped with an electronic control system. All programming of the vend functions, pricing and features are done at the controller. Changes can be made without any additional accessories or remote parts.

Selections can be priced individually from \$.05 to \$999.95 in five cent increments (U.S. currency). When adapted to accept international or foreign currency, the maximum vend price will be 255 times the smallest denomination of coin being accepted.

Cash accountability records Total Cash transactions and Total Vend cycles performed by the vendor. Information for individual selections, complete rows or total machine can be compiled and used for inventory and ordering records.

Electrical malfunctions are recorded and displayed when the machine is placed in Service Mode. Non-functional motors or selections are indicated. Each selection has an individual motor. Functional selections will continue to operate if other motors become non-functional.

The vending sequence is "first-in, first-out" for each selection, eliminating the need for stock rotation to maintain fresh products in the vending area.

Each **Refrigerated Round Front** vendor has the capability of supporting a "satellite" vending machine, such as a Can Vendor or Food Merchandiser (Menu Mart II). The satellite vendor utilizes the **Refrigerated Round Front** vendor's existing controller, coin mechanism, bill validator and keypad to perform the vend functions they require. Refer to the satellite vendor's service manual for detailed installation instructions.

On air-conditioned Round Front models the temperature is controlled electronically.

This manual should be read thoroughly. Become familiar with the functions of all components and of the features that are available. The initial set-up of a vending machine is a very important step of insuring that the equipment operates in a trouble-free manner. Following the instructions at the initial installation of the machine will avoid service problems and minimize set-up time.

Access to the service area of this machine should only be permitted to individuals having knowledge and practical experience of the machine, in particular as far as safety and hygiene are concerned.

If you have any questions concerning the information in the manual, replacement parts or the operation of the vendor, then please contact your local distributor or:

VendNet
165 North 10th Street
Waukee, IA 50263

Phone: (515) 274-3641
Parts Fax: (515) 274-5775
Sales Fax: (515) 274-0390
Email: vendnet@vendnetusa.com

UNPACKING

This machine was thoroughly inspected before leaving the factory and the delivering carrier has accepted this vendor as their responsibility. Note any damage or irregularities at the time of delivery and report them to the carrier. Request a written inspection report from the claims inspector to file any claim for damage. File the claim with the carrier (not the manufacturer) within 15 days after receipt of the machine.

Carefully remove the outside packing material so as not to damage the finish or exterior of the machine. Inspect the machine for concealed shipping damage. Report any damage hidden by the shipping material directly to the delivering carrier on a hidden damage report.

NOTE

If the power supply cord is damaged, it must be replaced by the manufacturer, its service agent or similarly qualified individual in order to avoid hazard.

The **Model and Serial numbers** are required in order for you to obtain service and parts for your machine. The numbers are on the identification plate located on the backside of the cabinet of the machine. Record the model number and serial number of the vendor on the space provided below. Refer to these numbers on all correspondence and inquiries pertaining to this vendor.

MODEL NUMBER: _____
SERIAL NUMBER: _____

Remove the "Knock-A-Way" support by placing a 2x6 under the vendor. Insert a large screwdriver or prying tool into the groove and split it in two. Turn the leveling screws in as far as possible. See **Figure 1**.

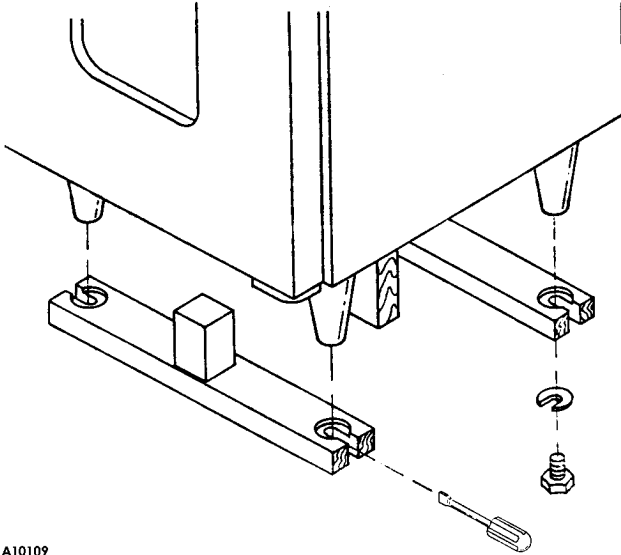

A10109

Figure 1. Remove shipping skids

INSTALLATION

Position the vendor in its place of operation no further than nine (9) feet from the power outlet or receptacle and check that the door will open fully without interference. Leave at least six (6) inches of space between the back of the machine and any wall or obstruction for proper air circulation.

Level the vendor, making sure all levelers are touching the floor. The vendor **must** be level for proper operation and acceptance of coins through the coin mechanism.

Retrieve the keys to the vendor from the coin return cup. Open outer door and remove all internal packing material.

Consult local, state and federal codes and regulations before installation of the vendor.

GROUNDING (EARTHING) & ELECTRICAL

Refer to the Safety Manual and Installation Guidelines manual (P/N 4206816) that shipped in the service package with your machine.

Before connecting the vendor, the integrity of the main electrical supply must be checked for correct polarity, presence of ground (earth) and correct voltage. These checks should be repeated at six (6) month intervals with the routine safety electrical testing of the vendor itself.

If the receptacle is not properly grounded or polarized, you should contact a licensed electrician to correctly polarize and/or ground the receptacle to ensure safe operation.

A noise suppressor has been installed in this machine to compensate for any mains signal noise that could interfere with the normal operation of the controller.

For proper operation of any equipment utilizing electronically controlled components, the equipment should be placed on an isolated or dedicated noise free circuit, properly polarized and grounded.

Refer to Electrical Specifications on this sheet to determine circuit amperage and protection.

LOADING PRODUCTS

To load products, lift the tray slightly and pull forward until the tray stops. The uppermost trays tilt for easier loading.

Load product from front to back making sure all items fit freely between the augers. Do not attempt to force oversize items or packages into the spaces. Do not skip a space. Place the product on the bottom of the compartment on the product augers with the label facing the front of the machine for easy identification by the customer. See **Figure 2**.

The size of the item being vended **must** be larger than the diameter of the auger being used to vend properly. Undersize items could cause vend problems. If the product does not fit the auger properly, use a different pitched auger. See Table 1 for augers available from your distributor or service entity.

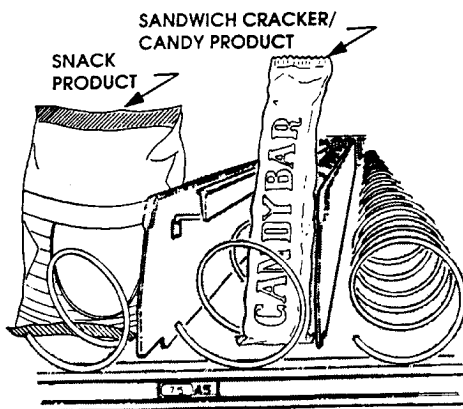

Figure 2. Loading Products

Table 1. Available Augers

TYPE	PRODUCT			PART NUMBER
	WIDTH (INCH)	THICK (INCH)	QTY	
CANDY	2.75	0.50	30	4200272.103309
		0.66	24	4200272.102309
		0.94	18	4200272.101309
		1.19	15	4200272.100309
		1.50	12	4200272.104309
		2.03	9	4200272.105309
SNACK	5.50	1.19	15	4200272.109309
		1.50	12	4200272.108309
		1.81	10	4200272.107309
		2.62	8	4200272.111309
		2.69	7	4200272.110309

TRAY ADJUSTMENTS

By re-timing the augers, difficult to vend items can be dispensed more dependably. By altering tray spacing, larger items can be vended. By changing the tray configuration, different product mixes can be accommodated.

AUGER TIMING

Each auger can be rotated in 20° (degree) increments for a different drop off point. Most items can be vended successfully when the auger end is positioned at the 6 o'clock position.

To change the auger end position:

1. Remove the motor cover. See Figure 3.
2. Raise the motor slightly and pull forward on the auger until it separates from the motor.
3. Rotate the auger to the desired position and re-insert the auger coupling into the motor.
4. Make sure the auger coupling is seated over the vertical rail or retaining rib on the tray.
5. Replace the motor cover making sure it is securely tightened.

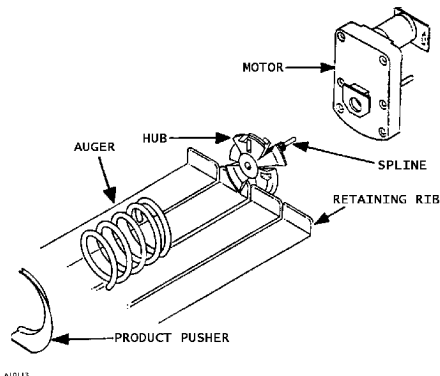

Figure 3. Motor & Auger

TRAY SPACING

The trays can be adjusted up or down in one inch increments to provide additional headroom for vending taller products. When increasing the height in one area, the same amount of room will be lost at the tray above or below the one being adjusted.

3 WIDE & 4 WIDE TRAY SPACING ADJUSTMENTS

1. Pull out the tray to be adjusted until it stops.
2. Disengage the tray harness from its snap-open harness clamp on the right side wall.
3. Disconnect the tray plug from its receptacle on the right hand side wall.
4. Lift up on the front of the tray and pull slightly approximately 1/2 inch (1 cm) forward to clear the tray stop.
5. Lift up on the rear of the tray and remove it from the vendor.
6. Disengage both left and right tray rails from their corresponding slots on the left and right side walls by pulling inward on the bottom front of each rail and lifting its flange out of the slot.
7. Pull each rail forward to disengage its rear tabs from the hole in the rear wall.
8. Re-locate both left and right rails by reversing steps 6 and 7.

Rails must be level from front to back and evenly spaced from top to bottom of each side.

9. Replace the tray by placing its rear rollers on the left and right rails and lifting up on the front of the tray as it is pressed back.
10. Install the tray plug into its receptacle on the right side wall.
11. Re-engage the tray harness into its harness clamp and snap the clamp closed.
12. Test vend the tray in its new position to assure that the tray plug is properly seated.

5 WIDE TRAY SPACING ADJUSTMENTS

1. Pull out the tray to be adjusted until it stops.
2. Locate the harness clamp on the right side wall. See Figure 4.
3. Open the harness clamp by pressing up on the tab.
4. Unplug the "Double D" tray plug from its receptacle on the right side wall.
5. Lift up on the front of the tray and pull slightly approximately .5 inches (1.5 cm) forward to clear the tray stop.
6. Locate the release lever on the left and right tray rails. See Figure 4. Swing the release levers all the way up to unlatch.
7. Lift up on the rear of the tray and remove it from the vendor.
8. Relocate both left and right tray rails from the left and right side walls.
 - a. Remove tray mounting screws.
 - b. Pull each rail forward to disengage its rear tab from the hole in the rear wall. See Figure 5.

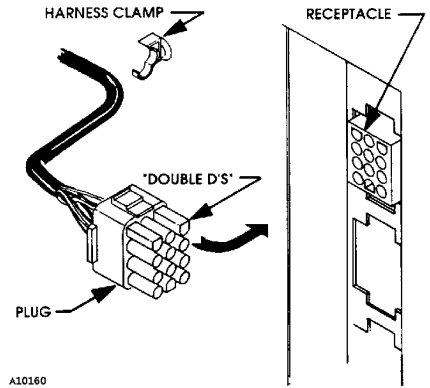

Figure 4. Tray Harness

9. Relocate both left and right rails by reversing step 8. **Rails must be level from front to back and right to left.**
10. Replace the tray by placing its rear rollers on the left and right rails and lifting up on the front of the tray as you push it back.
11. Swing the tray release levers all the way down.
12. Install the tray plug into its receptacle on the right side wall.
13. Re-engage the tray harness into its harness clamp and snap the clamp closed.
14. Test vend the tray in its new position to assure that the tray plug is properly seated.

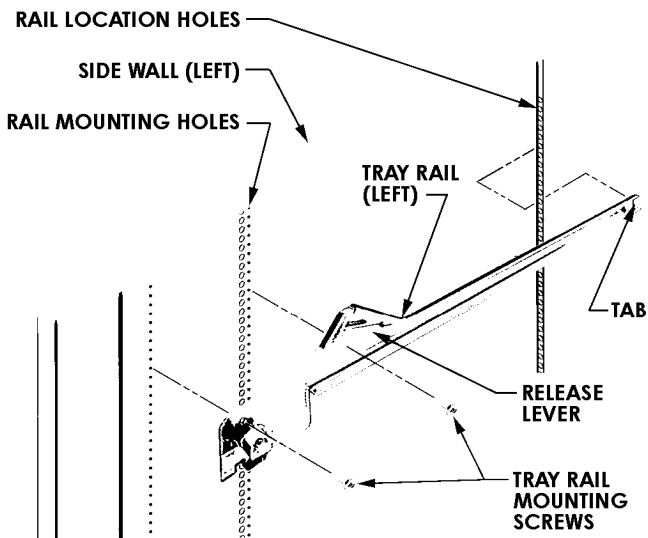

Figure 5. Tray Rails

CANDY TO SNACK

To change the tray configuration, order a conversion kit. See the Parts Ordering Procedure section in this document.

1. Order the conversion kit from your local distributor or service entity.
2. Unplug and remove the tray assembly from the vendor. Place the tray harness in the tray before removal.
3. Remove the motor cover by pulling up on the front edge of the cover to clear the stop and then pull forward on the cover.
4. Remove existing ray divider and discard.
5. Remove existing auger assemblies and discard.
6. Remove the existing "even" numbered motor. This motor will not be needed.
7. Tape or secure the terminals removed from the motor out of your way.
8. Move the "odd" numbered motor to the center slot of the compartment.
9. Install the auger retainer furnished as part of the conversion kit.
10. Install the auger assembly furnished as part of the conversion kit, making sure the motor coupling properly engages the motor and is securely snapped over the vertical rail or retaining rig on the tray.
11. Re-assemble the motor cover removed in step 3.
12. Replace the tray assembly into the vendor making sure that the tray is properly located and latched and connect the tray harness.
13. Set the selection to the desired vend price and adjust the price scroll to the same price. **In large item selections, the selection numbers will be the "odd" numbers. For example, selections C3 and C4 are converted to a single selection, C3.**
14. Test vend the converted selection for proper operation and price settings.

SNACK TO CANDY

To change the tray configuration, order a conversion kit. See Parts Ordering Procedure section of this manual.

1. Order the conversion kit from your local distributor or service entity.
2. Unplug and remove the tray assembly from the vendor. Place the tray harness in the tray before removal.
3. Remove the motor cover by pulling up on front edge of the cover to clear the stop and then pull forward on cover.
4. Remove the existing auger assembly and discard.
5. Remove the auger retainer and discard.
6. Move motor from the center slot to the left slot in the compartment.
7. Add the new motor furnished as part of the conversion kit in the right hand slot of the compartment.
8. Properly wire the motor and switch. Refer to the "Schematic" section for wire colors and locations.
9. Add the divider furnished as part of the conversion kit.
10. Install new auger assemblies furnished as part of the conversion kit, making sure the motor couplings properly engage with the motor and are securely snapped over the vertical rail or retaining rib on the tray.
11. Re-assemble the motor cover removed in step 3.
12. Replace the tray assembly into the vendor making sure that the tray is properly located and latched and connect the tray harness.
13. Set the selections to the desired vend price and adjust the price scrolls to agree.
14. Test vend the converted selections for proper operation and price settings.

CONTROLLER FUNCTIONS

If your machine has the red LED display and shows software version 67093-7, then your machine has the optional F80 Controller. Refer to Service Manual Addendum (P/N 4212859) that shipped with your machine for programming instructions.

The controller information in this manual refers to the 120 Select Controller. If your machine has the blue fluorescent display, then it has the 120 Select Controller. Refer to the 120 Select Controller Software Programming Manual (P/N 4212619) for programming instructions.

SALES MODE

The machine automatically defaults to Sales Mode after the machine is turned on. The vendor accepts deposits, pays out change, and dispenses product to the customer.

DISPLAY CREDIT

If credit has not been established and a selection is made, then the price for that selection is displayed briefly. When money or credit is accepted, then the amount of credit is displayed. If the payout tubes in the coin mechanism or below the low-level sensors, the message "USE CORRECT CHANGE" will scroll.

MAKE SELECTION

If a selection is made and the accumulated credit is greater than or equal to the price of the selection, then a vend attempt will take place. If credit is less than the selection price, the price will be displayed and the message "PLEASE INSERT MORE MONEY".

iVend™ CYCLE

Selections A thru G have been assigned at the factory to be monitored for iVend™ optical sensing. They will have an associated vend operation that differs from the normal vend operation. For 5 milliseconds at the start of a vend, the iVend™ optical sensor will be checked for blockage.

If blocked - the normal home-switch-vend cycle will be used and the optical sensors will be ignored. Both the vend motor and a 9 second vend timeout timer are started.

- The selection motor rotates to the home-switch position.
- If there is a home-switch signal, then the vend is considered successful.
- If after 9 seconds and there is no home-switch signal, then the vend failed. The vend motor is shut down and "MAKE ALTERNATE SELECTION" is displayed. The customer can press selection buttons to activate this or another motor or press the coin return button. **Force Vend is overridden under this vend cycle.**

If not blocked - the iVend™ Sensor System is used. The vend motor and a 9 second timeout timer are started.

- The selection motor rotates to the home-switch position.
- If a product is detected during this time period, then the vend is considered successful.
- If after reaching the home-switch position and a product is not detected, then the vend motor will pause for 1 second while the controller continues to monitor the optical sensor for product delivery.
- If a product is detected during this pause, then the vend is considered successful.
- If a product is not detected, then the controller initiates a second vend cycle and a 9 second timer while continuing to monitor the optical sensor.
 - If a product is detected during the second vend cycle, the motor will be stopped immediately. The vend is considered successful. The 2ND VEND counter is increased by one.
 - If a product is not detected and the motor reaches the home-switch position or if a 9 second timer runs out, then the vend has failed or the selection is sold out. Such a state will trigger the display to show "MAKE ALTERNATE SELECTION" message. The amount of credit is displayed. The customer can press selection buttons to activate this or another motor, or to press the coin return button.

CREDIT & COUNTERS

After a successful vend, the amount of remaining credit will be displayed until all coinage is paid back. Also, the HIST COUNT (total vends count) will be incremented by one (1) and the HIST CASH (total cash count) will be incremented by the price of the vend selection. The counter rollovers occur at 79,999.920 and 99,999.95 respectively. If a product is detected during the second vend cycle, then the 2ND VEND record counter is increased by one. The counters are viewable in the accounting menu as well as through a DEX/UCS download. Refer to the 120 Select Programming Manual (p/n 4212619) for additional information on DEX/UCS fields. The RES COUNT (resettable vend count) will be incremented by one (1). The RES SALES (resettable total cash value) counter will be incremented by the price of the selection vend. The counter rollovers occur at 79,999.920 and 99,999.95 respectively if never reset. **Test vends are not included in the counter totals.**

SERVICE MODE

The Service Mode is used to access the menus to set price, test vend, retrieve accounting information or set custom program settings. If credit exist when entering the Service Mode, it will be restored when the machine is returned to Sales Mode.

SERVICE MODE BUTTON

The Service Mode Button is located near the top right corner of the control cover. Press the button to access the Service Mode features. Press the button again to exit and return to Sales Mode. If no key is pressed within 25 seconds while in Service Mode, then the controller automatically exits to the Sales Mode.

KEYPAD

While in Service Mode, keys **A** through **E** are used to navigate between the modes, menus and sub-menus.

Key Functions while in Service Mode:

- Key **A** = Scrolls up through a menu or sub-menu.
- Key **B** = Enters a menu, sub-menu or routine within a menu.
- Key **C** = Scrolls down through a menu or sub-menu.
- Key **D** = Exits down a level from a menu, sub-menu or routine without making a change.

A		
B		
C		
D		
E		

Figure 6. Key Functions in Service Mode



DISPLAY

The display is located on the front door above the keypad. Watch the display after pressing the Service Mode Button and/or keypad buttons.



BASIC PROGRAMMING

Refer to the basic programming steps below or on the control cover label. Press the Service Mode Button, watch the Display, and navigate the menus using the Keypad.



SET PRICE

STEP	DISPLAY
1 Press Service Mode Button 	DIAGNOSE
2 Press A .	MENU 2
3 Press B .	SERV/CONTR
4 Press C .	PRICE
5 Press B .	ITEM(S)
6 Press B .	SELECT --
7 Press A 1 for selection A1.	SELECT A1
8 Press D .	A1\$000.50
9 Input the desired price for selection A1.	
10 Press D .	SELECT --
11 Repeat steps 7 through 10 for other selections.	
12 Press Service Mode Button 	(Sales Mode)



TEST VEND

STEP	DISPLAY
1 Press Service Mode Button 	DIAGNOSE
2 Press A .	MENU 2
3 Press A .	TEST
4 Press B .	TEST VEND
5 Press B .	SELECT --
6 Press A 1 for selection A1.	SELECT A1
7 Press B . The selection and price will display with the test vend. A triple beep indicates that the selection did not properly vend.	A1\$000.50 SELECT --
8 Repeat steps 6 through 7 for other selections.	
9 Press Service Mode Button 	(Sales Mode)



ACCOUNTING

STEP	DISPLAY
1 Press Service Mode Button 	DIAGNOSE
2 Press C .	MOTOR
3 Press C .	ACCOUNT
4 Press B .	HIST SALES
5 Press B .	HIST COUNT
6 Press C .	RES SALES
7 Press B . Total Sales since last reset.	\$000000.00
8 Press E .	RES SALES
9 Press C .	RES COUNT
10 Press B . Total Vends since last reset.	00000000
11 Press E .	RES COUNT
12 Press C .	RDR SALES
13 Press C .	2ND VEND
14 Press C .	SET RANGE
15 Press C .	RANGE CASH
16 Press C .	RANGEVENDS
17 Press C .	CLEAR
18 To clear all resettable values press B .	CLEARED
19 Press Service Mode Button 	(Sales Mode)

COIN PAY-OUT

STEP	DISPLAY
1 Press Service Mode Button 	DIAGNOSE
2 Press C .	MOTOR
3 Press C .	ACCOUNT
4 Press C .	COIN
5 Press B .	CPO
6 Press B .	DISPENSE
7 Press 1 .	DISPENSE
8 Press 2 .	DISPENSE
9 Press 3 .	DISPENSE
10 Press 4 .	DISPENSE
11 Press Service Mode Button 	(Sales Mode)

DISPLAY WORKING MOTORS

STEP	DISPLAY
1 Press Service Mode Button 	DIAGNOSE
2 Press C .	MOTOR
3 Press B .	MOTORS
4 Press B .	MOTORS 000
5 Press Service Mode Button 	(Sales Mode)

The diagram below (Figure 7) illustrates the overall view of the three main menus and the immediate sub-menus. Refer to the 120 Select Programming Manual (p/n 4212619) that shipped with your machine for additional programming instructions.

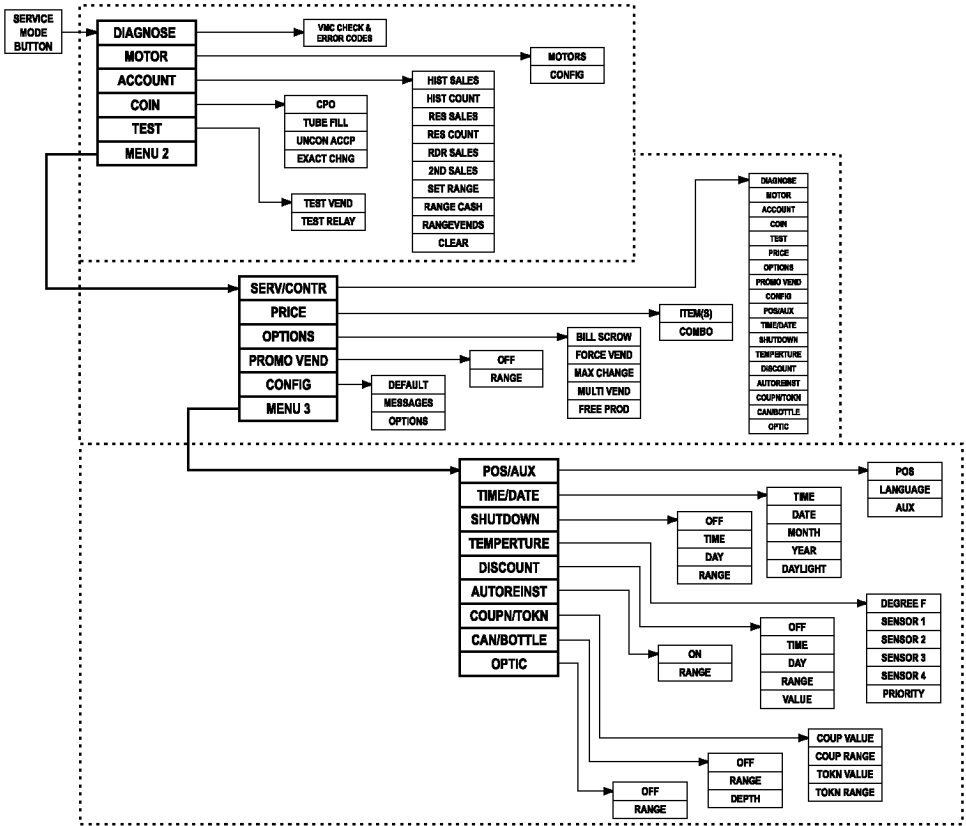

Figure 7. Menu Map

REFRIGERATION OPTION

OPERATION

To prevent damage to the refrigeration unit when it is turned off or the power interrupted, the refrigeration unit will not restart for at least three minutes regardless of the temperature.

When the temperature is above the cut-in temperature programmed, the unit is turned on. When the refrigeration unit reaches the cut-out temperature, it is turned off.

If the refrigeration unit runs for more than two hours without reaching the cut-out temperature, the unit is turned off for the programmed ten (10) minute defrost time. It will be turned on again automatically.

TROUBLESHOOTING

If the refrigeration unit is turned off or the power is interrupted, the refrigeration unit will not start for at least three (3) minutes regardless of the temperature. This is done to prevent damage to the refrigeration unit.

CAUTION:

Breaking the refrigerant joints or seals on the system voids the unit warranty. Failure to keep the condenser coil clean and free of dirt and dust and other similar debris voids the unit warranty.

If the refrigeration unit is turned off or the power is interrupted, the refrigeration unit will not start for at least three (3) minutes regardless of the temperature. This is done to prevent damage to the refrigeration unit.

Know and understand how the unit operates. Units may vary, but the operation is basically the same. Never guess at the problem. Find the symptom before attempting any repair.

NOTE:

Most refrigeration problems are electrical.

The sealed hermetic system should not be worked on outside the Factory Service Center. There are three (3) things that can go wrong with a sealed system and should be repaired only at the Factory Service Center. These are:

1. Low Charge - usually caused by leaks. Look for oil around seals and welds. Unit will not cool properly. The capillary tube is frosted before it enters the evaporator inlet tube.
2. Restriction in System (unit frosts, then melts) - not cooling properly.
3. Bad valves - unit does not cool properly - noisy compressor.

COMPRESSOR WILL NOT START

Compressor has no power:

- Machine not plugged in.
- Tripped breaker or blown fuse.
- Faulty wall outlet.
- Short or open in power cord.
- Temperature sensor circuit is open. Check with a Multi-Meter.
- Improper wiring.
- Low voltage: 5% below. Check the power source with a Multi-Meter.
- Overload defective: Trips too fast. Check overload with the Multi-Meter.
- Overload defective: Trips too fast. Check overload with the Multi-Meter.

- Start relay defective. Check start relay with the Multi-Meter.
- Compressor has open windings. Check compressor windings with a Multi-Meter.
- Defective refrigeration relay.
- Unplug power to the machine. Remove the relay plate. Use an insulated jumper wire to short the wires on relay terminals 2 and 4 or 6 and 8, then restore power to the machine. The compressor should start, indicating a problem in the control circuit.
- Check relay terminals 1 to 0 with a Multi-Meter. Should have have 24VDC applied to them.
- No DC voltage. Check control board output terminal for a loose connection.

COMPRESSOR TRIPS ON OVERLOAD

1. Improper voltage: 5-10% above, 5% below. Check power source with Multi-Meter.
2. Overload defective: Trips too fast. Check overload with Multi-Meter.
3. Relay defective: Won't open after starting. Check relay with Multi-Meter.
4. Compressor has shorted windings. Check compressor windings with Multi-Meter.

5. Short in other component: Isolate and eliminate each electrical component until short is found.
6. Compressor is too hot.
 - Dirty condenser.
 - Faulty condenser motor or blade.
 - Restricted airflow.

CAUTION:

Condenser must be kept clean of dirt and debris to allow for proper air circulation.

NOISY OR VIBRATING UNIT

1. Components rubbing or touching each other.
 - Check fan blades and motor.
 - Loose shrouds and harness.
 - Copper tubing.
 - Loose or unsecured parts.
 - Dirty condenser fan blades.

2. Worn or aged compressor grommet.
3. Compressor
 - Bad valves.
 - Slugging.
 - Bad windings. See schematic. Figure 8.
 - Low voltage.

UNIT SHORT CYCLES

1. Temperature sensor defective or not mounted in the return air duct.
2. Defective control board.
3. Temperature setting too warm. See Refrigeration Settings section of this manual.

UNIT OPERATES LONG OR CONTINUOUSLY

1. Temperature sensor defective or not mounted in the return air duct.
2. Refrigeration relay shorted.
3. Airflow restricted.
 - Faulty evaporator motor or blades causing coils to ice.
 - Loose connections on evaporator motor. One motor not running.
 - Airflow blocked by product in front of evaporator or air duct openings.
 - Exhaust area blocked. Machine too close to the wall.
4. Gasket leak around door.
5. Excessive load: After loading, unit runs longer to pull out excessive heat from product.
6. Shortage of refrigerant or restriction.
7. Bad controller.
8. Ambient air temperature and relative humidity exceed manufacturer's operational standards.

REFRIGERATED SPACE TOO COLD

1. Temperature sensor defective. Check with Multi-Meter.
2. Refrigeration control setting too cold. See Temperature Mode section of this manual.
3. Refrigeration relay bad. Check with Multi-Meter.
4. Faulty control board.

REFRIGERATED SPACE TOO WARM

1. Temperature sensor defective. Check with Multi-Meter.
2. Refrigeration control setting too warm. See Temperature Mode section on this manual.
3. Refrigeration relay bad.
4. Faulty control board.
5. Restricted evaporator space.
 - a. Evaporator motor blades faulty, causing the coils to ice over the evaporator.
- b. Condenser airflow restricted.
 - Plugged or dirty condenser.
 - Condenser motor blades bad.
 - Blade stuck.
- c. Condensing space restricted.
 - Unit placed too close to a wall.
- d. Compressor - bad valves.
 - Capillary tube will start frosting 8 to 10 inches (20-25 cm) past evaporator connection tube.
 - Check for oil around brazed connections.

TROUBLESHOOTING CIRCUITS WITH MULTI-METER

1. To check the power source, use the voltage section of the Multi-Meter. Should measure within 5-10% above, 5% below.
2. Check overload.

CAUTION

Power must be off and fan circuit open.

Use the resistance section of the Multi-Meter and check terminals 1 and 3 for continuity. If no continuity is measured (infinity), then the overload may be tripped. Wait 10 minutes and try again. If still no continuity, then overload is defective.
3. Check the relay. See Figure 8. Unscrew lead terminals and remove relay from compressor. Keep relay upright. Check terminals 1 and S, or L and S with the Multi-Meter. Replace relay if continuity exists.
4. Check Temperature sensor with a Multi-Meter.
5. Check compressor windings as shown in Figure 8.
6. Check winding resistance with a Multi-Meter. Use RX1 scale. If readings are not within 2 Ohms, the compressor is faulty.

WARNING:

Wiring diagrams must be followed as shown. Any mis-wiring can cause serious electrical hazard and potential damage or rupture component electrical parts.

Table 2. Winding Resistance

APPROXIMATE RESISTANCE ACROSS TERMINALS	
COMMON to START	12 Ohms
COMMON to RUN	2 Ohms
RUN to START	14 Ohms
COMMON to SHELL	No Continuity

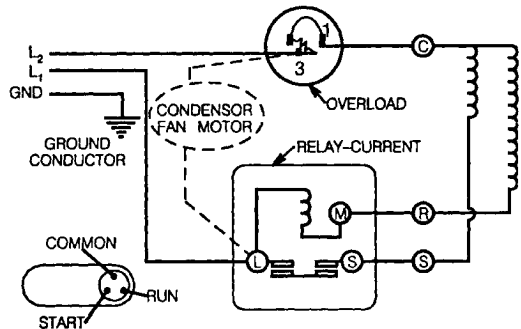

A10115

Figure 8. Compressor Schematic

PREVENTIVE MAINTENANCE

CAUTION:

Always disconnect power source BEFORE cleaning or servicing.

WARNING:

This machine must NOT be cleaned with a water jet.

ONCE A MONTH

CLEAN CABINET INTERIOR

Wash with a mild detergent and water, rinse and dry thoroughly. Odors may be eliminated by including baking soda or ammonia in the cleaning solution. Plastic parts may be cleaned with a quality plastic cleaner. Remove and clean Condensate Drain Hose to eliminate any deposits that may restrict condensate water flow. The vend mechanisms must be kept clean. Any build-up can cause the mechanisms to malfunction. **Do not get the cleaning solution on electrical components.** To insure proper vending keep delivery slide area free of dirt and sticky substances.

CLEAN CABINET EXTERIOR

Wash with a mild detergent and water, rinse and dry thoroughly. Clean occasionally with a quality car wax. Plastic exterior parts may be cleaned with a quality plastic cleaner.

EVERY 60 DAYS

CLEAN REFRIGERATION INTAKE SCREEN

Remove screen and clean dust and debris from screen using a soft bristle brush or a vacuum cleaner.

EVERY 60 DAYS

CLEAN CONDENSER COIL & REAR EXHAUST SCREEN

Remove the Cover Assembly and clean the condenser coil of the refrigeration unit using a soft bristle brush and/or vacuum cleaner. Pull the refrigeration unit and clean the rear exhaust screen of dirt and debris. Do not block the evaporator or any area of the airflow with product or supplies.

PARTS ORDERING PROCEDURE

When ordering parts, include the following:

1. The model and serial numbers of the machine for which the parts are needed.
2. Shipping address.
3. Address where the invoice should be sent.
4. The number of parts required.
5. Always refer to the pertinent parts and/or parts manual for the correct part number and description of a specific part.
When RIGHT or LEFT is used with the name of a part, it means the person is facing the machine with the door closed.
6. Any special shipping instructions.
7. Carrier desired: air or air special, truck, parcel post or rail.
8. Signature and date.

9. If a purchase order number is used, then be sure it is visible and legible.

Mail your order to:

VendNet™
165 North 10th Street
Waukee, IA 50263
USA

All orders are carefully packed and inspected prior to shipment. Damage incurred during shipment should be reported at once and a claim filed with the terminating carrier.

If you do not have the right parts manual, contact VendNet™.

If you have any questions, check out our website www.vendnetusa.com or call VendNet™. Ask for the Parts Department. We will be happy to assist you. Email: vendnet@vendnetusa.com

BEFORE CALLING FOR SERVICE

Please check the following:

- Does your machine have at least 6 inches (15.2 cm) of clear air space behind it?
- If the power is turned on at the fuse box, is the machine the only thing that does not work?
- Is the machine plugged directly into the outlet?

WARNING:

DO NOT USE EXTENSION CORDS. Extension cords can cause problems.

- Is the evaporator coil free of dust and dirt?
- Is the condenser coil free of dust and dirt?
- Is the compressor free of dust? A blanket of dust can prevent the compressor from cooling in between workouts.
- Is the circuit breaker at the fuse box reset?
- Are evaporator fans running? To check if fans are running take a small piece of paper in front of the evaporator coil and see if the evaporator fans will blow the paper away.
- Is the condenser fan running? Fold a sheet of 8-1/2" x 11" paper in half. Place the paper in front of the condenser coils and see if it draws paper to it.
- Is the shelf in front of the evaporator coil clear? No tools, product, or other air restricting items.
- Is the cold control set as specified?

Setting the temperature colder does not accelerate cooling of product but may and may cause the product to freeze.

The contents of this publication are presented for informational purposes only, and while every effort has been made to ensure their accuracy, they are not to be construed as warranties or guarantees, express or implied, regarding the products or services described herein or their use or applicability. We reserve the right to modify or improve the designs or specifications of such products at any time without notice.

Vendnet
A WITTEN GROUP COMPANY

VendNet™
 165 North 10th Street
 Waukee, Iowa 50263
 United States of America



	USA & Canada	International
Service	(800) 833-4411	(515) 274-3641
Parts	(888) 259-9965	
Email	vendnet@vendnetusa.com	
Web Site	www.vendnetusa.com	

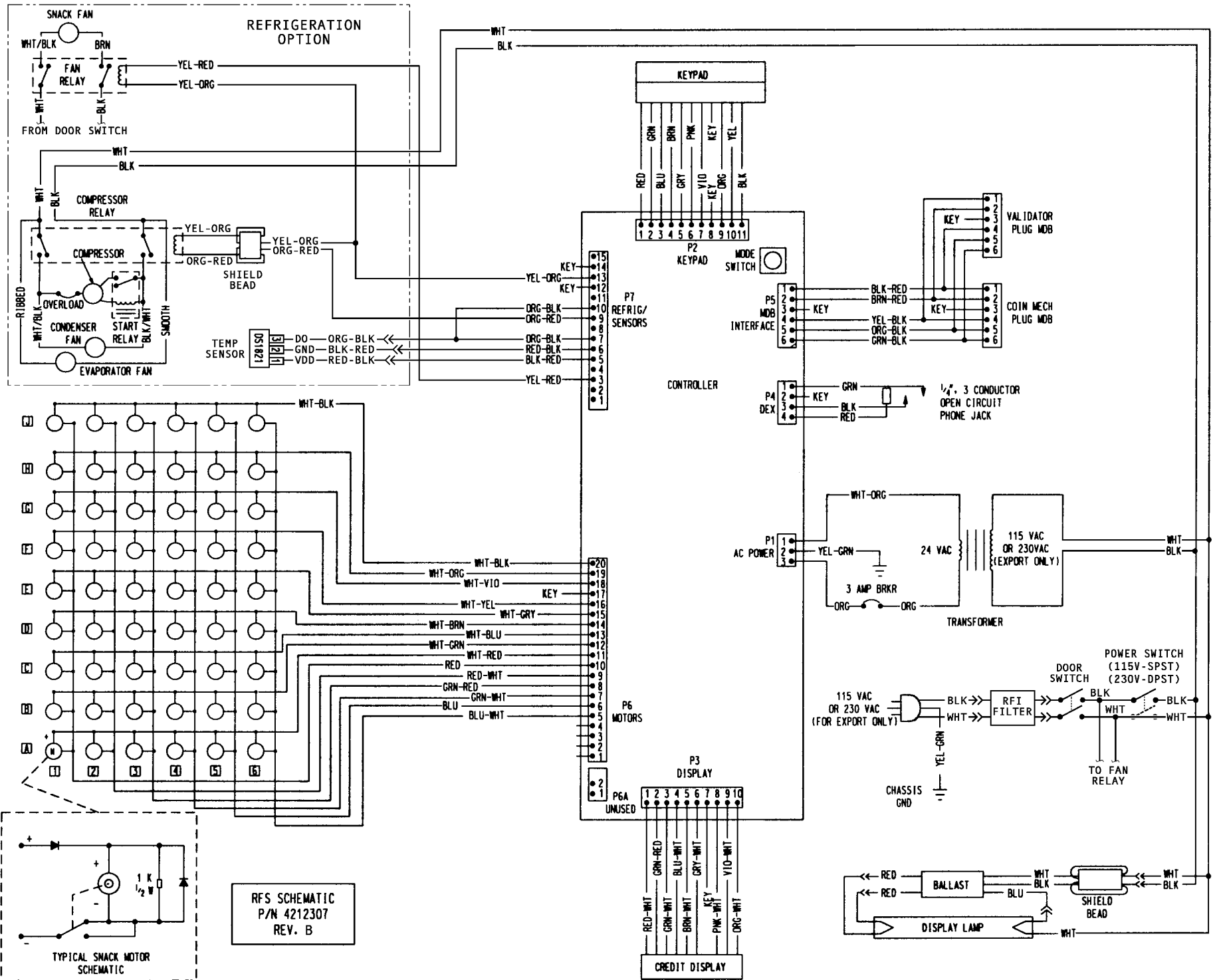

Figure 9. Schematic Diagram