

AMBIENT SNACK VENDOR (WS/HR SERIES)

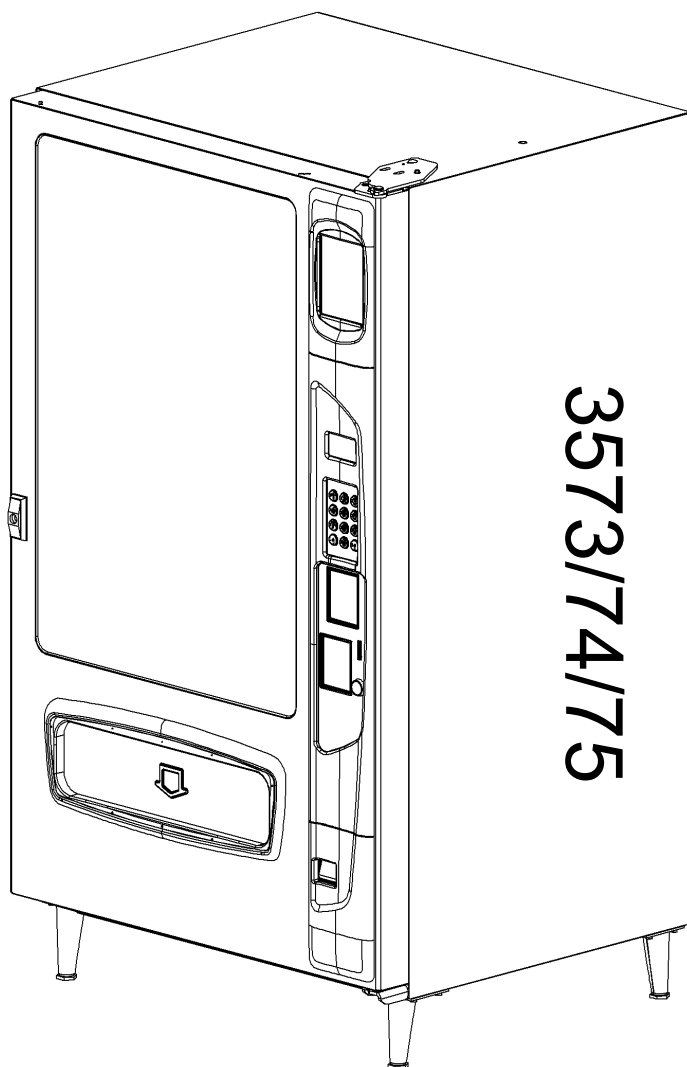

3573/74/75

MODELS:

3573 – WS/HR 3000

3574 – WS/HR 4000

3575 – WS/HR 5000

SERVICE MANUAL

TABLE OF CONTENTS

SPECIFICATIONS.....	2
UNPACKING.....	2
INSTALLATION	3
GROUNDING & ELECTRICAL	3
Door Stop Bolt Installation.....	3
LOADING PRODUCTS	3
AUGER AND TRAY ADJUSTMENT	3
Tray Spacing	3
3 Wide and 4 wide tray spacing adjustments	4
SWITCHING FROM CANDY TO SNACK	4
SWITCHING FROM SNACK TO CANDY	5
Gum and Mint Tray.....	5
Product Pushers.....	5
AUGER TIMING.....	5
TRAY CONFIGURATION.....	6
Snack/Candy/Food Tray	6
TABLE 1: AVAILABLE AUGERS	6
CONTROLLER FUNCTIONS	7
Vend Cycle	7
Credit and Counters	7
SERVICE MODE.....	7
Service Mode Button	7
KEYPAD	8
DISPLAY.....	8
Programming	8
SERVICE MODE PROGRAMMING INSTRUCTIONS	8
1 TUBE FILL/ DISPENSE COINS	8
2 MOTOR COUNT	8
3 OPTIONS.....	8
3.1 FORCE VEND.....	9
3.2 BILL ESCROW.....	9
3.3 MULTI VEND.....	9
3.4 FREE VEND.....	9
3.5 FAST CHANGE.....	10
3.6 OPTICAl Vend	10
3.7 POINT OF SALE MESSAGE (pos)	11
3.8 SETPOINT (not applicable)	11
3.9 KEYPAD BACKLIGHT	11
3.0 DROP SENSOR SENSITIVITY (Not Applicable)	11
4 CONFIGURATION.....	12
4.1 ALL (not applicable)	12
4.2 ROW (not applicable).....	12
4.3 ITEM (not applicable)	12
4.4 LANGUAGE	12
4.5 AUTO_REINSTATE	12
4.6 SPACE TO SALES (STS)	13
4.7 CUSTOM STS.....	13
4.8 TIME/DATE	14
4.9 HEALTH SAFETY (not Applicable)	15

4.0 ADVANCED CONFIGURATION	15
5 PRICING	16
5.1 ALL	16
5.2 ROW.....	16
5.3 item.....	16
5.4 coupon.....	16
5.5 TOKEN	18
5.7 COMBO	19
6 ACCOUNTING.....	20
6.1 ACCOUNTING "ALL"	20
6.2 ACCOUNTING BY ROW	20
6.3 ACCOUNTING BY ITEM	21
7 ADVANCED OPTIONS.....	21
7.1 DISCOUNT	21
7.2 PROMO VEND.....	25
7.3 FREE VEND RATE	26
7.4 EXACT CHANGE.....	26
7.5 UNCONDITIONAL ACCEPTANCE	26
7.6 MAX CHANGE	26
7.7 PROGRAMMABLE POS MESSAGE	27
7.8 SHUTDOWN	28
8 ENERGY SAVINGS (NOT APPLICABLE).....	32
9 TEST	32
TEST ALL MOTORS	32
0 DIAGNOSTIC.....	32
0.2 TEST RELAY (not Applicable).....	33
0.3 LOG.....	33
0.4 COIN REJECT RATE	33
0.5 BILL REJECT RATE.....	33
0.6 IVEND ALIGNED	33
CUSTOMER LEAD THROUGH MESSAGES	33
PREVENTATIVE MAINTENANCE 35	
Clean cabinet interior	35
Clean Cabinet Exterior	35
PARTS ORDERING PROCEDURE 35	
BEFORE CALLING FOR SERVICE36	
ELECTRICAL SCHEMATIC.....	37
NOTES:.....	2

The Model and Serial numbers are needed to obtain quick service and parts information for your machine. The numbers are given on the identification plate located on the back side of the cabinet of the machine.

MODEL NUMBER: _____
 SERIAL NUMBER: _____

Introduction

This manual contains instructions, service and installation guidelines for the **Glass Front Snack (WS/HR Series)** product line.

The WS Series models are equipped with an electronic control system. All vending functions, pricing, and features are programmed through the controller. Changes can be made without any additional accessories or remote parts.

Selections can be priced individually from \$.05 to \$999.99 in five cent increments (US currency). When adapted to accept international or foreign currency, the maximum vend price will be 255 times the smallest denomination of coin being accepted.

Cash Accountability records Total Cash transactions and Total Vend cycles performed by the vendor. Information for individual selections, complete rows or total machine can be compiled and used for inventory and ordering records.

Electrical malfunctions are recorded and displayed when the machine is placed in Service Mode. Non-functioning motors or selections are indicated. Each selection has an individual motor. Functional selections will continue to operate if other motors become non-functional.

The vending sequence is "first-in, first-out" for each selection, eliminating the need for stock rotation to assure product freshness.

Options: The iVend™ Optical Sensing option assures that the customer receives the purchased product or receives a refund.

Read this manual thoroughly. Become familiar with the machine's components and features. The initial setup of a vending machine is a very important step toward insuring that the equipment operates trouble-free. Carefully follow the instructions for the initial installation of the machine to avoid service problems and minimize setup time.

Access to the service area of this machine should be permitted only to individuals having knowledge and practical experience in machine setup and loading, especially in the areas of safety and hygiene.

If you have questions concerning the information in the manual, replacement parts, or the operation of the vendor, note your machine's Model # and SN # before contacting your local distributor or:

VendNet
165 North 10th Street
Waukee, IA 50263
Phone: (800) 833-4411
Parts Fax: (515) 271-8555
Sales Fax: (515) 271-8555
E-mail: vendnet@vendnetusa.com
www.VendNetUSA.com

SPECIFICATIONS

DIMENSIONS

Model	3573	3574	3575
Type	3-Wide	4-Wide	5-Wide
Width	29.3 inches	35.2 inches	41.1 inches
Weight	445 lbs.	519 lbs.	626 lbs.
Depth	34.75 inches		
Height	72 inches		

FACTORY TRAY CONFIGURATION

Type	3-Wide	4-Wide	5-Wide
Trays	6	6	6
Selections	24 (expandable to 36)	36 (expandable to 48)	40 (expandable to 60)
Gum & Mint (optional)	4 selections		

ELECTRICAL

Voltage	115 VAC	230 VAC
Cycle	60 Hz	50 Hz
Amperage	1.2	0.6
Transformer	115 VAC – 24 VAC	25 VAC

COINAGE

MDB Version	Any MDB validator, coin mechanism or card reader
International	
Domestic	

VENDOR OPERATION

Location	Suitable for indoor use only. This appliance is not suitable for installation in an area where a water jet could be used.
Sound Level	Produces less than 70 dBA during normal operation.
Recommended Operating Temperature	Between 32° and 100° F° (0° and 37.8° Celsius).

UNPACKING

This machine was thoroughly inspected before leaving the factory and the delivering carrier has accepted responsibility for this vendor. Note any damage or irregularities at the time of delivery and report them to the carrier. Request a written inspection report from the claims inspector to file any claim for damage. File the claim with the carrier (not the manufacturer) within 15 days after receipt of the machine.

Carefully remove the outside packing material being careful not to damage the machine's finish or exterior. Inspect the machine for concealed shipping damage. Report any damage hidden by the shipping material directly to the delivering carrier on a Hidden Damage Report.

NOTE: if the power supply cord is damaged, it must be replaced by the manufacturer, its service agent, or similarly qualified individual in order to avoid hazard.

Remove the knock-away support by placing a 2X6 under the vendor. Insert a large screwdriver or prying tool into the groove and split it in two. Turn the leveling screws as far as possible. See Figure 1.

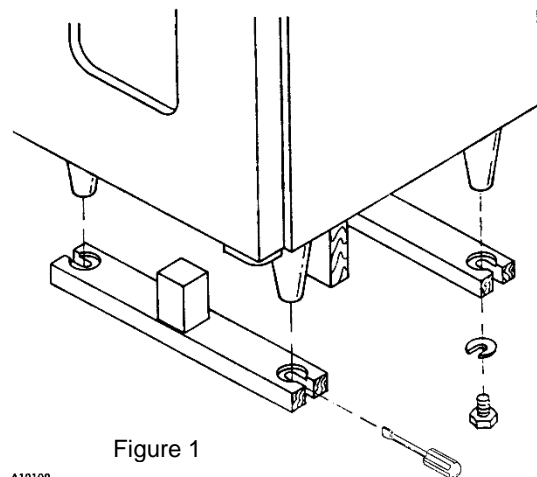

Figure 1

A10109

INSTALLATION

Position the vendor in its place of operation on a flat, smooth surface in such a way that the vendor's power cord easily reaches the power outlet or receptacle (DO NOT USE AN EXTENSION CORD), and check that the door will open fully without interference.

Leave at least six inches of space between the back of the machine and any wall or obstruction for proper air circulation.

Level the vendor, making sure all levelers are touching the floor. The vendor must be level for proper operation and coin acceptance through the coin mechanism.

Retrieve the vendor keys from the coin return cup. Open outer door and remove all internal packing material.

Consult local, state, and federal codes and regulations before installing the vendor.

GROUNDING & ELECTRICAL

Refer to the Safety Manual and Installation Guidelines manual (P/N 4206816) found in the service package shipped with your machine.

Before connecting the vendor, the integrity of the main electrical supply must be checked for correct polarity, presence of ground (earth) and correct voltage. These checks should be repeated at six-month intervals with the routine safety electrical testing of the vendor itself.

If the receptacle is not properly grounded or polarized, contact a licensed electrician to correctly polarize and/or ground the receptacle to ensure safe operation.

A noise suppressor has been installed in this machine to compensate for any mains signal noise that could interfere with the normal operation of the controller.

For proper operation of any equipment utilizing electronically controlled components, the equipment should be placed on an isolated, or dedicated, noise-free circuit properly polarized and grounded.

Refer to Electrical Specifications in this manual to determine circuit amperage and protection.

DOOR STOP BOLT INSTALLATION

The service package included with your machine includes a Door Stop Bolt. This Bolt can be installed in place of one of the top hinge retaining screws as shown. The Bolt provides a door stop to prevent the machine door from opening fully into obstacles or machines to the right of the machine.

LOADING PRODUCTS

To load products, lift the tray slightly and pull forward until the tray stops. The uppermost trays tilt for easier loading.

Load product from front to back making sure all items fit freely between the augers. Do not attempt to force oversize items or packages into the spaces. Do not skip a space. Place the product on the bottom of the compartment on the product augers with the labels facing the front of the machine for easy identification by the customer. See Figure 2.

To vend properly the item being vended must be wider and taller than the diameter of the auger being used. Undersize items could cause vend problems. If the product does not fit the auger properly, use a different pitched auger. See Tables 1 and 1b for augers available from your distributor or service entity.

AUGER AND TRAY ADJUSTMENT

By retiming the augers and/or adding product pushers, difficult-to-vend items can be dispensed more dependably. By altering tray spacing, larger items can be vended. By changing the tray configuration, different product mixes can be accommodated.

TRAY SPACING

Trays can be adjusted up or down in one-inch increments to provide additional headroom for vending taller products. When increasing the height in one area, the same amount of space will be lost by the tray above or below.

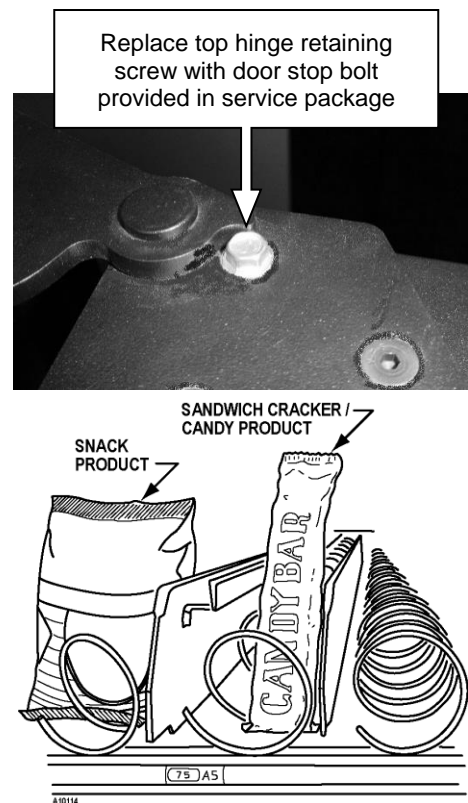

Figure 2

3 WIDE AND 4 WIDE TRAY SPACING ADJUSTMENTS

1. Pull out the tray to be adjusted until it stops.
2. Disconnect the tray harness from its snap-open harness clamp on the right sidewall. See Figure 3.
3. Disconnect the tray plug from its receptacle on the right sidewall.
4. Lift up on the front of the tray and pull slightly forward approximately ½ inch (1.5 cm) to clear tray stop.
5. Lift up on the rear of the tray and remove it from the vendor.
6. Disengage both left and right tray rails from their corresponding slots on the left and right sidewalls by pulling inward on the bottom front of each rail and lifting its flange out of the slot.
7. Pull each rail forward to disengage its rear tabs from the hole in the rear wall.
8. Relocate both left and right rails by reversing steps 6 and 7.
9. Replace the tray by placing its rear rollers on the left and right rails and lift up on the front of the tray as it is pressed back.
10. Install the tray plug into its receptacle on the right sidewall.
11. Reengage the tray harness into its harness clamp and snap closed.
12. Test vend the tray in its new position to assure that the tray plug is properly seated.

5 Wide tray spacing adjustments

1. Pull out the tray to be adjusted until it stops.
2. Disconnect the tray harness from its snap-open harness clamp on the right sidewall. See Figure 3.
3. Disconnect the tray plug from its receptacle on the right sidewall.
4. Lift up on the front of the tray and pull slightly forward approximately ½ inch (1.5 cm) to clear tray stop.
5. Lift up on the rear of the tray and remove it from the vendor.
6. Locate the release levers on the left and right tray rails. (see figure 4) Swing the release levers all the way up to unlatch.
7. Lift up on the rear of the tray and remove it from the vendor.
8. Relocate both left and right rails.
 - a. Remove tray mounting screws
 - b. Pull each rail forward to disengage its rear tab from the hole in the rear wall. (see figure 5)
9. Relocate both left and right rails by reversing step 8. Assure that rails are level from front to back and right to left.
10. Replace the tray by placing its rear rollers on the left and right rails and lift up on the front of the tray as it is pressed back, taking care to keep the tray level as it is pushed in.
11. Swing the tray release levers all the way down.
12. Install the tray plug into its receptacle on the right sidewall.
13. Reengage the tray harness into its harness clamp and snap closed.
14. Test vend the tray in its new position to assure that the tray plug is properly seated.

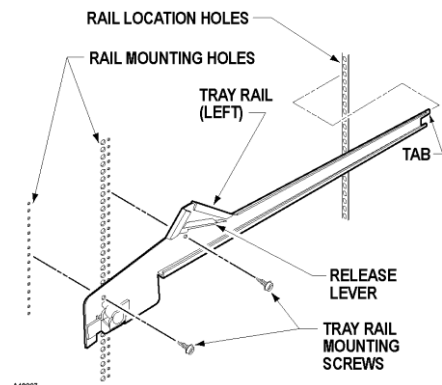

Figure 4: Tray rails

SWITCHING FROM CANDY TO SNACK

NOTE: THIS OPTION REQUIRES THE PURCHASE OF A CONVERSION KIT

CONVERSION STEPS:

1. Unplug and remove the tray assembly from the vendor. Place the tray harness in the tray before removal.
2. Remove the motor cover by pulling up on the front edge of the cover to clear the stop and then pull forward on the cover.
3. Remove the existing tray divider and discard.
4. Remove the existing auger assembly and discard.
5. Remove the existing "even" numbered motor. This motor will not be needed.
6. Tape or secure the terminals removed from the motor and place aside.
7. Move the "odd" numbered motor to the center slot of the compartment.
8. Install the auger retainer furnished in the conversion kit.
9. Install the auger assembly furnished in the conversion kit, making sure that the motor coupling properly engages the motor and is securely snapped over the vertical rail or retaining ring on the tray.
10. Re-assemble the motor cover removed in step 2.
11. Replace the tray assembly into the vendor, making sure that the tray is properly located and latched; connect the tray harness.
12. Set the selection vend price and adjust the price scroll to reflect same. Large item selections will be "odd" numbers. For example, selections 23 and 24 are converted to a single selection, 23.
13. Test vend the converted selection for proper operation and price setting.

SWITCHING FROM SNACK TO CANDY

NOTE: THIS OPTION REQUIRES THE PURCHASE OF A CONVERSION KIT

CONVERSION STEPS:

1. Unplug and remove the tray assembly from the vendor. Place the tray harness in the tray before removal.
2. Remove the motor cover by pulling up on the front edge of the cover to clear the stop and then pull forward on the cover.
3. Remove the existing auger assembly and discard.
4. Remove the auger retainer and discard.
5. Move the motor from the center slot to the left slot in the compartment.
6. Add the new motor (furnished in the conversion kit) in the right-hand slot of the compartment.
7. Properly wire the motor and switch. Refer to the Schematic diagram for proper wire colors and location.
8. Install the divider furnished in the conversion kit.
9. Install the auger assemblies furnished in the conversion kit, making sure that the motor couplings properly engage the motors and are securely snapped over the vertical rail or retaining ring on the tray.
10. Re-assemble the motor cover removed in step 2.
11. Replace the tray assembly into the vendor, making sure that the tray is properly located and latched; connect the tray harness.
12. Set the selection vend price and adjust the price scroll to reflect same.
13. Test vend the converted selections for proper operation and price settings.

GUM AND MINT TRAY



Loading:

Load G&M spirals from front to back as shown being sure to not skip spaces. Be sure to push the tray back fully after loading.

Selection Divider Installation:

For products that are narrower than the provided compartment size (i.e. 5 stick gum or Breath savers mints) dividers may be required. The dividers are installed on

either side of the compartment to center the products for proper vending. Each divider requires three screws for installation as shown.

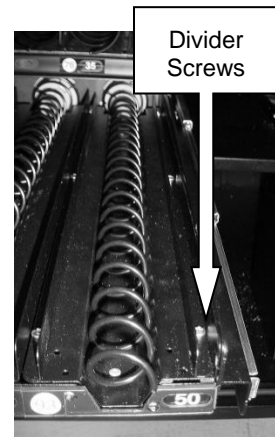

Spiral Adjustment:

The G&M spirals are held to the motors with adjustable splined couplings. The couplings can be adjusted every 20 degrees. This adjustment may be required to properly vend different products. The coupling is pulled forward and out of the motor, spiral timing is adjusted, and then reinstalled. Be sure to reinstall the black rubber cap on the back shaft of the coupling to fully retain the spiral. Test vend and adjust the timing as necessary.

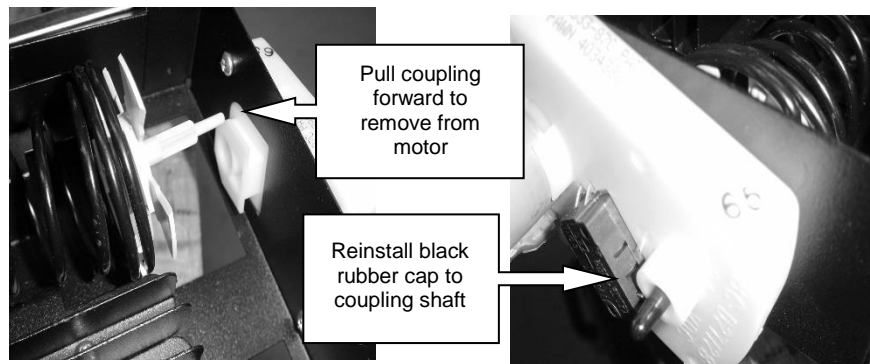

PRODUCT PUSHERS

Order product pusher P/N 4226049.12. Snaps on to end of auger. See Figure 3.

AUGER TIMING.

The shape, size and thickness of product affects how well it falls off the tray. Most items can be vended successfully when the auger end is positioned at 6 o'clock. If vending problems occur with auger ends at the standard 6 o'clock position, adjust the drop-off either with product pushers or by retiming the auger.

Auger Retiming

Each auger can be rotated in 20° (degree) increments for a different drop-off point. Most items can be vended successfully when the auger end is positioned at the factory set default position of 6 o'clock.

To change the auger position:

1. Remove the motor cover. (see figure)
2. Raise the motor slightly and pull forward on the auger until it separates from the motor.
3. Rotate the auger to the desired position and reinsert the auger coupling into the motor.
4. Make sure the auger coupling is seated over the vertical rail or retaining rib on the tray.
5. Replace the motor cover, making sure it is securely tightened.

TRAY CONFIGURATION

SNACK/CANDY/FOOD TRAY

Each auger can be rotated in 20° (degree) increments for a different product vend drop-off point. Most items can be vended successfully when the auger end is positioned at 6 o'clock.

The general rule is - **the narrower the product, then the higher the timing.**

- Thick Products - 4-6 o'clock
- Most products – 6 o'clock
- Thin Products - 6-8 o'clock

TO CHANGE AUGER TIMING

1. Remove the motor cover. See Figure 6f.
2. Raise the motor slightly and pull forward on the auger until it separates from the motor.
3. Rotate the auger to the desired position and re-insert the hub (auger coupling) into the motor. The hub (auger coupling) must be seated over the vertical rail or retaining rib on the tray.
4. Replace the motor cover making sure it is securely tightened.
5. Test vend to make sure product vends correctly.

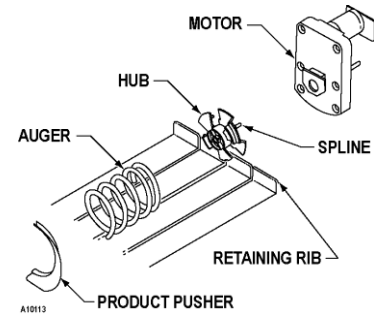

Figure 6f. Motor & Auger (Standard Tray)

TABLE 1: AVAILABLE AUGERS

WS Series					
TYPE	PRODUCT			STANDARD PART NUMBER	DUAL AUGER PART NUMBER
	WIDTH	THICK	QTY		
CANDY	2.75	3.25	5	4200272.145309	4205532.145309
		3.16	6	4200272.106309	4205532.106309
		2.37	8	4200272.142309	4205532.142309
		2.10	9	4200272.105309	4205532.105309
		1.89	10	4200272.131309	4205532.131309
		1.72	11	4200272.132309	4205532.132309
		1.55	12	4200272.104309	4205532.104309
		1.22	15	4200272.100309	4205532.100309
		1.00	18	4200272.101309	4205532.101309
		0.71	24	4200272.102309	4205532.102309
		0.51	30	4200272.103309	4205532.103309
SNACK	5.50	3.25	5	4200272.139309	
		3.16	6	4200272.138309	
		2.71	7	4200272.110309	
		2.37	8	4200272.111309	
		1.89	10	4200272.107309	
		1.55	12	4200272.108309	
		1.22	15	4200272.109309	
		1.00	18	4200272.134309	
		0.51	30	4200272.133309	

CONTROLLER FUNCTIONS

This vending machine is equipped with a GVC2 controller.

Sales Mode

The machine automatically defaults to **Sales Mode** after it is turned on. The vendor accepts deposits, pays out change and dispenses product to the customer.

Display Credit

If a selection is made and credit has not been established, the price for that selection is displayed briefly. When money or credit is accepted, then the amount of credit is displayed. If the coin levels in the coin mechanism payout tubes are below the low-level sensors, the indicator light "**USE EXACT CHANGE**" will light up.

Make Selection

If a selection is made and the accumulated credit is greater than, or equal to, the price of the selection, then a vend attempt will take place. If credit is less than the selection price, the price is displayed and will flash.

VEND CYCLE

1. The normal home-switch-vend cycle will be used. Both the vend motor and a vend timer are started.
2. The selection motor rotates to the home-switch position.
3. If there is a home-switch signal, then the vend is considered successful.
4. If there is no home-switch signal, and the vend timer has expired, then the vend failed. The vend motor is shut down and "MAKE ANOTHER SELECTION" indicator light is turned on. The customer can press selection buttons to make another selection or they can press the coin return button.

CREDIT AND COUNTERS

- After a successful vend, the amount of remaining credit is displayed until all coinage is paid back.
- The total non-resettable vend count is incremented by one and the total non-resettable cash value is incremented by the price of the vended selection.
- The counter rollovers occur at 999,999 and \$999,999.99 respectively.
- The resettable vend count is incremented by one.
- The resettable total cash value is incremented by the price of the vended selection.
- If never reset, the counter rollovers occur at 999,999 and \$999,999.99 respectively.
- Test vends are not included in the counter totals.

SERVICE MODE

The Service Mode is used to access the programming features of the controller: Set Price, Test Vend, Retrieve Accounting Information, or Set Custom Program Settings. If credit exists when entering the Service Mode, it will be restored when the machine is returned to Sales Mode.

SERVICE MODE BUTTON

The Service Mode Button is located near the top right corner of the controller board cover. Press the button to access the Service Mode programming features. Press the button again to exit and return to Sales Mode. If no key is pressed within 60 seconds while in Service Mode, the controller automatically exits to the Sales Mode.

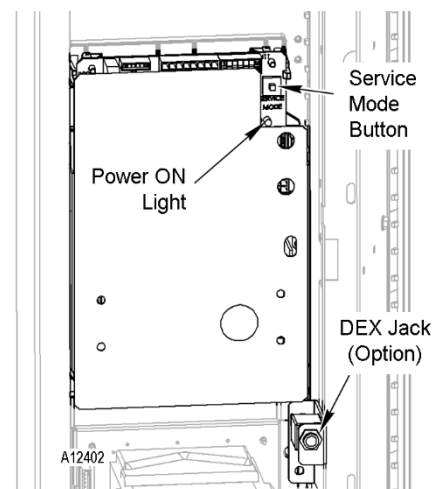

KEYPAD

Use the buttons on the keypad as directed in the step-by-step instructions in this manual in programming the vendor.

DISPLAY

Check the display after pressing the **Service Mode Button** and/or **Keypad Buttons** to make sure that the program is responding correctly.

Buttons 0-9 are used to move between the various modes, menus and sub-menus; while the **#** button is used to enter a menu, confirm or save a setting.

See Figure 3

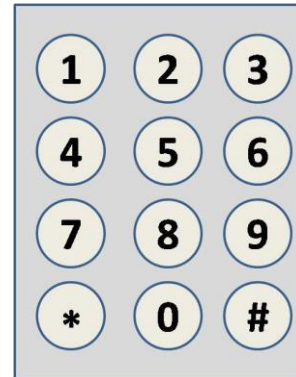

FIGURE 3: KEYPAD

PROGRAMMING

Refer to the basic programming steps in this manual or on the control cover label. Press the Service Mode Button; check the display for instructions or choices while using the keypad.

SERVICE MODE PROGRAMMING INSTRUCTIONS

1 TUBE FILL/ DISPENSE COINS

TUBE FILL

Tube Fill counts coins as they are deposited and Shows the dollar amount.

	STEP	DISPLAY
1.	Press Service Mode Button	Motor Count 60
2.	Press 1 and begin depositing coins	At least 15 of each denomination
3.	Press * 2 times to exit	(Sales Mode)

TUBE DISPENSE

Tube Dispense Pays out coins from the coin mech coin tubes. This mode will also display the current quantity of coins in the coin mech tubes.

1.	Press 1 to dispense dollar coin	\$1.00/coins
2.	Press 2 to dispense quarters	0.25/coins
3.	Press 3 to dispense dimes	0.10/coins
4.	Press 4 to dispense nickels	0.05/coins
5.	Press * 2 times to exit	(Sales Mode)

****Note:** For dispensing more than a 4 denomination coin mech. use keys greater in the same sequence as shown above.**

2 MOTOR COUNT

Displays the total count of working motors.

	STEP	DISPLAY
1.	Press Service Mode Button	Motors (- -)
2.	Press 2 then wait.	Motors (- -)
3.	Press * to exit.	(Sales Mode)

3 OPTIONS

This menu allows access to the following features:

- Force Vend
- Bill Escrow
- Multi Vend
- Free Vend
- Fast Change
- Optics
- Point Of Sale Message
- Temperature
- Keypad Backlight
- Drop Sensor Sensitivity

3.1 FORCE VEND

This option will force the customer to complete a purchase once they have deposited money of any form.

	STEP	DISPLAY
1.	Press Service Mode Button 	Motors (- -)
2.	Press 3	Options
3.	Press 1 to view current setting	Force Vend OFF
4.	Press 1 to toggle ON or OFF	Force Vend ON
5.	Press # to save setting	Force Vend ON
6.	Press * 3 times to exit	(Sales Mode)

Note: If a vend is attempted on a configured selection and the motor fails during this vend, the customer will be allowed to escrow the credit, regardless of the force vend status.

3.2 BILL ESCROW

This option allows the last bill accepted to be returned, provided the bill acceptor is capable of such a feature.

	STEP	DISPLAY
1.	Press Service Mode Button 	Motors (- -)
2.	Press 3	Options
3.	Press 2	Bill Escrow ON
4.	Press 2 to toggle ON or OFF	Bill Escrow OFF
5.	Press # to save setting	Bill Escrow OFF
6.	Press * 3 times to exit.	(Sales Mode)

3.3 MULTI VEND

This option allows the customer to purchase more than one product if enough credit has been deposited.

When this option is active, any credit remaining after a vend attempt is **not** automatically returned. At this point, the customer has the option of:

	STEP	DISPLAY
1.	Press Service Mode Button 	Motors (- -)
2.	Press 3	Options
3.	Press 3	Multivend OFF
4.	Press 3 to toggle ON or OFF	Multivend ON
5.	Press # to save setting.	Multivend ON
6.	Press * 3 times to exit.	(Sales Mode)

- Making another selection if there's enough credit.
- Depositing more money (cash credit from a changer or bill acceptor); or
- Press coin return to receive remaining credit.

Note: After 5 minutes any credit that is left on the display will disappear.

Note: For card reader sessions, the **Multi-vend** feature will function only if the card reader supports multiple vend capability.

3.4 FREE VEND

This option allows you to set the **whole machine** to Free Vend.

WITH **FREE VEND** ENABLED, EVERY PRODUCT WILL BE VENDED AT NO COST, NO MONEY IS ACCEPTED BY THE MACHINE, THE MESSAGE "**FREE ON US**" WILL BE ON THE DISPLAY.

	STEP	DISPLAY
1.	Press Service Mode Button 	Motors (- -)
2.	Press 3	Options
3.	Press 4	Free Vend OFF
4.	Press 4 to toggle ON or OFF	Free Vend ON
5.	Press # to save setting.	Free Vend ON
6.	Press * 3 times to exit	(Sales Mode)

3.5 FAST CHANGE

Allows the vending machine to give change immediately after the customer makes a selection. If **Fast Change** is ON, it will override the Multi Vend feature.

	STEP	DISPLAY
1.	Press Service Mode Button 	Motors (- -)
2.	Press 3	Options
3.	Press 5	Fast Change ON
4.	Press 5 to toggle ON or OFF	Fast Change OFF
5.	Press # to save setting.	Fast Change OFF
6.	Press * 3 times to exit	(Sales Mode)

NOTE: If "OPTICS" is turned ON the amount of the product will display until product drops.

3.6 OPTICAL VEND

Optical Sensor Control Options - This submenu provides the operator with options for designating product items or rows that will be monitored for product delivery by an optical sensor. Default is ALL selections "ON" unless changed.

3.6.1 Optics All

	STEP	DISPLAY
1.	Press Service Mode Button 	Motors (- -)
2.	Press 3	Options
3.	Press 6	Optical Vend
4.	Press 3 to toggle ALL ON/OFF	ALL ON/OFF
5.	Press # to save	ALL OFF
6.	Press * 3 times to exit	Sales Mode

3.6.2 Optics by Row

	STEP	DISPLAY
1.	Press Service Mode Button 	Motors (- -)
2.	Press 3	Options
3.	Press 6	Optical Vend
4.	Press 2 to enter Row	Row 01 ON
5.	Press 1 to toggle ON/OFF	Row 01 OFF
6.	Press # to save	Row 01 OFF
7.	Press * to enter another Row or 3 times to exit	Sales Mode

3.6.3 Optics by Item

	STEP	DISPLAY
1.	Press Service Mode Button 	Motors (- -)
2.	Press 3	Options
3.	Press 6	Optical Vend
4.	Press 1 to enter Item	Item 010 ON
5.	Press 1 to toggle ON/OFF	Item 010 OFF
6.	Press # to save	Item 010 OFF
7.	Press * to enter another item or 3 times to exit	Sales Mode

The controller must be in **Sales Mode**. If the accumulated credit is equal to or larger than the selection price when a selection is entered, the motor corresponding to that selection will be turned on. Selections that are designated as **Optical** will have an associated vend operation that differs from the normal vend operation.

For 5 milliseconds at the start of a vend, the **iVend™** optical sensor will be checked for blockage.

If blocked - the normal home-switch-vend cycle will be used and the optical sensors will be ignored. Both the vend motor and a 10 second vend timeout timer will be started.

- The selection motor rotates to the home-switch position.
- If there is a home-switch signal, the vend is considered successful.
- If after 10 seconds there is no home-switch signal, the vend failed. The vend motor is shut down and **MAKE ANOTHER SELECTION** is displayed. The customer can then press selection buttons to activate this or another motor, or press the Coin Return.

NOTE: Force Vend is overridden under this vend cycle.

If not blocked - the iVend™ Sensor System is used. The vend motor and a 10 second vend timeout timer are started.

- The selection motor rotates to the home-switch position.
- If a product is detected during this time period, the vend is considered successful.
- If after reaching the home-switch position, a product has not been detected, the vend motor will pause for 1 second while the controller continues to monitor the optical sensor for product delivery.
- If a product is detected during this pause, the vend is considered successful.
- If a product is not detected, the controller initiates a second vend cycle and a 9 second timer while continuing to monitor the optical sensor.
 - If a product is detected during this second cycle, the motor will be stopped immediately. The vend is considered successful. The 2nd Vend Count is increased by 1.
 - If a product is not detected before the motor reaches the home-switch position, or if a 9 second timer runs out, the vend has failed or the selection is sold out. Such a state will trigger the display message, **MAKE ANOTHER SELECTION**, and the amount of credit is displayed. The customer can press selection buttons to activate this or another motor or press the Coin Return.

3.7 POINT OF SALE MESSAGE (POS)

Turn OFF (or ON) the default scrolling display message.

NOTE: This does not affect the programmed POS message

	STEP	DISPLAY
1.	Press Service Mode Button 	Motors (- -)
2.	Press 3	Options
3.	Press 7	POS Message ON
4.	Press 7 to toggle ON or OFF.	POS Message OFF
5.	Press # to save setting.	POS Message OFF
6.	Press * 3 times to exit.	(Sales Mode)

3.8 SETPOINT (NOT APPLICABLE)

3.9 KEYPAD BACKLIGHT

This menu controls the brightness level of the keypad backlight. (Default is 3)

	STEP	DISPLAY
1.	Press Service Mode Button 	Motors (- -)
2.	Press 3	Options
3.	Press 9 to view setting.	KB Backlight
4.	Press 9 repeatedly to change setting. Note: 0=Off, 1=Low, 2=Med, 3=High, 4=Max	KB Backlight 3
5.	Press # to save	KB Backlight 3
6.	Press * 3 times to exit.	(Sales Mode)

3.0 DROP SENSOR SENSITIVITY (NOT APPLICABLE)

4 CONFIGURATION

This menu allows access to the following features.

- Item
- Row
- All
- Language
- Auto-reinstate
- Space to Sales (STS)
- Custom STS
- Date/ Time
- Health Safety (not applicable)
- Advanced Configuration

This menu provides access to sub-menus that set Can, Bottle or Snack type of product to each item, entire row or entire machine.

4.1 ALL (NOT APPLICABLE)

4.2 ROW (NOT APPLICABLE)



4.3 ITEM (NOT APPLICABLE)

4.4 LANGUAGE

Language Message -

This menu function allows the operator to choose a specific language in which sales mode messages will be displayed. The following languages are available:

- English
- Spanish
- French
- Italian
- German
- Danish
- Dutch
- Auxiliary

STEP		DISPLAY
1.	Press Service Mode Button 	Motors (- -)
2.	Press 4	Configuration
3.	Press 4	Language
4.	Press 4 to toggle between languages	English Spanish French Italian German Danish Dutch Auxiliary
5.	Press # to save.	Language
6.	Press Service Mode Button 	(Sales Mode)

NOTE: If **AUXILIARY** is selected, then an alternative list of operator created sales mode messages will be used. (See Section 7.3)

4.5 AUTO_REINSTATE

Auto-Reinstatement of Failed Selections - This feature is for a satellite soft drink or similar vendor utilizing a **Sold Out** or **Empty** switch. Normally, when an empty selection is detected during an attempted vend, that selection is recorded as inoperative and requires resetting before it can be vended again. Satellite units utilize a range of selections within the controller. Programming this range of selections into **Auto Reinstatement** will eliminate the necessity of manually resetting the controller after re-loading a selection that is in a **Sold Out** condition.

NOTE: If iVend™ Optical System is installed, then **ALL** selections are set to **AUTOREINST** "ON" unless changed.

4.5.1 AUTOREINSTATE WHOLE MACHINE

STEP		DISPLAY
1.	Press Service Mode Button 	Motors (- -)
2.	Press 4	Configuration
3.	Press 5	Autoreinstate
4.	Press 3 to toggle All ON/OFF	ALL ON
5.	Press # to save	ALL OFF
6.	Press * 3 times to exit	Sales Mode

4.5.2 AUTOREINSTATE BY ROW

STEP		DISPLAY
1.	Press Service Mode Button 	Motors (- -)
2.	Press 4	Configuration
3.	Press 5	Autoreinstate
4.	Press 2 to enter Row	Row - - - ON
5.	Press 1 to toggle ON/OFF	Row - - - OFF
6.	Press # to save	Row - - - OFF
7.	Press * to enter another row or 3 times to exit to Sales Mode	

4.5.3 AUTOREINSTATE BY ITEM

STEP		DISPLAY
1.	Press Service Mode Button 	Motors (- -)
2.	Press 4	Configuration
3.	Press 5	Autoreinstate
4.	Press 1 to enter Item	Item - - - ON
5.	Press 1 to toggle ON/OFF.	Item - - - OFF
6.	Press # to save.	Item - - - OFF
7.	Press * to enter another item or 3 times to exit to sales mode.	

4.6 SPACE TO SALES (STS)

The following settings are available: *Whole Rows; Half Rows; By 2's; Whole Machine; Custom*

NOTE: If custom is chosen. See section 4.7 for instructions.

STEP		DISPLAY
1.	Press Service Mode Button 	Motors (- -)
2.	Press 4	Configuration
3.	Press 6	STS Off
4.	Press 6 to toggle through options	STS: Whole Rows Half Rows By 2's Whole Machine Custom
5.	Press # to save setting	STS: Whole Rows
6.	Press * 3 times to exit	Sales Mode

4.7 CUSTOM STS

Before setting this option, you must select "Custom" as your setting under menu 4.6.

This option is used to tie selections together that do not fall under any of the categories under menu 4.6. (Example: 10; 20; 24)

STEP		DISPLAY
1.	Press Service Mode Button 	Motors (- -)
2.	Press 4	Configuration
3.	Press 6	STS
4.	Press 6 to toggle to Custom	STS: Custom
5.	Press # to save	
6.	Press * to exit	Configuration
7.	Press 7	STS - - :
8.	Enter first selection	STS 010:
9.	Press # to save	STS 010: 010
10.	Press # to add another selection	STS 010: 012
11.	Press # to save (to enter more selections repeat step 9 and 10)	STS 010: 010; 012 (the screen will display the selections that you have entered. After 3 selections the screen will scroll the selections.)
12.	Press * 3 times to exit	

4.8 TIME/DATE

Sets the time and date for timed operations.

The following submenus are available:

- Date
- Time
- Daylight Savings

4.8.1 DATE

STEP		DISPLAY
1.	Press Service Mode Button 	Motors (- -)
2.	Press 4	Configuration
3.	Press 8	Time/ Date menu
4.	Press 1	MM/DD/YYYY
5.	Press # to edit date	06/01/2007
6.	Press # to save.	06/01/2007
7.	Press * 4 times to exit	Sales Mode

4.8.2 TIME

Time Setting - This menu controls and displays the current time of day. The display will show a 24 hour format.

Examples:

8:05 a.m. = TIME 08.05
 01:15 p.m. = TIME 13.15
 11:45 p.m. = TIME 23.45

TIME SETTING

STEP		DISPLAY
1.	Press Service Mode Button 	Motors (- -)
2.	Press 4	Configuration
3.	Press 8	Date/ Time
4.	Press 2 for Time menu	08:00:25
5.	Press # to edit	09:00:25
6.	Press # to save	09:00:25
7.	Press * 4 times to exit	Sales Mode

DAYLIGHT SAVINGS

STEP		DISPLAY
1.	Press Service Mode Button 	Motors (- -)
2.	Press 4	Configuration
3.	Press 8	Date/ Time
4.	Press 3 for Daylight Savings menu	DST
5.	Press 3 to toggle between settings	N AMERICA OFF AUSTRALIA EUROPE
6.	Press # to save	DST N. AMERICA
7.	Press * 4 times to exit	Sales Mode

4.9 HEALTH SAFETY (NOT APPLICABLE)

4.0 ADVANCED CONFIGURATION

The following menus are available under this option:

- Beep Enable
- Optics Disables
- Motor Type
- Talker Password
- Set Defaults
- Temperature (not applicable)

4.0.1 BEEP ENABLE

Use this option to choose whether a sound is heard when buttons are pressed.

STEP		DISPLAY
1.	Press Service Mode Button 	Motors (- -)
2.	Press 4	Configuration
3.	Press 0	Password
4.	Enter Password (default 2314)	****
5.	Press 1 to toggle Beep ON/OFF	Beep Enable ON
6.	Press # to save	Beep Enable OFF
7.	Press * 4 times to exit	Sales Mode

4.0.2 OPTICS DISABLES (Not Applicable)

4.0.3 MOTOR TYPE (Not Applicable)

4.0.4 TALKER

Talker assists the vision impaired to service the machine.

STEP		DISPLAY
1.	Press Service Mode Button 	Motors (- -)
2.	Press 4	Configuration
3.	Press 0	Password
4.	Enter Password (default 2314)	****
5.	Press 4 to toggle Talker ON/OFF	Talker ON/OFF
6.	Press # to save	Talker ON
7.	Press * 4 times to exit	Sales Mode

4.0.5 PASSWORD (Not Applicable)

4.0.6 SET DEFAULTS (Not Applicable)

4.0.7 TEMP (Not Applicable)

5 PRICING

Price Setting - This menu allows three (3) methods for assigning prices:

- ITEM — by individual selections
- ROW— by shelf or tray
- ALL ITEMS — by entire machine.
- COUPONS — by Item, Row, or ALL
- TOKENS — by Item, Row, or ALL
- COMBO

The maximum price that can be set is \$655.35.

5.1 ALL

This menu allows you to set the selection price of every item all at once.

Time Saving Tip:

Instead of setting the price of each item one at a time, it is much faster to set the common price of the entire machine; then go back and set the price of each item or row.

	STEP	DISPLAY
1.	Press Service Mode Button	Motors (- -)
2.	Press 5	Pricing
3.	Press 3 to enter price	ALL Items \$0.50
4.	Press # to save.	ALL Items \$0.50
5.	Press * 3 times to exit.	(Sales Mode)

5.2 ROW

Use this menu to set the price of a row (shelf) all at the same time.

Time Saving Suggestion:

Instead of setting the price of one item at a time, set the common price of a Row, then go back and set the price of each item.

	STEP	DISPLAY
1.	Press Service Mode Button	Motors (- -)
2.	Press 5	Pricing
3.	Press 2	Row: - - \$0.00
4.	Enter row number and price <i>Example: Top row=01, row below top row=02, etc.</i> Program will automatically go to the next Row.	Row:01 \$0.50
5.	Press # to save.	Row 01 \$0.50
6.	Press * 3 times to exit	(Sales Mode)

5.3 ITEM

This menu allows price setting by each selection item.

	STEP	DISPLAY
1.	Press Service Mode Button	Motors (- -)
2.	Press 5	Pricing
3.	Press 1	Item
4.	Enter Item and price	Item 010 \$0.50
5.	Press # to save. The program will automatically go to the next selection number.	Item 010 \$0.50
6.	Press * 3 times to exit.	(Sales Mode)

5.4 COUPON

Allows the operator to designate the values of coupons that are accepted by pre-programmed validators. There are 5 programmable settings.

Value Coupon - This menu enables the use of coupons —this option requires a programmed validator [MDB version]. Several sub-menus are available that allows setting of the values of coupons. This feature also allows coupons to be set by Item, Row, or All.













If space to sales whole machine is "on" and you are setting Coupons by Row the Row must be set as row1.

NOTE: **Coupon Value Setting** - Sets the value of a coupon to be used with this vendor. Up to five different coupons can be set.

After one coupon is accepted, further coupons will not be accepted until a successful vend has taken place.















Note: If no value is set, coupons will be shown as free vends.

5.4.1 COUPON “ALL”

STEP		DISPLAY
1.	Press Service Mode Button 	Motors (- -)
2.	Press 	Price
3.	Press 	Coupons
4.	Press  for Coupon1	Coupon1
5.	Press  to toggle on/off	All ON/OFF
6.	Press  to save	All ON
7.	Press  to exit	Coupon1
8.	Press  to enter Coupon Value menu	Coupon1: \$0.00
9.	Press  to edit	Coupon1: \$1.50
10.	Press  to save	Coupon1: \$1.50
11.	Press  2 times to edit coupon 2-5 or press  3 times to exit menu	

5.4.2 COUPON BY ROW

COUPON BY ROW

STEP		DISPLAY
1.	Press Service Mode Button 	Motor Count
2.	Press 	Pricing
3.	Press 	Coupons
4.	Press  for Coupon1	Coupon1
5.	Press  to turn off “All Items”	All ON/OFF
6.	Press  to save	All OFF
7.	Press  to enter Row	Row 01 OFF
8.	Press  to toggle OFF/ON	Row: 01 ON
9.	Press  to save	Row: 01 ON
10.	Press  to exit	Coupon1
11.	Press  to enter Value menu	Coupon1: \$0.00
12.	Press  to edit value	Coupon1: \$1.50
13.	Press  to save	Coupon1: \$1.50
14.	Press  2 times to edit coupon2-5 or press  3 times to exit menu	

5.4.3 COUPON BY ITEM

STEP		DISPLAY
1.	Press Service Mode Button	Motors (- -)
2.	Press	Pricing
3.	Press for Coupon menu	Coupon
4.	Press for Coupon1	Coupon1
5.	Press to toggle ALL OFF	ALL ON/OFF
6.	Press to save	ALL OFF
7.	Press to enter Item	Item 010 OFF
8.	Press to toggle ON/OFF	Item 010 ON
9.	Press to save	Item 010 ON
10.	Press to exit	Coupon 1
11.	Press to enter Coupon Value menu	Coupon1\$0.00
12.	Press to edit value	Coupon1 \$1.00
13.	Press to save	Coupon1 \$1.00
14.	Press 2 times to edit Coupon 2-5 or press 3 times to exit to sales mode	

5.5 TOKEN

This option allows the operator to designate the values of tokens accepted by pre-programmed coin mechs.

Value Token- This menu enables the use of tokens; this option requires an MDB version coin mechanism/changer. Several sub-menus are available that allow setting token values. This feature also allows settings by Item, Row, or All
If "Space to Sales Whole Machine" is "ON", and you are setting Tokens by Row, the Row must be set to Row1.

5.5.1 TOKEN "ALL"

STEP		DISPLAY
1.	Press Service Mode Button	Motors (- -)
2.	Press	Pricing
3.	Press	Token1
4.	Press to toggle ON/ OFF	All ON/OFF
5.	Press to save	All ON
6.	Press to exit	Token1
7.	Press to enter Value menu	Token1: \$0.00
8.	Press to edit	Token1: \$1.00
9.	Press to save	Token1: \$1.00
10.	Press 2 times to edit token 2-5 or press 3 times to exit	

5.5.2 TOKEN BY ROW

STEP		DISPLAY
1.	Press Service Mode Button	Motors (- -)
2.	Press	Pricing
3.	Press	Token1
4.	Press for Token1	Token1
5.	Press to toggle; turn "all OFF"	All ON/OFF

6.	Press # to save	All OFF
7.	Press * to exit	Token1
8.	Press 2 to set by Row Enter Row	Row - - Row 01 OFF/ON
9.	Press 1 to toggle ON/OFF	Row 01 ON
10.	Press # to save	Row 01 ON
11.	Press * to exit	Token1
12.	Press 4 to enter Value menu	Token1: \$0.00
13.	Press # to edit	Token1: \$1.00
14.	Press # to save	Token1: \$1.00
15.	Press * 2 times to edit token 2-5 or press * 3 times to exit	

5.5.3 TOKEN BY ITEM

	STEP	DISPLAY
1.	Press Service Mode Button ■	Motors (- -)
2.	Press 5	Pricing
3.	Press 5	Tokens
4.	Press 1 for Token1	Token1
5.	Press 3 to turn off "ALL"	All ON/OFF
6.	Press ■ to save	All OFF
7.	Press * to exit	Token1
8.	Press 1 to enter Item Enter item number	Item - - - Item 010
9.	Press 1 to toggle on/off	Item 010 ON/OFF
10.	Press # to save	Item 010 ON
11.	Press * to exit	Token1
12.	Press 4 to enter Value menu	Token1: \$0.00
13.	Press # to edit value	Token1: \$1.50
14.	Press # to save	Token1: \$1.50
15.	Press * 2 times to edit coupon 2-5 or press * 3 times to exit menu	

5.7 COMBO

	STEP	DISPLAY
1.	Press Service Mode Button ■	Motors (- -)
2.	Press 5	Pricing
3.	Press 7 to enter Combo menu (There are 5 available combo settings. For Combo 2 press 2 ; 3 press 2 ; etc. and follow the steps below.)	Combo
4.	Press 1 for Combo 1	Combo1: - - - \$0.00
5.	Enter Combo number and price	Combo1: 090 \$1.00
6.	Press # to save	Combo1: 090 \$1.00
7.	Press 1 to set Range1	010-020

8.	Press # to save	010-020
9.	There are 5 settable ranges. To continue setting ranges repeat steps 7 & 8. When finished press * repeatedly to exit out of the menu.	

6 ACCOUNTING

Use this menu to gain access to menus that display or reset data for various types of cash and vend totals. Counts can be viewed by individual items, rows or as the whole machine.

Historical totals: These are the counts since the initialization of the machine. They cannot be reset.

Resettable totals: These are totals since the last reset. These can be reset at any time. You have the option to reset just an item, row or the whole machine.

****Clearing by item and row will only clear the item or row entered. ****

6.1 ACCOUNTING "ALL"

This menu displays the total sales value and total vend count for the entire machine.
This will include satellite machines.

Confirming clear will clear **ONLY** the resettable counts for ALL ITEMS.

ACCOUNTING ALL		
	STEP	DISPLAY
1.	Press Service Mode Button ■	Motors (- -)
2.	Press 6	Accounting
3.	Press 3	All
4.	Press 1 Hist. Ct	Hist. Ct. 10
5.	Press 2 Hist. Cash	Hist. Cash \$10.00
6.	Press 3 Reset. Ct.	Res. Count 10
7.	Press 4 Reset Cash	Res. Cash \$10.00
8.	Press 5 Hist. Card	Hist. Card \$0.00
9.	Press 6 Hist. 2 nd Vends	Hist. 2 nd Vends 0
10.	Press 7 Reset. Card	Res Card \$0.00
11.	Press 8 Reset 2 nd Vends	Res 2 nd Vends 0
12.	Press 0 to clear all selections	Clear?
13.	Press 0 to confirm clear	Cleared
14.	Press * 3 times to exit	Sales Mode

6.2 ACCOUNTING BY ROW

	STEP	DISPLAY
1.	Press Service Mode Button ■	Motors (- -)
2.	Press 6	Accounting
3.	Press 2 to enter row	Row 01
4.	Press 1 Hist. Ct.	Hist. Ct. 10
5.	Press 2 Hist. Cash	Hist. Cash \$10.00
6.	Press 3 Reset. Ct.	Reset. Ct. 10
7.	Press 4 Reset Cash	Reset Cash \$10.00
8.	Press 5 Hist. Card	Hist. Card \$0.00

9.	Press 6 Hist. 2 nd Vends	Hist. 2 nd vends 0
10.	Press 7 Reset Card	Reset Card \$0.00
11.	Press 8 Reset 2 nd vends	Reset 2 nd Vends 0
12.	Press 0 to clear Resettables	Clear?
13.	Press 0 to confirm clear	Cleared
14.	Press * to enter another row or press * 4 times to exit	Sales Mode

6.3 ACCOUNTING BY ITEM

	STEP	DISPLAY
1.	Press Service Mode Button ■	Motors (- -)
2.	Press 6	Acct
3.	Press 1 to enter an item	Item 010
4.	Press 1 Hist. ct.	Hist Ct. 10
5.	Press 2 Hist. cash	Hist Cash \$10.00
6.	Press 3 Reset. Ct..	Reset Ct. 10
7.	Press 4 Reset. Cash	Reset. Cash \$10.00
8.	Press 5 Hist. Card	Hist. Card \$0.50
9.	Press 6 Hist 2 nd vends	Hist. 2nd vends 2
10.	Press 7 Reset. Card	Reset Card \$0.50
11.	Press 8 Reset 2 nd vends	Reset 2nd Vends 2
12.	Press 0 to clear Resettables	Clear?
13.	Press 0 to confirm clear	Cleared

7 ADVANCED OPTIONS

To enter this menu you will be prompted to input a password. The following options are available:

- Discount
- Promo Vend
- Free Vend Rate
- Exact Change
- Unconditional Acceptance
- Max Change
- Programmable POS
- Shutdown
- Energy Savings

7.1 DISCOUNT

This menu will access the following sub-menus that allow the vending machine (controller) to charge a different price for selections at different times or on different days:

- Item
- Row
- All
- Start Time
- Day
- Stop Time
- Value
- Enable ON/OFF



































7.1.1 DISCOUNT "ALL"

	STEP	DISPLAY
1.	Press Service Mode Button ■	Motors (- -)
2.	Press 7	Password
3.	Enter Password (default 2314)	****
4.	Press 1	Discount
5.	Press 3 to toggle All ON/OFF	ALL ON/OFF
6.	Press # to save	ALL ON

If Every Day "ON" is your setting skip to step #27
To set individual days use steps 12-27

7.	Press * to exit to Discount	Discount
8.	Press 4 to enter day menu	Day
9.	Press 1 to toggle Every Day ON/OFF (To set individual days turn Every Day OFF)	Every Day ON/OFF
10.	Press # to save	ALL Days ON
11.	Press 2 to toggle Mon. ON/OFF	Mon ON/OFF
12.	Press # to save	Mon ON
13.	Press 3 to toggle Tues ON/OFF	Tues ON/OFF
14.	Press # to save	Tues OFF
15.	Press 4 to toggle Wed ON/OFF	Wed ON/OFF
16.	Press # to save	Wed ON
17.	Press 5 to toggle Thurs. ON/OFF	Thurs. ON/OFF
18.	Press # to save	Thurs. ON
19.	Press 6 to toggle Fri On/OFF	Fri On/OFF
20.	Press # to save	Fri OFF
21.	Press 7 to toggle Sat On/OFF	Sat ON/OFF
22.	Press # to save	Sat ON
23.	Press 8 to toggle Sun ON/OFF	Sun ON/OFF
24.	Press # to save	Sun OFF
25.	Press * 2 times to exit to Discount menu	Discount
26.	Press 5 2 times to enter Start Time menu	Start Time 00:00
27.	Press # to edit	08:00
28.	Press # to save	08:00
29.	Press * to exit to Start Time	Start Time
30.	Press 6 2 times to enter Stop Time menu	Stop Time 23:59
31.	Press # to edit	10:00
32.	Press # to save	10:00
33.	Press * 2 times to exit to Discount menu	Discount
34.	Press 7 to enter Disc. Value	Disc. \$0.50
35.	Press # to save	Disc. \$0.50
36.	Press * 2 times to exit to discount menu	Discount
37.	Press 9 to toggle enable ON/OFF	Enable ON/OFF
38.	Press # to save	Enable ON
39.	Press * 4 times to exit to Sales Mode	Sales Mode

7.1.2 DISCOUNT BY ROW

	STEP	DISPLAY
1.	Press Service Mode Button 	Motors (- -)
2.	Press 	Password
	Enter Password (default 2314)	****
3.	Press 	Discount
	Press  to toggle and turn off All	All OFF
4.	Press  to save	All OFF
5.	Press  to exit to Discount menu	Discount
6.	Press  for Row Enter row	Row - - Row 01 OFF/ON
7.	Press  to toggle OFF/ON	Row 01 ON
8.	Press  to save	Row 01 ON
9.	Press  once to enter another row or 2 times to go to Discount menu	Discount
10.	Press  to enter Day menu	Day
11.	Press  to toggle All days ON/OFF (To set individual days turn Every Day off)	Every Day ON/OFF
12.	Press  to save	All days ON
13.	Press  to toggle Mon. ON/OFF	Mon ON/OFF
14.	Press  to save	Mon ON
15.	Press  to toggle Tues ON/ OFF	Tues ON/OFF
16.	Press  to save	Tues OFF
17.	Press  to toggle Wed ON/OFF	Wed ON/OFF
18.	Press  to save	Wed OFF
19.	Press  to toggle Thurs. ON/OFF	Thurs ON/ OFF
20.	Press  to save	Thurs ON/OFF
21.	Press  to toggle Fri. ON/OFF	Fri ON/OFF
22.	Press  to save	Fri ON
23.	Press  to toggle Sat. ON/ OFF	Sat. ON/OFF
24.	Press  to save	Sat. OFF
25.	Press  to toggle Sun. ON/OFF	Sun ON/OFF
26.	Press  to save	Sun OFF
27.	Press  2 times to exit to Discount menu	Discount
28.	Press  2 times to enter Start Time menu	Start Time 00:00
29.	Press  to edit start time enter in 24hr time (HH:MM)	08:00
30.	Press  to save	08:00
31.	Press  2 times to enter stop time menu	Stop Time 23:59
32.	Press  to edit	10:00
33.	Press  to save	10:00

If Everyday "ON" is your setting skip to step # 27
To set individual days use steps 13-27

34.	Press * 2 times to exit to Discount menu	Discount
35.	Press 7 to enter disc. Value	Disc. \$0.50
36.	Press # to save	Disc. \$0.50
37.	Press * 2 times to exit to Discount menu	Discount
38.	Press 9 to toggle ON/OFF	Enable ON/OFF
39.	Press # to save	Enable ON
40.	Press * 4 times to exit	Sales Mode

7.1.3 DISCOUNT BY ITEM

If Every Day "ON" is your setting skip to step #27

To set individual days use steps 13-27

	STEP	DISPLAY
1.	Press Service Mode Button	Motors (- -)
2.	Press 7	Password
3.	Enter Password (default 2314)	****
4.	Press 1	Discount
5.	Press 3 to toggle ALL items OFF	ALL ON/ OFF
6.	Press # to save	ALL OFF
7.	Press 1 to enter an Item	Item 010 OFF
8.	Press 1 to toggle Item ON	Item 010 ON
9.	Press # to save	Item 010 ON
10.	Press 4 to enter Day menu	Day
11.	Press 1 to toggle Everyday ON/OFF (To set individual days Everyday must be OFF)	Everyday ON/OFF
12.	Press # to save	Everyday ON
13.	Press 3 to toggle Tues ON/OFF	Tues ON/OFF
14.	Press # to save	Tues OFF
15.	Press 4 to toggle Wed ON/OFF	Wed ON/OFF
16.	Press # to save	Wed ON
17.	Press 5 to toggle Thurs. ON/OFF	Thurs. ON/OFF
18.	Press # to save	Thurs. ON
19.	Press 6 to toggle Fri On/OFF	Fri On/OFF
20.	Press # to save	Fri OFF
21.	Press 7 to toggle Sat On/OFF	Sat ON/OFF
22.	Press # to save	Sat ON
23.	Press 8 to toggle Sun ON/OFF	Sun ON/OFF
24.	Press # to save	Sun OFF
25.	Press * 2 times to exit to Discount menu	Discount
26.	Press 5 2 times to enter Start Time menu	Start Time 00:00
27.	Press # to edit	08:00
28.	Press # to save	08:00

29.	Press * to exit	Start Time
30.	Press 6 2 times to enter Stop Time menu	Stop Time 23:59
31.	Press # to edit	10:00
32.	Press # to save	10:00
33.	Press * 2 times to exit to Discount menu	Discount
34.	Press 7 to enter Disc. Value	Disc. \$0.50
35.	Press # to save	Disc. \$0.50
36.	Press * 2 times to exit to Discount menu	Discount
37.	Press 9 to toggle Enable ON/OFF	Enable ON/OFF
38.	Press # to save	Enable ON
39.	Press * 4 times to exit	Sales Mode

7.2 PROMO VEND

Promotional Vend -

This function allows a free promotional product to be given to a customer in response to their purchase of another product.

Examples: 1) Purchase of selection #32 will give away #34; 2) Purchase selection #53 will give away #54. (Examples only—you are not limited to only 2 promo vends)

	STEP	DISPLAY
1.	Press Service Mode Button 	Motors (- -)
2.	Press 7	Password
3.	Enter password (default 2314)	****
4.	Press 2	Promo Vend
5.	Press 4 to toggle ON/OFF	Promo Vend ON/OFF
6.	Press # to save	Promo Vend ON
7.	Press * to exit	Promo Vend
8.	Press 1 to enter item	Item 012 OFF
9.	Press 1 to toggle ON/OFF	Item 012 ON
10.	Press # to save	Item 012 ON
11.	Press * 3 times to exit	Sales Mode

7.3 FREE VEND RATE

Enter a number from 0-255.

This will set the number of paid vends between free vends.

Example: If set at 5; every 5th vend will be free.

STEP		DISPLAY
1.	Press Service Mode Button 	Motors (- -)
2.	Press 7	Password
3.	Enter Password (default 2314)	****
4.	Press 3 to enter Free Vend Rate menu	Free Vend Rate
5.	Press # to edit	Free Vend Rate 10
6.	Press # to save	Free Vend Rate 10
7.	Press * 3 times to exit	Sales Mode

7.4 EXACT CHANGE

Exact Change - Sets the exact change value which also triggers the display of the *Please Use Exact Change* message.

STEP		DISPLAY
1.	Press Service Mode Button 	Motors (- -)
2.	Press 7	Password
	Enter Password (default 2314)	****
3.	Press 4	Exact Change \$0.00
4.	Press # to edit	Exact Change \$1.00
5.	Press # to save	Exact Change \$1.00
6.	Press * 3 times to exit.	(Sales Mode)

*****If "Uncond. Accept." is set, for example, at \$20.00, exact change will also be \$20.00 and cannot be set for a lower amount.*****

7.5 UNCONDITIONAL ACCEPTANCE

Unconditional Acceptance
- Sets the unconditional acceptance value. All coins or bills equal to or less than this set value will be accepted even if the changer cannot return an equal amount of change.

STEP		DISPLAY
1.	Press Service Mode Button 	Motors (- -)
2.	Press 7	Password
3.	Enter Password (default-2314)	****
4.	Press 5	Uncond. Accept \$0.00
5.	Press # to edit	Uncond. Accept \$5.00
6.	Press # to save	Uncond. Accept \$5.00
7.	Press * 3 times to exit.	(Sales Mode)

The Unconditional Acceptance set value is adjustable but the maximum value is equal to the largest denomination of currency or coin accepted by the changer or validator.

7.6 MAX CHANGE

Maximum Change Option
- This option will prevent change from being returned to the customer until the amount of credit has been reduced to a value less than or equal to the

STEP		DISPLAY
1.	Press Service Mode Button 	Motors (- -)
2.	Press 7	Password
	Enter Password (default is 2314)	****
3.	Press 6	MAX CHANGE

programmed maximum change limit.

Note:

The highest value that can be set for the maximum price is 655.35 for a scale factor of 1 and 999.95 for a scale factor of 5.

4.	Press 1 to toggle ON/OFF	Max Change OFF/ON
5.	Press # to save	Max Change ON
6.	Press 2 to enter dollar amt.	Max Change \$50.00
7.	Press # to save	Max Change \$50.00
8.	Press numbers on keypad.	
9.	Press * 3 times to exit.	(Sales Mode)

7.7 PROGRAMMABLE POS MESSAGE

These are messages that can be edited. You must first turn off the default POS message under the options menu.

7.7.1 PROGRAMMING the POS MESSAGE

STEP		DISPLAY
1.	Press Service Mode Button 7	Motors (- -)
2.	Press 7	Password
3.	Enter Password (default is 2314)	****
4.	Press 7	Programmable POS
5.	Press 1 to toggle ON/OFF	Programmable POS OFF/ ON
6.	Press # to save	Prog. POS ON
7.	Press 2 to enter message	...Enjoy A Snack
8.	Press 1 , 4 , 7 ; to move cursor to the left Press 3 , 6 , 9 ; to move cursor to the right Press 2 , 5 , 8 ; to move the cursor from top to bottom. Once the cursor is in the place you want to edit press # In edit mode 0 is space key, * is backspace # saves	
9.	Press # to save new message	
10.	Press * 4 times to exit	Sales Mode

****To edit the messages under #3 the language must be in Aux. mode****

7.7.2 AUXILLARY MESSAGES

STEP		DISPLAY
1.	Press Service Mode Button 7	Motors (- -)
2.	Press 4	Configuration
3.	Press 4 2 times to toggle to set language to auxiliary	Language: auxiliary
4.	Press # to save	
5.	Press * 2 times to exit configuration menu	
6.	Press 7 and enter password (default is 2314)	****
7.	Press 7 Programmable POS	
8.	Press 3 to enter auxiliary messages	
9.	Press 1 to toggle through messages.	
10.	Press # to edit the selected message. Press 1 , 4 , 7 ; to move cursor to the left Press 3 , 6 , 9 ; to move cursor to the right	

	Press 2 ; 5 ; 8 to move the cursor from top to bottom. Once the cursor is in the place you want to edit press # In edit mode 0 is space key, * is backspace; # saves	
11.	Press # to save	
12	Press * 3 times to exit or to edit more messages Press 1 and follow step 10.	

7.7.3 TIME DISPLAY

This option will display the time and date. Programmable POS does not have to be “ON” for this to work.

		STEP	DISPLAY
Default Password 2314 Default is OFF	1.	Press Service Mode Button 	Motors (- -)
	2.	Press 7 and enter password	****
	3.	Press 7	Programmable POS
	4.	Press 4 to enter time display menu	Time Display: OFF
	5.	Press 4 to toggle on and off	Time Display: ON
	6.	Press # to save	Time Display: ON
	7.	Press * 4 times to exit	Sales Mode

7.8 SHUTDOWN

This option allows the controller to shut down a range of selections or the entire machine based on four (4) time-of-day intervals. If the time falls within one of these intervals and the entire machine has been selected for shutdown then the message **VENDING OPERATION TO RESUME AT hh.mm** is displayed.

If a range of selections has been chosen for shutdown that does not encompass the entire machine, the same message will display once every time the customer makes a selection that falls within the range.

Note: The correct time and date must be set so that the **SHUTDOWN** intervals work correctly. Refer to page 14. Also, for any given day these 4 time intervals may overlap one another. For each interval, the machine (controller) can be programmed from no days up to every day of the week on which the specified shutdown time intervals will be active.

7.8.1 Shutdown ALL

		STEP	DISPLAY
If Everyday “ON” is your setting skip to step # 27 To set individual days use steps 13-27	1.	Press Service Mode Button 	Motors (- -)
	2.	Press 7	Password
	3.	Enter Password (default is 2314)	****
	4.	Press 8	Shutdown
	5.	Press 1 for Interval1	Interval1
	6.	Press 3 to toggle All ON	All OFF/ON
	7.	Press # to save	All ON
	8.	Press * to exit	Interval1
	9.	Press 4 to enter day menu	Day
	10.	Press 1 to toggle Everyday ON/OFF (To program individual days turn Everyday OFF)	Everyday ON/OFF
	11.	Press # to save	Everyday ON
	12.	Press 2 to toggle Mon ON/OFF	Mon ON/OFF
	13.	Press # to save	Mon ON
	14.	Press 3 to toggle Tues ON/OFF	Tues. ON/OFF

15.	Press # to save	Tues. OFF
16.	Press 4 to toggle Wed ON/OFF	Wed. ON/OFF
17.	Press # to save	Wed OFF
18.	Press 5 to toggle Thurs. ON/OFF	Thurs. ON/OFF
19.	Press # to save	Thurs. ON
20.	Press 6 to toggle Fri. ON/OFF	Fri. ON/OFF
21.	Press # to save	Fri. ON
22.	Press 7 to toggle Sat. ON/OFF	Sat. ON/OFF
23.	Press # to save	Sat. OFF
24.	Press 8 to toggle Sun. ON/OFF	Sun. ON/OFF
25.	Press # to save	Sun. ON
26.	Press * 2 times to exit	Interval1
27.	Press 5 2 times to enter start time menu	Start Time 00:00
28.	Press # to edit	08:00
29.	Press # to save	08:00
30.	Press * to exit	Start Time
31.	Press 6 2 times to enter stop time menu	Stop Time 23:59
32.	Press # to edit	10:00
33.	Press # to save	10:00
34.	Press * 2 times to exit to Interval menu	Interval1
35.	Press 8 to toggle Lighting ON/OFF Lighting ON-tURNS OFF lights during shutdown Lighting OFF- leaves lights On during shutdown	Lighting On/OFF
36.	Press # to save	Lighting ON
35.	Press 9 to toggle enable ON/OFF	Enable ON/OFF
36.	Press # to save	Enable ON
37.	Press * 2 times to edit Interval 2-4	Shutdown
38.	Press * 3 times to exit to sales mode	Sales Mode

(35) **NOTE:** Machine must be equipped with optional light relay.
Default setting is OFF

7.8.2 SHUTDOWN BY ROW

	STEP	DISPLAY
1.	Press Service Mode Button	Motors (- -)
2.	Press 7	Password
3.	Enter Password (default is 2314)	****
4.	Press 8	Shutdown
5.	Press 1 for Interval1	Interval1
6.	Press 2 to set Row Enter Row	Row - - Row 01 OFF
7.	Press 1 to toggle Row ON	Row 01 ON

If Everyday "ON" is your setting skip to step # 27

To set individual days use steps 13-27

8.	Press # to save	Row 01 ON
9.	Press * to enter another Row or press * 2 times to return to Interval menu	Interval1
10.	Press 4 to enter Day menu	Day
11.	Press 1 to toggle Everyday ON/OFF (To program individual days turn everyday OFF)	Everyday ON/OFF
12.	Press # to save	Everyday ON
13.	Press 2 to toggle Mon ON/OFF	Mon ON/OFF
14.	Press # to save	Mon ON
15.	Press 3 to toggle Tues ON/OFF	Tues. ON/OFF
16.	Press # to save	Tues. OFF
17.	Press 4 to toggle Wed ON/OFF	Wed. ON/OFF
18.	Press # to save	Wed OFF
19.	Press 5 to toggle Thurs. ON/OFF	Thurs. ON/OFF
20.	Press # to save	Thurs. ON
21.	Press 6 to toggle Fri. ON/OFF	Fri. ON/OFF
22.	Press # to save	Fri. ON
23.	Press 7 to toggle Sat. ON/OFF	Sat. ON/OFF
24.	Press # to save	Sat. OFF
25.	Press 8 to toggle Sun. ON/OFF	Sun. ON/OFF
26.	Press # to save	Sun. ON
27.	Press * 2 times to exit	Interval1
28.	Press 5 2 times to enter start time menu	Start Time 00:00
29.	Press # to edit	08:00
30.	Press # to save	08:00
31.	Press * to exit	Start Time
32.	Press 6 2 times to enter stop time menu	Stop Time 23:59
33.	Press # to edit	10:00
34.	Press # to save	10:00
35.	Press * 2 times to exit to Interval menu	Interval1
36.	Press 9 to toggle enable ON/OFF	Enable ON/OFF
37.	Press # to save	Enable ON
38.	Press * 2 times to edit Interval 2-4	Shutdown
39.	Press * 3 times to exit to sales mode	Sales Mode

7.8.3 SHUTDOWN BY ITEM

STEP		DISPLAY
1.	Press Service Mode Button ■	Motors (- -)
2.	Press 7	Password
	Enter Password (default is 2314)	****



If Everyday "ON" is your setting skip to step # 27
To set individual days use steps 12-27

3.	Press 8	SHUTDOWN
4.	Press 1 for Interval1	Interval1
5.	Press 1 to enter item	Item 010 OFF
6.	Press 1 to toggle ON/OFF	Item 010 ON
7.	Press # to save	Item 010 ON
8.	Press * to enter another item or press * 2 times for Interval1 menu	Interval1
9.	Press 4 to enter day menu	Day
10.	Press 1 to toggle Everyday ON/OFF (To program individual days turn Everyday OFF)	Everyday ON/OFF
11.	Press # to save	Everyday ON
12.	Press 2 to toggle Mon ON/OFF	Mon ON/OFF
13.	Press # to save	Mon ON
14.	Press 3 to toggle Tues ON/OFF	Tues. ON/OFF
15.	Press # to save	Tues. OFF
16.	Press 4 to toggle Wed ON/OFF	Wed. ON/OFF
17.	Press # to save	Wed OFF
18.	Press 5 to toggle Thurs. ON/OFF	Thurs. ON/OFF
19.	Press # to save	Thurs. ON
20.	Press 6 to toggle Fri. ON/OFF	Fri. ON/OFF
21.	Press # to save	Fri. ON
22.	Press 7 to toggle Sat. ON/OFF	Sat. ON/OFF
23.	Press # to save	Sat. OFF
24.	Press 8 to toggle Sun. ON/OFF	Sun. ON/OFF
25.	Press # to save	Sun. ON
26.	Press * 2 times to exit	Interval1
27.	Press 5 2 times to enter Start Time menu	Start Time 00:00
28.	Press # to edit	08:00
29.	Press # to save	08:00
30.	Press * to exit	Start Time
31.	Press 6 2 times to enter Stop Time menu	Stop Time 23:59
32.	Press # to edit	10:00
33.	Press # to save	10:00
34.	Press * 2 times to exit to Interval menu	Interval1
35.	Press 9 to toggle enable ON/OFF	Enable ON/OFF
36.	Press # to save	Enable ON
37.	Press * 2 times to edit Interval 2-4	Shutdown
38.	Press * 3 times to exit to Sales mode	

8 ENERGY SAVINGS (NOT APPLICABLE)

9 TEST

Use this menu to test vend individual motors. The selection will display with the test vend. If a test vend attempt on a particular motor fails, controller will beep.



	STEP	DISPLAY
1.	Press Service Mode Button 	Motors (- -)
2.	Press 	Item - - -
3.	Press selection number on keypad and wait	Item 010
4.	Repeat step 3 for other selections.	
5.	Press  3 times to exit.	(Sales Mode)

TEST ALL MOTORS

This menu will test vend all motors. The selection will display with the test vend. If a test vend attempt on a particular motor fails, then the controller will beep. Satellite machines will also be included in the test.





NOTE:

Pressing  at any time will stop the test.

	STEP	DISPLAY
1.	Press Service Mode Button 	Motors (- -)
2.	Press  and wait.	Item
	The motor selection number will display while it is being tested.	Item 010
3.	Press  3 times to exit.	(Sales Mode)

0 DIAGNOSTIC

This menu is used to perform a self-diagnostics check and display results.

	STEP	DISPLAY
1.	Press Service Mode Button 	Motors (- -)
2.	Press 	Diagnostic...
	Press  to start test	Checksum Temp Sensor Optical Coin Acceptor Bill Validator Card Reader1 Card Reader2 Tests Completed
3.	Press  3 times to exit.	(Sales Mode)

0.2 TEST RELAY (NOT APPLICABLE)

0.3 LOG

Engineering download for service technician ONLY!

STEP		DISPLAY
1.	Press Service Mode Button 	Motors (- -)
2.	Press 1	Diagnostics
3.	Press 3	Log
4.	Press * 3 times to exit	Sales Mode

0.4 COIN REJECT RATE

This feature tracks the percentage of coins that have been rejected by the coin mech. This will be reset when in accounting "ALL" has been cleared.

STEP		DISPLAY
1.	Press Service Mode Button 	Motors (- -)
2.	Press 0	Diagnostics
3.	Press 4 to view percentage	Coin Rej. Rate 10%
4.	Press * 3 times to exit	Sales Mode

0.5 BILL REJECT RATE

STEP		DISPLAY
1.	Press Service Mode Button 	Motors (- -)
2.	Press 0	Diagnostics
3.	Press 5 to view percentage	Bill Rej. Rate 20%
4.	Press * 3 times to exit	Sales Mode

0.6 IVEND ALIGNED

STEP		DISPLAY
1.	Press Service Mode Button 	Motors (- -)
2.	Press 0	Diagnostics
3.	Press 6 to check I-vend alignment	IVend aligned NO/OK

CUSTOMER LEAD THROUGH MESSAGES

The following messages will be affected by the language selection and are stored in the controller memory.

MESSAGE 1	
English	PLEASE USE EXACT CHANGE
Spanish	POR FAVOR DEPOSITE CANTIDAD EXACTA
French	FAITES L'APPOINT S'IL VOUS PLAIT
Italian	PER FAVORE INTRODURRE I PRECISI SOLDI
German	ABGEZAHLTES GELD EINWERFEN
Danish	INDKAST AFTALTE PENGE
Dutch	AFGEPAST GELD IN WERPEN
Auxiliary	[maximum length: 30]
MESSAGE 2	
English	PLEASE INSERT MORE MONEY
Spanish	POR FAVOR DEPOSITE MAS DINERO
French	MONTANT INSUFFISANT INTRODUISEZ D'AUTRES PIECES
Italian	PER FAVORE INTRODURRE PIU SOLDI
German	INDKAST FLERE PENGE
Danish	MEHR GELD EINWERFEN
Dutch	MEER GELD IN WERPEN
Auxiliary	[maximum length: 30]

MESSAGE 3	
English	PLEASE MAKE ANOTHER SELECTION
Spanish	SELECCIONE OTRO PRODUCTO
French	FAITES UNE AUTRE SELECTION
Italian	FARE UNA ALTRE SCELTA
German	ANDERE WARE WAHLEN
Danish	VAELG ANDEN VARE
Dutch	ANDERE KEUZE MAKEN
Auxiliary	[maximum length: 25]

MESSAGE 4	
English	OUT OF SERVICE
Spanish	FUERO DE SERVICIO
French	DEMANDEZ LE RESPONSABLE
Italian	PER FAVORE CHIAMARE SERVIZIO
German	BITTE KUNDENDIENST RUFEN
Danish	TILKALD SERVICEMONTOR
Dutch	SERVICEDIENST BELLEN
Auxiliary	[maximum length: 25]

MESSAGE 5	
English	VENDING OPERATION TO RESUME AT hh.mm
Spanish	MAQUINA ENCINDE A LAS hh.mm
French	VENDING OPERATION TO RESUME AT hh.mm
Italian	VENDING OPERATION TO RESUME AT Hamm
German	VENDING OPERATION TO RESUME AT hh.mm
Danish	VENDING OPERATION TO RESUME AT hh.mm
Dutch	VENDING OPERATION TO RESUME AT hh.mm
Auxiliary	[maximum length: 25]

MESSAGE 6:	
English	DOOR OPEN ERROR
Italian	DOOR OPEN ERROR
Dutch	DOOR OPEN ERROR
Spanish	DOOR OPEN ERROR
Danish	DOOR OPEN ERROR
French	DOOR OPEN ERROR
German	DOOR OPEN ERROR
Auxiliary	[maximum length: 25]

MESSAGE 7	
English	THANK YOU
Italian	GRAZIE
Dutch	DANK U
Spanish	GRACIAS
Danish	TAK
French	MERCI
German	VIEL. DANK
Auxiliary	[maximum length: 10]

MESSAGE 8	
English	FREE ON US
Italian	FREE *
Dutch	FREE **
Spanish	FREE ***
	Only: GRATIS
Danish	FREE ****
French	FREE *****
German	FREE*****
Auxiliary	[maximum length: 10]

PREVENTATIVE MAINTENANCE

CAUTION: ALWAYS DISCONNECT POWER SOURCE BEFORE CLEANING OR SERVICING

WARNING: THIS VENDING MACHINE MUST NOT BE CLEANED WITH A WATER JET.

ONCE A MONTH

CLEAN CABINET INTERIOR

- Wash with a mild detergent and water, rinse and dry thoroughly.
- Odors may be eliminated by including baking soda or ammonia in the cleaning solution.
- Plastic parts may be cleaned with a quality plastic cleaner.
- The vend mechanism must be kept clean. Any build-up can cause the mechanisms to malfunction.
- Do not get the cleaning solution on electrical components.
- To insure proper vending keep delivery slide area free of dirt and sticky substances.

CLEAN CABINET EXTERIOR

- Wash with a mild detergent and water, rinse and dry thoroughly.
- Clean occasionally with a quality car wax or cleaner.

PARTS ORDERING PROCEDURE

When ordering parts, include the following:

- Model and serial number of the machine
- Shipping address
- Address where the invoice should be sent
- Quantity of parts ordered
- Any special shipping instructions
- Desired carrier: air or air special, truck, parcel post, or rail.
- Signature and ordering date.
- If a purchase order is used, be sure it is visible and legible

Please be sure that you refer to the correct part number, machine model number, and machine serial number when ordering. These can be confirmed by checking the parts manual.

NOTE: "Left" or "Right" when used in the name or description of the part are determined while facing the front of the vending machine with the door closed.

Mail order to:

VendNet™
165 North 10th Street
Waukee, IA 50263
USA

You may also order via E-mail to vendnet@vendnetusa.com; online at www.vendnetusa.com; phone at 1-800-833-4411; or fax at 1-515-271-8555.

All orders are carefully packed and inspected prior to shipment. Damage incurred during shipment should be reported at once and a claim filed with the terminating carrier.

If you do not have the correct parts manual, contact VendNet™

Answers to other questions may be found at www.vendnetusa.com or call VendNet™ at 1(800)833-4411. Ask for the Parts Department. We will be happy to assist you. You may also e-mail VendNet™ at vendnet@vendnetusa.com.

BEFORE CALLING FOR SERVICE

Please check the following:

- Does your machine have at least 6 inches (15.2 cm) of clear air space behind it?
- If the power is turned on at the fuse box, is the machine the only thing that does not work?
- Is the machine plugged directly into the outlet?

WARNING: Do not use extension cords!

Is the circuit breaker at the fuse box reset?

NOTE: Please have your Model and Serial Number handy when you call.

NOTES:

The contents of this publication are presented for informational purposes only, and while every effort has been made to ensure their accuracy, they are not to be construed as warranties or guarantees, express or implied, regarding the products or services described herein or their use or applicability. We reserve the right to modify or improve the designs or specifications of such products at any time without notice.



VendNet™
165 North 10th Street
Waukee, Iowa 50263
United States of America



	USA & Canada	International
Service	(800) 833-4411	(515) 274-3641
Parts	(888) 259-9965	
Email	vendnet@vendnetusa.com	
Web Site	www.vendnetusa.com	