



## TABLE OF CONTENTS

<b>GENERAL INFORMATION.....</b>	<b>1</b>
<b>FINAL ASSEMBLY .....</b>	<b>2,3</b>
<b>CABINET ASSEMBLY .....</b>	<b>4,5</b>
<b>ELECTRIC BOX ASSEMBLY, BK LFT .....</b>	<b>6</b>
<b>ELECTRIC BOX ASSEMBLY, BK RGT .....</b>	<b>6</b>
<b>TRANSFORMER PLATE ASSEMBLY.....</b>	<b>7</b>
<b>POWER CORD BOX ASSEMBLY .....</b>	<b>7</b>
<b>TRAY CONFIGURATION .....</b>	<b>8,9</b>
<b>INNER DOOR ASSEMBLY .....</b>	<b>10,11</b>
<b>VEND PORT DOOR ASSEMBLY .....</b>	<b>12,13</b>
<b>DOOR ASSEMBLY .....</b>	<b>14,15</b>
<b>COIN INSERT/CONTROL BOARD ASSEMBLY .....</b>	<b>16,17</b>
<b>PUSH BUTTON &amp; SELECTION ASSEMBLY .....</b>	<b>18</b>
<b>MECH DOOR ASSEMBLY .....</b>	<b>19</b>
<b>REFRIGERATION CHASIS ASSEMBLY .....</b>	<b>20,21</b>

## **GENERAL INFORMATION:**

Welcome to Selectivend, Inc., we offer you three convenient ways to order replacement parts. If you have any questions when placing your order, please call and we'll be happy to assist you. Please provide the following information when placing your order:

Quantity Required  
Part Number  
Shipping and Billing Address  
Description  
Preferred Method of Shipment  
Vendor Model Number  
Customer Account Number  
Serial Number

- **MINIMUM ORDER \$25.00.** You may wish to inquire on prices of parts at the time of your order. If you order less than the minimum, please check our catalog for other parts you may require to bring your order up to the \$25.00 minimum order.
- **OPEN ACCOUNT** with approved credit.
- **MASTER CARD - VISA - C.O.D.**

If you have any questions, please call and we will be happy to assist you.

## **TO ORDER BY MAIL:**

You may request your requirements for parts by providing the necessary information as requested above, and mailing your order to:

Selectivend, Inc.  
P.O. Box 488  
165 North 10th Street  
Waukee, Iowa 50263-0488

If you have any questions phone or FAX us at Selectivend Parts and we will be happy to assist you. Order forms are available upon request from Selectivend, Inc. Or you may use your own purchase order form.

## **TO ORDER BY FAX MACHINE:**

**(515) 987-4447**

You may Fax your order for replacement parts by providing the necessary information as requested above to Selectivend, Inc. By using our fax, **(515) 987-4447**.

## **TO ORDER BY PHONE:**

**In US = 800-833-4411**

**In Canada = 800-858-4730**

**Outside US & Canada = 515-274-3641**

You may call in your order for replacement parts. Ask for Selectivend Parts Department. Please provide the necessary information, as requested above, to allow us to provide you with prompt courteous service. If you have any questions, so indicate and we will be happy to assist you.

## **RETURNS:**

**RESTOCKING CHARGE 20%.** A restocking charge of 20% will apply to merchandise accepted by Selectivend for return, except items processed as warranty.

All items returned must be accompanied by a "material return tag" clearly stating the reason for return. Returns are to be shipped freight prepaid to Selectivend, Inc., 165 North 10th Street, Waukee, Iowa 50263-0488. (Return tags are available upon request from Selectivend.)

If you have any questions regarding returns, please call Selectivend, Inc.

## **LIMITATION OF LIABILITY:**

Selectivend, Inc. Shall not be liable for any injury, loss or damage, whether direct, incidental or consequential arising out of the use of or the inability to use any part, parts or products sold by Selectivend, Inc. The remedies of the buyer set forth herein are exclusive, and the liability of Selectivend, Inc. With respect to any contract or sale or anything done in connection herewith, whether in connection therewith, whether in contract, in tort, under any warranty, or otherwise, shall not, except as expressly provided herein, exceed the price of the part, parts or products on which such liability is based. Any statements or representations about the parts or product, other than those contained herein, do not constitute warranties and shall not be relied on by the buyer and shall have no force of effect unless contained in a written agreement signed by officers of Selectivend.

# FINAL ASSEMBLY

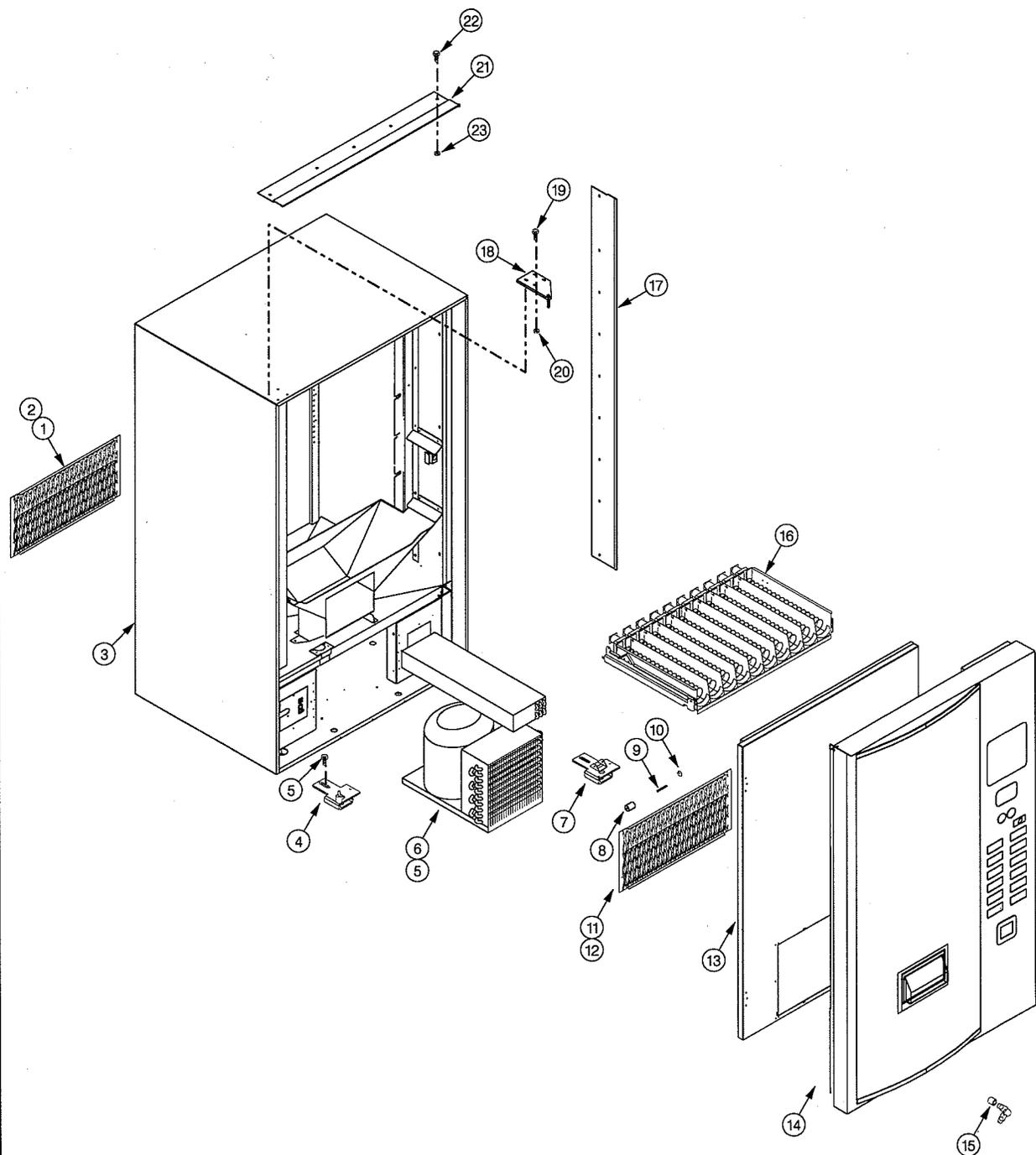

FINAL ASSEMBLY			
ITEM	PART NUMBER	QTY	DESCRIPTION
1	1212800	1	REAR SCREEN WELD
2	4050202	4	#8-18 X 1/2 PHIL HWH TEK
3	1212819	1	CABINET FINAL (SEE PAGE #5)
4	1212838	1	BOTTOM HINGE WELD
5	4050781	6	5/16-18 X 1 1/4 HH TAPTITE
6	1212766	1	REFRIGERATION SYSTEM 1/4HP (110V)
	1212766-001	1	REFRIGERATION SYSTEM 1/4HP (230V)
7	1212840	1	DOOR RISER WELD
8	8368656	1	ROLLER
9	8383009	1	PIN
10	8801077	1	RETAINING E-RING 1/4"
11	1212801	1	FRONT SCREEN WELD
12	7200468-001	2	#10-12 X 1 PHIL TH TYPE-A
13	1212822	1	INNER DOOR ASSEMBLY (SEE PAGE #11)
14	1212820	1	COMMON DOOR ASSEMBLY (SEE PAGE #15)
15	4060330	1	LOCK CYLINDER W/2 KEYS
16	1212834-XXX	6	TRAY CONFIGURATION (SEE PAGE #9)
17	4206557	1	THEFT COVER, SIDE
18	1212839	1	TOP HINGE WELD
19	4050393	4	1/4 - 20 X 3/4 CARRIAGE BOLT
20	4050547	4	1/4 - 20 TWIN WHIZ NUT
21	4206556	1	THEFT COVER, TOP
22	8354641	14	1/4 - 20 X 5/8 CARRIAGE BOLT
23	4050531	14	1/4 - 20 HEX NUT
	4206717	3	DECAL - 240V DANGER (NOT SHOWN)
	4206718	1	DECAL - EARTH GROUND (NOT SHOWN)
	4206719	2	DECAL - 2ND EARTH GROUND (NOT SHOWN)

PARTS FURNISHED IN SERVICE PACKET NOT SHOWN ON ILLUSTRATIONS IN MANUAL			
	4206656	1	SERVICE MANUAL

OPTIONAL KITS & ACCESSORIES (NOT SHOWN)			
	1212593	1	COIN BOX LOCK ASSEMBLY
	4060366	1	LOCK - COIN BOX
	4205114	1	LOCK CAM - COIN BOX
	1200137-265	1	HEATER KIT
	7202038-000	1	CUSTOM LOCK CYLINDERS (CODED TO CUSTOMER SPECS.)

# CABINET ASSEMBLY

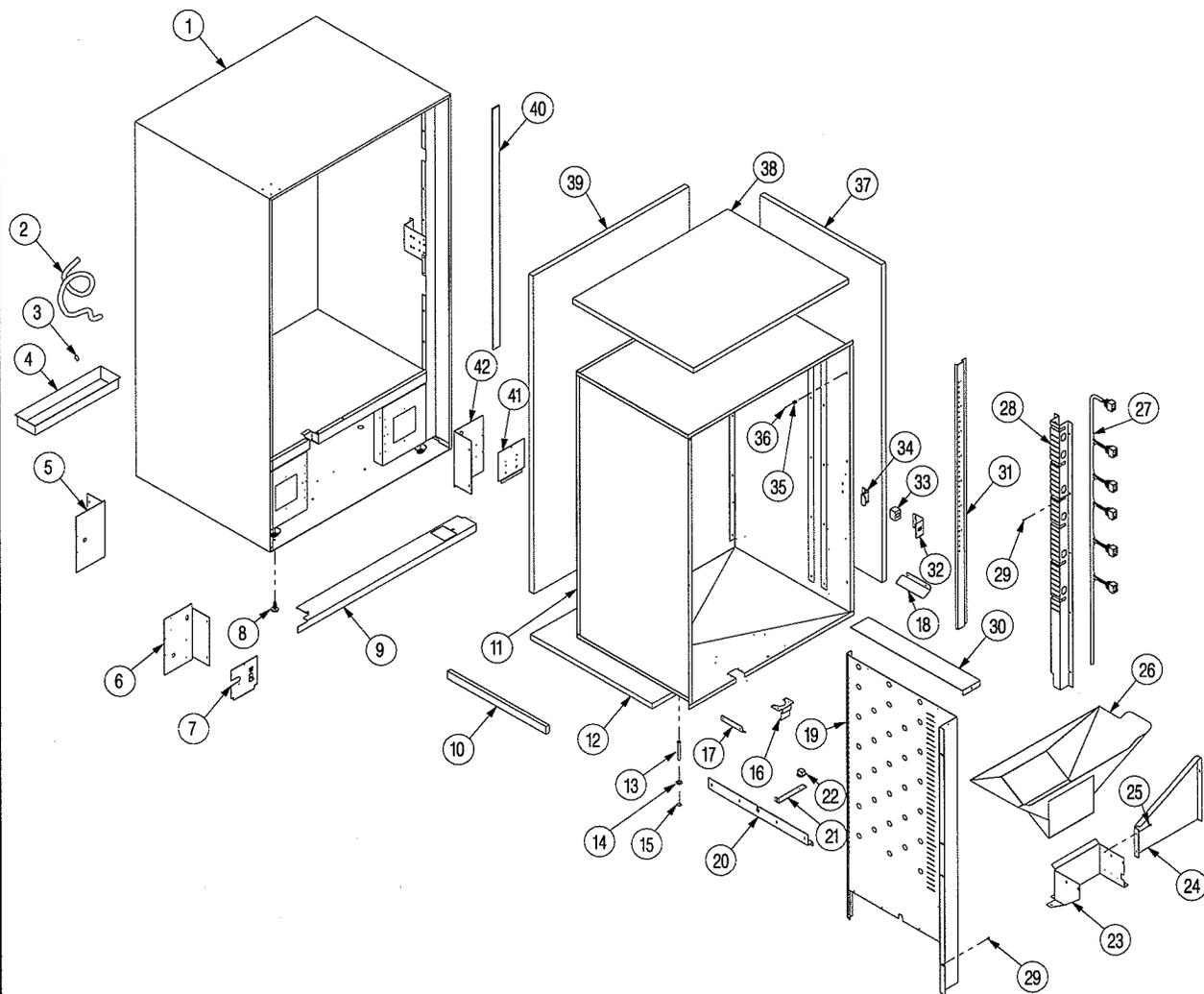

## CABINET ASSEMBLY

ITEM	PART NUMBER	QTY	DESCRIPTION
1	1212755	1	CABINET WELD
2	4025410-006	1	MAYON TUBING, 3.5 FEET
3	7200341-000	1	TUBE CLIP
4	7200623-000	1	DRAIN PAN
5	1212831-XXX	1	POWER CORD BOX ASSEMBLY (SEE PAGE #7)
6	1212828	1	ELECTRIC BOX ASSEMBLY, BACK LEFT (SEE PAGE #6)
7	1212830	1	TRANSFORMER PLATE ASSEMBLY (SEE PAGE #7)
8	4060310	4	LEG LEVELERS
9	4206644	1	COVER, LEG LEVELER
10	4202895	3	CABINET LINER SUPPORT
11	1212759	1	CABINET LINER WELD
12	4008877-003	1	INSULATION, CABINET BOTTOM
13	7100042-000	1	DRAIN TUBE
14	4050608	1	1/2 FLAT WASHER
15	4202284	1	.500 DIA PUSH NUT
16	4206402	1	SECOND FLOOR CLOSE OUT BRACKET
17	4206652	1	PRODUCT DEFLECTOR, LEFT SIDE
18	4206653	2	PRODUCT DEFLECTOR, RIGHT SIDE
19	4206435	1	SUPPORT, LEFT SIDE
20	4206486	1	EVAPORATOR RETAINER
21	4206725	1	TEMPERATURE PROBE BRACKET
22	4206782	1	TEMPERATURE SENSOR
23	4206629	1	BRACKET, HOPPER BOTTOM
24	4206628	1	BRACKET, HOPPER SIDE
25	4050180	10	#8-18 X 1/2 PHIL PH TEK
26	4206483	1	HOPPER, PLASTIC DELIVERY
27	4206677	1	CABINET HARNESS
28	4206433	1	SUPPORT, RIGHT SIDE
29	4050180	A/R	#8-18 X 1/2 PHIL PH TEK
30	4206675	1	COVER, LEFT TRAY SUPPORT
31	4206431	1	SUPPORT, BACK
32	4203487	1	LATCH NUT MOUNT
33	4203634	1	SPLIT NUT ASSEMBLY
34	4206543	1	BRACKET, LOCK BACK
35	4202189	15	SNAP-IN PLASTIC SPRING, 1/4
36	7200468-001	15	#10-12 X 1 PHIL TH TYPE-A
37	4008878-003	2	INSULATION - CABINET SIDE
38	4008881-003	1	INSULATION - CABINET TOP
39	7200952-007	1	INSULATION - CABINET BACK
40	4202278-004	1	FOAM TAPE, 2 1/4" X 16'
41	4206646	1	PLATE, RIGHT ELECTRONIC BOX
42	1212829	1	ELECTRIC BOX ASSEMBLY, BACK RIGHT (SEE PAGE #6)

A/R = AS REQUIRED

**ELECTRIC BOX ASSEMBLY, BACK LEFT**

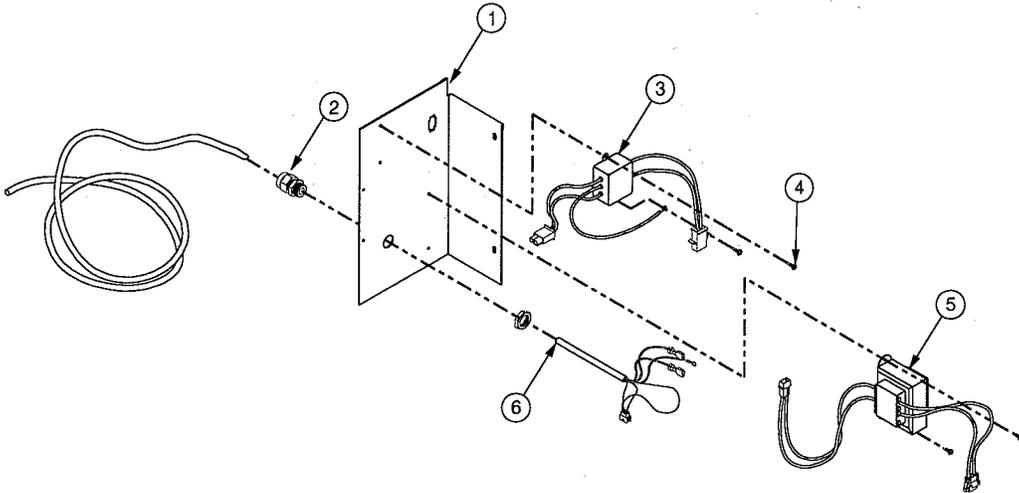

ITEM	PART NUMBER	QTY	DESCRIPTION
1	4206558	1	ELECTRIC BOX, BACK LEFT
2	4201317	1	HEYCO 3213 STRAIN RELIEF
3	4203730-002	1	R.F.I. FILTER (230V)
	4203730-003	1	R.F.I. FILTER (110V)
4	4050180	4	#8-18 X 1/2 PHIL PH TEK
5	4206570-000	1	TRANSFORMER (110V)
	4206570-001	1	TRANSFORMER (230V)
6	4206684	1	MAIN POWER HARNESS

**ELECTRIC BOX ASSEMBLY, BACK RIGHT**

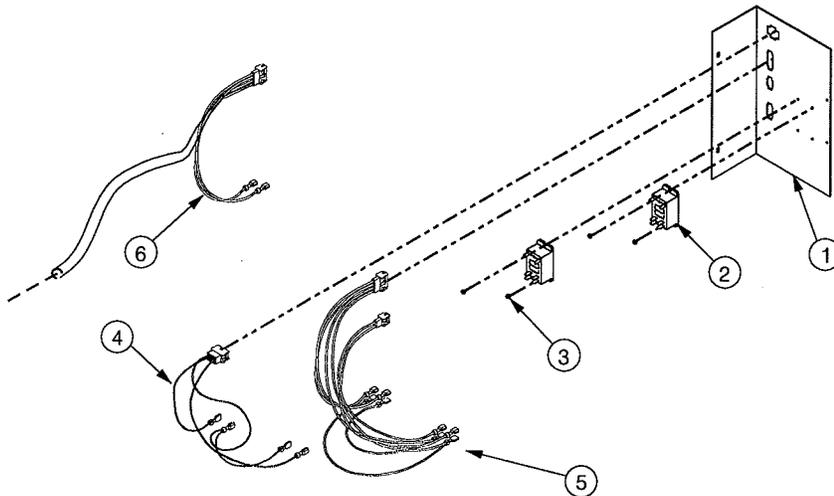

ITEM	PART NUMBER	QTY	DESCRIPTION
1	4206645	1	ELECTRIC BOX, BACK RIGHT
2	4206643	2	RELAY, 24VAC/DC30A
3	4050180	4	#8-18 X 1/2 PHIL PH TEK
4	4206681	1	RELAY HARNESS (24V)
5	4206682	1	RELAY HARNESS HIGH VOLTAGE
6	4206685	1	EVAPORATOR HARNESS

## TRANSFORMER PLATE ASSEMBLY

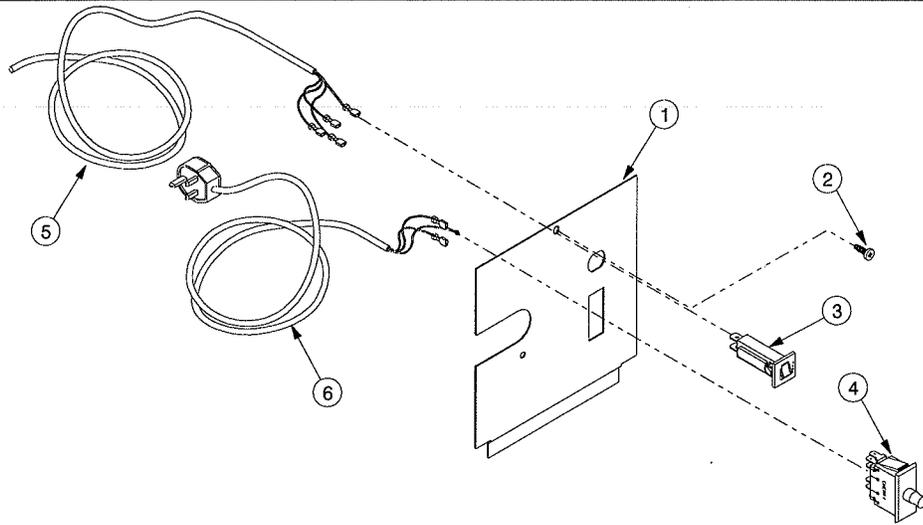

ITEM	PART NUMBER	QTY	DESCRIPTION
1	4206569	1	TRANSFORMER PLATE
2	4050180	1	#8-18 X 1/2 PHIL PH TEK
3	4203467-003	1	3 AMP CIRCUIT BREAKER
4	4206769	1	POWER DOOR SWITCH
5	4206684	1	MAIN POWER HARNESS (HI-VOLTAGE LINE)
6	4033631-005	1	POWER CORD, CANADA
	4206770-001	1	POWER CORD, ENGLISH

## POWER CORD BOX ASSEMBLY

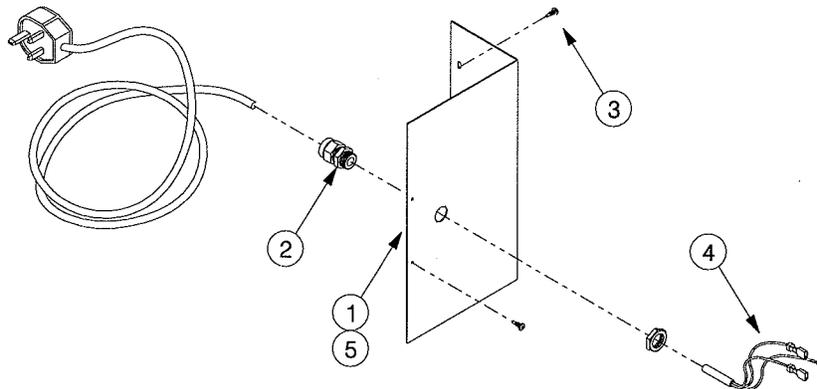

ITEM	PART NUMBER	QTY	DESCRIPTION
1	4206673	1	POWER CORD BOX
2	4201317	1	HEYCO 3213 STRAIN RELIEF
3	4050180	4	#8-18 X 1/2 PHIL PH TEK
4	4033631-005	1	POWER CORD, CANADA
	4206770-001	1	POWER CORD, ENGLISH
5	4201375	1	GROUND WARNING TAG (NOT SHOWN)

# TRAY CONFIGURATION

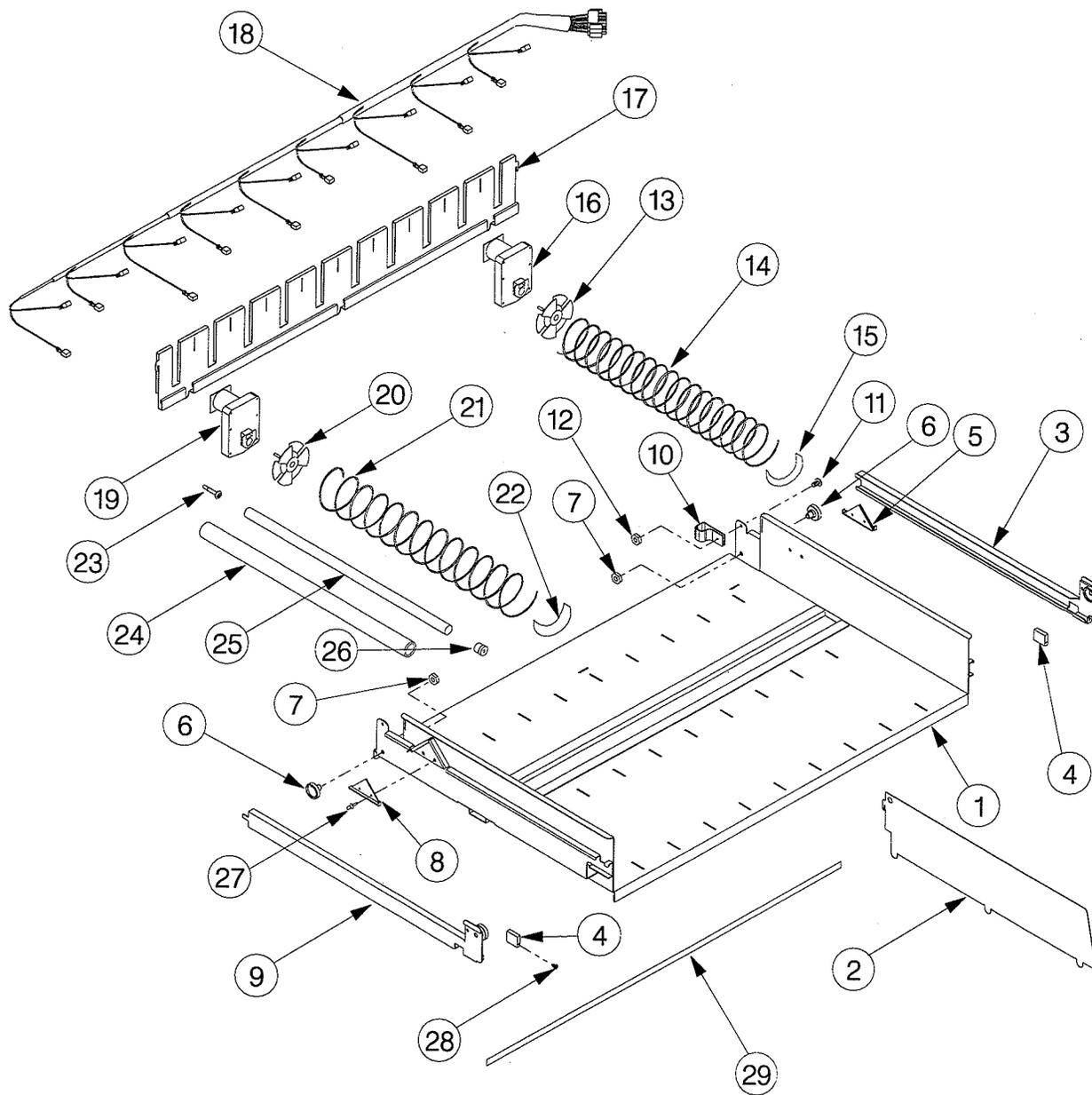

## TRAY CONFIGURATION

	1212834-XXX	1	COMPLETE TRAY
1	1212802	1	PRODUCT SHELF WELD (10 WIDE CANDY OR 5 WIDE SNACK)
	1212802-002	1	PRODUCT SHELF WELD (6 WIDE SNACK)
2	4206426	A/R	SHELF DIVIDER
3	1212837-001	1	RAIL, SLIDE ASSEMBLY, RIGHT SIDE
4	4206882	2	TRAY STOP
5	4003027-001	1	SPACER, LOAD REST, RIGHT SIDE (BOTTOM TRAY ONLY)
6	4060670-001	2	ROLLER
7	4050496	2	1/4-20 NUT TWO WAY LOCK
8	4003027-000	1	SPACER, LOAD REST, LEFT SIDE (BOTTOM TRAY ONLY)
9	1212837-002	1	RAIL, SLIDE ASSEMBLY, LEFT SIDE
10	8324099-4	1	CLAMP
11	4050244	1	#8-32 X 1/2 PHIL TH MS
12	4050513	1	#8-32 TWIN WHIZ LOCK NUT
	1212835-XXX	A/R	AUGER, ASSEMBLY (CANDY OR SNACK)
13	4202015	1	AUGER COUPLER
14	4200272-012	1	AUGER, 18 COUNT CANDY
	4200272-013	1	AUGER, 11 COUNT CANDY
	4200272-014	1	AUGER, 11 COUNT SNACK
	4200272-015	1	AUGER, 9 COUNT SNACK
	4200272-016	1	AUGER, 13 COUNT CANDY
15	4025748	1	PRODUCT EJECTOR
16	4203432-902	A/R	24VDC MOTOR, 360° (USE WITH 1212835-XXX)
17	4206429	1	SHELF BACK (10 WIDE CANDY)
	4206565	1	SHELF BACK (5 WIDE SNACK)
	4206664	1	SHELF BACK (6 WIDE SNACK)
18	4206676	1	TRAY HARNESS
19	4203432-903	A/R	24VDC MOTOR, 180° (USE WITH 1212836-013)
	1212836-013	A/R	AUGER, DUAL 13 COUNT
20	4202015	1	AUGER COUPLER
21	4202313-009	1	AUGER, 13 COUNT
22	4025748	1	PRODUCT EJECTOR
23	4200164-000	1	#8-32 X 1 1/4 SHOULDER SCREW
24	4202625-007	1	GUM& MINT HELIX TUBE
25	4202625-008	1	GUM & MINT HELIX TUBE
26	4203101	1	END CAP
27	4050667	4	1/8 X 1/4 POP RIVET (BOTTOM TRAY ONLY)
28	8800630	2	#6-20 X 1/4 PHIL PH TYPE-B
29	4206728-001	1	TRAY LABEL - A-W/SELECTIONS
	4206728-002	1	TRAY LABEL - B W/SELECTIONS
	4206728-003	1	TRAY LABEL - C-W/SELECTIONS
	4206728-004	1	TRAY LABEL - D-W/SELECTIONS
	4206728-005	1	TRAY LABEL - E-W/SELECTIONS
	4206728-006	1	TRAY LABEL - F-W/SELECTIONS
29	4206728-007	1	TRAY LABEL - A-W/O SELECTIONS
	4206728-008	1	TRAY LABEL - B W/O SELECTIONS
	4206728-009	1	TRAY LABEL - C-W/O SELECTIONS
	4206728-010	1	TRAY LABEL - D-W/O SELECTIONS
	4206728-011	1	TRAY LABEL - E-W/O SELECTIONS
	4206728-012	1	TRAY LABEL - F-W/O SELECTIONS

A/R = AS REQUIRED

# INNER DOOR ASSEMBLY

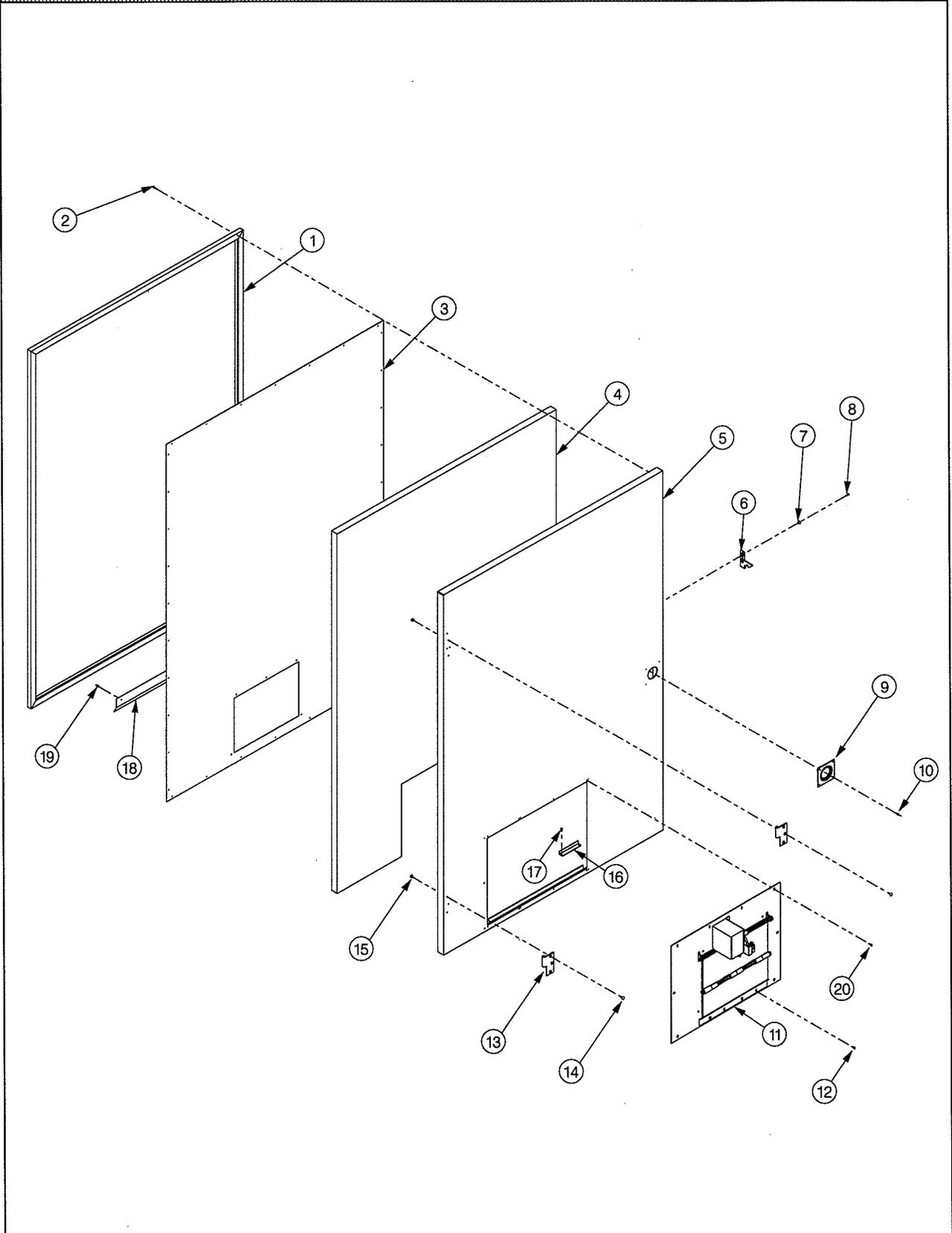

<b>INNER DOOR ASSEMBLY</b>			
<b>ITEM</b>	<b>PART NUMBER</b>	<b>QTY</b>	<b>DESCRIPTION</b>
	1212822	1	INNER DOOR ASSEMBLY
1	8620054	1	DOOR GASKET
2	4050202	38	#8-18 X 1/2 PHIL HWH TEK SCREW
3	4206466	1	INNER DOOR PANEL
4	4202868-002	1	DOOR INSULATION
5	1212804	1	INNER DOOR WELD
6	4202961	1	INNER DOOR LATCH
7	4030100	2	BUSHING SPACER
8	4050180	2	#8-18 X 1/2 PHIL PH TEK
9	4202760	1	LOCK FUNNEL
10	4050667	4	1/8 X 1/4 POP RIVET
11	1212823	1	VEND PORT DOOR ASSEMBLY (SEE PAGE # 12)
12	4050180	4	#8-18 X 1/2 PHIL PH TEK
13	8620140	2	DOOR HINGE
14	8800406	6	#10-32 X 1/2 PHIL TH W/ETW
15	8800899	6	#10-32 HEX NUT
16	4207430	1	COVER PLATE
17	4050202	2	#8-18 X 1/2 PHIL HWH TEK
18	4206654	1	PRODUCT DEFLECTOR
19	4050667	5	1/8 X 1/4 POP RIVET
20	4050423	A/R	#8-18 X 3/8 PHIL PH TY-AB

A/R = AS REQUIRED

# VEND PORT DOOR ASSEMBLY

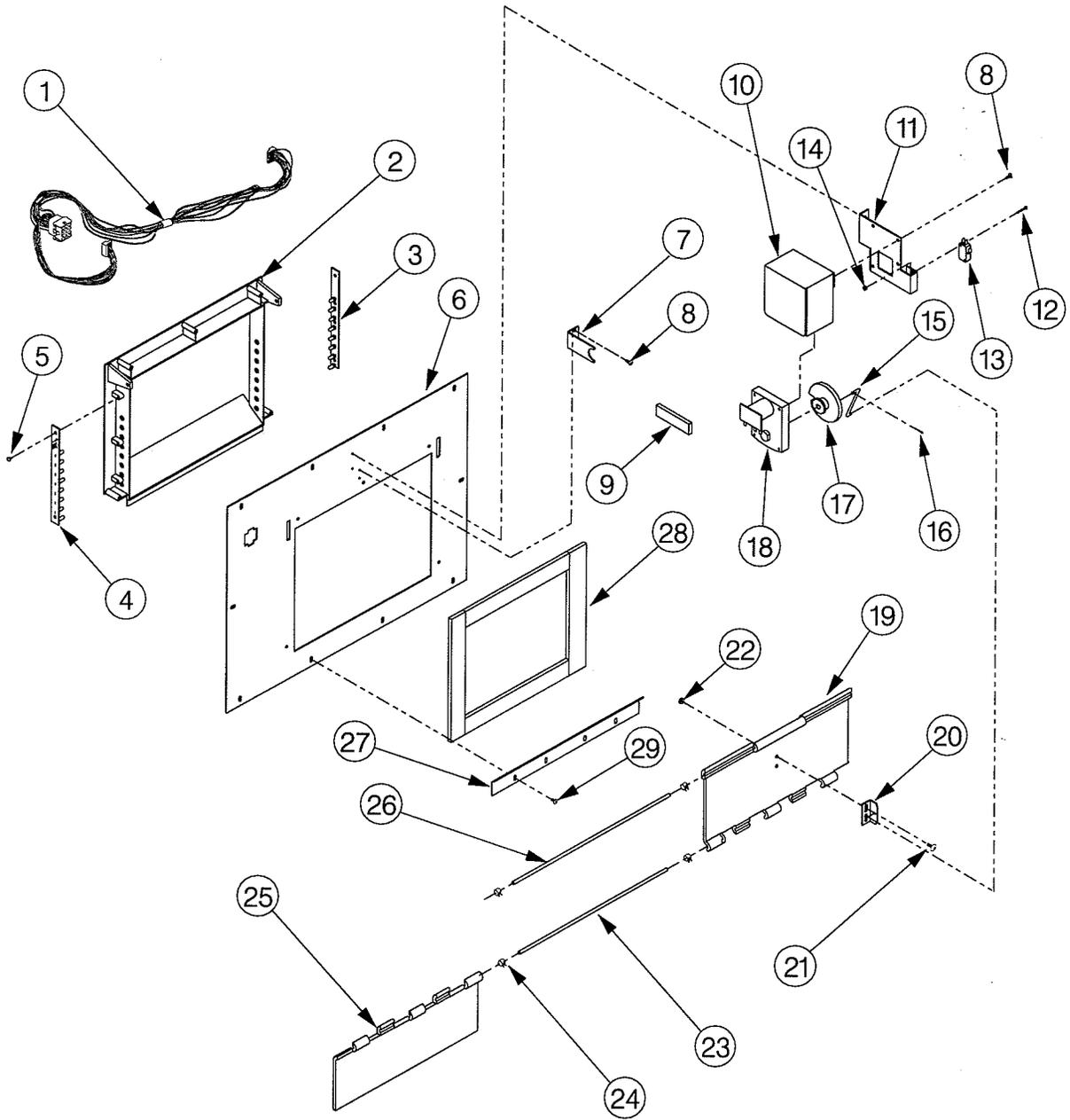

<b>VEND PORT DOOR ASSEMBLY</b>			
<b>ITEM</b>	<b>PART NUMBER</b>	<b>QTY</b>	<b>DESCRIPTION</b>
	1212823	1	VEND PORT DOOR ASSEMBLY
1	4206759	1	PHOTOCELL HARNESS
2	4206482	1	INNER DOOR BEZEL
3	4206614	1	BOARD, DELIVERY LEFT SIDE
4	4206613	1	BOARD, DELIVERY RIGHT SIDE
5	8800630	6	#6-20 X 1/4 PHIL PH TYPE-B
6	4206542	1	INNER BEZEL MOUNT
7	4206814	1	KEEPER CAM BI-FOLD DOOR
8	4050423	26	#8-18 X 3/8 PHIL PH TYPE-AB
9	4202255	.21 Ft.	GASKET 1/4 X 1/2 W/ADHESIVE
10	4206898	1	COVER, BI-FOLD DOOR MOTOR
11	4206591	1	BRACKET, INNER DOOR MOTOR
12	8801332	2	#4-40 X 3/4 PHIL PH TAPTITE
13	4033914	1	STACK SWITCH
14	8800954	2	#4-40 HEX NUT W/ETW
15	4206623	1	LINK, BI-FOLD DOOR
16	4050627	2	1/16 X 1/2 STEEL COTTER
17	4206544	1	CAM, BI-FOLD DOOR
18	4202826-900	1	24VDC MOTOR - 360°
19	4206481	1	DOOR, BI-FOLD TOP
20	4206534	1	MOUNT, BI-FOLD DOOR LINK
21	4050244	2	#8-32 X 1/2 PHIL TH MS
22	4050513	2	#8-32 TWIN WHIZ LOCK NUT
23	4206727	1	ROD, OUTER DOOR HINGE
24	7091078-000	4	TUBULAR SPEED NUT
25	4206484	1	DOOR, BI-FOLD BOTTOM
26	4206726	1	ROD, BI-FOLD DOOR HINGE
27	4206571	1	BRACKET, BI-FOLD THEFT
28	4060006-500	3.5 Ft.	1/4 X 1/2 FOAM TAPE
29	4050180	4	#8-18 X 1/2 PHIL PH TEK

# DOOR ASSEMBLY

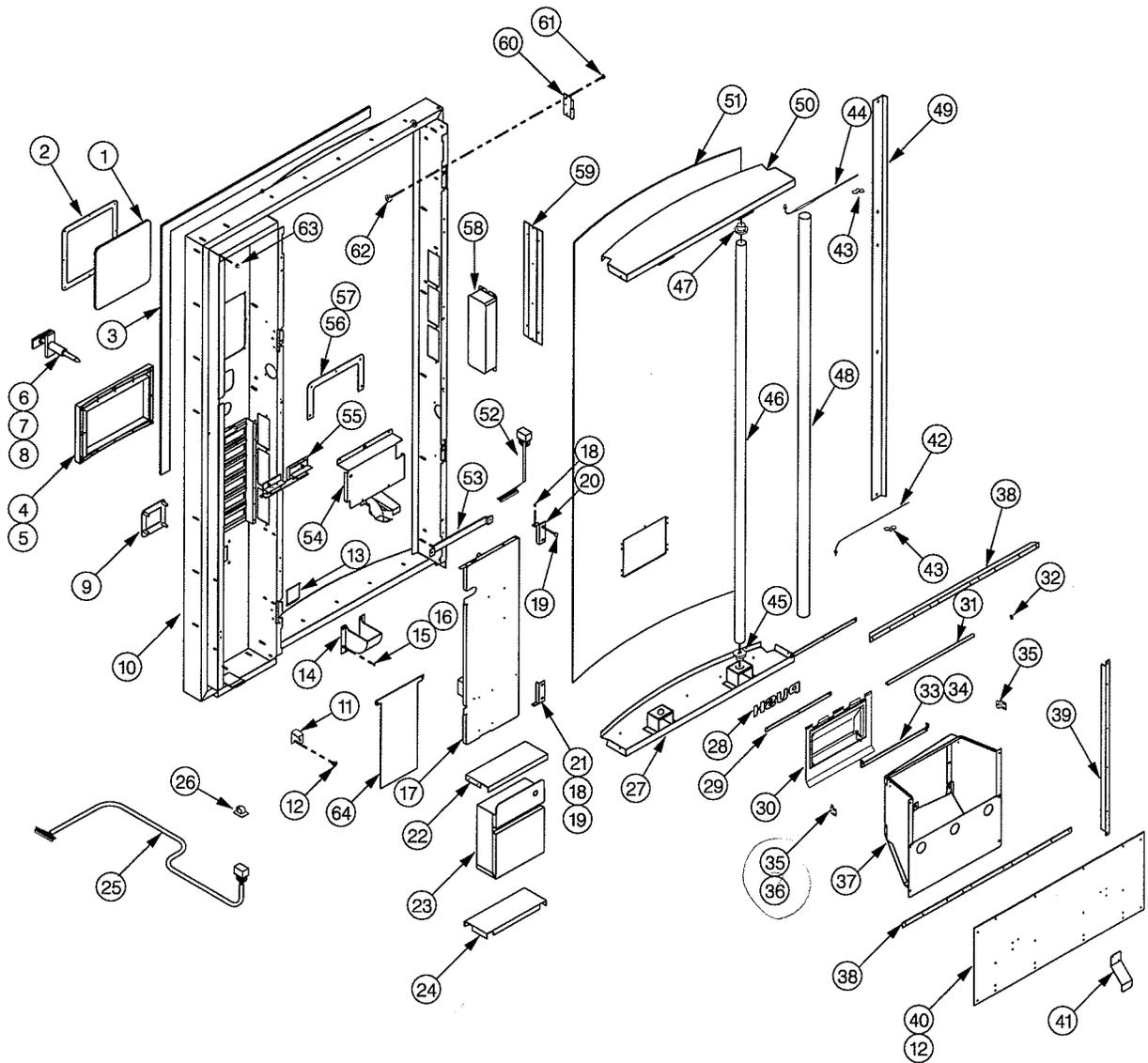

**DOOR ASSEMBLY**

ITEM	PART NUMBER	QTY	DESCRIPTION
1	4206694	1	FILLER PLATE
2	4206692	1	OUTER BEZEL
3	4202255	14.5 Ft	GASKET - 1/4 X 3/4 W/ADHV
4	4206456	1	OUTER DELIVERY BEZEL
5	8800636	6	#8-18 X 1/2 PHIL PH TYPE-B
6	4202927-XXX	1	"T" HANDLE LATCH (Specify Color when ordering)
7	7188598-000	2	#10-32 X 3/8 CARRIAGE BOLT
8	8800952	2	#10-32 HEX NUT W/ETW
9	4203209	1	COIN CUP BEZEL
10	1212805	1	DOOR WELD
11	4202908	1	INNER DOOR LIFT
12	4050180	47	#8-18 X 1/2 PHIL PH TEK
13	4203208	1	COIN CUP DOOR
14	4203207	1	COIN CUP
15	4203477	4	1/4 NUT
16	4050747	4	1/4 STAMPED HEX NUT
17	1212847	1	MECH DOOR ASSEMBLY (SEE PAGE #19)
18	8800636	2	#8-18 X 1/2 PHIL PH TYPE B
19	8800829	4	#10-24 X 3/8 PHIL TH W/ETW
20	4203476-001	1	MECH DOOR BRACKET - TOP
21	4203476	1	MECH DOOR BRACKET - BOTTOM
22	4202893	1	COIN BOX BRACKET - TOP
23	1212009	1	COIN BOX WELD - TALL
24	4205126	1	COIN BOX BRACKET - BOTTOM
25	4206722	1	DOOR HARNESS
26	4060134	3	PLASTIC WIRE CLAMP 1"
27	1212846	1	INNER DISPLAY BRACKET WELD - BOTTOM
28	4206738	1	DECAL - PUSH
29	4206900	1	DELIVERY DOOR RETAINER
30	4206452	1	OUTER DELIVERY DOOR
31	4206727	1	ROD, DOOR
32	8360470	3	SPRING, .250 X 3/4
33	4206899	1	DELIVERY DOOR RETAINER
34	4207009	3	RIVET, 1/4 - 3/8 X 5/32
35	4206576	2	PLATE HINGE ADJUSTER
36	4050212	4	8-32 X 1/4 PHIL PH TYPE-T
37	1212803	1	DELIVERY CHUTE WELD
38	4202917	2	TIE BRACKET
39	4206577	2	DELIVERY MOUNT BRACKET
40	4206729	1	COVER, DOOR BOTTOM
41	4207383	1	POWER SWITCH ACTIVATOR
42	4206721	1	LOWER LAMP HARNESS
43	4060130	5	PRESS CLIP 1/4
44	4206720	1	UPPER LAMP HARNESS
45	4202881-002	2	LAMPHOLDER - BOTTOM
46	4202751	2	LAMP - F64 T12/CW
47	4202881-001	2	LAMPHOLDER TOP
48	4205993	2	LAMP SAFETY SHIELD
49	4203685	2	PLASTIC HOLDER
50	1212845	1	INNER DISPLAY BRACKET WELD - TOP
51	4206457	1	GRAPHICS SIGN FACE (230V)
	4206457-001	1	GRAPHICS SIGN FACE (110V)
52	4206724	1	COIN MECH HARNESS
53	4207004	1	PANEL SPACER
54		1	COIN INSERT/CONTROL BOARD ASSEMBLY (SEE PAGE #17)
55		1	PUSH BUTTON/SWITCH ASSEMBLY (SEE PAGE #18)
56	4206693	1	INNER BEZEL
57	8800956	9	#8-32 HEX NUT W/ETW
58	1212875	1	BALLAST (230V)
	1212875-001	1	BALLAST (110V)
59	4206736	1	PLATE, BALLAST MOUNT (230V)
	4206901	1	PLATE, BALLAST MOUNT (110V)
60	8620139	2	INNER DOOR HINGE
61	8800406	6	#10-32 X 1/2 PHIL TH W/ETW
62	8800899	6	#10-32 HEX NUT
63	4202994	2	BUMPER
64	4206960	1	COIN MECH. SHIELD
	4033712	10	CABLE TIE 7 3/8" (NOT SHOWN)

# COIN INSERT/CONTROL BOARD ASSEMBLY

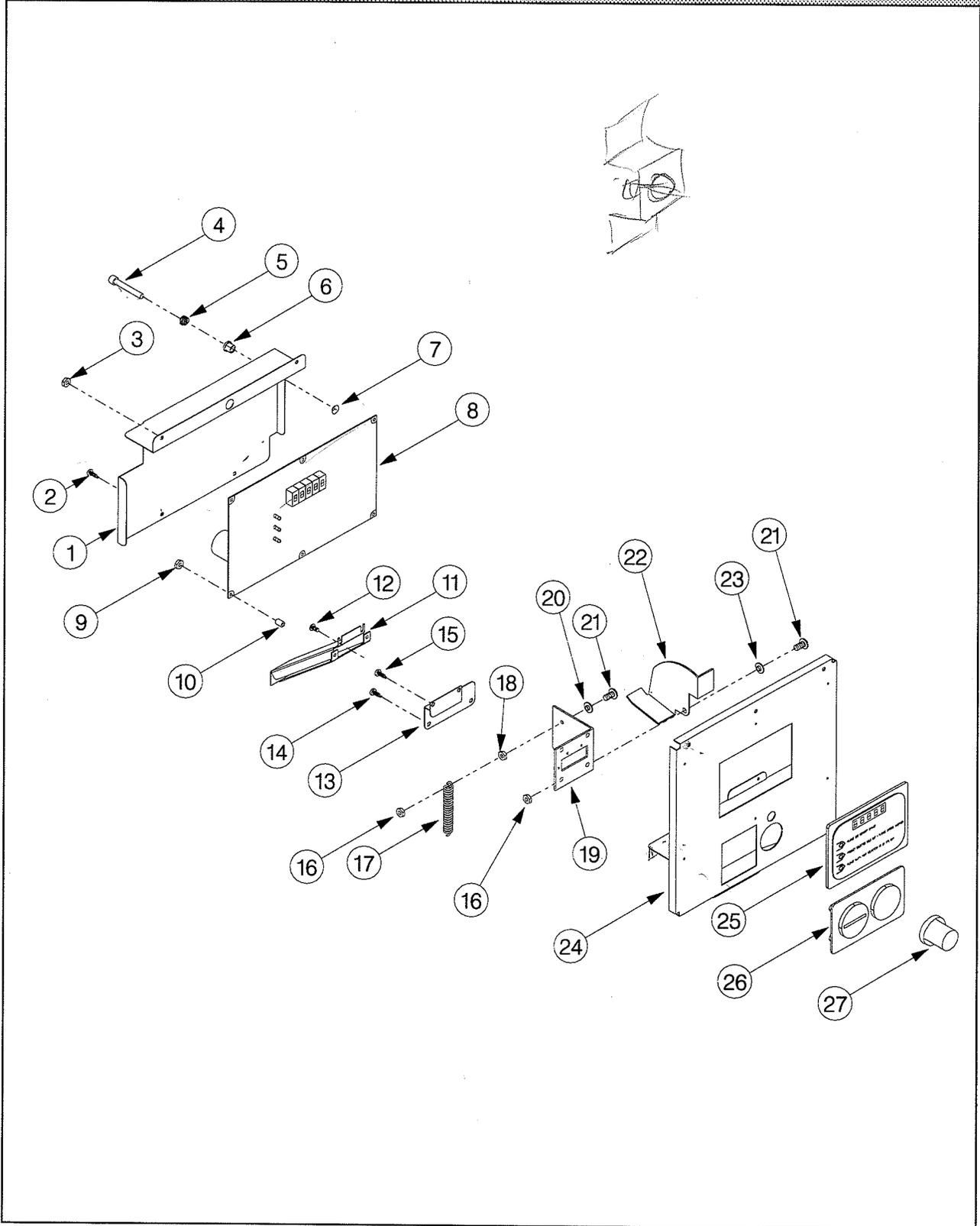

**COIN INSERT/CONTROL BOARD ASSEMBLY**

ITEM	PART NUMBER	QTY	DESCRIPTION
1	4206672	1	MAIN PC BOARD GUARD
2	4050180	2	#8-18 X 1/2 PHIL PH TEK
3	8800956	2	#8-32 HEX NUT W/ETW
4	4203144	1	MODE BUTTON
5	4021017	1	SPRING
6	4203181	1	1/4 ID SNAP BUSHING
7	4203477	1	1/4 NUT
8	4206535	1	MAIN PC BOARD
9	8800954	6	4-40 HEX NUT W/ETW
10	4206767	6	STANDOFF
11	1212861	1	COIN CHUTE WELD, (230V)
	1212880	1	COIN CHUTE WELD, (110V)
12	7200468-005	4	#6-18 X 1/4 PHIL TYPE A
13	4207005	1	READOUT BRACE
14	4050180	2	#8-18 X 1/2 PHIL PH TEK
15	4050423	3	#8-18 X 3/8 PHIL PH TYPE-AB
16	4050494	2	#8-32 NUT
17	8360471	1	SPRING EXT 2-30 COILS
18	4050513	1	#8-32 TWIN WHIZ LOCK NUT
19	4206581	1	COIN RETURN LEVER BRACKET
20	4030053	1	SHOULDER SPACER
21	4050262	2	8-32 X 3/4 PHIL PH
22	4206582	1	COIN RETURN LEVER
23	4030100	1	BUSHING, SPACER
24	1212862	1	READOUT WINDOW WELD
25	4206474	1	READOUT WINDOW
26	4203186-028	1	COIN INSERT
27	4203187	1	PUSHBUTTON

## PUSH BUTTON & SELECTION ASSEMBLY

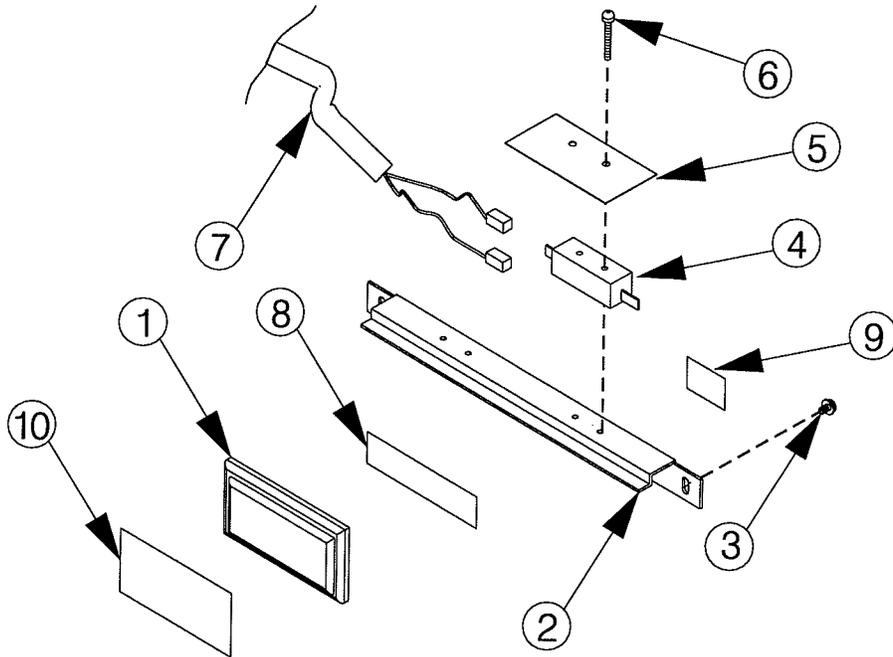

ITEM	PART NUMBER	QTY	DESCRIPTION
1	1211441	12	PUSH BUTTON ASSEMBLY
2	4203293	6	SWITCH BRACKET
3	4050420	12	#8-18 X 1/4 PHIL HWH TEK
4	4203325	12	SWITCH
5	4203324	12	SWITCH SPRING
6	8801390	24	#6-32 X 1 PHIL PH TAPTITE
7	4206723	1	SELECTION HARNESS
8	4202255	3 FT	1/4 X 3/4 GASKET W/ADHESIVE
9	8620438	1	LABEL - DOUBLE DIGIT #S
10		-	FLAVOR TAB (CONTACT DISTRIBUTOR)

## MECH DOOR ASSEMBLY

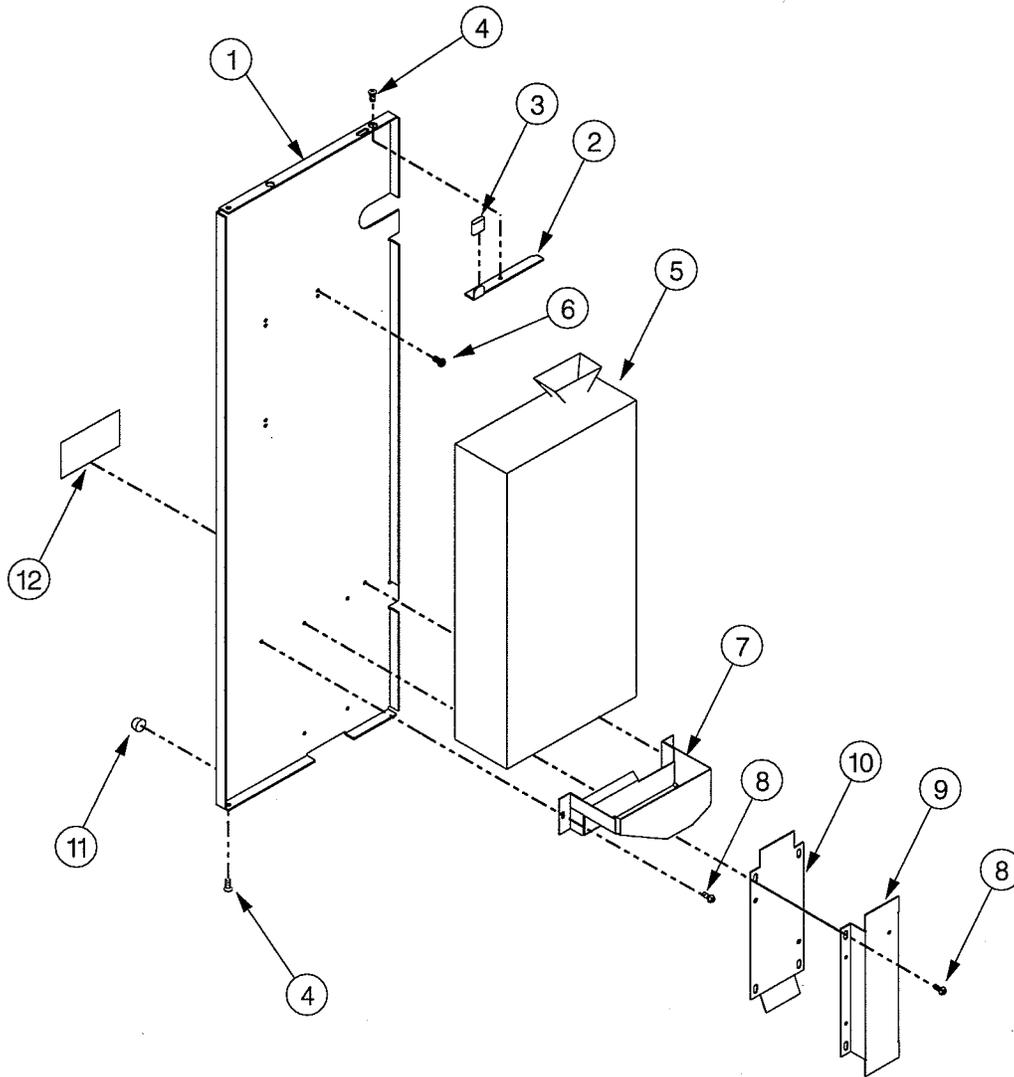

ITEM	PART NUMBER	QTY	DESCRIPTION
	1212847	1	MECH DOOR ASSEMBLY
1	4206657	1	MECH DOOR (Specify Color)
2	4202897	1	MECH DOOR LATCH
3	8620828	1	4 PIN COVER
4	8800636	3	#8-18 X 1/2 PHIL PH TYPE B
5	4206699-001	1	COIN MECHANISM - GREAT BRITAIN
6	8800498	3	#8-18 X 3/8 PHIL PH TYPE B
7	1212812	1	COIN RETURN WELD
8	4050420	6	#8-18 X 1/4 PHIL HWH SCREW
9	4202901	1	COIN KICKER
10	4202888	1	COIN BOX TUBE
11	4202994	2	BUMPER
12	8620711	1	POWER SWITCH WARNING LABEL

# REFRIGERATION CHASSIS ASSEMBLY

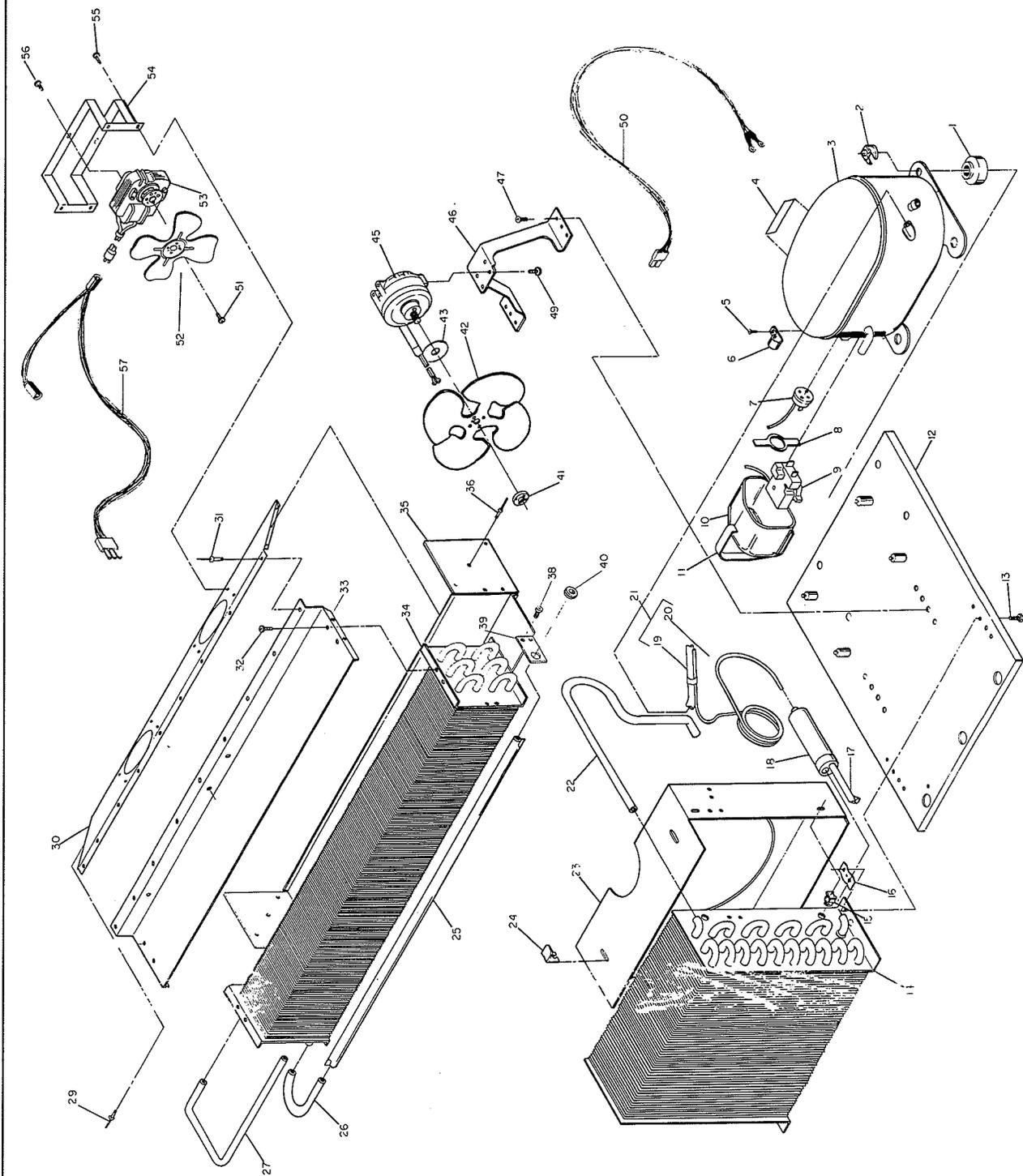

## REFRIGERATION CHASSIS ASSEMBLY

ITEM	PART NO.	QTY	DESCRIPTION
	1212766	1	REFRIG SYSTEM 1/4 HP, 110V
	1212766-001	1	REFRIG SYSTEM 1/4HP, 230V
1	8323090-1	4	GROMMET-COMPRESSOR
2	8343874	4	SPRING CLIP
3	4203789	1	COMPRESSOR - 1/4HP - 110V-134a
	4205469	1	COMPRESSOR - 1/4HP - 230V-134a
4	7332492-000	1	DECAL WARNG WARRANTY
5	7310059-000	1	#10-16X3/8 PHIL TH TY-B
6	7332446-000	1	CLAMP-SUCTION LINE
7	8045052-12	1	OVERLOAD PROTECTOR - 110V
	8045052-16	1	OVERLOAD PROTECTOR - 230V
8	8344305	1	SPRING-OVERLOAD
9	8333894-8	1	RELAY-STARTING - 110V
	8333894-10	1	RELAY-STARTING - 230V
10	8344308	1	COVER-TERMINAL
11	8344306	1	BALE STRAP
12	8343839	1	BASE PLATE REFRIG
13	7332393-000	4	1/4-20X3/8 SLTD HH MS
14	7332338-000	1	CONDENSER COIL-1/3 HP
15	4205214	4	CHRISTMAS TREE CLIP
16	8916923	2	1/4-20 TWIN SPRNG NUT
17	7187215-000	1	DISC LINE 1/4ODX2 3/8
18	4205468	1	DRIER-BONDED CORE
19	8801181-004	1	5/16X.032X5 CU TUBING
20	8902701-2	1	CAPILLARY TUBE
21	1212768	1	SUCTION LINE ASSY
22	7332437-000	1	DISCHARGE TUBE
23	7332405-000	1	SHROUD-CONDENSER
24	8336640	2	RETAINING CLIP
25	7332073-000	1	ACCUMULATOR
26	7332422-000	1	TUBE-ACCUMULATOR CONN
27	7332423-000	1	TUBE-CAPILLARY CONN
29	4050663	5	RIVET
30	4206487	1	EVAP FAN SHROUD
31	4050663	7	RIVET
32	8801204	4	#10-16X3/8 PHIL TH W/ETW
33	7332357-000	1	TOP BAFFLE-EVAPORATOR

ITEM	PART NO.	QTY	DESCRIPTION
34	7332400-000	1	COIL EVAPORATOR
35	4206488	1	EVAP BAFFLE
36	4050663	5	RIVET
38	8801204	2	#10-16X3/8 PHIL TH W/ETW
39	7332384-000	1	BRACKET-ACCUMULATOR
40	4034157	1	GROMMET-SPLIT 1/2
41	7186097-000	1	1/4-20 RD SPRING NUT
42	7332420-000	1	FAN BLD 8 3/4X26 DEG
43	7187394-000	1	SILENCER-CNDSR
45	7332418-000	1	MOTOR-5 W COND FAN 110 V
45	7332418-001	1	MOTOR-5 W COND FAN 230 V
46	8358154-001	1	FAN SUPPORT
47	8800721	2	1/4-20X1/2 HH-LW TYPE-D
49	7186154-000	4	#8-36X3/8 PHIL PH
50	4206760	1	EVAPORATOR HARNESS

NOTE: FOR ITEMS 51- 56 CHECK MANUFACTURER OF MOTOR BEFORE ORDERING

HOWARD MOTOR			
	7331298-001	2	EVAPORATOR FAN ASSY
51	7186811-000	2	#3-48 X 3/16 RD HD MS
52	7186825-000	1	FAN BLADE CCW-ALUM
53	7331297-000	1	FAN MOTOR - 4 1/2 WATT - 110 V
	7250309-000	1	FAN MOTOR - 4 1/2 WATT - 230 V
54	7330391-000	1	MOTOR MOUNT
55	4050423	8	#8-18X3/8 PHIL PH TY-AB
56	8800679	2	#10-32X5/16 PHL PH W/ETW
FASCO MOTOR			
		2	EVAPORATOR FAN ASSY
51	8800679	2	#10-32 X 5/16 PHIL PH W/ETW
52	4205768-001	1	FAN BLADE CCW-ALUM FASCO
53	4206461	1	FAN MOTOR - 4 1/2 WATT - 110 V
	4206461-001	1	FAN MOTOR - 4 1/2 WATT - 230 V
54	7330391-000	1	MOTOR MOUNT
55	4050423	8	#8-18X3/8 PHIL PH TY-AB
56	8800679	2	#10-32X5/16 PHL PH W/ETW

57	4206761	1	COMPRESSOR HARNESS
	4033712	8	CABLE TIE 7 3/8" (Not Shown)

