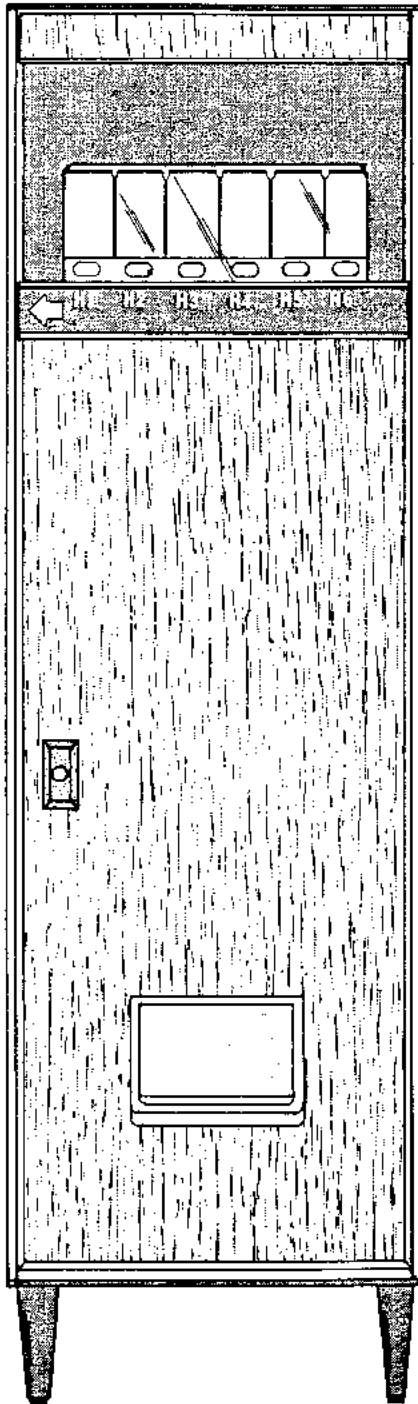


# CAN DRINK MERCHANDISER

MODEL 3016

*CAN MART*

---



## SERVICE MANUAL

FEBRUARY, 1990  
REVISION (A)

P/N 4201539

# TABLE OF CONTENTS

<b>INTRODUCTION</b> .....	1
<b>SPECIFICATIONS</b> .....	1
<b>UNPACKING</b> .....	2
<b>INSTALLATION</b> .....	3-4
<b>LOOSE PARTS</b> .....	3
<b>GROUNDING &amp; ELECTRICAL</b> .....	3
<b>INSTALLATION INSTRUCTIONS</b> .....	4
<b>LOADING INSTRUCTIONS</b> .....	5
<b>PRODUCT DISPLAY AREA</b> .....	5
<b>PRICE SETTING INSTRUCTIONS</b> .....	6
<b>PRICE SETTING SEQUENCE</b> .....	7
<b>COPY PRICE MODE INSTRUCTIONS</b> .....	8
<b>VERIFYING VEND PRICES</b> .....	8
<b>COPY PRICE MODE SEQUENCE</b> .....	9
<b>FUNCTIONS AND COMPONENTS</b> .....	10-14
<b>CABINET HEATER WIRE</b> .....	10
<b>LIGHT ASSEMBLY</b> .....	10
<b>UPPER AND LOWER EJECTORS</b> .....	10-11
Vend Motor.....	10
Large Cam.....	10
Small Cam.....	11
Spacer.....	11
Override Switch.....	11
Motor Switch.....	11
Sold-out Switch.....	11
<b>UPPER EJECTOR MECHANISM REMOVAL</b> .....	11-12
<b>RE-INSTALLING UPPER EJECTOR MECHANISM</b> .....	12
<b>LOWER EJECTOR MECHANISM REMOVAL</b> .....	12-13
<b>RE-INSTALLING LOWER EJECTOR MECHANISM</b> .....	13
<b>10-OUNCE CONVERSION</b> .....	14
<b>REFRIGERATION SYSTEM</b> .....	15-18
<b>COMPRESSOR</b> .....	15-16
Power Supply.....	15
Starting Relay.....	15
Overload Protector.....	15
Cold Control.....	15
Evaporator Fans.....	16
Condenser Fans.....	16
<b>REFRIGERATION SYSTEM REMOVAL</b> .....	16-17
<b>EVAPORATOR FAN REMOVAL</b> .....	17
<b>CONDENSOR FAN BLADE OR MOTOR REMOVAL</b> .....	18
<b>REFRIGERATION SYSTEM TROUBLE SHOOTING</b> .....	19-22
<b>COMPRESSOR WILL NOT START</b> .....	19
<b>COMPRESSOR TRIPS ON OVERLOAD</b> .....	19
<b>NOISEY OR VIBRATING UNIT</b> .....	20
<b>UNIT SHORT CYCLES</b> .....	20
<b>UNIT OPERATES LONG OR CONTINUOUSLY</b> .....	20
<b>REFRIGERATED SPACE TOO WARM</b> .....	21
<b>90% OF ALL REFRIGERATION PROBLEMS ARE ELECTRICAL</b> .....	21
<b>TROUBLE-SHOOTING UNIT CIRCUITS USING OHM-VOLT METER</b> .....	21-22
<b>CARE &amp; CLEANING</b> .....	22
<b>SCHEMATICS</b> .....	23-25
<b>WINDING RESISTANCE</b> .....	23
<b>CAN DRINK MERCHANDISER</b> .....	24
<b>GLASSFRONT MERCHANDISER</b> .....	25

The contents of this manual contains instructions, service and installation guidelines pertaining to the Can Drink Merchandiser. This will also contain various options and accessories offered within the product line.

The Can Drink Merchandiser is a six (6) select Can Vender that must be connected to a Glassfront Merchandiser (Snack Mart III Series). The Can Drink Merchandiser is a "satellite" type machine that utilizes the electronics and control systems of the Glassfront Merchandiser for all vend functions, credit accumulation, pricing and other vend-related requirements.

Money must be inserted into the "host" Glassfront Merchandiser. Selections are made at the Glassfront Merchandiser key pad and all programming is done through the Glassfront Merchandiser Controller. Connecting a Can Drink Merchandiser to the Glassfront Merchandiser electronics will allow the owner/operator to apply the same features available in the Glassfront Merchandiser to the Can Drink Merchandiser. The "software" of the Glassfront Merchandiser Controller will treat the Can Drink Merchandiser as an added shelf or tray of the Glassfront Merchandiser.

The six selections can be priced individually, with vend prices ranging from \$.05 to \$99.95 in five-cent increments. Individual vend mechanisms for each selection are designed to allow vending standard 10-ounce and 12-ounce cans. Cans are stored in "serpentine" type storage areas, easily loaded, and are routed to the 24 volt motor-driven ejector mechanisms. The ejector mechanism will consist of a "dual" cam arrangement. The front cam will hold the product to be vended at the "vend position," releasing it to the delivery area during the vend cycle. The rear cam will be advanced into the path of the cans during the vend cycle, holding them back until the vend cycle is complete. At the end of the vend cycle, the next can will be released to the "vend position."

## SPECIFICATIONS

### GENERAL SPECIFICATIONS:

Height	72 Inches
Width	21 Inches
Depth	30-5/8 Inches
Weight	430 Pounds

### ELECTRICAL:

Power Requirement	115 VAC 60 Hz
Starting Amps	10 Amps
Running Amps	6 Amps

### CAPACITY:

Selections	6 Select
Cans in Vend Area	204 12-oz.
Cans Pre-Cooled	18 12-oz.

### PRICING:

6 Prices	\$.05 to \$99.95
----------	------------------

### COINAGE:

Shared with "host" unit

### REFRIGERATION:

Unit size	1/4 HP.
-----------	---------

# UNPACKING

This machine has been thoroughly inspected before leaving the factory and the delivering carrier has accepted this vendor as their responsibility. Any damage or irregularities should be noted at the time of delivery and reported to the carrier. Request a written inspection report from the claims inspector to file any claim for damage. File the claim with the CARRIER (**NOT THE MANUFACTURER**) within 15 days after receipt of the machine.

Record the model number and serial number of the vendor for your records. These numbers can be found on the serial plate located on the rear of the cabinet. Refer to these numbers on all correspondence and inquiries pertaining to this vendor.

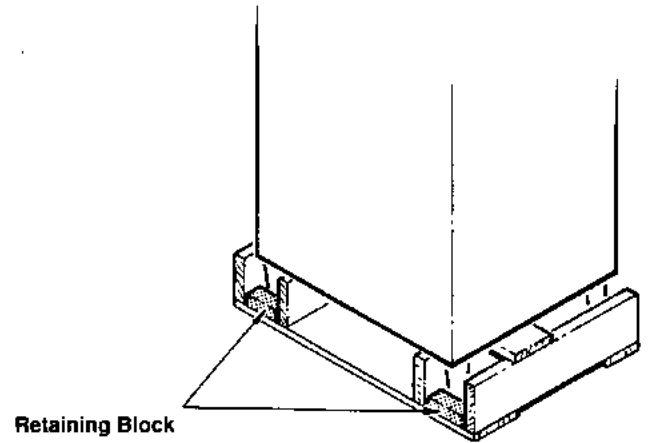
To minimize installation time and to avoid service problems due to improper installation, follow the instructions outlined in this manual.

Carefully remove the shipping carton in a manner not to damage the finish or exterior of the machine. Inspect the machine for concealed shipping damage. Report any damage hidden by the shipping carton directly to the delivering carrier on a "hidden damage" report.

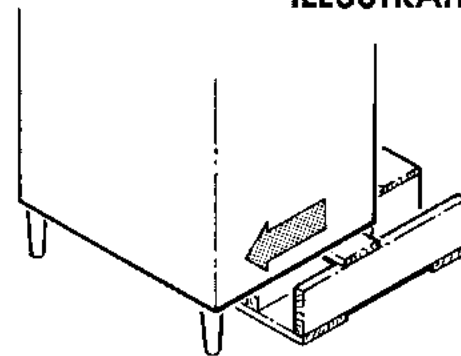
Remove the two (2) retaining blocks from the shipping pallet (See **Illustration #1**). Slide the vendor sideways on the shipping pallet until the side legs are clear of the pallet. Tilt the machine sideways until the rear legs are clear of the pallet and remove the pallet.

Position the vendor to the right of the Glassfront Merchandiser. Leave at least six (6) inches of space between the back of the Can Drink Merchandiser and any wall or obstruction for proper air circulation. Level the vendor making sure all levelers are touching the floor.

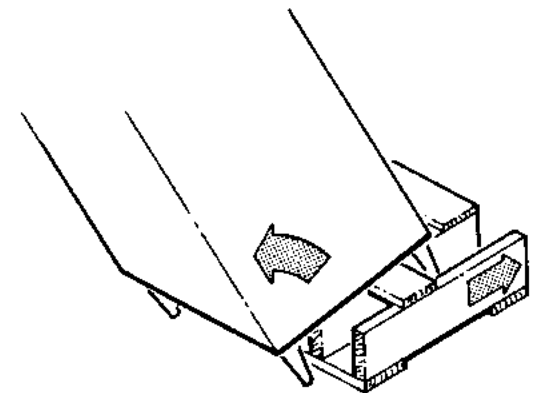
**NOTE:** If both a Cold Food merchandiser and a Can Drink Merchandiser are to be connected to a Glassfront Merchandiser, the Can Drink Merchandiser should be positioned to the left of the "host" machine.



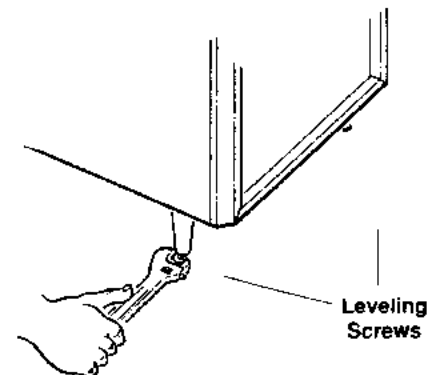
**ILLUSTRATION #1A**



**ILLUSTRATION #1B**



**ILLUSTRATION #1C**



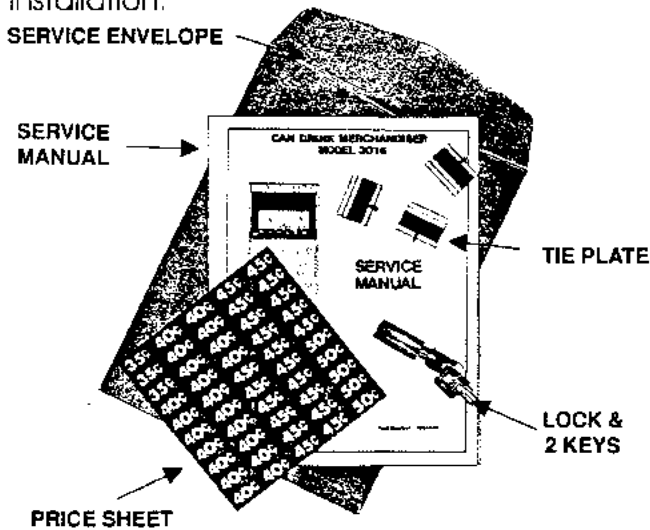
**ILLUSTRATION #1D**

# INSTALLATION

THE CAN DRINK MERCHANDISER MUST BE CONNECTED TO A GLASSFRONT MERCHANDISER. THE STEPS OUTLINED ON THE FOLLOWING PAGES ARE THE BASIC INSTRUCTIONS

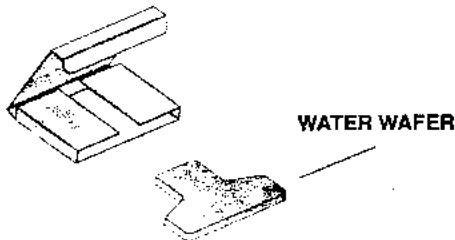
FOR INSTALLING THE CAN DRINK MERCHANDISER. REFER TO THESE INSTRUCTIONS ALONG WITH THE WIRING DIAGRAMS DURING INSTALLATION.

A loose parts box and service packet will contain the following parts necessary for this installation.



PART-NUMBER	QTY.	PART DESCRIPTION
4020697	1	SERVICE ENVELOPE
1210809	3	TIE PLATE ASSY.
* 4060330	1	LOCK & 2 KEYS
4201539	1	SERVICE MANUAL
4200052	1	PRICE SHEET

\* Available less lock & keys



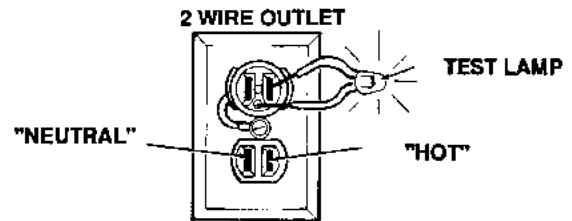
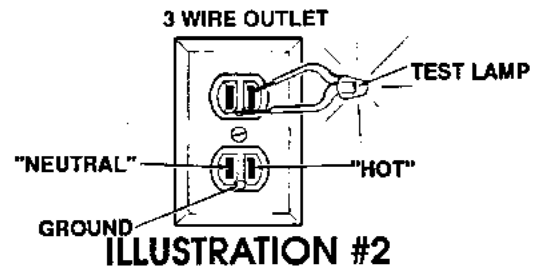
PART-NUMBER	QTY.	PART DESCRIPTION
4060045	1	WATER WAFER

## GROUNDING & ELECTRICAL

Consult local, state and federal codes and regulations before installation of the vendor.

For proper operation of any equipment

utilizing electronic-controlled components, it is recommended that the equipment be placed on an isolated or individual circuit. The circuit should be a minimum 15 Amp, 115 Volt AC, 60 Hz, properly polarized and grounded. Shown in **Illustrations #2** and **#3** are two (2) properly-grounded and polarized wall outlets. **Illustration #2** is a three (3) wire grounding type wall outlet. **Illustration #3** is a two (2) wire outlet with a three (3) plug adaptor in place.



**ILLUSTRATION #3**

To verify that the receptacle is properly grounded and polarized, insert one probe of a volt-ohm meter (set to check AC line voltage) or a neon test light in the ground terminal (hole) and the other probe into the "hot" terminal of the outlet. You should read 115 VAC on the volt-meter or the test light should light.

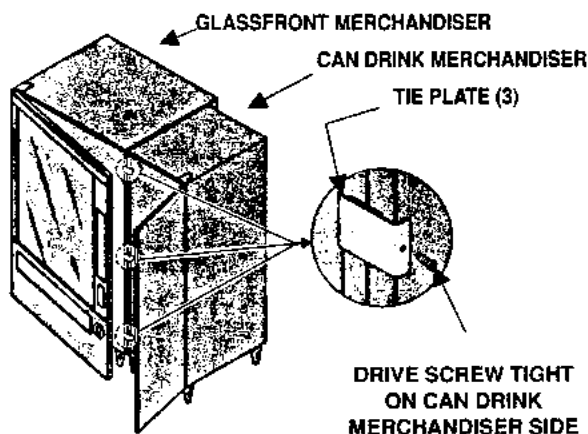
**NOTE:** The "hot" side of the outlet should always be counter-clockwise from the grounded terminal, with the ground terminal at the bottom.

If you find that the receptacle is not grounded, or polarized, you should contact a licensed electrician to correctly polarize and/or ground the receptacle to ensure safe operation.

# INSTALLATION CONTINUED

## INSTALLATION INSTRUCTIONS

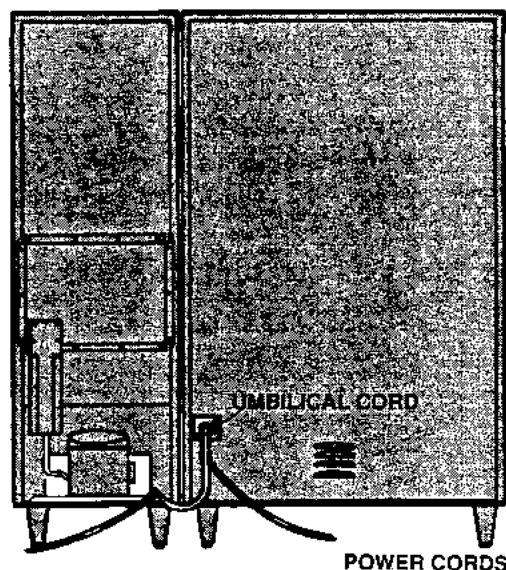
1. Unpack the Can Drink Merchandiser in a manner not to damage the finish or the exterior of the machine. Inspect for concealed shipping damage. Report any damage hidden by the shipping carton directly to the carrier.
2. Set and level the Can Drink Merchandiser to the right of the Glassfront Merchandiser "host machine" and connect the machines together with three (3) "tie plates" furnished in the Loose Parts Package. See **Illustration #4** below for connecting the machines together.



**ILLUSTRATION #4**

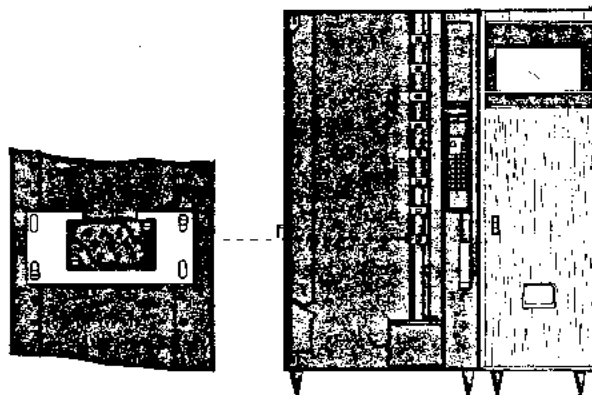
**NOTE:** If both a Cold Food Merchandiser and a Can Drink Merchandiser are being connected to the Glassfront Merchandiser, the Can Drink Merchandiser should be positioned to the left of the Glassfront Merchandiser.

3. Unplug the Glassfront Merchandiser from the power supply.
4. Remove the plate from the back of the Glassfront Merchandiser cabinet and insert the "umbilical" cord from the Can Drink Merchandiser through the hole in the back of the Glassfront Merchandiser and attach the plate (furnished on the cord) using the removed hardware. (See **Illustration #5**)



**ILLUSTRATION #5**

5. Connect the "umbilical" cord from the Can Drink Merchandiser to the Glassfront Merchandiser main cabinet harness (connection "H") located in the lower compartment of the Glassfront Merchandiser cabinet. (See **Illustration #6**)



**ILLUSTRATION #6**

6. Plug both the Glassfront Merchandiser and Can Drink Merchandiser into the building power source.
7. Set prices for the Can Drink Merchandiser selections (refer to the **Price Setting Instructions**) and test vend both machines for proper operation.

Refer to **Wiring Diagrams** on both the Can Drink Merchandiser and Glassfront Merchandiser (in back of manual) for proper identification of the connections and components.

# LOADING INSTRUCTIONS

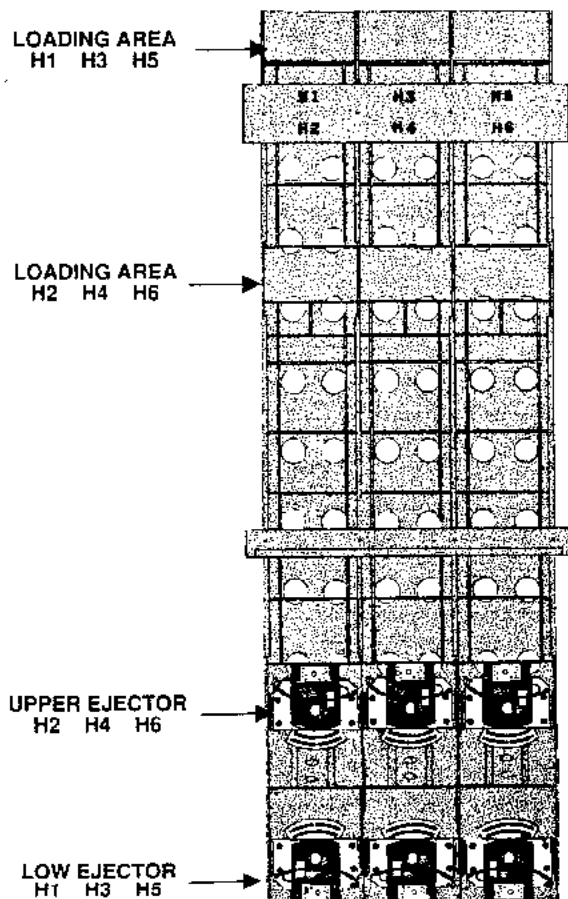
## LOADING INSTRUCTIONS

There are six (6) 12-ounce selections in the vendor, and a pre-cool area for eighteen (18) 12-ounce cans.

The selections are numbered from top to bottom, left to right when facing the vendor. Selections numbered one (1), three (3) and five (5) will hold 33 cans each. Selections numbered two (2), four (4) and six (6) will hold 35 cans each.

**NOTE:** When loading the columns, do not let first cans loaded strike the motor cams with full force.

When loading the columns, place the cans into the proper opening. Lay the cans on their side and allow them to roll down the serpentine column to the ejector mechanism. Keep placing cans into the column until the serpentine column is full to the top opening. (See **Illustration #7**)

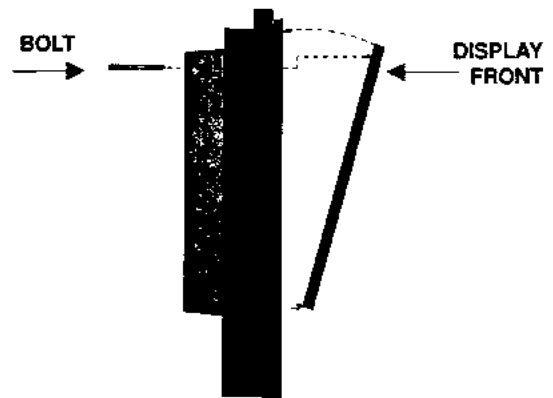


**ILLUSTRATION #7**

## PRODUCT DISPLAY AREA

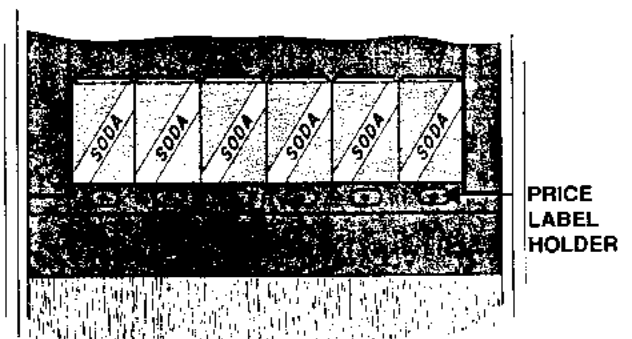
The live display will provide a full view of the products being dispensed and a label holder to indicate the vend price set for each selection. The serpentine columns and displays are numbered for easy identification.

To display products, loosen the bolt from the inside of the door holding the display frame into position. (See **Illustration #8**)



**ILLUSTRATION #8**

Pull out on the front of display frame. The top of the frame will tilt forward. Then pick up on the frame to remove it from the door. Position the cans to the proper number representing the selection number for that product. (See **Illustration #9**)



**ILLUSTRATION #9**

Insert a price label, found in the service package, in front of the display cans in the holder provided.

To verify the price set, depress the selection letter and number on the Glassfront Merchandiser. Watch the digital display on the Glassfront Merchandiser for the correct pricing.

# PRICE SETTING INSTRUCTIONS

## ENTERING THE PRICING MODE

All pricing and programming is done at the Glassfront Merchandiser "host machine" key pad. To set prices on the Can Drink Merchandiser selections, the Glassfront Merchandiser controller must be placed in the "Service Mode" and then advanced to the "Set Price" position.

The Can Drink Merchandiser will utilize "H1" through "H6" selections on the Glassfront Merchandiser key pad. The "software" in the Glassfront Merchandiser configures the Can Drink Merchandiser as an "eighth tray," thereby when the Can Drink Merchandiser is added the eighth tray Glassfront Merchandiser option cannot be used.

A Vend Price must be established for each selection. On items that will be vended at the same vend price, the "Copy Price" mode can be used to duplicate the prices.

To establish vend prices, follow the steps and instructions outlined below:

1. Place the Glassfront Merchandiser controller in "Service Mode." This is done by depressing the "Service Mode" switch located on the Glassfront Merchandiser control board.

**NOTE:** The Glassfront Merchandiser display will indicate any faulty selections that have been recorded by the controller at this time. These faults should be noted immediately. Refer to the "Trouble-Shooting" section of the Glassfront Merchandiser manual for additional information.

2. Enter the "Price Mode" by depressing key "5" on the front panel key pad of the Glassfront Merchandiser. (See **Illustration #10**)

- The Glassfront Merchandiser display will indicate **"MAKE SELECTION."**

3. Enter the selection number of the item to be priced using the Glassfront Merchandiser key pad.

- The selection number and current vend price will be displayed in the Glassfront Merchandiser.

4. Enter the desired vend price using the number keys on the front panel key pad.

**EXAMPLE:** If the numbers 7 and 5 were entered, that item would vend for 75 cents. (See **Illustration #10**)

5. Store the price in memory by depressing the "#" key on the front panel key pad of the Glassfront Merchandiser. The "Copy Price" mode can be used if more than one selection is to be set at the same vend price.

6. Continue setting prices for other selections by repeating **Step 3 through Step 5**.

7. After completing the price setting, depress the "Service Mode" switch located on the Glassfront Merchandiser.

The scrolling message will appear in the Glassfront Merchandiser display. The machine is now in the normal operating or "Sales Mode."

**NOTE:** Any time the Controller is placed in the "Service Mode" it will automatically return to the "Sales Mode" within 25 seconds if no input or depression of the key pad is made during this time.

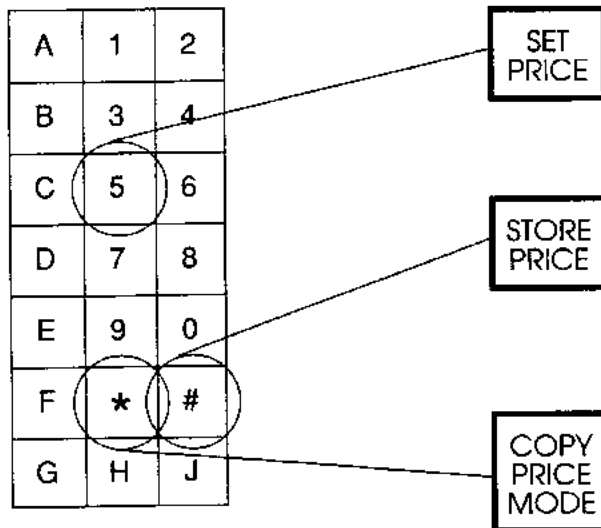
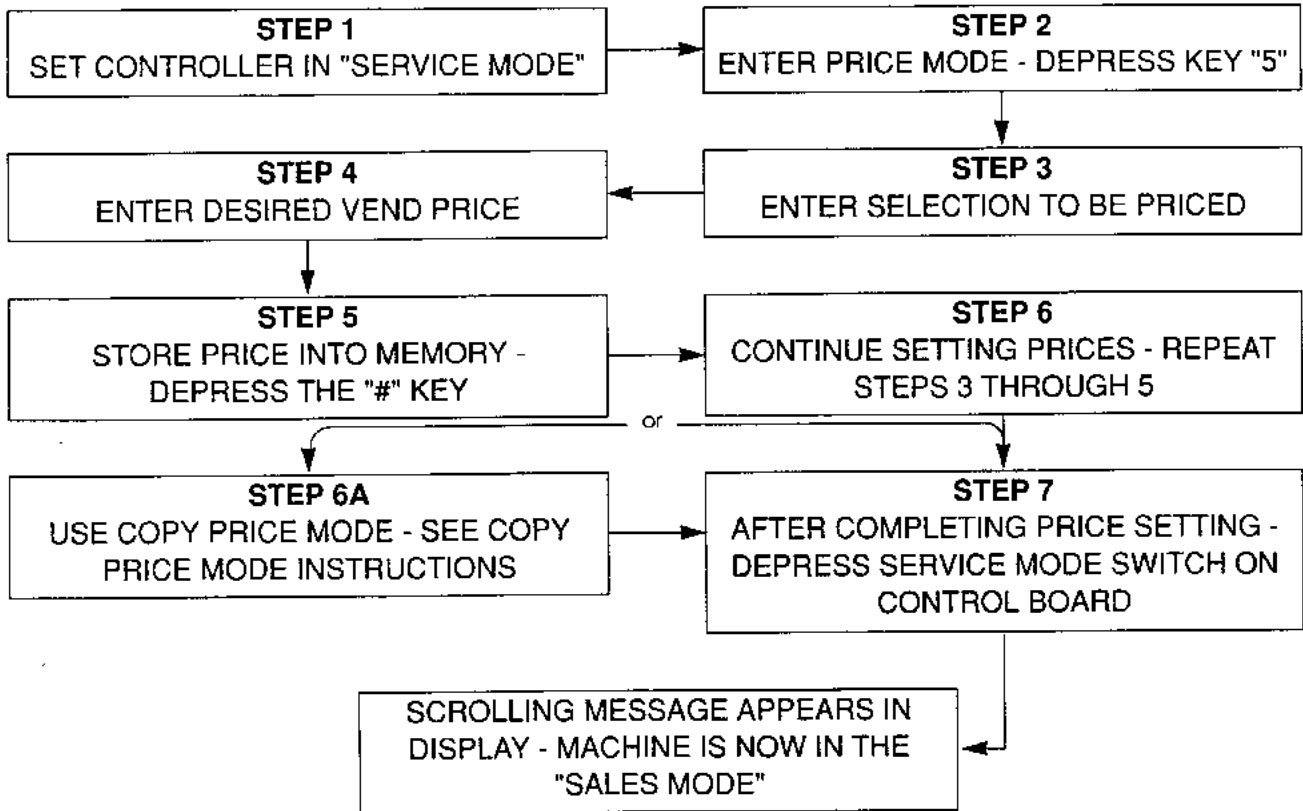
**IMPORTANT:** When establishing vend prices make sure the price label located below the item in the live display agrees with the item being displayed and with the vend price programmed into the Controller.

The "Flow Chart" indicates the basic steps that are required when establishing vend prices on individual selections. If more than one selection is being vended at the same vend price, the "copy price" mode can be used. (See **Illustration #10**)



# PRICE SETTING INSTRUCTIONS

## STEP-BY-STEP SEQUENCE



**GLASSFRONT MERCHANDISER**  
**Selection Pad**  
**ILLUSTRATION #10**

# COPY PRICE MODE INSTRUCTIONS

---

## COPY PRICE

When there is more than one selection to be vended at the same price, the "Copy Price" mode can be accessed by following the instructions outlined below:

1. Place the Controller in the "Service Mode."
  - This is done by depressing the "Service Mode" switch located on the Glassfront Merchandiser control board.
2. Enter the "Price Mode" by depressing Key "5" on the front panel key pad. (See **Illustration #11**)
  - The display will indicate **"Make Selection."**
3. Enter the first selection to be priced.
  - The Selection Number and current vend price will be displayed in the Glassfront Merchandiser display.
4. Enter the desired vend price using the numbers on the Glassfront Merchandiser key pad.

**EXAMPLE:** If the numbers 7 and 5 were entered, all items would have a vend price of 75 cents.

5. Depress the "\*" key on the Glassfront Merchandiser key pad. (See **Illustration #11**)
  - The display will indicate **"Copy Price"**
6. Enter the desired selections to receive the copy price. All selections entered will receive the same vend price.

7. Store the prices in memory by depressing the "#" key on the Glassfront Merchandiser key pad. (See **Illustration #11**)
8. To continue to copy another price, repeat **Step 3 through Step 7.**
9. After completing the price setting, depress the "Service Mode" switch on the Glassfront Merchandiser control board. The scrolling message will appear in the display. The machine is now in the "Sales Mode."

## VERIFYING VEND PRICES

The vend price for each selection can be verified at any time while the machine is in the "Sales Mode." To verify the price programmed into the controller, depress the specific selection numbers. The current vend price will be displayed in the Glassfront Merchandiser for approximately three seconds. The price for each selection is also identified by a "price label" located below each item in the "Live Display." Make sure the price that is programmed into the controller agrees with the price label and is identifying the item in the "Live Display."

**NOTE:** If the "discount" feature is being used, and the discount is in effect, the "discounted" vend price will be displayed. For information on discounts **SEE GLASSFRONT MERCHANDISER SERVICE MANUAL.**

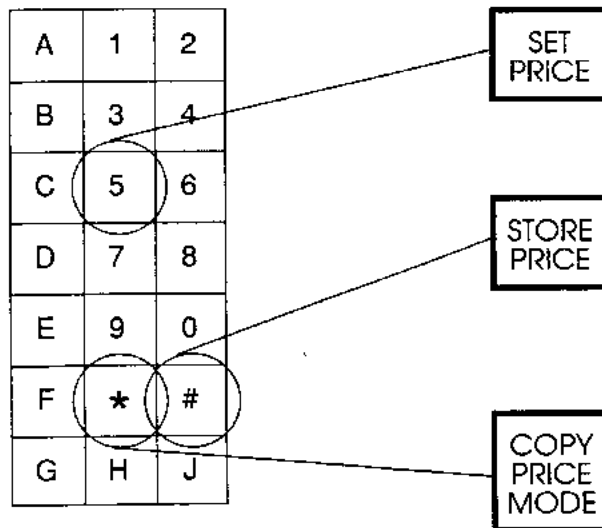
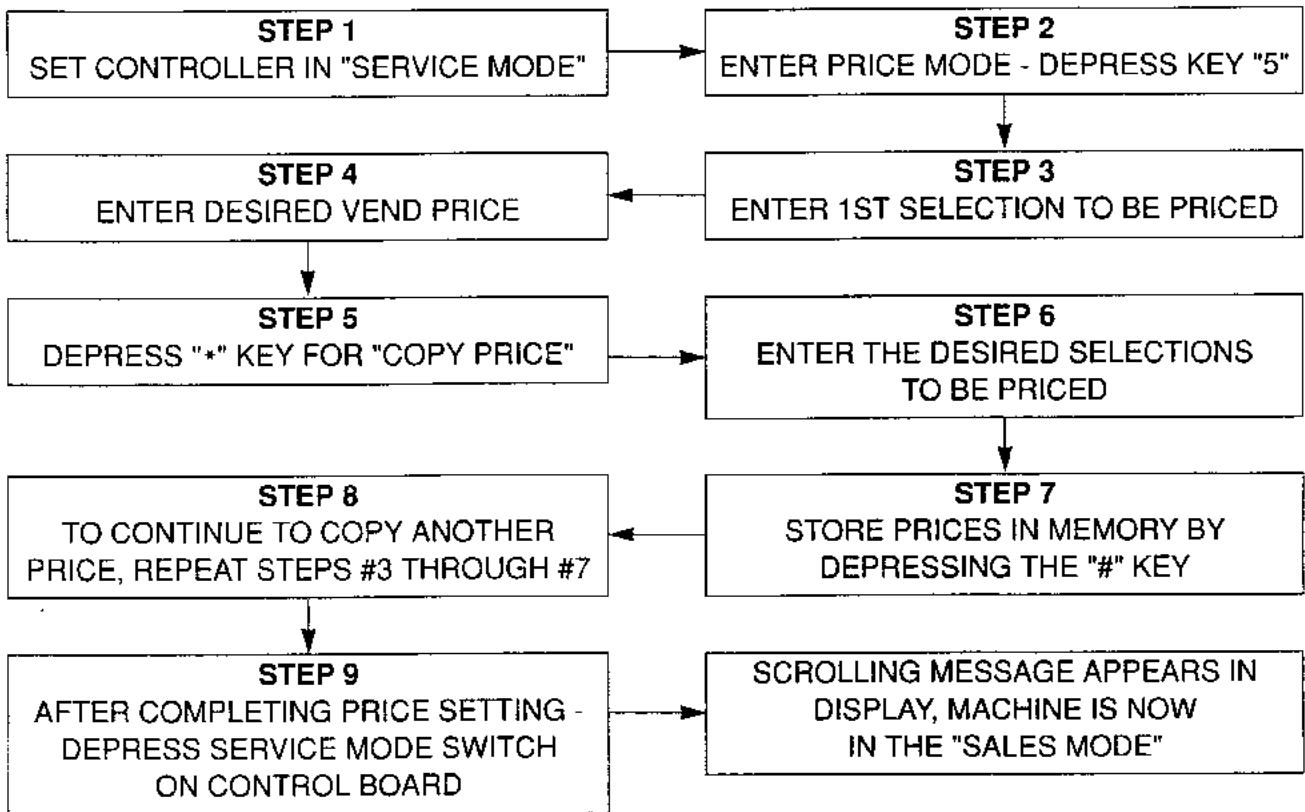
If that specific selection has been identified as a faulty motor circuit or sold-out has been removed by the Controller, the display will indicate **"SELECT OTHER ITEM."** This indicates that the selection is not functional. To reinstate a faulty selection, place the Glassfront Merchandiser into the "Service Mode" and return to the "Vend Mode."

# COPY PRICE MODE SEQUENCE

## COPY PRICE MODE:

The following "Flow Chart" indicates the basic steps that are required when establishing vend prices using the "Copy Price" option. When establishing prices for individual selections, follow the instructions outlined under "Price Setting Instructions."

### COPY PRICE MODE STEP-BY-STEP INSTRUCTIONS



**GLASSFRONT MERCHANDISER**  
**Selection Pad**  
**ILLUSTRATION #11**

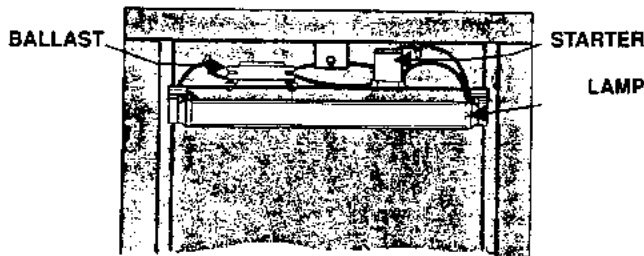
# FUNCTIONS & COMPONENTS

## CABINET HEATER WIRE

There is a rope-type cabinet heater around the front insulated edge of the main cabinet. This heater is 25-watts, 118 inches long, 55 ohms per foot. It operates on a 115 VAC line. The purpose of this heater is to help prevent condensation from forming around the door and cabinet seal.

## LIGHT ASSEMBLY

The light assembly is located above the display cans. To gain access to this assembly, the display must be removed. The light assembly consists of a fluorescent lamp, 2 starters and a ballast. (See **Illustration #12**)

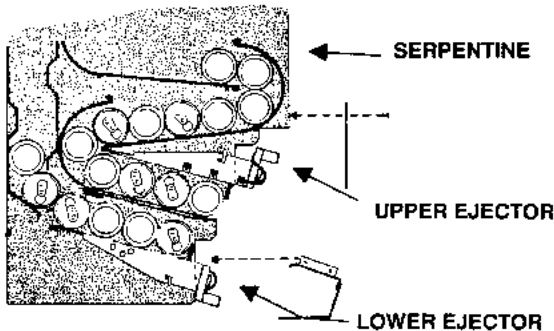


**ILLUSTRATION #12**

## UPPER AND LOWER EJECTORS

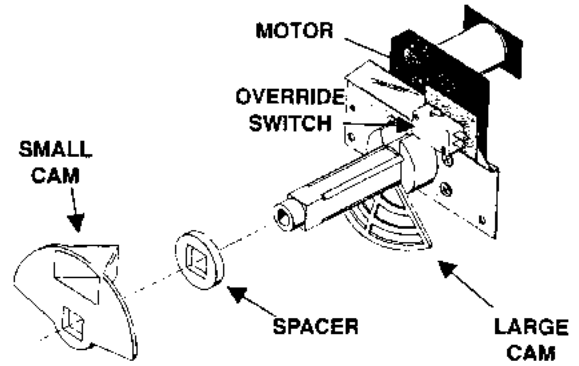
These ejectors receive their power from the Glassfront Merchandiser control board, through the "H" shelf harness connector. These ejectors, through the empty switch, indicate to the control board that a particular column is out of product. This will be displayed in the Glassfront Merchandiser and "MAKE ANOTHER SELECTION" when that selection is attempted.

The upper ejector mechanism dispenses product from columns 2-4-6 only. The lower ejector mechanism dispenses product from columns 1-3-5 only. (See **Illustration #13**)

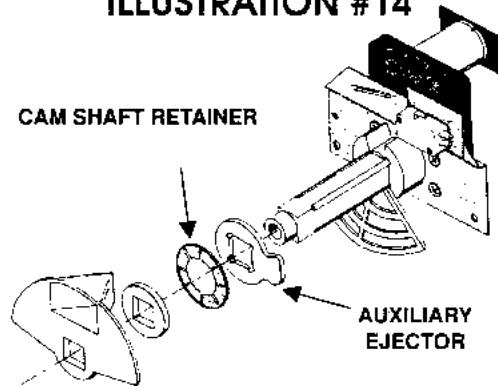


**ILLUSTRATION #13**

These assemblies are made of the same components with the exception of the lower ejector mechanism having an auxiliary ejector and cam shaft retainer added: (See **Illustrations #14 & 15**)



**Upper Ejector  
ILLUSTRATION #14**



**Lower Ejector  
ILLUSTRATION #15**

## Vend Motor:

This motor is 24 V.D.C., operated from the Glassfront Merchandiser control board through an umbilical harness from the "H" plug in the Glassfront Merchandiser cabinet.

This motor is mounted to the plate using four (4) screws and then the plate secured to the ejector frame by three (3) screws. (See **Illustration #14**)

## Large Cam:

This cam is positioned on the ejector mechanism in a manner to hold a can at the vend position. As the motor runs the cam is rotated, releasing the can being held at the vend position to the vend area. At the end of the motor cycle, the cam is returned to the stand-by position.

## Small Cam:

This cam at stand-by is located above the second can up the rail. As the motor rotates, the cam separates the first and second can and prevents the second can from vending. At the end of the cycle, the can is released to the vend area to be held by the large cam.

## Spacer:

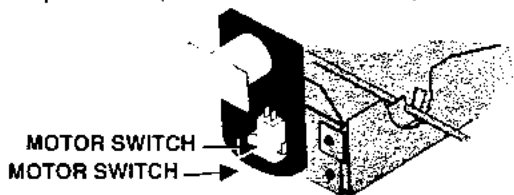
This spacer is used as an adjustment for different diameter cans, 10 or 12 oz. This is done by placing it in front or behind the small cam. (See **Illustration #14**)

## Override Switch:

This switch is mounted on the motor plate and actuated by the large cam when in a cycle. At standby, this switch should be in the notch of the large cam. This switch supplies power to the vend motor during a cycle, overriding the "Sold Out" switch when it is actuated by the cans moving to the vend position. (See **Illustration #14**)

## Motor Switch:

The switch, when actuated at the start of the motor cycle, sends a signal to the controller that the motor has successfully started. At the end of the motor cycle, the switch will deactuate, indicating to the controller that the motor has cycled 360 degrees. At this time the controller will remove power from the motor. False or erratic signals from this switch will cause the controller to stop the motor out of sequence. (See **Illustration #16**)

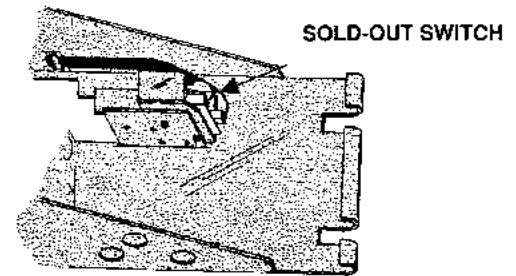


**ILLUSTRATION #16**

## Sold-Out Switch:

This switch is mounted behind the small cam on its own bracket and is adjustable for 10-ounce or 12-ounce cans.

This unit will not dispense the last can in the column, assuring a pre-cool can in each column. (See **Illustration #17**)



**ILLUSTRATION #17**

When this switch is not actuated by a can, the circuit to the Glassfront Merchandiser control board indicates "MAKE ANOTHER SELECTION."

**NOTE:** When a column is sold-out, the service mode button in the Glassfront Merchandiser must be depressed to reset sold-out conditions after filling.

## UPPER EJECTOR MECHANISM REMOVAL

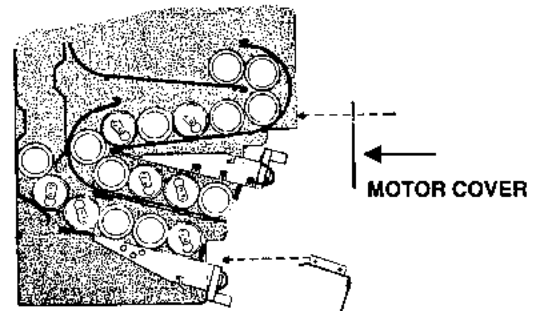
Before removing the ejector mechanisms, the product must be removed or held back in the serpentine column.

**CAUTION:** The motor can be rotated clockwise slowly by hand. Damage to the motor could result if rotated too fast or in the wrong direction.

To remove the upper vend mechanism proceed as follows:

**NOTE:** If only the motor needs removed follow **Step 1** through **Step 4**.

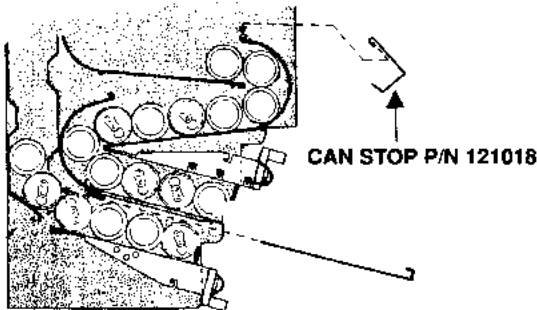
1. Remove the motor cover. (See **Illustration #18**)



**ILLUSTRATION #18**

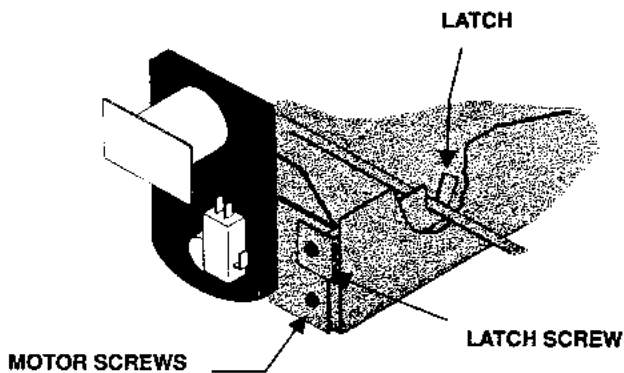
# FUNCTIONS & COMPONENTS

2. Insert the upper can stop (P/N 1211018) by hooking it over the rod and clamping it down around the can. (See **Illustration #19**)



**ILLUSTRATION #19**

3. Loosen the latch screw, so the latch drops out of the way. (See **Illustration #20**)

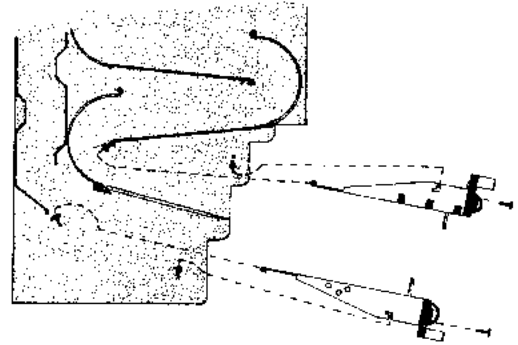


**ILLUSTRATION #20**

4. To remove the vend motor remove the two motor screws. (See **Illustration #20**)

**NOTE:** After motor screws have been removed, pressure will be needed to pull the motor off the cam drive shaft.

5. To remove the complete ejector mechanism without removing the motor, rotate the cam clockwise slowly by hand to remove ten (10) cans.
6. After the cans have been removed from the ejector mechanism, the ejector mechanism can be removed. Push the ejector mechanism backward until it clears the rod and drops down and out. (See **Illustration #21**)



**ILLUSTRATION #21**

## RE-INSTALLING UPPER EJECTOR MECHANISM

With cans being held back or removed from rack:

1. Insert the ejector mechanism into the can rack. (See **Illustration #21**)
2. Hook the ejector mechanism on the rod in back of the rack. (See **Illustration #21**)
3. Lift up and hook the ejector mechanism on the front rod, and push back into the rack. (See **Illustration #21**)
4. Tighten the ejector mechanism latch screw. (See **Illustration #20**)
5. Re-connect wiring, remove can stop and test vend.
6. Install motor cover.

## LOWER EJECTOR MECHANISM REMOVAL

Before removing the lower ejector mechanism, the product must be removed or held back in the serpentine column.

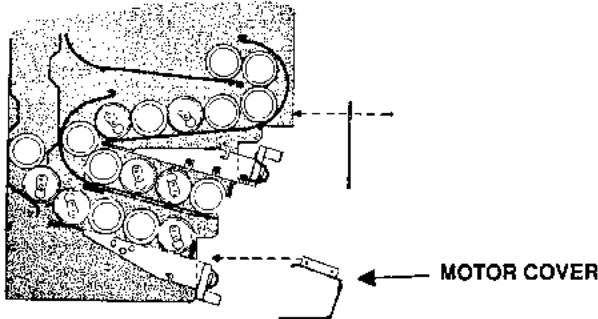
**CAUTION:** The motor can be rotated clockwise slowly by hand. Damage to the motor could result, if rotated too fast or in the wrong direction.

To remove the lower ejector mechanism proceed as follows:

**NOTE:** If only the motor needs removed follow **Step 1 through Step 4**.

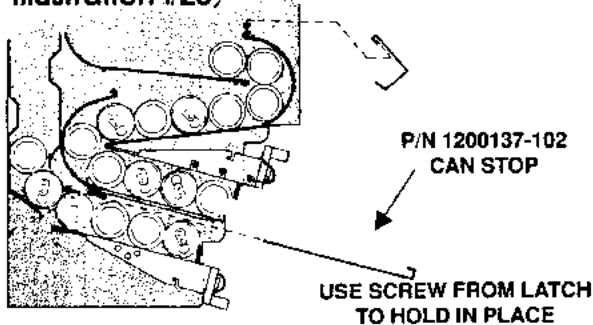
# FUNCTIONS & COMPONENTS

1. Remove the lower motor cover assembly, by removing the four (4) screws. (See **Illustration #22**)



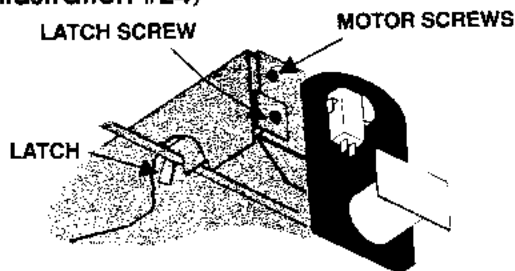
**ILLUSTRATION #22**

2. Insert the lower can stop (P/N 1200137-102) by sliding the can stop all the way in and screwing down the fastener. (See **Illustration #23**)



**ILLUSTRATION #23**

3. Remove the latch screw and latch. (See **Illustration #24**)

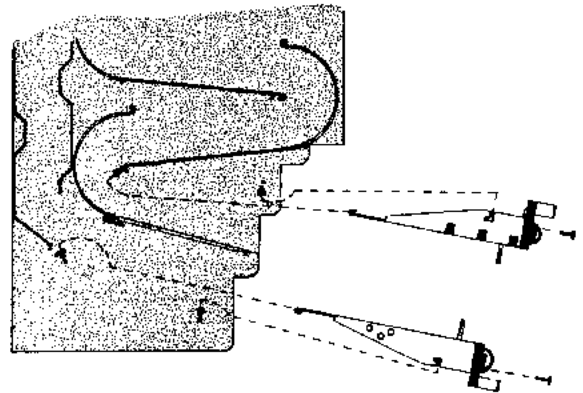


**ILLUSTRATION #24**

4. To remove the vend motor remove the two motor screws. (See **Illustration #24**)

**NOTE:** After motor screws have been removed, pressure will be needed to pull the motor off the cam drive shaft.

5. To remove the complete ejector mechanism without removing the motor, rotate the cam clockwise slowly by hand to remove five (5) cans. The cam must be pointing upward to enable the mechanism to be removed.
6. After the cans have been removed from the ejector mechanism the ejector mechanism can be removed. Push the ejector mechanism backward until it clears the rod and drops down and out. (See **Illustration #25**)



**ILLUSTRATION #25**

## RE-INSTALLING LOWER EJECTOR MECHANISM

With cans being held back or removed from rack:

1. Insert the ejector mechanism into the can rack. (See **Illustration #25**)
2. Hook the ejector mechanism on the rod in back of the rack. (See **Illustration #25**)
3. Lift up and hook the ejector mechanism on the front rod, and push back into the rack. (See **Illustration #25**)
4. Tighten the ejector mechanism latch screw. (See **Illustration #24**)
5. Re-connect wiring, remove can stop and test vend.
6. Install motor cover. (See **Illustration #22**)

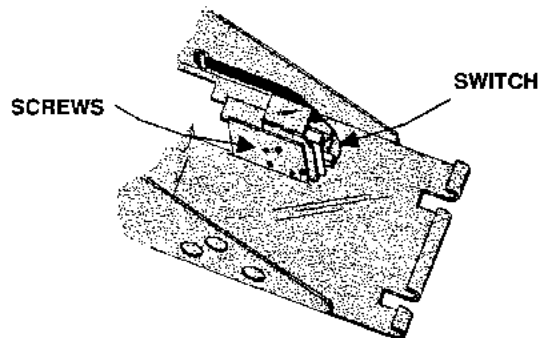
# FUNCTIONS & COMPONENTS

## 10-OUNCE CONVERSION

The upper or lower ejector mechanisms are adjustable to dispense either **10 or 12-ounce can drinks**. The adjustments are made by moving a spacer and sold out switch to make up the difference in size of the can.

To convert to 10-ounce cans, proceed as follows:

1. Remove the ejector mechanism as described in **EJECTOR REMOVAL**.
2. Remove the cam assembly from the metal assembly.
3. Remove the two screws holding the sold-out switch in position. Move switch to the center mounting holes and secure with same screws. (See **Illustration #26**)



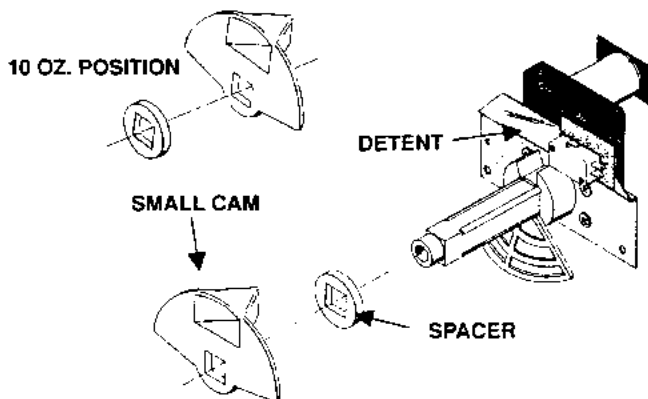
**ILLUSTRATION #26**

4. Remove the small cam. (Note relation in position of small cam to large cam.) (See **Illustration #27**)
5. Remove the spacer.
6. Re-assemble small cam with molded point facing large cam.
7. Re-assemble spacer.
8. Re-assemble entire ejector mechanism, make sure the override switch actuator is in the detent or cut-out of large cam. (See **Illustration #27**)

9. Install motor assembly.

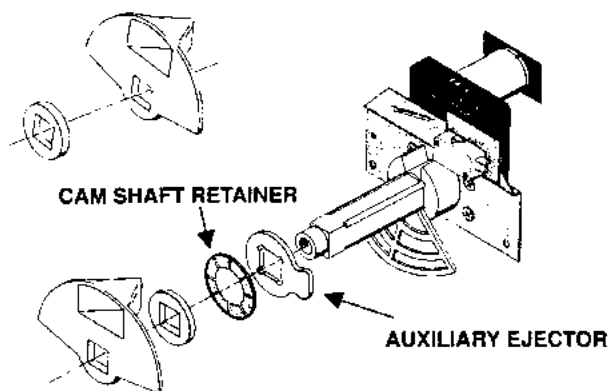
10. Re-install ejector mechanism assembly into the rack.

11. Connect to electrical, remove can, stop, hold back and test vend with coin.



**Upper Ejector  
ILLUSTRATION #27**

**NOTE:** When converting the lower ejector mechanism, **DO NOT REMOVE THE AUXILIARY EJECTOR OR RETAINER.** (See **Illustration #28**)



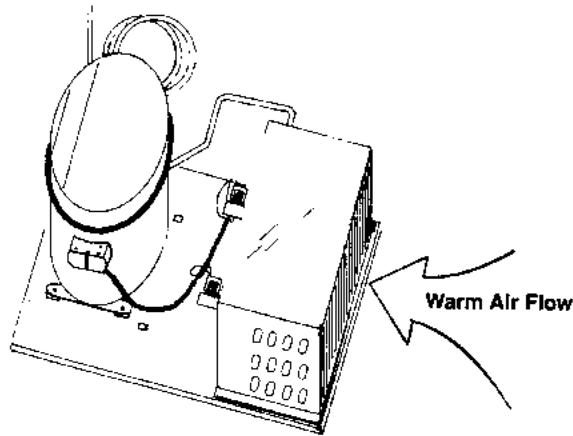
**Lower Ejector  
ILLUSTRATION #28**



# REFRIGERATION SYSTEM

## COMPRESSOR

This unit uses 1/4 horsepower hermetically-sealed compressor. Access to the compressor unit is accomplished through the back of the Can Drink Merchandiser. For this unit to operate at peak efficiency, it is necessary to keep the condenser coil and air intake screens clean and free of any blockage. (See **Illustration #29**)



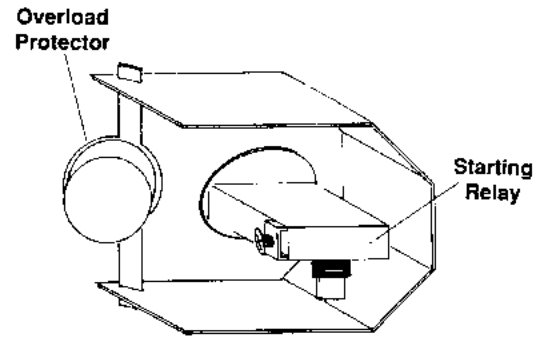
**ILLUSTRATION #29**

### Power Supply:

A main power supply of 115 VAC, 60 Hz, with an operating amperage of 10 amps is the requirement to provide the power for this unit.

### Starting Relay:

A current-dependent electromagnetic starting relay is used for cutting in and out the compressor motor start or main windings. When the relay coil and the main windings are subjected to the initial high start-up current, the relay contacts close. During the acceleration of the motor, the current through the main windings of the motor and the relay coil falls. When this current falls below a preset value, the relay contacts open and the start windings drop out of the circuit. The run windings, which are always in the circuit, continue to run the compressor efficiently until the cold control is satisfied and shuts off. Care must be taken in the replacement of the relay which is precisely sized to each compressor model. (See **Illustration #30**)



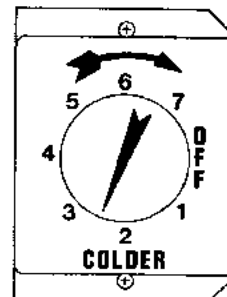
**ILLUSTRATION #30**

### Overload Protector:

This bimetallic protector permits the compressor motor to perform beyond its normal duty up to a predetermined safe temperature limit without cutting off its power supply. The protector uses bimetallic discs to control a normally-closed switch. Heating of the bimetallic discs is a function of both temperature around the protector and the internal heat generated by the motor current through the discs. When the heat has reached the predetermined temperature, the bimetallic discs' contact will open causing the power to the compressor to stop. Once again care must be taken in the replacement of this device as it is sized precisely for each compressor model. (See **Illustration #30**)

### Cold Control:

This device is the primary control which starts or stops the refrigeration unit. This control is adjustable and should be set normally between 2 and 3. As the temperature inside the insulated cabinet changes, the control will either turn on or shut off the refrigeration unit. (See **Illustration #31**)



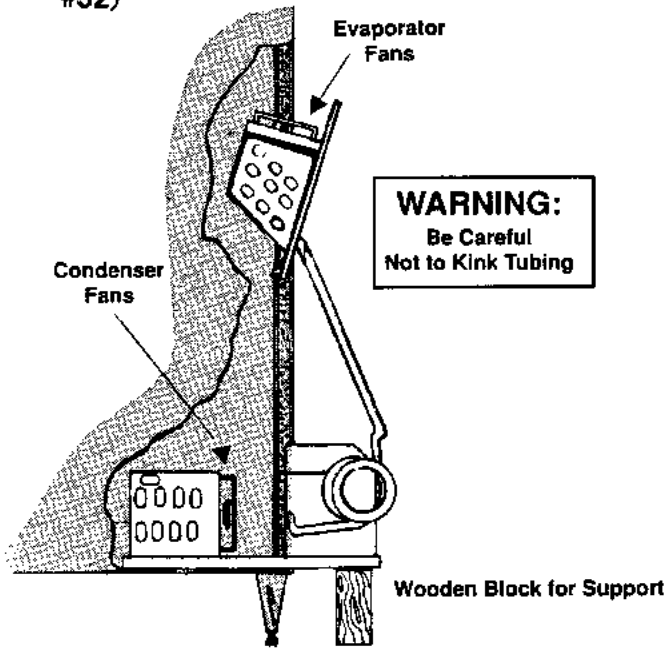
COLD CONTROL SETTING	AVERAGE ROOM TEMPERATURE
1	
2	80°F to 110°F
3	65°F to 85°F
4	
5	
6	

**ILLUSTRATION #31**

# REFRIGERATION SYSTEM

## Evaporator Fans:

There are two (2) 25-watt, clockwise rotation, 115 VAC, 60 Hz. fan motors mounted to the evaporative coil circulating air inside the insulated cabinet. These motors should both operate continually while there is power to the machine. (See **Illustration #32**)



**ILLUSTRATION #32**

## Condenser Fans:

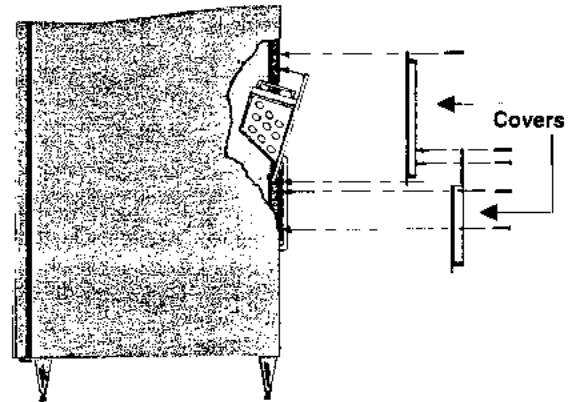
There are two (2) 25-watt, clockwise rotation, 115 VAC, 60 Hz. fan motors mounted to the condenser coil, drawing air through the condenser. These fan motors will cycle with the compressor, which is controlled by the cold control. "See Cold Control" (see **Illustration #31**).

## REFRIGERATION SYSTEM REMOVAL

To remove the refrigeration system, it is necessary to remove the evaporator assembly with the compressor assembly. Be careful not to kink or break the refrigeration tubing. To remove, proceed as follows:

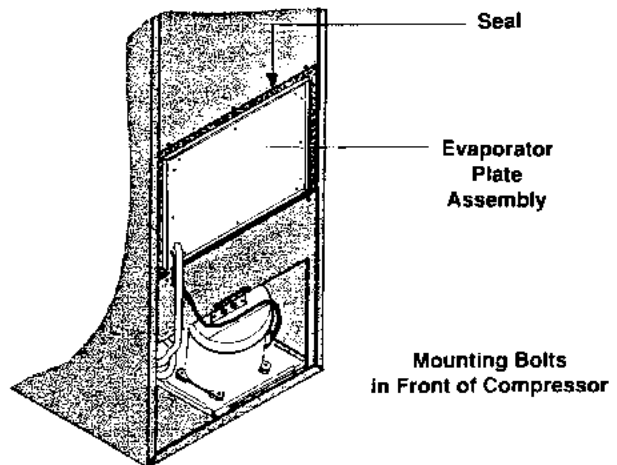
1. Disconnect the electrical power to the machine.

2. Disconnect the electrical wiring from the temperature control inside the refrigeration cabinet.
3. From the back of unit, remove the two covers; the small cover protecting the tubing, and the large cover over the evaporator plate assembly. (See **Illustration #33**)



**ILLUSTRATION #33**

4. Remove two nuts and bolts holding compressor assembly into bottom of unit. (See **Illustration #34**)



**ILLUSTRATION #34**

5. Remove the screws securing the evaporator plate assembly in place and pull back on plate assembly to loosen seal around plate assembly. (See **Illustration #34**)

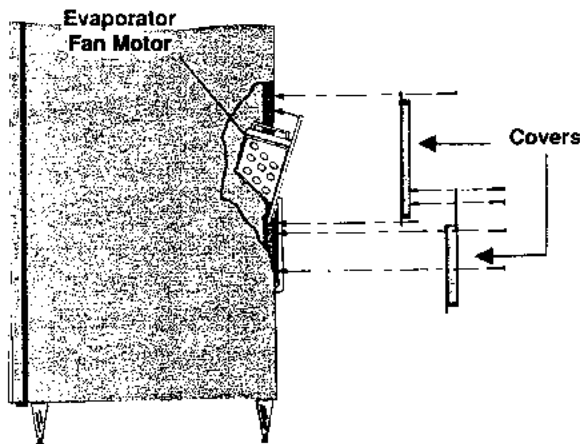
# REFRIGERATION SYSTEM

**CAUTION:** Be careful to not kink or break the copper tubing.

6. Starting at the bottom of the compressor unit, lift up on base plate to clear leg mounting bolts and slide compressor unit out the back opening. (See **Illustration #32**)
7. Once unit is out of cabinet, lower to floor and remove evaporator plate assembly.
8. With total unit out, support the evaporator assembly (so not to damage tubing).
9. Re-install unit in reverse order. Again being careful not to damage unit.
10. Connect the system to electrical power, set temperature control and test run unit.

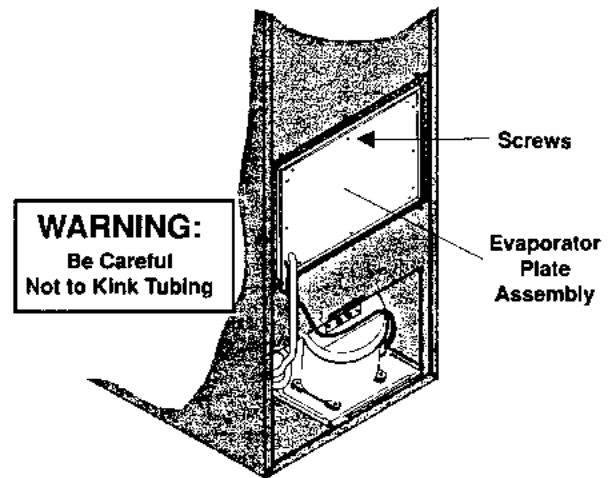
## EVAPORATOR FAN REMOVAL

The evaporator fan motors should be running whenever the Can Drink Merchandiser is connected to 115 VAC power supply. If one or both fan motors should stop, it is possible to frost up the evaporator coil. To replace a fan motor or blade proceed as follows:



**ILLUSTRATION #35**

1. From the back of the machine, remove the two covers; the small cover protecting the refrigeration tubing and the large cover over the evaporator plate assembly (See **Illustration #35**).
2. Remove the screws securing the evaporator plate assembly. (See **Illustration #36**)



**ILLUSTRATION #36**

3. Pull back on the plate assembly to expose the evaporator fan motors and blades. (See **Illustration #35**)

**NOTE:** This plate is sealed in with a sealant between the plate and machine opening frame. Make sure when re-installing that this plate is properly sealed. Improper sealing could cause the evaporator coil to frost up. (See **Illustration #36**)

**CAUTION:** When pulling back on plate assembly, do not bend refrigeration tubing.

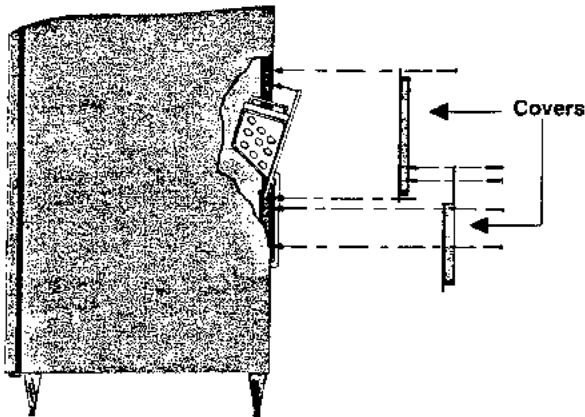
4. Remove broken fan blade or fan motor. Each motor has a separate connection. Install new blade or motor and re-install plate assembly.

# REFRIGERATION SYSTEM

## CONDENSOR FAN BLADE OR MOTOR REMOVAL

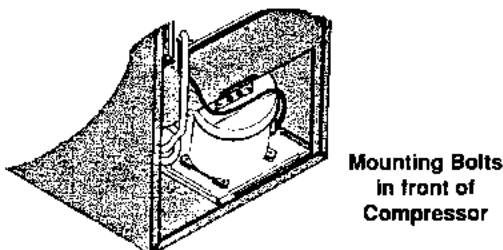
The condenser fan motor assembly will energize each time the compressor cuts in. If a blade or motor fails, it is necessary to replace them or risk damage to the compressor unit. To replace the fan motor components, proceed as follows:

1. Disconnect the electrical power from unit.
2. Remove the small cover over the tubing going to the evaporator coil. Also remove the large cover that protects the evaporator plate assembly. Remove evaporator plate screws and tilt assembly back to allow for partial removal of condensing unit. (See **Illustration #37**)



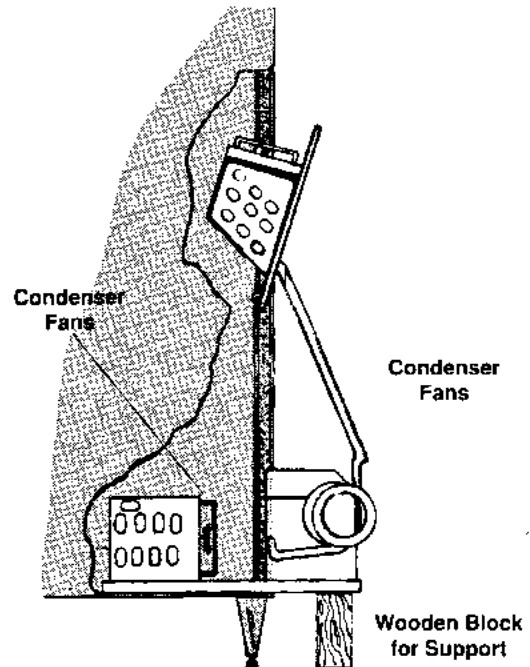
**ILLUSTRATION #37**

3. Unbolt compressor unit from cabinet base, two nuts and bolts. (See **Illustration #38**)



**ILLUSTRATION #38**

4. Lift up on compressor base to clear leg bolts and slide the unit out the back, enough only to gain access to motors. (See **Illustration #39**)



**ILLUSTRATION #39**

**NOTE:** Be careful not to kink or break copper tubing.

5. Once unit is out far enough to gain access to motor, support base off floor to prevent damage to tubing.
6. Remove old components from unit. Replace with new and re-install.
7. Reverse procedure to install unit and test.

---

# REFRIGERATION SYSTEM TROUBLE-SHOOTING

## TROUBLE-SHOOTING

Know and understand service units and how they operate. Units may vary, but the operation is basically the same.

Never guess at the problem; solve it by reading the symptoms.

### I. COMPRESSOR WILL NOT START

- A. Voltage (check to see if compressor has power)
  - 1. Tripped breaker or blown fuse
  - 2. Wall outlet faulty
  - 3. Short or tear in power cord
  - 4. Faulty cold control
    - a) Unplug power supply, remove screws from thermostat. Use a jumper wire, or place screw through terminals; then restore power and check to see if the unit runs.
  - 5. Check for improper wiring

### II. COMPRESSOR TRIPS ON OVERLOAD

- A. Improper voltage (115 AC normal)
  - 5-10% above, 5% below
- B. Overload defective
  - See VIII, B
- C. Relay defective
  - See VIII, C
- D. Compressor defective
  - See VIII, D
- E. Start capacitor defective
  - See VIII, E
- F. Short in other component
  - Isolate and eliminate each electrical component until short is found.
- G. Compressor is too hot
  - 1. Dirty condenser

**NOTE:** Condenser must be kept clean of dirt and debris to allow for proper operation.

- 2. Faulty condenser motor or blade
- 3. Restricted air flow

# REFRIGERATION SYSTEM

---

## TROUBLE-SHOOTING

### III. NOISY OR VIBRATING UNIT

- A. Components rubbing or touching each other
  - 1. Check fan blades and motor
  - 2. Loose shrouds and harness
  - 3. Copper tubing
  - 4. Loose or unsecured parts
- B. Grommets
  - 1. Worn, aged
- C. Compressor
  - 1. Bad valves
  - 2. Slugging
  - 3. Bad windings (see **Schematic #1**)
- D. Relay
  - 1. Frozen in start position (see **Schematic #2**)
- E. Low voltage

### IV. UNIT SHORT CYCLES

- A. Cold Control
  - 1. Differential set too close
  - 2. Probe in wrong area (i.e., touching evaporator)

### V. UNIT OPERATES LONG OR CONTINUOUSLY

- A. Thermostat faulty
- B. Air flow restricted
  - 1. Faulty evaporator motor or blades causing coils to ice over
  - 2. Air flow blocked by product in front of evaporator
- C. Gasket leak
- D. Excessive load
  - 1. After loading, units run longer to pull out excessive heat from product
- E. Shortage of refrigerant or restriction

---

# REFRIGERATION SYSTEM TROUBLE-SHOOTING

## VI. REFRIGERATED SPACE TOO WARM

- A. Restricted evaporator air space
  - 1. Evaporator motor or blades faulty. This causes the coils to ice over the evaporator.
  - 2. Condenser air flow restricted
    - a) Plugged or dirty condenser
    - b) Condenser motor or blades bad
    - c) Blade stuck
  - 3. Condensing space restricted
    - (a) Unit placed too close to a wall
  - 4. Compressor – bad valves
  - 5. Leak or restriction
    - a) Cap tube will start frosting 8 to 10 inches past evaporator connection tube
    - b) Check for oil around brazed connections
  - 6. Thermostat improperly set

## VII. 90% OF ALL REFRIGERATION PROBLEMS ARE ELECTRICAL

- A. Rules for breaking into a sealed hermetic system:
  - 1. **DON'T!** This system was not meant to be worked on outside the Factory Service Center.
  - 2. The four things that can go wrong with a sealed system and should be repaired at the Factory Service Center are:
    - a) **Low Charge** – low charges are caused usually by leaks; look for oil around seals and welds. Unit will not seal properly.
    - b) **Restriction in Systems (unit frosts, then melts)** – not cooling properly, low side in vacuum.
    - c) **Bad valves** – unit does not cool properly; noisy compressor.
  - 3. REMEMBER, **DO NOT** break into a sealed system for any reason – send the unit to the Factory Service Center.

## VIII. TROUBLE-SHOOTING UNIT CIRCUITS USING OHM-VOLT METER

- A. Using volt meter, check power source
- B. Check overload (**NOTE:** power must be off and fan circuit open)
  - 1. Using Ohm meter, check terminals 1 and 3 for continuity. If no continuity is measured (0 Ohms) overload may be tripped. Wait 10 minutes and try again. If still no continuity, overload is defective.

# REFRIGERATION SYSTEM

---

## TROUBLE-SHOOTING

### C. Checking Relay: (See **Schematic #2**)

1. Unscrew lead terminals and remove relay from the compressor.  
(NOTE: keep relay upright)
2. Check terminals 1 and S, or L and S; replace relay if there is continuity
3. Check terminals 1 and M, or L and M; replace relay if there is no continuity

### D. Checking compressor: (See **Schematic #1**)

1. Check winding resistance with Ohm meter.
2. If readings are not within 2 Ohms, compressor is faulty.

## CARE & CLEANING

**CAUTION: Always disconnect power source BEFORE cleaning.**

### CABINET INTERIOR

Wash with a mild detergent and water, rinse and dry thoroughly. Wash occasionally with a quality car wax. Plastic exterior parts may be cleaned with a quality plastic cleaner.

### CABINET EXTERIOR

Wash with a mild detergent and water. Odors may be eliminated by including baking soda or ammonia in the cleaning solution. Remove and clean drain hose to eliminate any deposits that may restrict condensate water flow.

The vend mechanisms **MUST** be kept clean. Any build-up of syrup deposits can cause these mechanisms to malfunction. Use soap and water with great care so as not to get water into the electrical components.

### REFRIGERATION SYSTEM

Clean dust from Condenser and Screen in the front door with a soft bristle brush or a vacuum cleaner. Remove any dirt or debris from the refrigeration system compartment. **If condenser coil is not kept clean, the compressor will overheat or fail, voiding the sealed system warranty.** Clean the condensation pan.



## WINDING RESISTANCE

Approximate Resistance

Reading Across Terminals

USE RXI SCALE

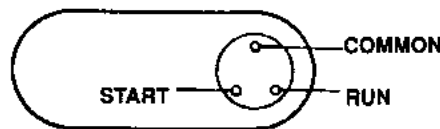
COMMON - Start 12 Ohms

COMMON - Run 2 Ohms

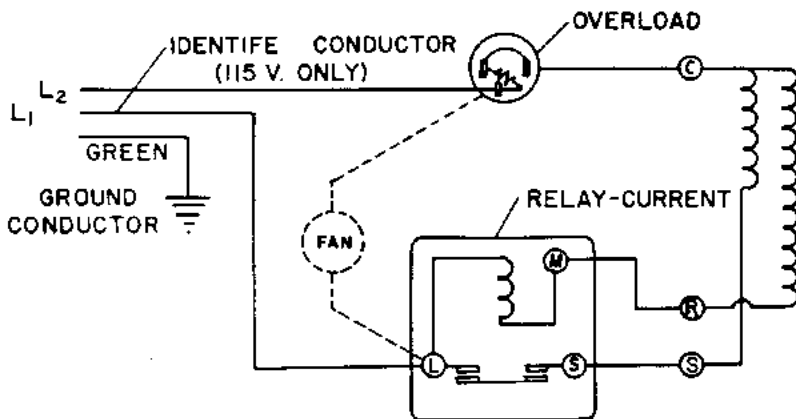
RUN - Start 14 Ohms

COMMON - Shell

No Continuity



**SCHEMATIC #1**



### WARNING

WIRING DIAGRAM MUST BE FOLLOWED AS SHOWN. ANY MISWIRING CAN CAUSE SERIOUS ELECTRICAL HAZARD AND POTENTIAL DAMAGE OR RUPTURE COMPONENT ELECTRICAL PARTS.

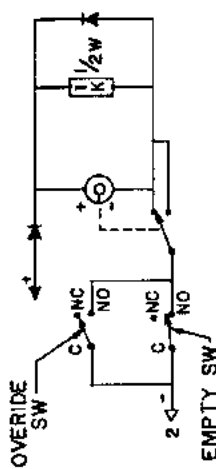
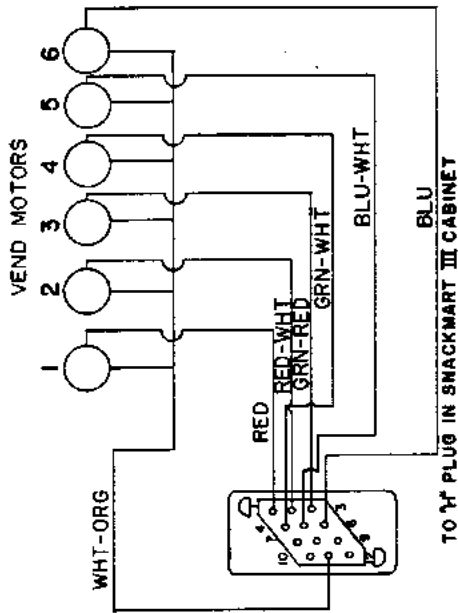
**SCHEMATIC WIRING DIAGRAM - RSIR**

1. When fan is used hookup as shown
2. Identified conductor maybe white or ribbed. (115 V. ONLY)
3. Assemble ports as shown if specified on Bill of Material.

**ALTERNATE NUMBERING**

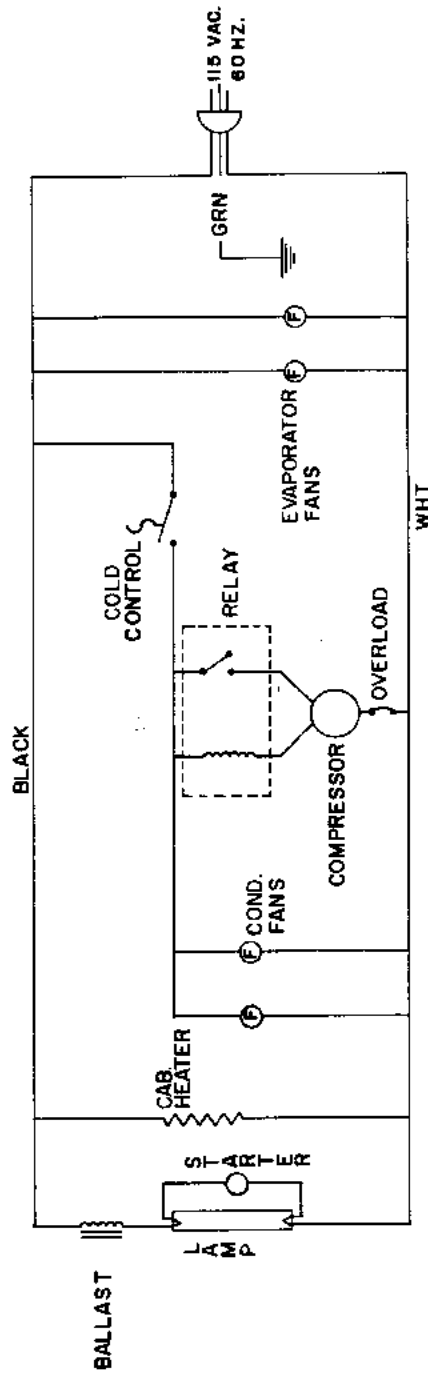
**SCHEMATIC #2**

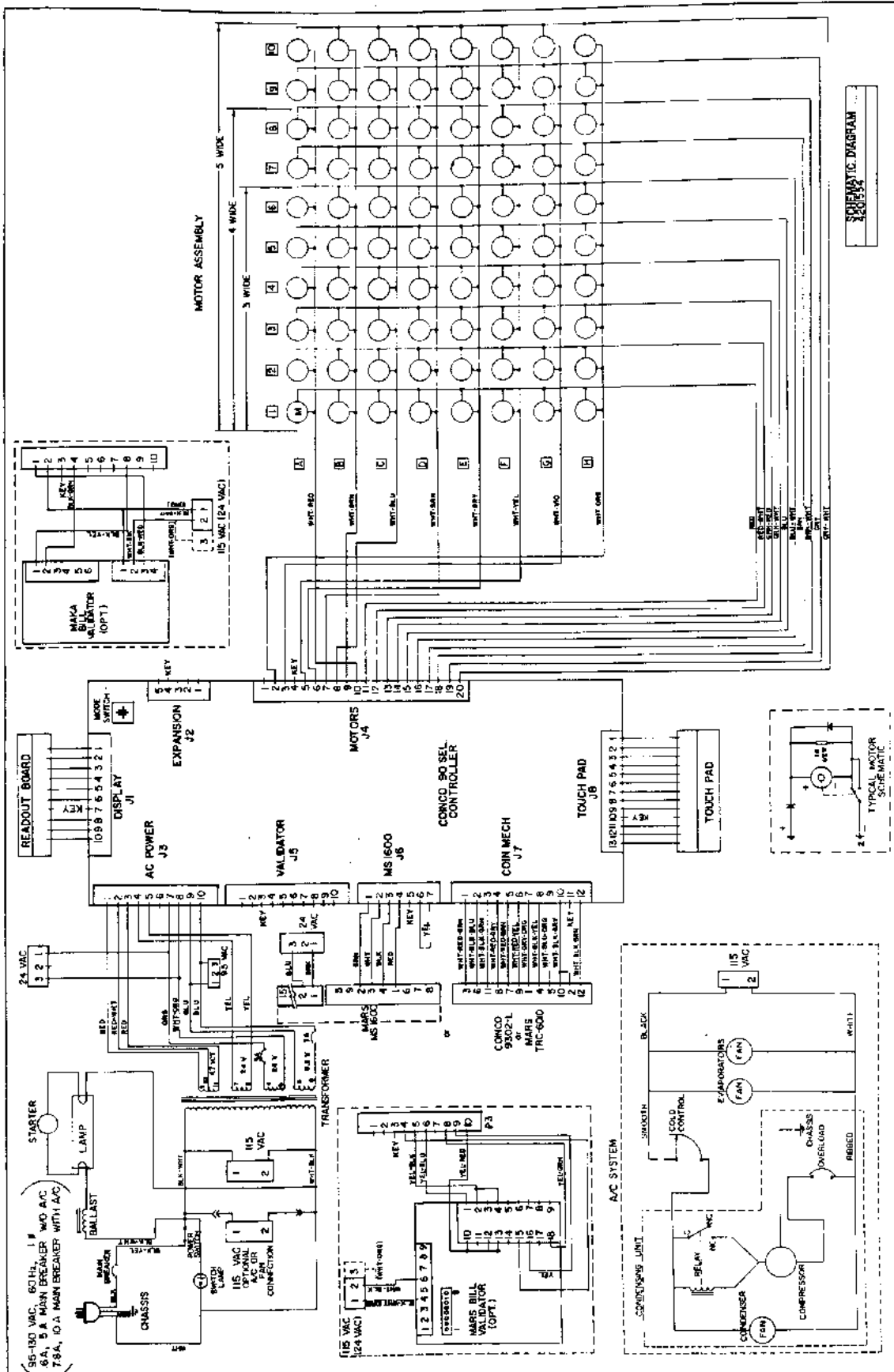
# SCHEMATICS



TYPICAL MOTOR EJECTOR SCHEMATIC  
(SHOWN LOADED WITH PRODUCT)

## CAN DRINK MERCHANDISER SCHEMATIC #3





**GLASSFRONT MERCHANDISER  
 SCHEMATIC #4**

