



Oceana 400



User Manual



## Oceana 400 Installation and User Manual

Product name: Oceana 400

Manual revision: 06

Part Number: USRMAN005806

Release date: February 2017

BEAM Communications Pty Ltd  
5/8 Anzed Court, Mulgrave,  
Victoria, 3170, AUSTRALIA

Information furnished by BEAM Communications Pty Ltd (BEAM) is believed to be accurate and reliable. However, no responsibility is assumed by BEAM for its use, or for any infringement of patents or other rights of third parties, which may result from its use. No license is granted by implication or otherwise under any patent or patent rights of BEAM.

BEAM reserves the right to change specifications at any time without notice.

Copyright © 2017 BEAM Communications Pty Ltd. All rights reserved

## Inmarsat Notification

While the information in this user guide has been prepared in good faith, no representation or warranty, express or implied, is made or given as to the adequacy, accuracy, reliability or completeness of such information. In relation to sections reproduced with permission from Inmarsat Global Limited, Inmarsat Global Limited nor any group company or their respective officers, employees or agents shall have any responsibility or liability to any person resulting from the use of the information in this user guide.

INMARSAT is a registered trademark of the International Mobile Satellite Organisation; the Inmarsat LOGO is a registered trademark of Inmarsat (IP) Company Limited. Both trademarks are licensed to Inmarsat Global Limited.

# CONTENTS

Oceana 400 part number	3	Key features Oceana 400	12	Operation	23
Contents	4	Equipment overview	13	Registration	
About BEAM Communications	5	Installation guidelines	14	RJ11/POTS phone use	
Conventions in this manual	6	Routing cables		Oceana 400 LED status	
Package contents	7	Guidelines for electrical connections		Oceana 400 LED status table	
Optional accessories		Installation procedure	15	Error codes	
Additional information		Installing the OC400 terminal		Type of tones on RJ11/POTS	
Other resources available online		1) Antenna connection		Assuring quality of service	
Safety information	8	2) SIM installation		Specification summary	27
Safety transceiver Oceana 400		3) Wall mounting orientation		Electrical & environmental Specifications - OC400	
Oceana 400 FCC information		4) Rear connector bay		(1) Physical dimensions - OC400	
Electronic devices		5) Connect RJ11/POTS interface		Troubleshooting	29
Pacemakers		6) USB port connection		BEAM warranty terms & conditions	30
Other medical devices		7) Connecting power to the terminal			
Vessels		8) Configuration settings			
Posted facilities					

## About BEAM Communications

**BEAM Communications**, a wholly owned subsidiary of World Reach Limited (WRR), listed on the Australian Stock Exchange, is a world leader in design, manufacture and distribution of specialised communications equipment for the Inmarsat Satellite Network.

**BEAM's** commitment to be at the forefront has continued to increase its share of the global satellite communications market. Its premium distribution network spans the world.

Recognized as a leading provider of satellite communication solutions, **BEAM** specializes in voice, data, tracking and customized solutions. **BEAM** develops innovative products and services to meet market demands and niche applications.

**BEAM's** leading edge products are deployed in a wide range of vertical markets including maritime, transport, government, defence, mining, construction, forestry, emergency services, relief aid, telemetry and rural telephony.

Supported by a dedicated team of professionals, **BEAM** has developed solid relationships with its peers and network of distributors worldwide.



**BEAM Communications Pty Ltd**

5/8 Anzed Court, Mulgrave,  
Victoria, 3170, AUSTRALIA

Web: [www.beamcommunications.com](http://www.beamcommunications.com)  
Information: [info@beamcommunications.com](mailto:info@beamcommunications.com)  
Support: [support@beamcommunications.com](mailto:support@beamcommunications.com)

Tel: +61 3 8588 4500  
Fax: +61 3 9560 9055

## Conventions in this manual

These notes will appear throughout this manual and should be taken into consideration.



### **Warning or Caution**

*This symbol and associated text indicate a warning note providing information to prevent damage to equipment or personal injury.*



### **Note/Important/Tip Header**

*This symbol and associated text indicate a note providing general operating information.*



### **Interference Header**

*All wireless phones may get interference, which could affect performance.*



### **Record Header**

*Write details of your unit for easy reference when required. Ideal when troubleshooting.*

## Terminology

TERM	DESCRIPTION
OC400	Oceana 400 terminal
Falcon	Falcon configuration tool - MS Windows install
SMS	Short Message Service
Mobile Originating	Describes a call initiated by the OC400
Mobile Terminating	Describes an incoming call being answered by the OC400
®	The ® symbol, mark and logos are owned by the respective companies of which the symbol follows. Any use of such marks by BEAM Communications is under license. Other trademarks and trade names are those of their respective owners.
RF	Radio Frequencies
SMA	Sub Miniature version A co-axial RF connection
RJ11	Connector type and reference for the POTS telephone port
POTS	Plain Old Telephone Service
GPS	Global Positioning System
GSPS	Inmarsat's Global Satellite Phone Service
PABX	Private Analogue Branch Exchange
IPxx	Ingress rating specifying the environmental protection.

## Package contents

Check that your OC400 package contains all

of the following items:

- 1 X Oceana 400 terminal
- 1 x ISD710 Maritime antenna (active)

AND

- 1 x 110-240V AC plug pack
- 1 x 10-32V DC power cable
- 1 x USB cable
- User manual & Quick Start Guide

Falcon software is available for download from:

[https://www.beamcommunications.com/  
support/falcon](https://www.beamcommunications.com/support/falcon)

## Optional accessories

The following optional accessories are available for your OC400 terminal

### OC400:

Antenna Cable Kits for active antennas

- ISD932 6m cable kit (active)
- ISD933 13m cable kit (active)
- ISD934 18m cable kit (active)
- ISD935 31m cable kit (active)
- ISD938 40m cable kit (active)
- ISD942 50m cable kit (active)
- ISD943 60m cable kit (active)
- ISD944 70m cable kit (active)
- ISD945 80m cable kit (active)
- ISD946 90m cable kit (active)
- ISD947 100m cable kit (active)

See your service provider for pricing and availability of these quality BEAM accessories.

## Additional information

For the latest in supporting software and documentation for the Oceana 400 terminal please visit:

[www.beamcommunications.com/support/  
oceana400](https://www.beamcommunications.com/support/oceana400)

Oceana 400 supports the Inmarsat GSPS, Isatphone Link and FleetPhone satellite services.

For further information on these services visit:

[www.inmarsat.com](https://www.inmarsat.com)

## Other resources available online

- Advanced configuration – inbuilt to Falcon
- Quick Start Guide & Manual
- Antenna installation guide
- Falcon firmware upgrade if required

## Safety information

---



### **IMPORTANT!**

Please read the following information carefully before installing and using the OC400. Failing to follow instructions may compromise the safety of the product and may result in personal injury and/or equipment damage. Please consult your supplier if you have any further questions.

---

Refer to the appropriate section of this OC400 installation & user manual for additional safety information.

- Store the system in a cool and dry area.
- DO NOT submerge the system in water.
- DO NOT place foreign metal objects or debris in the system. If debris enters into the system, please return to factory for service.



### **WARNING**

DO NOT open equipment. There are no user-serviceable parts inside.

If a DC power supply is to be used, its output must comply with the Safety Extra Low Voltage (SELV) requirements of IEC60950.

All connectors must only be connected to equipment ports which comply with the Safety Extra Low Voltage (SELV) requirements of IEC60950.

### **POTENTIALLY EXPLOSIVE ATMOSPHERES**

- Obey all signs and instructions.
- Sparks may occur during cable installation and could cause an explosion or fire resulting in bodily injury or even death.

- Areas with a potentially explosive atmosphere are often but not always clearly marked. They include, but are not limited to:
  - » fuelling areas such as gasoline stations
  - » below deck on boats;
  - » fuel or chemical transfer or storage facilities;
  - » areas where fuel odors are present (for example, if a gas/propane leak occurs in a car or home);
  - » areas where the air contains chemicals or particles, such as grain, dust, or metal powders;
  - » any other area where you normally would be advised to turn off your vessel engine.



## Safety - Transceiver Oceana 400

The OC400 is a low power radio transmitter and receiver. When it is ON, it receives and also sends out radio frequency (RF) signals.

- The OC400 has an in-built transceiver which is designed to be used with an external antenna. The antenna transmits RF energy. The antenna (fitted via an extension coaxial cable to the terminal) must be located more than > 55cm from the human body (person) when in operation.
- International agencies have set standards and recommendations for the protection of public exposure to RF electromagnetic energy. These standards are based on extensive scientific review by scientists, engineers, and physicians from universities, government health agencies, and industry groups. They review the available body of research to develop ANSI standard. These ANSI standards are reviewed regularly for research development:
  - » International Commission on Non-Ionizing Radiation Protection (ICNIRP) 1996
  - » Verband Deutscher Elektrotechniker (VDE) DIN-0848
  - » United States Federal Commission, Radio Frequency Exposure Guidelines (1996)
  - » National Radiological Protection Board of the United Kingdom, GS 11, 1988
  - » American National Standards Institute (ANSI) IEEE. C95. 1-1992
- Do not operate your satellite telephone when a person is within 55cm of the antenna. A person or object within 55cm of the antenna could impair call quality and may cause the phone to operate at a higher power level than necessary and expose that person to RF energy in excess of that established by the FCC RF Exposure Guidelines.
- As a precaution, please maintain the maximum body distance possible from the antenna during call transmission.



### **IMPORTANT**

*Cellular and satellite terminals or mobiles operate using radio signals and communication networks. Because of this, the connection cannot be guaranteed at all times or under all conditions. Therefore, you should never rely solely upon any wireless device for essential communications, for example emergency calls.*

---

## Oceana 400

### FCC information

This equipment has been tested and found to comply with the limits for a Class B digital devices, pursuant to Part 15 of the FCC Rules. These limits are designed to provide reasonable protection against harmful interference in a residential installation. This equipment generates, uses, and can radiate radio frequency energy and, if not installed and used in accordance with the instruction manual, may cause harmful interference to radio communications. However, there is no guarantee that interference will not occur in a particular installation. If this equipment does cause harmful interference to radio or television reception, which can be determined by turning the equipment off and on, the user is encouraged to try to correct the interference by one or more of the following measures:

- Reorient or relocate the receiving antenna
- Increase the separation between the equipment and receiver
- Connect the equipment into an outlet on a circuit different from that to which the receiver is connected.
- Consult the dealer or an experienced radio/TV technician for help.

This device has been designed to operate with antennas ISD710 AT1595-82, ISD715/ISD720 AT1595-83 and having a maximum gain of 6dBi. Antennas having a gain greater than 6dBi are strictly prohibited for use with this device.

To reduce potential radio interference to other users, the BEAM antenna type and its gain has been designed so that the equivalent isotropically radiated power (EIRP) is not more than that required for successful communication.



#### **WARNING**

*Changes or modifications not expressly approved by BEAM Communications could void the product warranty.*

---

## Electronic devices

Most modern electronic equipment is shielded from RF signals. However, certain equipment may not be shielded against the RF signals from your wireless phone.

## Pacemakers

The Health Industry Manufacturers Association recommends that a minimum separation of 15cm (six inches (6")) be maintained between a wireless phone's antenna and a pacemaker to avoid potential interference with the pacemaker. These recommendations are consistent with the independent research by and recommendations of Wireless Technology Research.

Persons with pacemakers:

- *Should ALWAYS keep the phone more than 15cm (six inches) from their pacemaker when phone is turned ON.*
- *Should turn the phone OFF immediately if you have any reason to suspect interference is taking place.*

## Other medical devices

If you use any other personal medical device, consult the manufacturer of your device to determine if it is adequately shielded from external RF energy. Your physician may be able to assist you in obtaining this information. Turn your phone OFF in health care facilities when any regulations posted in these areas instruct you to do so. Hospitals or health care facilities may be using equipment that could be sensitive to external RF energy.

## Vessels

RF signals may affect improperly installed or inadequately shielded electronic systems in vessels. Check with the manufacturer or its representative regarding your vessel. You should also consult the manufacturer of any equipment that has been added to your vessel. Performance of electronically controlled brake and/or guidance systems can, under certain unique conditions, be subject to interference by mobile radio operation. Although the transceiver meets all requirements regarding RF emissions, you should mount the transceiver as far as possible from the guidance system to minimize any interference.

## Posted facilities

Turn your phone OFF in any facility where posted notices require such as hospitals and on-board aircraft.

## Key features

### Oceana 400

OC400 is an intelligent basic terminal specifically designed for the Inmarsat network. OC400 enables you to use an RJ11/POTS connection with a standard corded, cordless or DECT handset. Alternatively, it can also be interfaced with a PABX system.

### OC400 design

- High quality ABS plastic
- Wall mounting option
- Integrated antenna connections
- IP53 rated rain proof enclosure (when mounted vertically.)

### Power

- Supports 10-32V DC power input
- 110-240V AC plug pack, included

### Intelligent POTS/RJ11 interface

- Supports up to 600m (2000') of RJ11
- Dial, ring & busy tones
- Integrated to PABX system
- Supported standard corded, cordless, & DECT phones
- Autodial & speed dials available

### Other key features

- USB data port
- Status indicator for registration, call & messaging

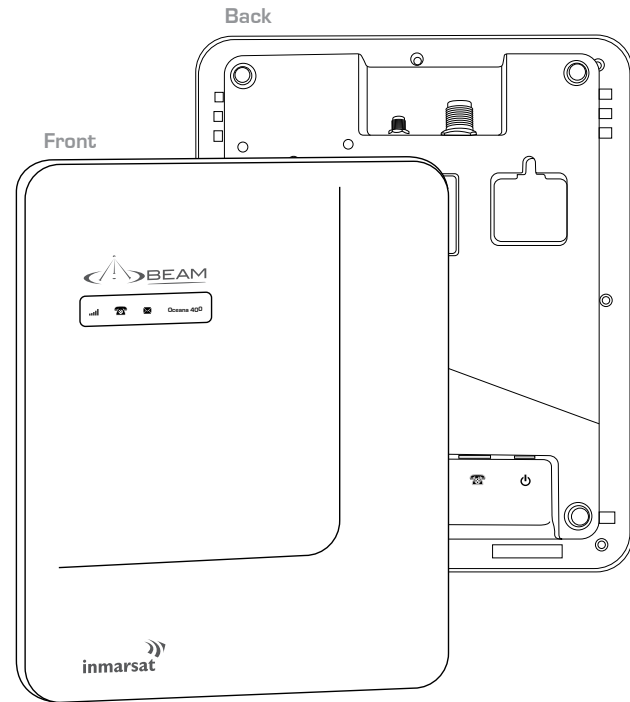

## Equipment overview

1. Signal LED
2. Call LED
3. Message LED
4. Antenna TNC connector
5. GPS SMA connector
6. Wall mounting hooks
7. SIM card slot and cover
8. USB port
9. POTS/RJ11 port
10. Power port

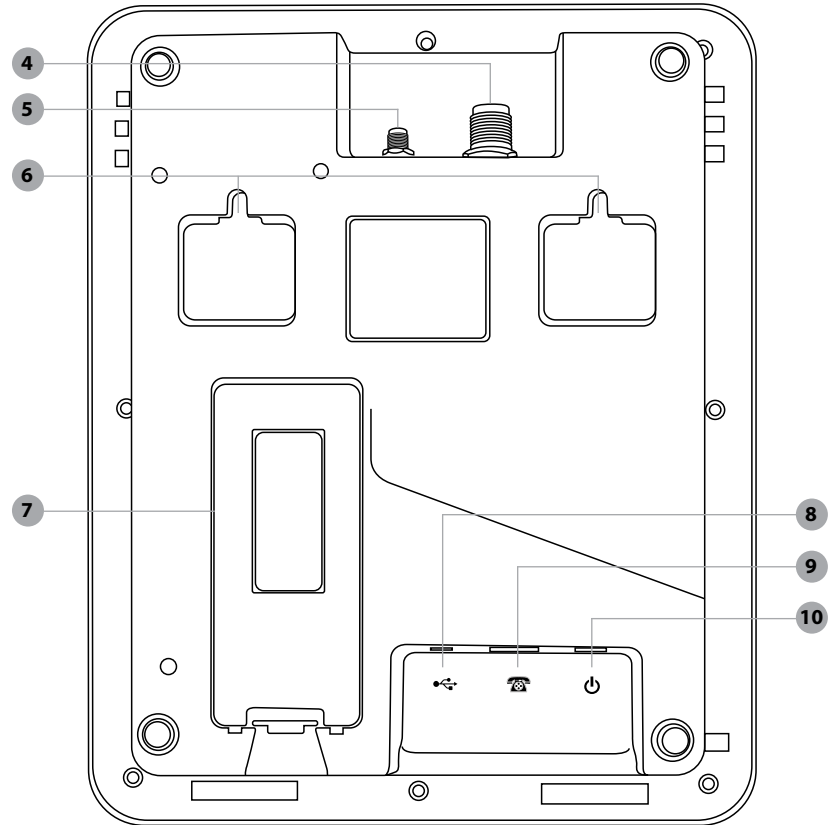
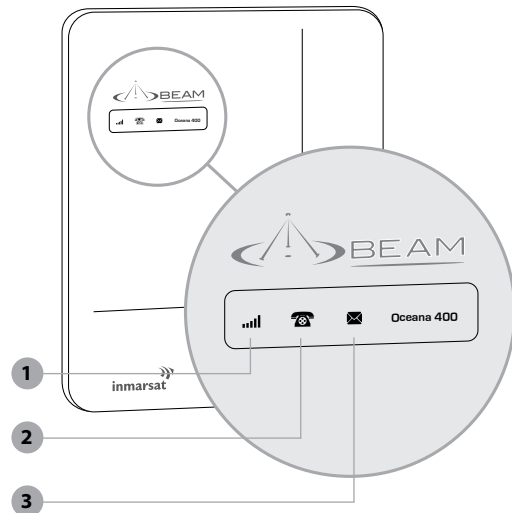

## Installation guidelines

This guide outlines the process for installing the OC400 terminal.

This kit must not be used with any other device.

- Only trained personnel should install this communication equipment.
- Ensure that the units are protected from dirt and moisture.
- Select an area to mount components where there is no interference from other objects.
- Ensure that each mounting surface is strong enough to support the component being mounted to prevent the component from loosening over time.
- Mount all components securely for safe day-to-day operation. Always use the supplied mounting hardware.
- Leave space around the units to allow airflow and ensure there are adequate clearance for cables.
- Ensure the units can be easily accessible for servicing.
- Vertical (wall) mounting orientation is required to maintain IP53 rain protection in a building.

## Routing cables

- Route cables so they are protected from pinching, sharp edges, and crushing.
- Use grommets wherever a cable must pass through a hole in a metal panel
- Keep all in-line connectors accessible.
- For an extra clean installation, a hole may be driven through the surface directly .

## Guidelines for electrical connections

The system is designed to operate in negative ground 10 to 32 V DC electrical systems only.

If using the DC cable lead:

- The best power connection point for the positive primary power lead is the positive terminal of the battery. Often, direct connection to the battery is inconvenient, and you may find it easier to connect the positive leads to the starter solenoid. Always select a point as close as possible to the battery.
- Connect the negative primary power leads to a good ground point when installing on the vessel. If you must attach the negative primary power lead directly to the negative pole of the battery.

- Many parts of a vessel or a work site can produce electrical noise that interferes with the electrical radio system operation. Before you begin installation, ensure that the ignition wiring and connections to the vessel battery are in good working condition.
- Verify that low resistance connections are present between the battery negative terminal, the vessel chassis, and/or the engine block. All wire connections should be clean and tight.



### **WARNING**

*Do not connect the OC400 interface power cable to the unit until the full installation is completed.*

---

## Installation procedure

### Installing the OC400 terminal

Install the components in the following order. More detailed instructions can be found in the sections following.

1. Install the external antenna
2. SIM installation
3. Wall mounting orientation
4. Rear connector bay
5. Connect POTS/RJ11 interface
6. USB port connection
7. Connect power to terminal
8. Configuration settings

### 1) Antenna connection

To connect the OC400 to the antenna, requires the use of certified satellite and GPS antenna cables. These purpose built cables are approved by BEAM to manage the power requirements for the antenna system. The full list of approved cables can be found at [www.beamcommunications.com/oceana400](http://www.beamcommunications.com/oceana400)

1. Refer to the antennas installation guide for antenna mounting and location requirements.
2. Connect the antenna cable labelled "GPS" to the SMA antenna connector labelled "GPS".
3. Connect the antenna cable labelled "Inmarsat" to the SMA antenna connector labelled "ISAT".
4. Connect the GPS-SMA (Female) cable end to the OC400's SMA connector.
5. Connect the TNC (Female) antenna cable end to the OC400's satellite connector.

**Antenna connection diagram for OC400  
Maritime antenna (active)**

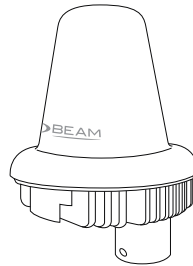
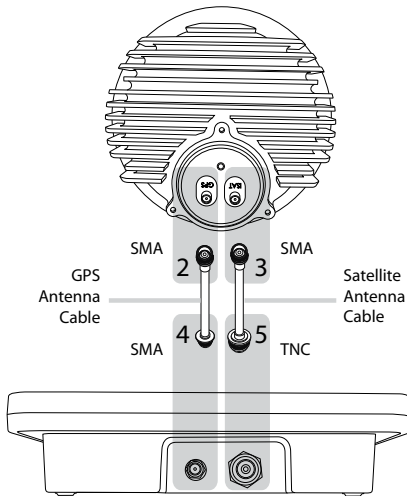

ISD710 Maritime antenna (active).  
For use with OC400



**WARNING**

*DO NOT pull with force on the cables from the rear of the OC400. Please install strain relief clamping for the antenna cables where required. Correct installation of the antenna system is a vital part of the OC400 terminal, to ensure reliable functionality, and drop-free calls.*

**WARNING**

*Changes or modifications not expressly approved by BEAM Communications could void the product warranty.*

**WARNING**

*To satisfy FCC RF exposure requirements for mobile transmitting devices, a separation distance of 55cm or more should be maintained between the antenna of this device and persons during device operation. To ensure compliance, operations at closer than this distance is not recommended.*



**WARNING:**

*Do not place the antenna anywhere there is a source of heat or fumes such as the ship's exhaust.*



**NOTE**

*Refer to the section "Quality of service" page 26, for more information on antenna placement and installation. Only BEAM approved antenna cables should be used with all terminals and antennas.*



## 2) SIM installation

If your service provider has not installed the SIM card for you, follow these steps to install.

1. Disconnect power from the terminal.  
Failure to turn OFF may result in corruption of your SIM card memory.
2. Release the SIM cover by unclipping the latch with your finger or thumb. The SIM cover and latch is shown highlighted below.

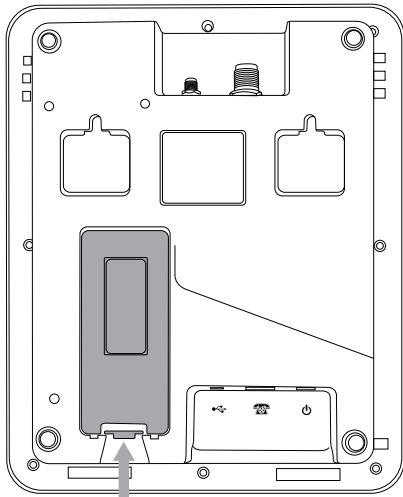

3. The SIM connector is highlighted below.  
Slide the tray guide into the open position with your finger or thumb.

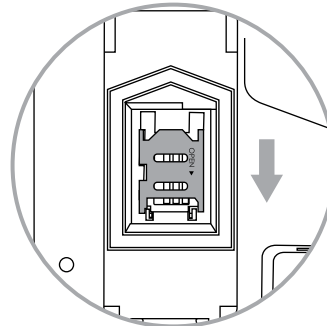

4. Once opened, raise the SIM tray as shown below.

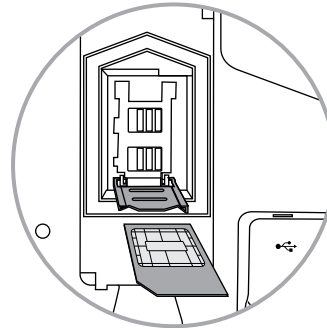

5. Gently insert the SIM card into the tray slots making sure that the golden contacts are facing downwards.
6. Lower the tray and slide the tray guide into the lock position.

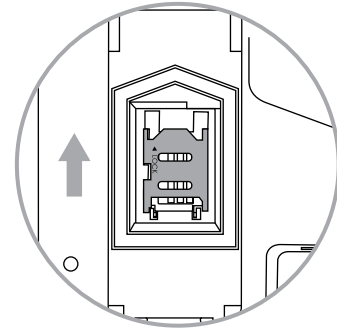

7. Replace the SIM cover.

### 3) Wall mounting orientation

There are two mounting points at the back of the terminal (as shown, shaded, in the below image). The distance (from centre to centre) between the mounting points is 10 cm. To mount the terminal vertically on a wall, sit the two included screws with 4mm remaining out of the wall. Adjust this depth till the terminal hangs securely on the screws.

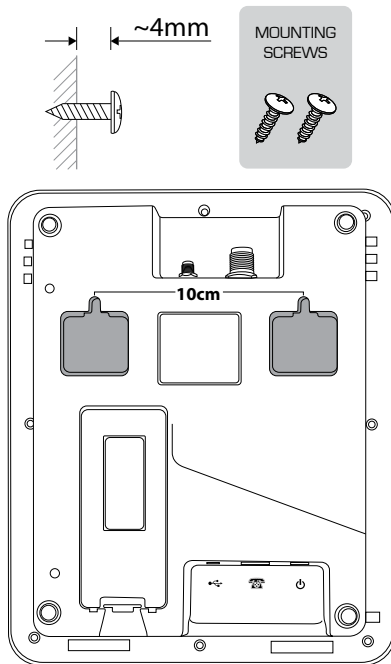

### Optional through-wall

Right angled adapters are optionally fitted to the external antenna connectors to allow the routing of cables through a wall. A "clean" installation free of any visible cabling can be achieved with the use of right angled connectors.

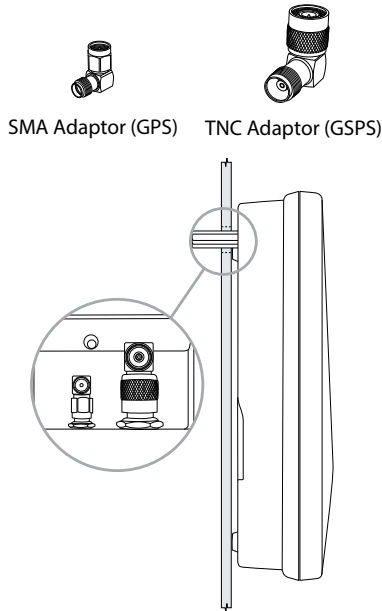

### NOTE

*Vertical (wall) mounting orientation is required to maintain IP53 rain protection.*

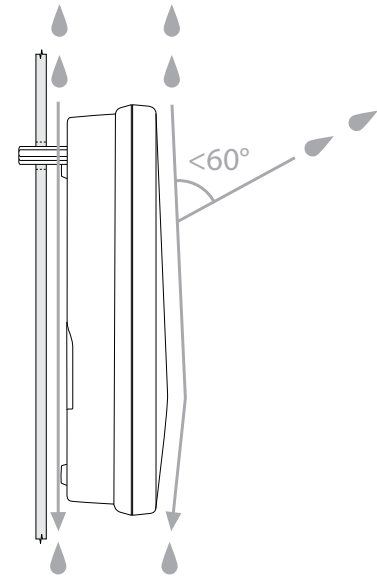

#### 4) Rear connector bay

- A. USB data port
- B. RJ11/POTS port
- C. DC power and accessory input

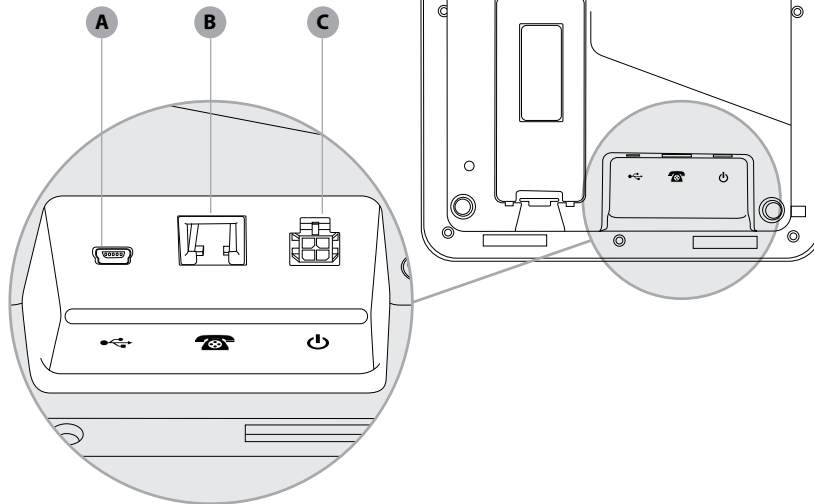

#### 5) Connect RJ11/POTS interface

Any standard analogue POTS telephone (POTS = **Plain Old Telephone Service**) is supported by the OC400 terminal. The terminal supplies power to the analogue phone as well as ring, dial and busy tones.

The analogue phone can be connected by up to 600m (2000') of cabling to the OC400 terminal.

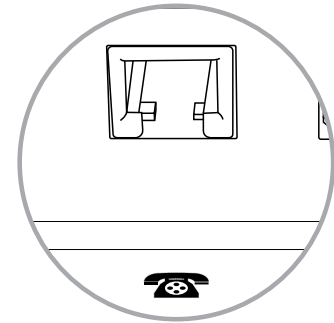

## 6) USB port connection

The OC400 terminal has a mini USB data port to enable upgrading of the firmware, advanced configuration, and data connection.

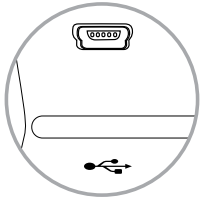

## 7) Connecting power to the terminal

The OC400 terminal can be powered from the supplied AC plug pack, or connected to an external 10-32V DC power source.

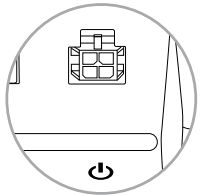

## ISD950 AC plug pack installation

For installation using the ISD950 110-240 AC plug pack, connect the 4-way Microfit connector from the plug pack to the 4-way power connector on the rear of the OC400 terminal. In this configuration the ignition/accessory status is always ON.

## DC power source installation

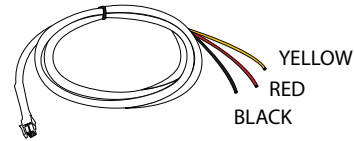

The DC power cable has three wires, RED, BLACK and YELLOW. The RED and BLACK wires are used for the power connection, The YELLOW wire can be connected to a circuit to sync the ON/OFF status of the OC400 terminal with a vessels/in-building operation. By default, the OC400 terminal will stay on for 20 minutes after this input (YELLOW wire) is switched OFF. If a call is in progress while this occurs, the OC400 terminal will stay on for 20 minutes after the call is terminated. Please follow the steps below to connect the DC power cable to the battery power and the OC400 terminal.

1. Route the wire end of the DC power cable to the connection point.
2. Connect the BLACK wire to the negative terminal of the battery.
3. Connect the RED wire to the positive terminal of the battery. It is recommended to add the 5A fuse (supplied) between them.
4. Connect the YELLOW wire to accessory power or ON/OFF switch wire. It is recommended to add a 1A fuse between them. If the SLEEP function is not required, the YELLOW wire MUST be connected to the RED wire.
5. Connect the 4-way Microfit connector on the DC power cable to the 4-way power connector on the rear of the OC400.

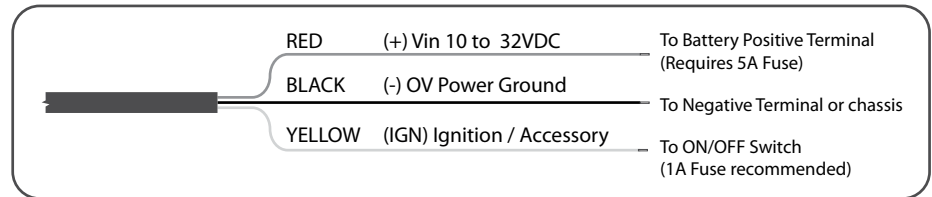

## 8) Configuration settings

The OC400 terminal is ready for you to make voice calls as soon as it is registered. If you wish to customise the operation of your OC400 the Falcon application is required. The first step is to install the BEAM USB driver.

### USB driver installation

OC400 terminal USB data port requires an interface driver to be installed on the user's computer prior to undertaking data communication. This driver supports the following operating systems:

#### Windows XP (SP3 or above) & Windows 7

The Windows driver for the OC400 is contained in the Falcon software download. If required separately, the USB driver can be downloaded from:

<https://www.beamcommunications.com/support/oceana400>



#### NOTE

MAC OS is not supported by this software.

---

### Configuration using Falcon

Falcon can be downloaded from:

<https://www.beamcommunications.com/falcon>

Follow the instructions in the downloaded application to install. Once complete, connect your PC to the USB port of the terminal and start Falcon. You can then use the application for a range of options such as:

- View the status of the terminal (signal, temperature, input voltage)
- Firmware maintenance
- Configure different POTS/RJ11 settings
- Configure power modes
- SIM card PIN/PUK handling

### Configuration Using Remote Commands

Configuration instructions or “Remote Commands” can be sent to the terminal via SMS, and most settings are supported that are normally accessible from Falcon. Please refer to the Falcon user manual for more information.



#### NOTE

*Due to memory limitations it is recommended that users have no more than 20 SMS messages in their inbox. If this amount is exceeded the processing of remote commands and the ability to retrieve the messages via the Falcon tool may be compromised.*

---

## SIM PIN Use

If your SIM card requires activation, follow the instructions provided by your authorised Inmarsat service provider.

Your SIM has a PIN which can be enabled to be entered each time the terminal is powered. If you require to use the PIN for extra security then follow these steps during power-up to enter the SIM PIN and allow the unit to register on the network:

1. Turn ON power to the OC400 terminal. The signal LED will flash RED.
2. It may take a few minutes for the OC400 terminal to register. If a busy tone is heard ON HOOK wait a few moments before trying again.
3. Lift the RJ11/POTS handset, and listen for a PIN tone. (See "Types of tones on RJ11/POTS" page 25).
4. Enter the PIN on the handset keypad, followed by the # button.
5. Hang up the RJ11/POTS handset and wait for the OC400 terminal to acquire lock and registration.

Alternatively, the SIM PIN can be disabled so that the terminal will automatically register. Please use Falcon to perform this SIM card configuration. Falcon also allows the SIM PIN to be changed, and the PUK code to be entered if SIM is locked.



### NOTE

*If you enter the PIN incorrectly 3 times, the SIM card locks, and you need to enter the PUK. You must use the PUK code supplied by your service provider to unlock the SIM. If you don't have a PUK code please contact your service provider.*

### SIM PUK

If you have locked your SIM card, you can enter the PUK and then reset the PIN via Falcon. You must use the PUK code supplied by your service provider to unlock the SIM. Alternatively you can enter the PUK via the RJ11/POTS handset:

1. Turn ON power to the terminal. The signal LED will flash RED.

2. It may take a few minutes for the OC400 terminal to register. If a busy tone is heard ON HOOK wait a few moments before trying again.
3. Lift the RJ11/POTS handset, and listen for a PUK tone. (See "Types of tones on RJ11/POTS" page 25).
4. Enter the PUK on the handset keypad, followed by the # button.
5. Hang up the RJ11/POTS handset and wait for the OC400 terminal to acquire lock and registration.
6. The terminal has now loaded a default PIN of "8888" into the SIM. The OC400 terminal has also DISABLED the SIM PIN requirement on powering up of the terminal.



### NOTE

*If you require to change the SIM PIN from the default PIN, please use the Falcon*

## Operation

### Registration

1. Turn ON power to the terminal. The signal LED will start flashing RED.
2. Wait for the terminal to acquire GPS lock and register to the Inmarsat network. This may take up to 2 minutes.
3. The signal LED will then be solid GREEN or YELLOW and the terminal is ready for calls.



#### NOTE

If your SIM has the PIN enabled, see section "SIM PIN use" page 22, to enter PIN, or to permanently disable PIN. The terminal will not register if PIN is required.

### Prepay subscription balance

If you have a prepay subscription, your service provider will have informed you of the services available to you.

Contact your service provider for details of the dedicated phone number which enables you to make a balance enquiry and redeem prepay vouchers.

### Oceana 400 LED status

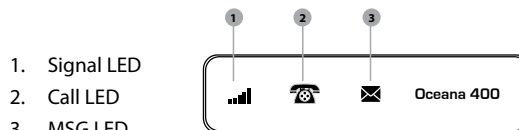

### Oceana 400 LED status table

All LED status lists below exclude error states.

SIGNAL LED	GREEN	RED	YELLOW
ON	Good signal Registered	No signal Registered	Poor signal Registered
FLASHING	Good signal Not registered	No Signal Not registered	Poor signal Not registered
ALTERNATING	Alternating GREEN, YELLOW, RED. Error state entered. The Call and Message LED's indicate the error code.		
MESSAGE LED	GREEN	RED	YELLOW
ON	N/A	N/A	N/A
FLASHING	Voice mail has been received	SMS is present in the inbox	Both a voice mail and inbound SMS has been received
ALTERNATING	N/A	N/A	N/A
CALL LED	GREEN	RED	YELLOW
ON	POTS off-hook	N/A	DTR present on data port
FLASHING	POTS call in progress	N/A	Data call in progress (DCD active)
ALTERNATING	N/A	N/A	N/A

## RJ11/POTS phone use

### Mobile originating

1. Lift the RJ11/POTS phone handset “OFF HOOK” and listen for the dial tone. The call LED will flash GREEN to indicate the RJ11/POTS is in use.
2. Dial (using the full country codes) on the RJ11/POTS telephone keypad.
3. Once the call is connected, the POTS STATUS LED will flash to indicate a call is in progress.
4. Place the RJ11/POTS phone handset “ON HOOK” to terminate the call.

### Mobile terminating

1. The RJ11/POTS phone will sound its ringer.
2. Lift the RJ11/POTS phone handset “OFF HOOK” to answer the call.



*NOTE: (Default operation)*

*For mobile terminated calls, the call will remain active for ~90 seconds even if the RJ11/POTS phone is placed ON HOOK. To end the call immediately, the other calling party must hang up (ON HOOK) the call.*

---

### Data use

Ensure that you have installed the BEAM USB driver – see section “Configuration settings ” (shown on page 21).

The OC400 terminal allows for circuit switched data via the BEAM USB data port that is presented when plugged into your PC.

Follow the normal procedures with your data application to connect. Once connected, the call LED will be flashing YELLOW. Once the circuit switched connection has ended, the call LED will turn off.



*NOTE: During a data connection, the RJ11/POTS handset cannot make or receive voice calls. An unavailable tone will be heard on the RJ11/POTS handset.*

---

### Call Processing on RJ11/POTS phone

Call processing is the ability for the terminal to automatically prefix a users dialled number with the correct area or country code. This is intended to allow for a simpler dialling process for users who have not been trained to place a call from a satellite phone.

The Falcon configuration tool will allow users to enable or disable this feature. By default this feature will be disabled.

When this feature is disabled there will be no alteration to dialled numbers on the RJ11/POTS Phone.

When call processing is enabled the user will be able to customise the following parameters:

- Minimum digits
- Country code
- Area code
- Leading digit for Information numbers
- Leading digit for long distance (STD)
- Dialling emergency number
- Dialling voicemail number
- QUICK DIAL
- ENABLE AUTO DIAL

For further details on these parameters, consult the Falcon configuration tool manual.



## Using voicemail

You will be able to access voicemail messages if your service provider has enabled voicemail. Your terminal automatically checks for voicemails shortly after it has been switched on and connected to the network. It will also send you voicemails that arrive while you are connected to the network.

The message LED will indicate (flashing green or yellow) if you have a new voicemail.

To listen to voicemails dial from the RJ11/POTS phone the short code 570, or the full international number 00 870 772 001 899. Follow the spoken instructions.

You can also specify another short code to access voicemail by enabling the “Call processing” section of the Falcon application.

The default language for voicemail is English, but your service provider may have enabled your voicemail in your chosen language.

If you wish to change the voicemail language, follow the spoken instructions or contact your service provider.

## Using SMS

You will be able to access Short Message Service (SMS) if your service provider has enabled.

The message LED will indicate (flashing red or yellow) if you have SMS messages.

You can read, send, and delete SMS messages by using the Falcon application.

## Error codes

When the signal LED is cycling between GREEN, YELLOW, and RED:

CALL LED	MESSAGE LED	DESCRIPTION/ERROR CODE
GREEN	GREEN	SIM pin required
GREEN	OFF	Insert SIM card
OFF	GREEN	PUK code required
RED	RED	System error
RED	OFF	GPS antenna power error
OFF	RED	SAT antenna power error
RED	GREEN	SIM locked. Contact service provider
GREEN	RED	Wrong SIM Card type. Contact service provider

## Special modes of operation

- Firmware upgrade mode - In firmware upgrade mode all LED's will turn solid YELLOW. Entering this mode will be accompanied by a long beep followed by three short beeps.
- Transceiver (USB Bridge) mode - In this mode all LED's will flash GREEN.

## Types of tones on RJ11/POTS

TYPE OF TONE	SOUND	DESCRIPTION
Dial tone	Continuous tone	Telephone ready for use
Progress tone	Continuous short beep, with 3 second interval	Number has been dialed but call has yet to connect.
Unavailable tone	Beeping tone (engaged)	Phone is not registered, or no signal. Calls cannot be made
SIM PIN required	Alternating low and lower tones (1 sec intervals)	A SIM pin is required to be entered
SIM PUK required	Alternating low and lower tones (2 sec intervals)	A PUK code is required to be entered
Phone off-hook	Fast ascending tone, repeating.	Phone has been left offhook for > 15 seconds and is not in a call.

## Quality of service

There are conditions that can compromise the quality of the service you may receive.

These include:

- Obstructions
- Cabling
- RF Interference

### Obstructions

Nearby tall buildings or similar structures, heavily leafed trees and mountains can all degrade performance as they block the signal between the antenna and the satellites.

Inmarsat performance is immune from natural environments such as clouds, fog, rain, snow, wind and smoke.

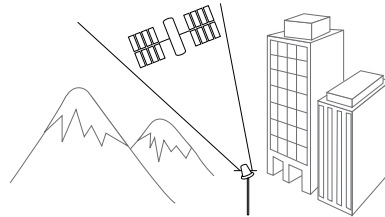
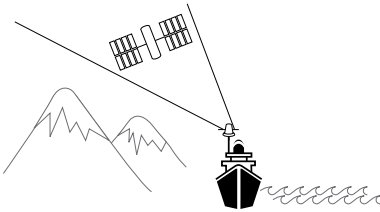

### Cabling

Using an externally mounted antenna provides an ideal solution for many applications. It is very important that both the antenna cabling and antenna are BEAM approved products. Always ensure all RF connectors are screwed together firmly and ensure there are no sharp bends in the cabling between the OC400 and the antenna.

### RF interference

All wireless devices, including satellite telephones, are susceptible to RF (radio frequency) interference from other electronic devices. This problem is more evident when numerous antennas and broadcasting devices are located within close proximity to each other.

### Symptoms of RF interference

Symptoms of RF interference often resemble those that arise when an antenna is being operated with an obstructed view of the sky. Some of these symptoms include; erratic or no signal strength indication dropped calls or warbled or otherwise distorted voice. These symptoms may be intermittent or persistent, depending largely on the interference source, its distance, strength and frequency relative to the antenna.

### Mitigation of RF interference

Service degradation due to RF interference can be significantly improved by:

- Increasing the distance and moving the antenna off axis from the source of the interference, and
- Using an external band pass filter and an external antenna.



### **WARNING**

*Failure to use BEAM approved antenna cables will result in degraded performance and may damage the OC400 terminal. This will void the product warranty.*

## Specification summary

### Electrical & environmental specifications - OC400

Average power consumption (Active antenna connected)	Current @ 15v DC	Power
Standby	0.21A	3.1W
Transmit	0.57A	8.5W
Sleep mode	4mA	60mW
Peak current	1.73A	25.9W
<b>Physical specifications</b>		
Dimensions	240 x 190 x 53 (mm)	8.0 x 7.5 x 2.1 (inches)
Weight	0.58kg	1.28lbs
<b>Environment specifications</b>		
Operating range	-20°C to +55°C	-4°F to +131°F
Storage	-30°C to +80°C	-22°F to +176°F
Humidity	<=75% RH	
<b>Transceiver</b>		
Inmarsat-4 satellite GMR-2+ frequency bands		
Tx operating frequency	1626.5 - 1660.5 MHz	
Rx operating frequency	1518 - 1565 MHz (Inmarsat) 1565.19 - 1585.65 MHz (GPS)	
RF output impedance:	50 Ohms	
Carrier frequencies	Channel 0 = 1626.525 MHz Channel 169 = 1660.475 MHz	
TX modulation	GMSK	
RX modulation	OQPSK	

<b>Connectors / interfaces</b>	
POTS/RJ11	RJ11/2-wire, 5REN @ 600m, adjustable dial, ring, busy tone configured frequency and adaptive impedance.
Antenna	TNC-Female
GPS Antenna	SMA-Female
10-32 V DC	4-way microFit (AC/DC adaptor, or DC lead)
Configuration/data	USB Mini B
<b>Certifications</b>	
Inmarsat Type Approval, FCC, CE Compliance, Electrical Safety, RoHS, Industry Canada, C-Tick	
IP53 Rating 5 = Protected against dust limited ingress (no harmful deposits). 3 = Protected against direct sprays of water up to 60° from the vertical.	
<b>Accessories</b>	
ISD932	IsatDock/Oceana 6m SMA/TNC cable kit (active)
ISD933	IsatDock/Oceana 13m SMA/TNC cable kit (active)
ISD934	IsatDock/Oceana 18m SMA/TNC cable kit (active)
ISD935	IsatDock/Oceana 31m SMA/TNC cable kit (active)
ISD938	IsatDock/Oceana 40m SMA/TNC cable kit (active)
ISD942	IsatDock/Oceana 50m SMA/TNC cable kit (active)
ISD943	IsatDock/Oceana 60m SMA/TNC cable kit (active)
ISD944	IsatDock/Oceana 70m SMA/TNC cable kit (active)
ISD945	IsatDock/Oceana 80m SMA/TNC cable kit (active)
ISD946	IsatDock/Oceana 90m SMA/TNC cable kit (active)
ISD947	IsatDock/Oceana 100m SMA/TNC cable kit (active)
RST060	UPS Battery Pack

<b>Kit contents Oceana 400</b>
Oceana 400 terminal
ISD710 Maritime antenna (active)
110-240V AC plug pack 15v DC out
10-32V DC power cable & USB cable
2 x screws for wall mounting
User manual & Quick Start Guide
Antenna installation guide

## Physical dimensions - OC400

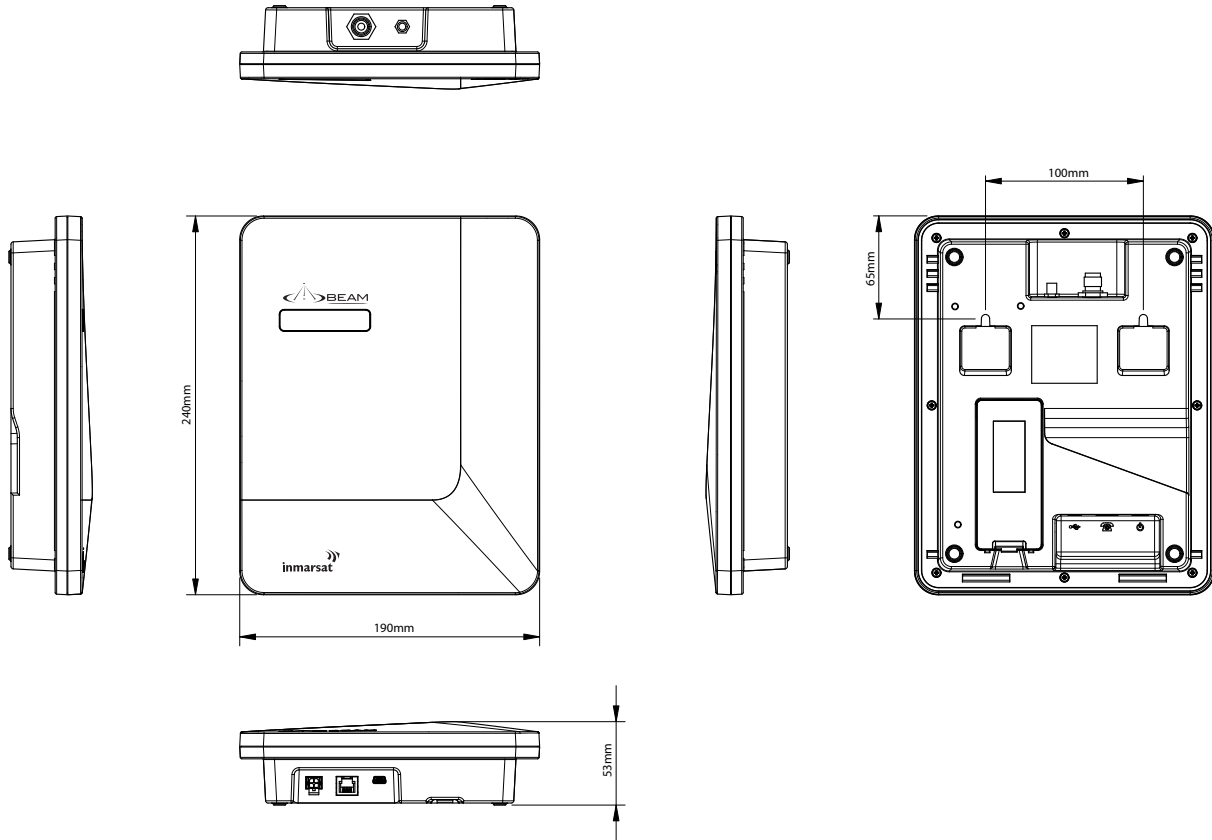

## Troubleshooting

This chapter provides information to help you troubleshoot problems you may encounter while running the OC400.

<b>1</b>	<b>How do I know if my OC400 is registered on the Inmarsat network?</b>
	<i>The signal LED on the terminal will change to GREEN or YELLOW when it is registered and able to make calls on the network.</i>
<b>2</b>	<b>No power on OC400.</b>
	<i>Check power is connected to the interface unit, and fuse ok. Ensure the Connector cable to the OC400 is firmly fitted. Check for short-circuit on antenna cables.</i>
<b>3</b>	<b>The signal LED is flashing and call quality is poor.</b>
	<i>Ensure all antenna connectors are tight. The antenna is operating in a location that it can see the satellite and there are no obstructions. BEAM certified antenna cabling is being used and there are no sharp bends or cuts in the cable. If using a fixed passive antenna, ensure it is orientated correctly and pointing at the satellite.</i>
<b>4</b>	<b>I am looking for the latest manuals and support information for the OC400 terminal?</b>
	<i>Visit: <a href="http://www.beamcommunications.com/Oceana400">http://www.beamcommunications.com/Oceana400</a></i>

<b>5</b>	<b>Dropped calls</b>
	<i>When you are in motion the satellite signal may become obstructed (such as buildings, bridges, tunnels, larger vessels). Check the antenna connection. Ensure the antenna cable has not been damaged. Ensure that only approved antenna cable has been used. Refer to antenna install guide on BEAM website support.</i>
<b>6</b>	<b>The OC400 appears to be turning ON/OFF and is not registering.</b>
	<i>Ensure the power supply can provide at least 3.5A at 12volts. If power is being supplied from a battery, ensure the connections are tight and the contacts are clean. Check for short-circuit on antenna cables.</i>

## Beam Warranty Terms & Conditions

Beam Communications gives this express warranty (along with extended warranty endorsements, where applicable) in lieu of all other warranties, express or implied, including (without limitation), warranties of merchant-ability and fitness for a particular purpose. This constitutes our sole warranty and obligation with regard to our products as well as the Customer's sole remedy.

Beam Communications expressly disclaims all liability and responsibility for any special, indirect or consequential damages or any further loss of any kind whatsoever resulting from the use of our product(s). The Customer's sole and exclusive remedy and the limit of Beam's liability for any loss whatsoever, shall not exceed the purchase price paid by the Customer for the product to which a claim is made.

All products manufactured by Beam Communications are warranted to be free from defects in material and workmanship in accordance with and subject to the following terms and conditions:

1. This warranty is limited to the original Customer only. It cannot be transferred or assigned to third parties unless the intent to transfer to a third party is expressly indicated in a purchase order and/

2. Beam Communications does not warrant any installation, maintenance or service of the Products not performed by Beam, nor does it warrant the use of Products with unapproved ancillary products.
3. Beam Communications will correct any defects in material or workmanship of products manufactured by Beam which appear within twelve (12) months, from the date of shipment by Beam Communications to the Customer. Exception to a 12 months warranty are:

- Units that do not carry a transceiver (24 months warranty)
- Accessories (3 months warranty)

Please note that antennas and products not manufactured by Beam (like; NAL Shout Nano, Man down Kit, RST970, 9522B and 9602) also come with a 12 month warranty.

Beam Communications will repair or replace, at our option, any defective product, provided that our analysis and/or inspection disclose that such defects developed under normal and proper use.

4. This warranty does not extend to goods subjected to liquid or particulate ingress, extreme humidity, misuse, neglect, accident or improper installation, or to maintenance or repair of products that have been altered or repaired by anyone except Beam

Communications unless otherwise stated in writing. If a product has been tampered with (e.g.; warranty seal has been removed, wrong cable has been used with an antenna), the warranty will be void.

5. The warranty is a return-to-base warranty and freight is paid by the sender.
6. A charge of USD\$195.00 including return freight will be made for testing returned product which is not defective or is found to be defective as the result of improper use, maintenance or neglect.
7. Beam Communications will not accept responsibility for any invoiced goods or services that are not covered by a Beam Communications written purchase order. Under no circumstance does Beam Communications agree to pay for labor or other related expenses associated with the troubleshooting and/or repair of our product without prior specific written authorization.
8. Information in our descriptive literature is based on product specifications that are current at the time of publication. Product specifications, designs and descriptive literature are subject to change as improvements are introduced. Although we announce changes as they occur, we cannot guarantee notification to every Customer. Beam Communications warrants delivered product to conform to the most current specifications, designs and descriptive literature.

9. This warranty policy may be expanded or limited, for particular categories of products or Customers, by information sheets published as deemed appropriate by Beam Communications. In particular, the warranty for third party Products is that of the third party and not Beams warranty.

#### **Users in Australia and New Zealand**

This product comes with guarantees that cannot be excluded under the Australian Consumer Law (ACL) and similar legislation in New Zealand. Consumers are entitled to a replacement or refund for a major failure and for compensation for any other reasonably foreseeable loss or damage. Consumers are also entitled to have this product repaired or replaced if the product fails to be of acceptable quality and failure does not amount to a major failure. Please follow the product instructions for correct operation, and report problems promptly; problems caused by use that is abnormal or contrary to instructions will generally not be covered. You should contact your service provider in relation to problems with products and we at Beam will assist your service provider to resolve them, including by replacement where required.

#### **Limitations of Warranty/Local Laws**

This Product is covered by Australian warranty. This Limited Warranty is applicable in all countries and is

enforceable in any country or region where Beam or its reseller offer warranty service for the Product. Outside of Australia, any different warranty terms, liabilities and/or legal requirements of the country in which the Product is sold are specifically disclaimed by Beam. Warranty service availability and response times may vary from country to country and may be subject to registration requirements in the country of purchase. Your Beam reseller can provide details. Your reseller contact details will appear on the sales documentation.

BEAM Communications  
5/8 Anzed Court, Mulgrave  
Victoria, 3170, AUSTRALIA

Tel: +61 3 8588 4500 Fax: +61 3 9560 9055

Web: [www.beamcommunications.com](http://www.beamcommunications.com)  
Info: [info@beamcommunications.com](mailto:info@beamcommunications.com)  
Support: [support@beamcommunications.com](mailto:support@beamcommunications.com)



[www.beamcommunications.com](http://www.beamcommunications.com)