

Wireless Dimming PIR Fixture Mount High/Low Bay Sensor

Overview

- Low Profile PIR sensor
- Mounts in Fixture
- Casambi Wireless Mesh
- High-End Trim, Zoning, Continuous Dimming
- ioXt Alliance cybersecurity certification
- LED Motion indicator
- Active High output for relay drive
- Mounting height up to 40 ft (12.2 m)



Suitable for Indoor only



Applications

The PSC-BL-I-FM-DC0-BLE-CB (standard) uses PIR Motion Detector Architecture and passive infrared (PIR) technology for improved detection coverage for ceiling or fixture mount, high bay, and low bay applications.

The PSC-BL-I-FM-DC0-BLE-CB is a Class 2 Device designed to satisfy CA Title 24 requirements for dimming* of lighting fixtures.

The sensor is suitable for a variety of indoor applications. It supports fixture mounting up to 40 ft (12.2 m) high. Both sensor and power pack are rated for use in temperatures ranging from -30° to 70° C and relative humidity from 90 to 95%.

Accessories

Power Pack: The PSC-BL-I-FM-DC0-BLE-CB operates on 12-24 VDC input and requires a separate power pack such as the McWong PacWave™ PSC-AC-PP-200/400/700C/800/900.

Alternatively, the sensor can operate with a driver that has an auxiliary output (12 V).

*For dim to off, McWong PacWave™ PSC-AC-PP-200/700C/900 Power Pack or LED dimming driver capable of dimming to off is required.

Sensor Operation

Casambi Wireless Mesh Controls: The sensor connects to a wireless mesh network via a mobile app, available as iOS or Android, to allow initial setup and subsequent parameters adjustments.

User Interface: Using the mobile app, features include: setup, control real time feedback, and scheduling without a gateway or internet access.

Dimming: 0-10V dimmer connects to 0-10V control on the LED driver.

Relay Control: An additional High Control output can be used to trigger relays or other control circuitry.

See the McWong Casambi Commissioning User Manual for more information.

Summary

Sensor Type:
PIR occupancy/vaccancy sensor

Input Voltage | Current Consumption:
12-24 VDC | 50 mA

0-10V Output: 150 mA

High: Vin-2.5 V 150 mA source

Mounting Height: - High Bay:
Fixture or ceiling mount up to 40ft (12.2m)
Mounting Height: - Low Bay:
Fixture or ceiling mount up to 30ft (9.1m)

Max Sensor Range: High Bay:
(12.2m) radius
Max Sensor Range Low Bay:
30ft (12.2m) radius

Max Wireless Range¹
100ft (30.4m)

Operating Temperature:
-30° C to 70°C

Storage Temperature:
-40° C to 80°C

Relative Humidity:
90-95% non-condensing at 30°C

Color: White

Warranty: 5 years

Note:
1. Wireless Range is highly dependent on the integration of fixtures, surrounding environment and conditions. It is recommended to conduct testing for range accuracy.

Project

Location/Type

Physical Dimensions

Standard Housing

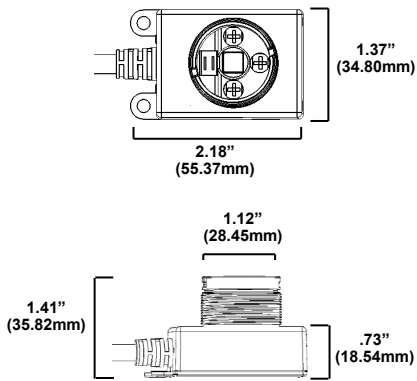

Lens Cover

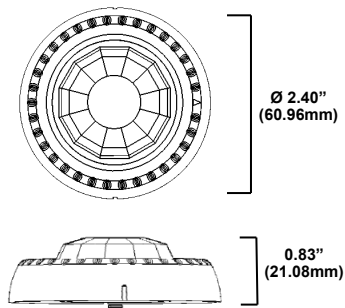

Drawings are Not to Scale

Installation

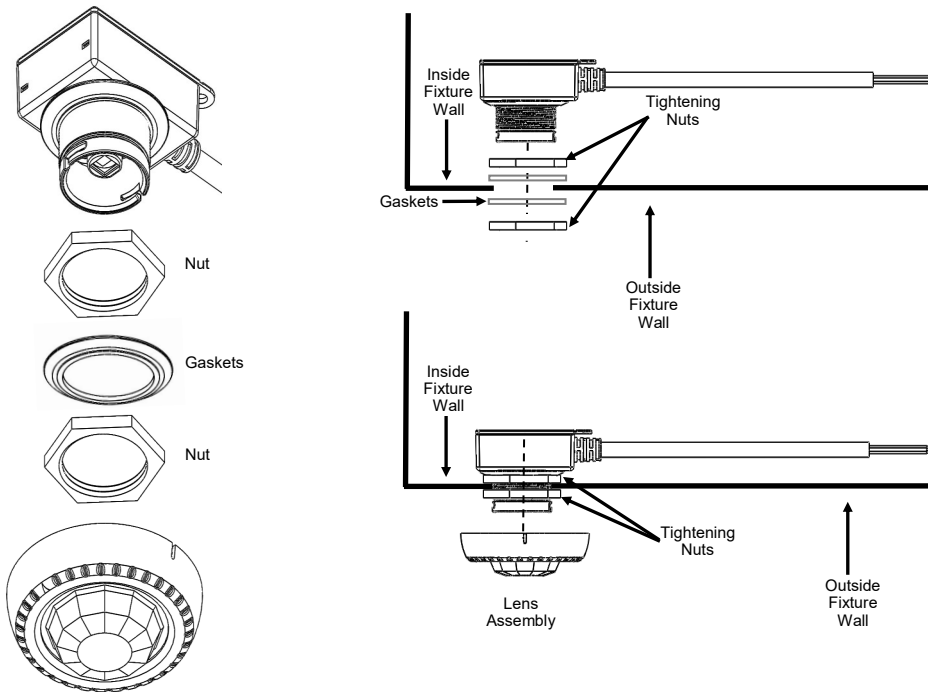

Wiring Diagram and Fixture Mount

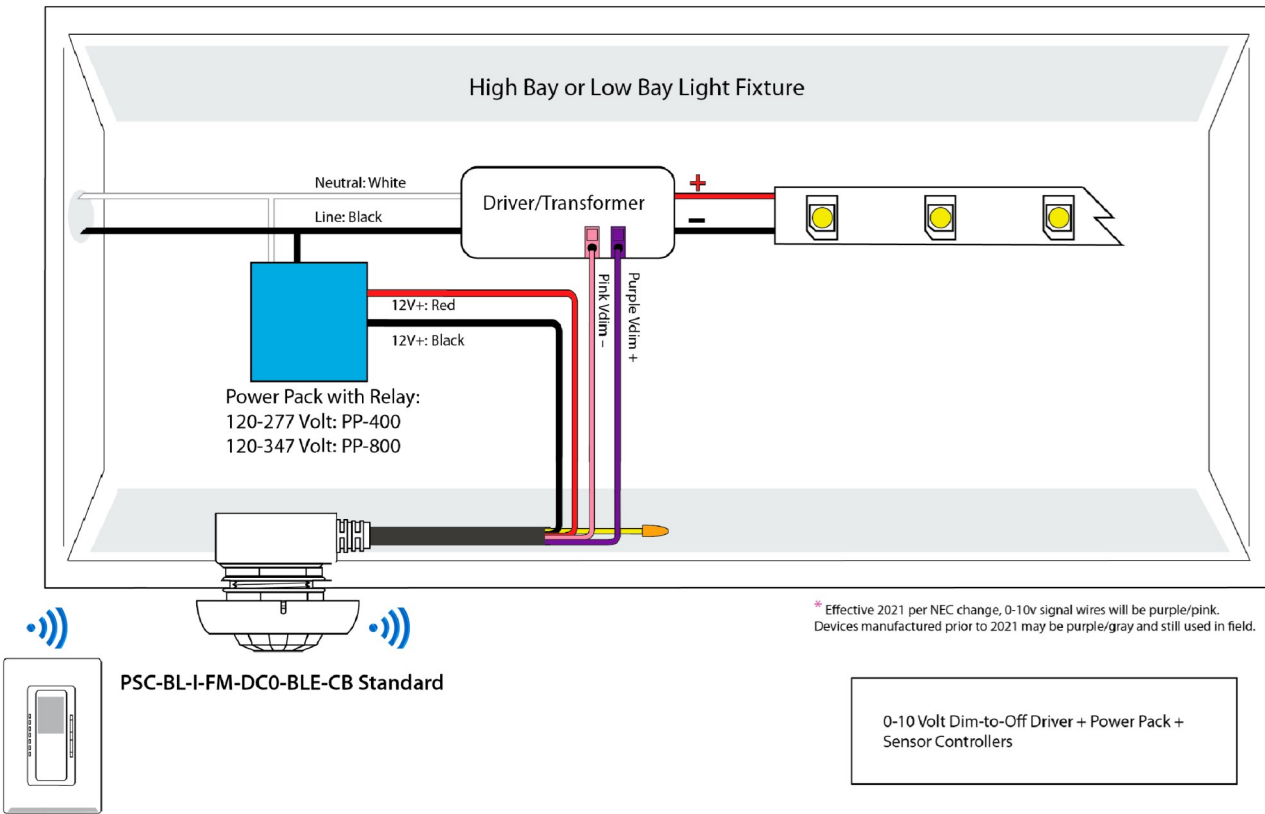

Dim to Off Driver with 12v Auxiliary Power

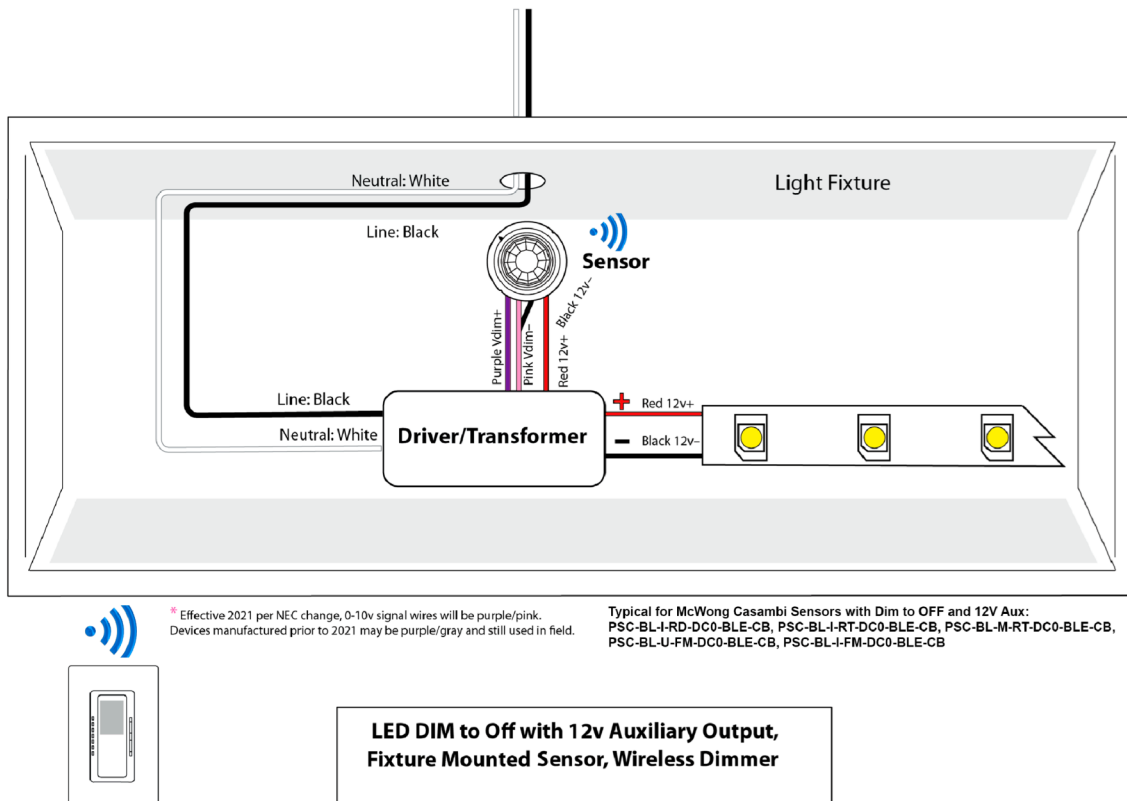

Detection Area Lens Orientation



Fresnel Lens:
 Lenses are available in:
 Low Bay Lens for mounting height
 at 8-30 ft (2.4-9.1 m),
 High Bay Lens for mounting height
 at 20-40 ft (6.1-12.2 m).

Detection Area

HBL: High Bay Lens-Top View at 8

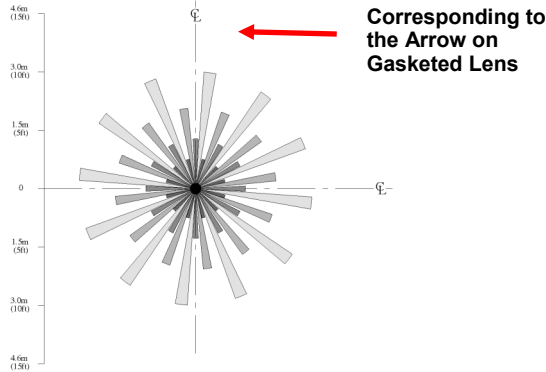

HBL - Side View

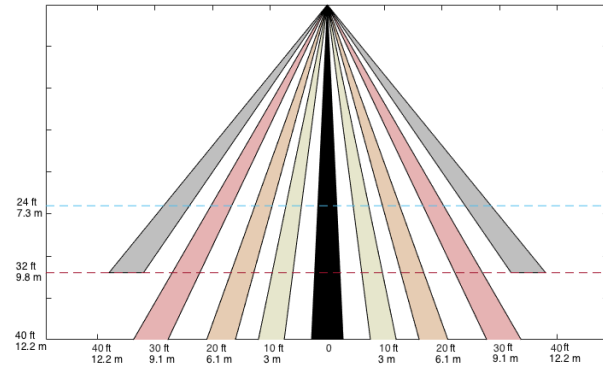

LBL: Low Bay Lens-Top View at 8 ft

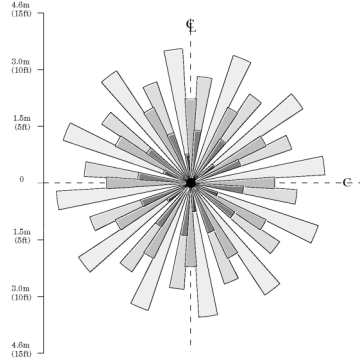

LBL - Side View

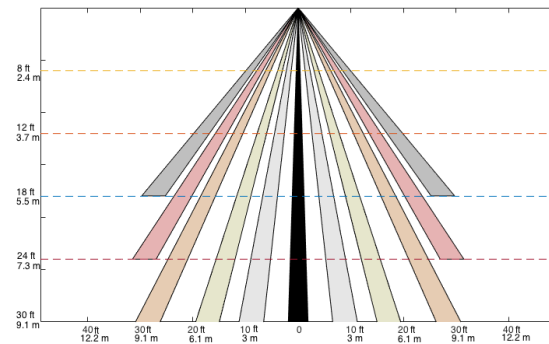

How to Order

Model No.	Description	Input Voltage	Output
PSC-BL-I-FM-DC0-BLE-CB	Passive Infrared (PIR) Occupancy Sensor, with Casambi Wireless Mesh	12-24VDC	0-10VDC Control High Control Low
PIR-BL01-F3-LBL	360° Low Bay Lens, maximum coverage 60ft diameter at 30ft height, White Color		
PIR-BL01-F3-LBL-BN	360° Low Bay Lens, maximum coverage 60ft diameter at 30ft height, Brown Color		
PIR-BL01-F5-HBL	360° High Bay Lens, maximum coverage 70ft diameter at 40ft height or 80ft diameter at 32ft height, White Color		
PIR-BL01-F5-HBL-BN	360° High Bay Lens, maximum coverage 70ft diameter at 40ft height or 80ft diameter at 32ft height, Brown Color		

For Line to Low Voltage Power Supply/Controller, please check McWong PacWave™ PSC-AC-PP-200/300/400/700C/800/900.
 Design and specifications are subject to change without notice.