



## FLANGED ELEMENT REPLACEMENT INSTRUCTIONS



**ELEMENT CHART**

Model	Replaces Models	KW
12-0010F-K	12-0010A-K, 25-1470-1	5.5KW
12-0011F-K	12-0010-K	4.5KW
12-0012F-K		4.0KW
12-0014F-K		3.0KW
12-0016F-K		2.0KW

**ATTENTION!** This product should be installed by a qualified electrician or pool/spa technician. If you're not qualified or do not have the technical skill to install this product correctly **STOP!** And contact your local spa repair professional.

**⚠ WARNING!** Damaging product by altering, bending, drilling, subjecting to chemical corrosion or wet /dry fire will void product warranty.

### **STEPS FOR A SUCCESSFUL INSTALLATION**

1. Read through complete instructions before performing work.
2. Inspect for shipping/handling damage. **Do Not install a product that appears to be damaged.**
3. Using the data label, confirm the new element has the same kW value as the element being removed.  
 ➡ **Stop and contact your element supplier if you have the incorrect part.**
4. Turn spa thermostat to the "OFF" position and shut power "OFF" at spa breaker. Drain spa water or isolate the heater plumbing so spa water will not drain.
5. Remove the bad element and note direction of the high limit switch and location of wire connections.
7. Clean and inspect heater housing O-ring surface, nuts, washers, bolts, and high limit devices to be reused.

## DIA #1

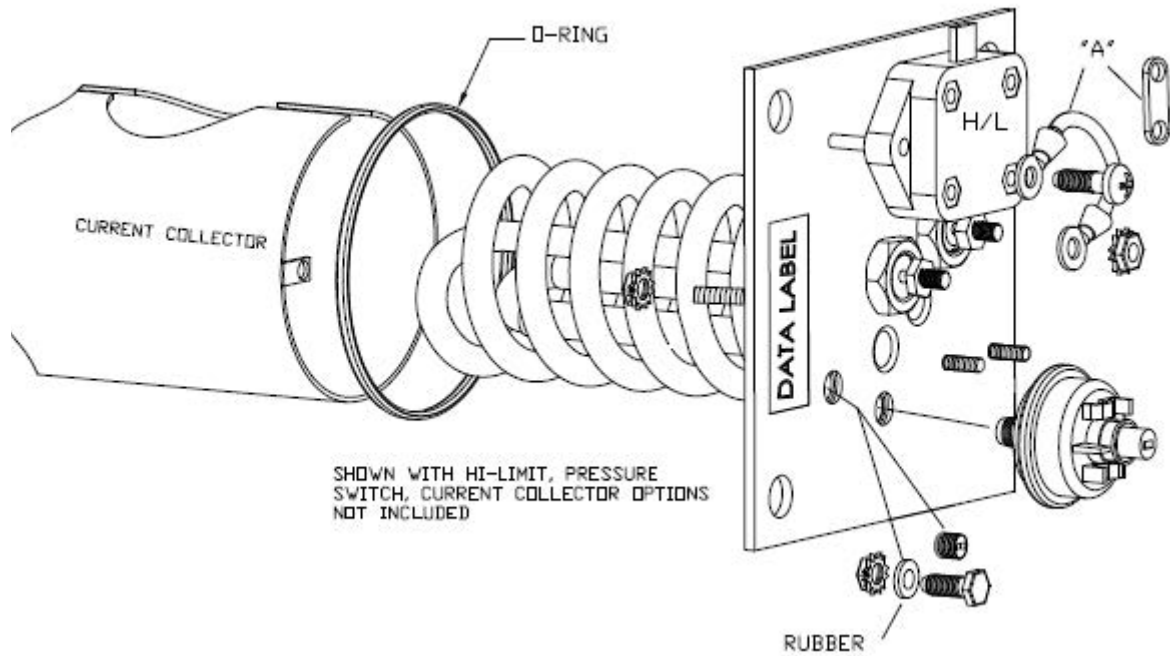

- 8.** Install element and tighten mounting bolts in a harmonic pattern until O-ring is compressed (O-ring lube recommended).
- 9.** Reconnect wires to element terminals using a backup wrench to prevent damage to terminals (Ref DIA #2).
- 10.** Jumper wire "A" replaces the metal bridge connectors.
- 11.** Install threaded plug or bolt depending on heater model. Provided plugs have dry sealant applied to threads.
- 12.** Complete installation, refill spa, turn on breaker, and inspect for leaks with pump at high speed.

## DIA #2

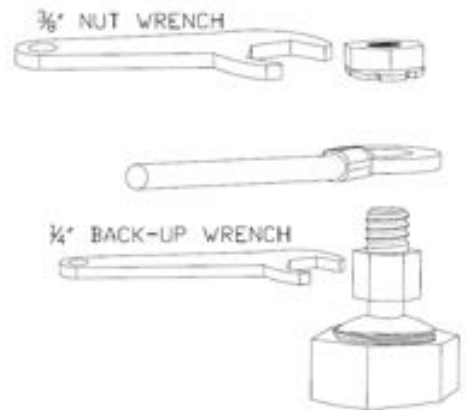

**⚠ WARNING!** Never allow the element/heater to operate without water flow

## WARRANTY GUIDELINES

All warranty claims and product returns must be handled through your element provider (no exceptions). Product returns determined to have shipping or installation damage, alteration, signs of chemical corrosion, or evidence of wet/dry fire or abuse, will not be considered for warranty.