

## Technical guide

**VITODENS 200-W** Type B2HA**Wall mounted gas condensing boiler**With modulating MatriX cylinder burner for natural gas and  
LPG

For open flue or room sealed operation

## Index

<b>1. Vitodens 200-W</b>	1.1 Product description .....	4
	1.2 Specification for the Vitodens 200-W, 49 and 60 kW .....	7
	1.3 Specification for the Vitodens 200-W, 80 and 99 kW .....	13
	1.4 Specification for the Vitodens 200-W, 120 and 150 kW .....	20
<b>2. Installation accessories</b>	2.1 Installation accessories for Vitodens 200-W, 49 and 60 kW .....	28
	■ Heating circuit connection set with variable speed high efficiency circulation pump and low loss header .....	28
	■ Connection set for heating circuit without circulation pump for combination with external system separation or heating water buffer cylinder .....	28
	■ DHW cylinder connection set .....	28
	■ Connection set for combination of Vitodens 200-W with CHP unit .....	29
	■ Connection accessories for installation to the left/right .....	29
	■ Connection accessories for installation to the top/bottom .....	29
	■ Dual sensor well for combination of Vitodens 200-W with heat pump .....	30
	■ Wall mounting bracket .....	30
	■ Mounting frame .....	30
	■ Immersion temperature sensor (for low loss header) .....	31
	■ CO limiter .....	31
	2.2 Installation accessories for Vitodens 200-W, 80 and 99 kW .....	32
	■ Heating circuit connection set with variable speed high efficiency circulation pump and low loss header .....	32
	■ Connection set for heating circuit with high efficiency circulation pump for combination with external system separation or heating water buffer cylinder .....	32
	■ DHW cylinder connection set .....	32
	■ Connection set for combination of Vitodens 200-W with CHP unit .....	33
	■ Connection accessories for installation to the left/right .....	33
	■ Connection accessories for installation to the top/bottom .....	33
	■ Dual sensor well for combination of Vitodens 200-W with heat pump .....	34
	■ Wall mounting bracket .....	34
	■ Mounting frame .....	34
	■ Immersion temperature sensor (for low loss header) .....	35
	■ CO limiter .....	35
	2.3 Installation accessories for Vitodens 200-W, 120 and 150 kW .....	36
	■ Heating circuit connection set with variable speed high efficiency circulation pump and low loss header .....	36
	■ Connection set for heating circuit with high efficiency circulation pump for combination with external system separation or heating water buffer cylinder .....	36
	■ DHW cylinder connection set .....	36
	■ Connection set for combination of Vitodens 200-W with CHP unit .....	37
	■ Connection accessories for installation to the left/right .....	37
	■ Connection accessories for installation to the top/bottom .....	37
	■ Dual sensor well for combination of Vitodens 200-W with heat pump .....	38
	■ Wall mounting bracket .....	38
	■ Mounting frame .....	38
	■ Immersion temperature sensor (for low loss header) .....	39
	2.4 Divicon heating circuit distributor .....	40
	■ Cable set with plugs 40 and 145 .....	49
	■ Wall mounting bracket for individual Divicons .....	50
	■ Manifold for 2 Divicons .....	50
	■ Manifold for 3 Divicons .....	50
	■ Wall mounting bracket for manifold .....	51
	2.5 Installation accessories for multi boiler systems .....	52
	■ Hydraulic cascades .....	52
	■ Flue gas cascades (positive pressure) .....	53
<b>3. DHW cylinders</b>	3.1 Product description .....	54
<b>4. Design information</b>	4.1 Siting, installation .....	54
	■ Siting conditions for open flue operation (appliance type B) .....	54
	■ Siting conditions for room sealed operation (appliance type C) .....	55
	■ Operation of the Vitodens in wet rooms .....	56
	■ Electrical connection .....	57
	■ Gas connection .....	58
	■ Minimum clearances .....	58
	■ Wall mounting the Vitodens 200-W, 49 to 99 kW (single boiler) .....	58
	■ Wall mounting the Vitodens 200-W, 120 to 150 kW (single boiler) .....	60
	■ Installation with mounting frame, Vitodens 200-W, 49 to 150 kW (single boiler) .....	62
	■ Multi boiler system .....	63

4.2	Condensate connection .....	77
■	Condensate drain pipe and neutralisation .....	78
4.3	Hydraulic connection .....	81
■	General .....	81
■	Expansion vessels .....	83
■	Multi boiler systems .....	83
■	Max./min. flow rates Vitodens 200-W .....	83
4.4	Intended use .....	84
<b>5.</b>	<b>Control units</b>	
5.1	Vitotronic 100, type HC1B constant temperature control unit .....	84
■	Layout and functions .....	84
■	Specification Vitotronic 100, type HC1B .....	85
5.2	Vitotronic 200, type HO1B weather-compensated control unit .....	85
■	Design and functions .....	85
■	Specification Vitotronic 200, type HO1B .....	87
5.3	Vitotronic 300-K, type MW2B for multi boiler systems .....	88
■	Cascade control unit for Vitodens 200-W with Vitotronic 100 .....	88
■	Design and function .....	88
■	Specification, Vitotronic 300-K .....	90
■	Delivered condition Vitotronic 300-K .....	91
5.4	Accessories for the Vitotronic .....	91
■	Allocation to control unit types .....	91
■	Vitotrol 100, type UTA .....	92
■	Vitotrol 100, type UTDB .....	92
■	External H4 extension .....	93
■	Vitotrol 100, type UTDB-RF .....	93
■	Notes regarding room temperature hook-up (RS function) for remote control units .....	94
■	Information on the Vitotrol 200-A and Vitotrol 300-A .....	94
■	Vitotrol 200-A .....	94
■	Vitotrol 300-A .....	95
■	Information on Vitotrol 200-RF .....	95
■	Vitotrol 200-RF .....	95
■	Wireless base station .....	96
■	Wireless repeater .....	96
■	Room temperature sensor .....	97
■	Immersion temperature sensor .....	97
■	Immersion temperature sensor .....	97
■	KM BUS distributor .....	98
■	Mixer extension kit with integral mixer motor .....	98
■	Mixer extension kit for separate mixer motor .....	99
■	Vitotronic 300-K extension for heating circuits 2 and 3 with mixer .....	99
■	Mixer extension kit in conjunction with Divicon heating circuit distributor .....	99
■	Extension kit for one heating circuit with mixer for Vitotronic 300-K .....	100
■	Immersion temperature limiter .....	100
■	Contact temperature limiter .....	101
■	Solar control module, type SM1 .....	101
■	Internal H1 extension .....	102
■	Internal H2 extension .....	103
■	AM1 extension .....	103
■	EA1 extension .....	103
■	Vitocom 300, type LAN3 .....	104
■	LON connecting cable for data exchange between control units .....	106
■	Extension of the connecting cable .....	106
■	Terminators (2 pce) .....	106
■	LON communication module .....	106
■	Vitoconnect 100, type OPTO2 .....	107
<b>6.</b>	<b>Appendix</b>	
6.1	Regulations / Directives .....	108
■	Regulations and directives .....	108
<b>7.</b>	<b>Keyword index</b>	109

## 1.1 Product description

Vitodens 200-W, 49 to 60 kW



- Ⓐ Inox-Radial heat exchangers made from stainless steel – for high operational reliability and a long service life. High heating output on the smallest of footprints
- Ⓑ Modulating Matrix cylinder burner for extremely low emissions and quiet operation
- Ⓒ Variable speed combustion air fan for quiet and economical operation
- Ⓓ Gas and water connections
- Ⓔ Digital boiler control unit

## Vitodens 200-W (cont.)

### Vitodens 200-W, 80 to 99 kW



- Ⓐ Inox-Radial heat exchangers made from stainless steel – for high operational reliability and a long service life. High heating output on the smallest of footprints
- Ⓑ Modulating MatriX cylinder burner for extremely low emissions and quiet operation
- Ⓒ Variable speed combustion air fan for quiet and economical operation
- Ⓓ Gas and water connections
- Ⓔ Digital boiler control unit

### Vitodens 200-W, 120 to 150 kW

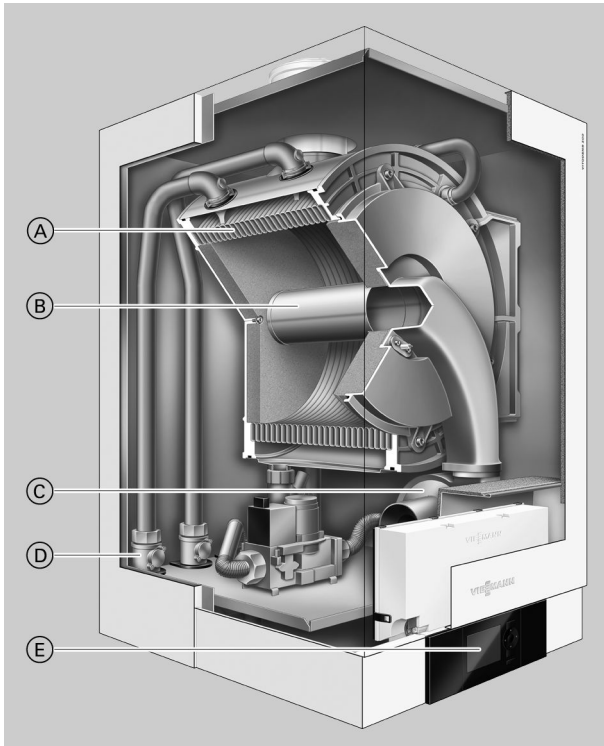

- Ⓐ Inox-Radial heat exchangers made from stainless steel – for high operational reliability and a long service life. High heating output on the smallest of footprints.
- Ⓑ Modulating MatriX cylinder burner for extremely low emissions and quiet operation
- Ⓒ Variable speed combustion air fan for quiet and economical operation
- Ⓓ Gas and water connections
- Ⓔ Digital boiler control unit

### Product information

The Vitodens 200-W wall mounted condensing boilers with outputs up to 150 kW are especially suitable for installation in apartment buildings and commercial or public buildings. In these settings, the Vitodens 200-W offers affordable, space saving solutions – either as a single appliance up to 150 kW or as a cascade with up to 6 boilers and a heating output up to 594 kW.

The Inox-Radial heat exchanger made from stainless steel offers high output in the tightest of spaces. This enables particularly efficient operation with standard seasonal efficiency [to DIN] of up to 98 % (H<sub>s</sub>) [gross cv].

The Vitotronic 300-K cascade control unit regulates up to 6 Vitodens 200-W as a single heating centre. The output of the boilers is automatically matched to the heat demand. This means that, subject to the prevailing heat demand, only one boiler modulates or all 6 boilers operate concurrently.

We offer the complete range of matching system technology for creating cascade systems: Control units, fully insulated hydraulic cascades and flue gas collectors.

### Recommended applications

High heating output in a compact, neat wall mounted appliance, suitable for the following areas of application:

- Systems with few, large-demand consumers, e.g. fan heaters in supermarkets/shopping centres, workshops and industrial premises, commercial nurseries, garages and DHW heating systems
- Systems with several heating circuits for underfloor and/or static heating surfaces in apartment buildings, central heating plants for terraced houses, office and administration buildings – particularly suitable as attic heating centres
- Heating of public buildings such as sports halls, multi-purpose halls, schools, kindergartens
- Suitable for installation in basement plant rooms, on single floors or under the roof.

### Benefits at a glance

- Optional cascade installation with up to 6 boilers and up to 594 kW rated heating output
- Standard seasonal efficiency [to DIN]: Up to 98 % (H<sub>s</sub>) [gross cv]
- Durable and efficient thanks to Inox-Radial heat exchanger
- Modulating MatriX cylinder burner with a long service life thanks to stainless steel MatriX gauze – resistant to high temperature loads
- Easy to operate Vitotronic control unit with plain text and graphic display
- Lambda Pro Control combustion controller for all gas types – saves on costs by extending the inspection interval to 3 years
- Quiet operation thanks to low fan speed
- Web-enabled through Vitoconnect (accessories) for operation and service via Viessmann apps

### Delivered condition

- Wall mounted gas condensing boiler with Inox-Radial heat exchanger, modulating MatriX cylinder burner for natural gas and LPG to DVGW Code of Practice G260 [Germany] and wall mounting bracket.
- Fully plumbed and wired. Colour of the epoxy-coated casing: White.

- Packed separately:
- Vitotronic 100 for constant temperature operation or Vitotronic 200 for weather-compensated operation.
- Preset for operation with natural gas. Conversion within gas groups E/LL is not required. The conversion to LPG is made at the gas solenoid valve (a conversion kit is not required).

### Multi boiler systems

Multi boiler systems for open flue operation with 2, 3, 4, 5 or 6 boilers.

### Inline formation with a pre-plumbing jig (wall mounted)

Comprising:

- Cascade module for each boiler with:
  - High efficiency circulation pump
  - Ball valves
  - Drain & fill valve
  - Gas shut-off valve
  - Safety valve
  - Thermal insulation
- Vitotronic 300-K weather-compensated digital cascade and heating circuit control unit
- Cascade communication module for each boiler
- Pre-plumbing jig

### Inline and block formation with a mounting frame

Comprising:

- Cascade module for each boiler with:
  - High efficiency circulation pump
  - Ball valves
  - Drain & fill valve
  - Gas shut-off valve
  - Safety valve
  - Thermal insulation
- Vitotronic 300-K weather-compensated digital cascade and heating circuit control unit
- Cascade communication module for each boiler
- Mounting frame

### Note

*Order circulation pumps for heating circuits and cylinder heating separately.*

### Tested quality



CE designation according to current EC Directives



ÖVGW Quality Mark for gas and water equipment

## 1.2 Specification for the Vitodens 200-W, 49 and 60 kW

Gas boiler, type B and C, category II <sub>2N3P</sub>		Gas condensing system boiler	
<b>Rated heating output range when operating with natural gas</b>			
Details to EN 15502-1			
- T <sub>F</sub> /T <sub>R</sub> = 50/30 °C	kW	12.0 to 49.0	12.0 to 60.0
- T <sub>F</sub> /T <sub>R</sub> = 80/60 °C	kW	10.9 to 45.0	10.9 to 55.2
<b>Rated heating output range when operating with LPG P</b>			
Details to EN 15502-1			
- T <sub>F</sub> /T <sub>R</sub> = 50/30 °C	kW	17.0 to 49.0	17.0 to 60.0
- T <sub>F</sub> /T <sub>R</sub> = 80/60 °C	kW	15.5 to 45.0	15.5 to 55.2
<b>Rated heat input</b>			
- For operation with natural gas	kW	11.2 to 45.7	11.2 to 56.2
- For operation with LPG P	kW	16.1 to 45.7	16.1 to 56.2
<b>Type</b>		B2HA	B2HA
<b>Product ID</b>		CE-0085CN0050	
<b>IP rating</b>		IP X4 to EN 60529	
<b>Gas supply pressure</b>			
- Natural gas	mbar	20	20
	kPa	2	2
- LPG	mbar	50	50
	kPa	5	5
<b>Max. perm. gas supply pressure<sup>*1</sup></b>			
- Natural gas	mbar	25.0	25.0
	kPa	2.5	2.5
- LPG	mbar	57.5	57.5
	kPa	5.75	5.75
<b>Sound power level (to EN ISO 15036-1)</b>			
- Partial load	dB(A)	39	39
- Rated heating output	dB(A)	58	67
<b>Power consumption (delivered condition)</b>	W	62	115
<b>Weight</b>	kg	65	65
<b>Heat exchanger capacity</b>	l	7.0	7.0
<b>Max. flow temperature</b>	°C	76	76
<b>Max. flow rate</b>	l/h	3500	3500
Limit for the use of hydraulic separation			
<b>Nominal circulating water volume at T<sub>F</sub>/T<sub>R</sub> = 80/60 °C</b>	l/h	1748	2336
<b>Permiss. operating pressure</b>	bar	4	4
	MPa	0.4	0.4
<b>Dimensions</b>			
- Length	mm	380	380
- Width	mm	480	480
- Height	mm	850	850
<b>Gas connection</b>		R ¾	R ¾
<b>Supply values (relative to the max. load)</b>			
- Natural gas E	m <sup>3</sup> /h	4.84	5.95
- Natural gas LL	m <sup>3</sup> /h	5.62	6.91
- LPG	kg/h	3.57	4.39

\*1 If the gas supply pressure is higher than the maximum permissible value, install a separate gas pressure governor upstream of the system.

## Vitodens 200-W (cont.)

Gas boiler, type B and C, category II <sub>2N3P</sub>		Gas condensing system boiler	
<b>Rated heating output range when operating with natural gas</b>			
<b>Details to EN 15502-1</b>			
– T <sub>F</sub> /T <sub>R</sub> = 50/30 °C	kW	12.0 to 49.0	12.0 to 60.0
– T <sub>F</sub> /T <sub>R</sub> = 80/60 °C	kW	10.9 to 45.0	10.9 to 55.2
<b>Flue gas parameters<sup>*2</sup></b>			
Flue gas category to G 635/G 636		G <sub>52</sub> /G <sub>51</sub>	G <sub>52</sub> /G <sub>51</sub>
Temperature (at a return temperature of 30 °C)			
– Rated heating output	°C	62	66
– Partial load	°C	39	39
Temperature (at a return temperature of 60 °C)			
	°C	75	80
<b>Mass flow rate</b>			
Natural gas			
– Rated heating output	kg/h	78	104
– Partial load	kg/h	30	30
LPG			
– Rated heating output	kg/h	74	99
– Partial load	kg/h	28	28
Available draught <sup>*11</sup>	Pa	250	250
	mbar	2.5	2.5
<b>Max. amount of condensate</b>			
– To DWA-A 251	l/h	6.3	8.4
<b>Condensate connection (hose nozzle)</b>	Ø mm	20-24	20-24
<b>Flue gas connection</b>	Ø mm	80	80
<b>Ventilation air connection</b>	Ø mm	125	125
<b>Standard seasonal efficiency [to DIN] at</b>			
– T <sub>F</sub> /T <sub>R</sub> = 40/30 °C	%	Up to 98 (H <sub>s</sub> ) [gross cv]	
<b>Energy efficiency class</b>		A	A
<b>Seasonal space heating energy efficiency<sup>*4</sup></b>		η <sub>s</sub> (%)	94

### Multi boiler systems

For further details regarding multi boiler systems, see page 63.

<sup>\*2</sup> Calculation values for sizing the flue system to EN 13384.

Flue gas temperatures as actual gross values at 20 °C combustion air temperature.

The flue gas temperature at a return temperature of 30 °C is significant for the sizing of the flue system.

The flue gas temperature at a return temperature of 60 °C is used to determine the application range of flue pipes with maximum permissible operating temperatures.

<sup>\*11</sup> CH: Available draught 200 Pa; 2.0 mbar

<sup>\*4</sup> Figure for the appliance only (without control unit). For the final seasonal room heating energy efficiency figure, the system label must be calculated.



## Vitodens 200-W (cont.)

With heating circuit connection set with low loss header

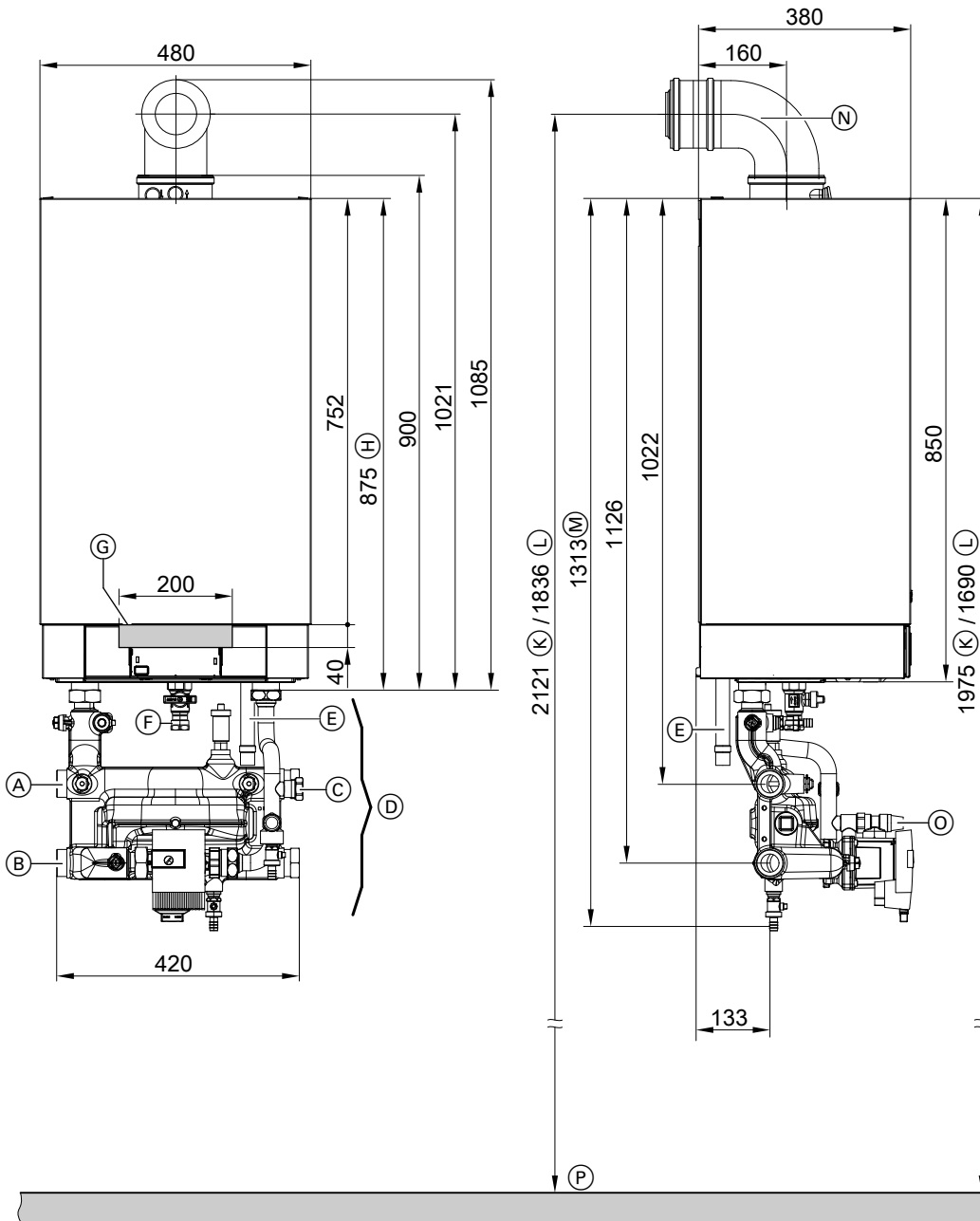

- (A) Heating flow G 1½ (male thread) (connection possible to the left or to the right)
- (B) Heating return G 1½ (male thread) (connection possible to the left or to the right)
- (C) Expansion vessel connection G 1 (male thread)
- (D) Heating circuit connection set with integral low loss header, shown without thermal insulation (standard delivery)
- (E) Condensate drain
- (F) Gas connection Rp ¾

- (G) Area for insertion of electrical cables at the back
- (H) Without connection sets
- (K) Recommended dimension for single boiler system
- (L) Recommended dimension for multi boiler system
- (M) With connection sets
- (N) Balanced flue bend (accessories)
- (O) Safety valve  
(PL/IT: Without safety valve)
- (P) Top edge of finished floor

### Note

- A heating circuit connection set **must** be ordered separately.
- Lay all required power cables on site and route them into the boiler in the specified area.

When balancing the low loss header, adjust the flow rate on the boiler side (V primary (A)) to approx. 10 to 30 % below the flow rate on the system side (V secondary (B)) (return temperature reduction). The low loss header separates the heat generator circuit (boiler circuit) from the following heating circuits.

5822432

### Operating principle of the low loss header

The low loss header integrated into the heating circuit connection set is sized for the max. flow rate which may occur in the overall system.

## Vitodens 200-W (cont.)

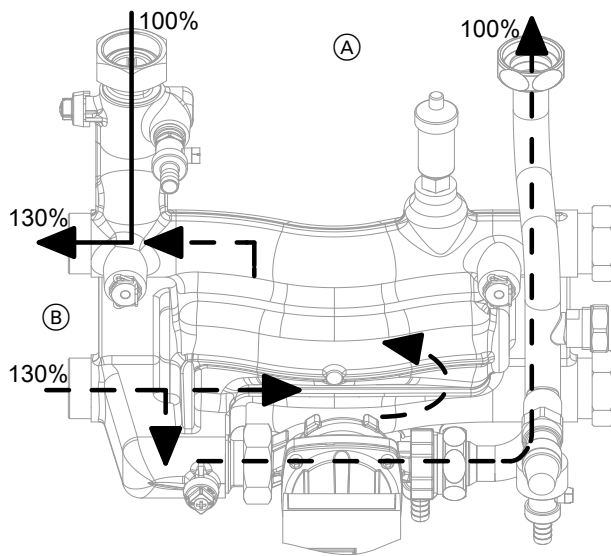

- (A) V primary
- (B) V secondary

### High efficiency circulation pump in the heating circuit connection set

The HE circulation pump consumes significantly less power than conventional pumps.

By matching the pump rate of the circulation pump to the individual system conditions, the power consumption of the heating system is reduced.

#### Circulation pump VI Para MAXO 25-130/11 (0 to 10 V)

<b>Rated voltage</b>	V~	230
<b>Power consumption</b>		
– max.	W	140
– min.	W	8

### Adjust the functioning of the primary side circulation pump during commissioning

Hydraulic connection/connection requirements	Control unit setting Coding address/group	Circulation pump setting (recommendation)
Single boiler system Connection of heating circuits with connection set with integral low loss header <b>Circulation pump VI Para MAXO 25-130/11</b>	30:0/boiler/2	 $\Delta p-c$ – 49 kW at $\Delta t = 15\text{ K} \rightarrow \dot{V} \approx 2.87\text{ m}^3/\text{h}$ – 60 kW at $\Delta t = 17\text{ K} \rightarrow \dot{V} \approx 3.37\text{ m}^3/\text{h}$

### Pressure drop on the heating water side

For sizing a cylinder loading pump (on site).

For DHW cylinder connection set for connecting the DHW cylinder upstream of the low loss header, see accessories.

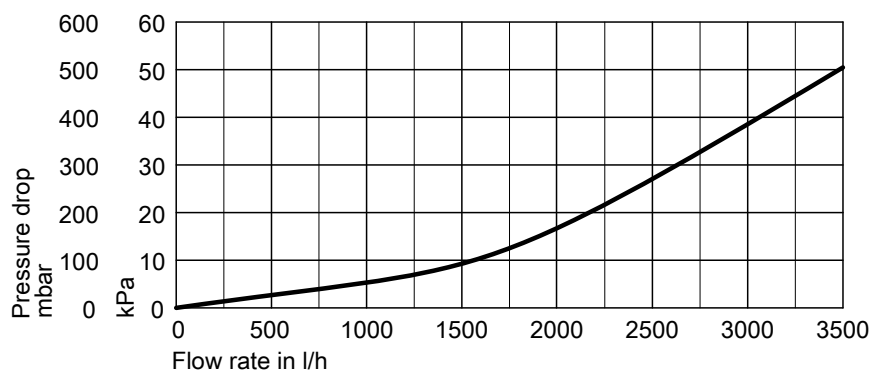

### Note

If operating the heating circuit pump and circulation pump for cylinder heating in parallel (no DHW priority control), we recommend installing the DHW cylinder in the secondary side of the heating system.

## Vitodens 200-W (cont.)

With heating circuit connection set for combination with system separation or heating water buffer cylinder

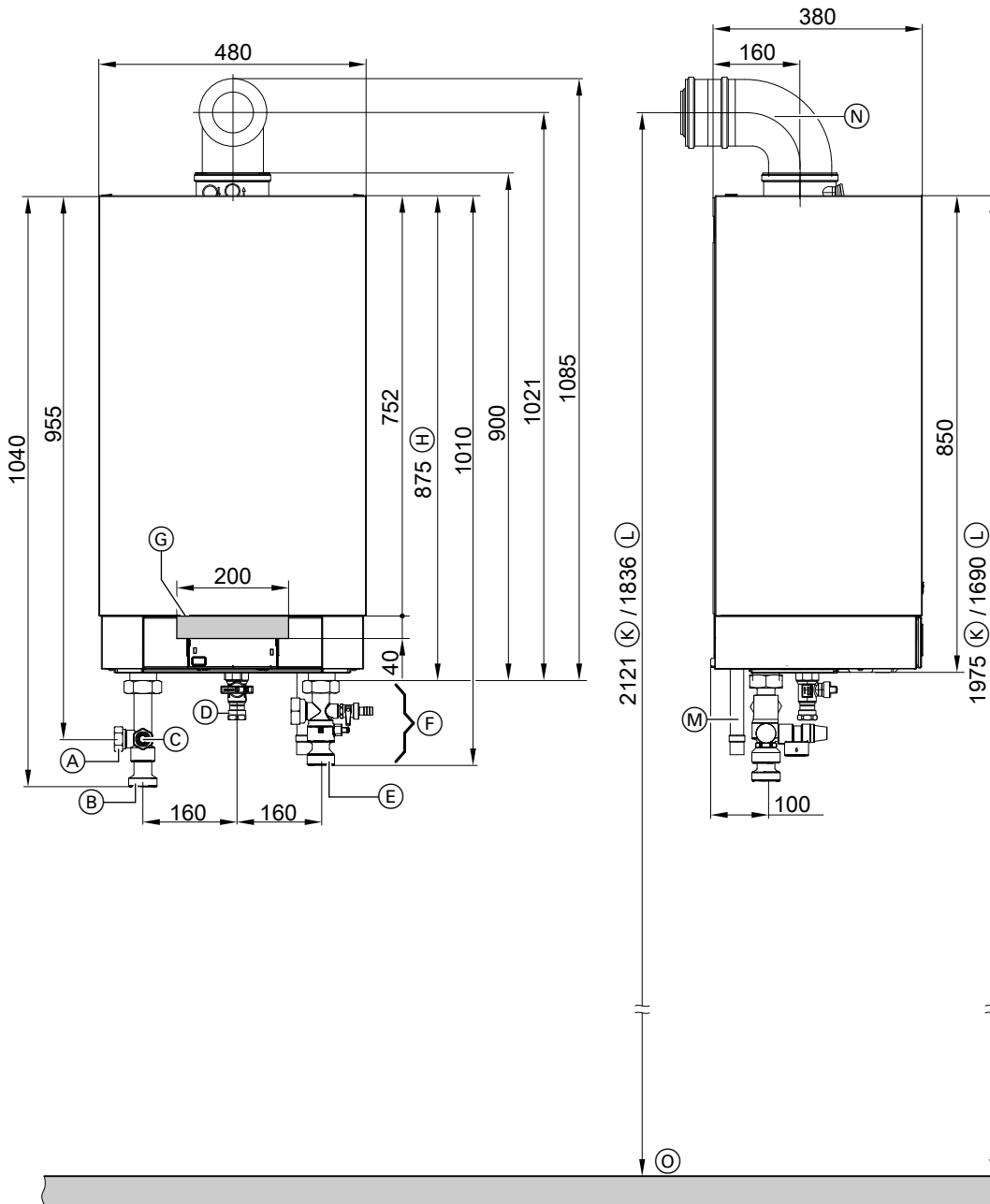

- (A) Expansion vessel connection G 1 (male thread)
- (B) Heating flow G 1½ (male thread)
- (C) Safety valve
- (D) Gas connection Rp ¾
- (E) Heating return G 1½ (male thread)
- (F) Heating circuit connection set

- (G) Area for insertion of electrical cables at the back
- (H) Without connection sets
- (K) Recommended dimension for single boiler system
- (L) Recommended dimension for multi boiler system
- (M) Condensate drain
- (N) Balanced flue bend (accessories)
- (O) Top edge of finished floor

## Vitodens 200-W (cont.)

### Note

- A heating circuit connection set **must** be ordered separately.
- Lay all required power cables on site and route them into the boiler in the specified area.

### Pressure drop on the heating water side

For sizing a circulation pump (accessories or on site).

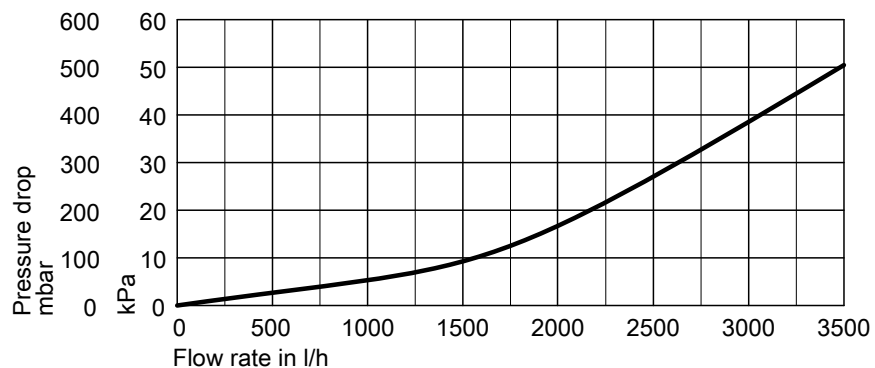

### Note

If operating the heating circuit pump and circulation pump for cylinder heating in parallel (no DHW priority control), we recommend installing the DHW cylinder in the secondary side of the heating system.

**1.3 Specification for the Vitodens 200-W, 80 and 99 kW**

Gas boiler, type B and C, category II <sub>2N3P</sub>		Gas condensing system boiler	
<b>Rated heating output range when operating with natural gas</b>			
80.0/99.0 kW Details to EN 15417			
– T <sub>F</sub> /T <sub>R</sub> = 50/30 °C	kW	20.0 to 80.0	20.0 to 99.0
– T <sub>F</sub> /T <sub>R</sub> = 80/60 °C	kW	18.2 to 74.1	18.2 to 90.9
<b>Rated heating output range when operating with LPG P</b>			
69.0 kW Details to EN 15502-1			
80.0/99.0 kW Details to EN 15417			
– T <sub>F</sub> /T <sub>R</sub> = 50/30 °C	kW	30.0 to 80.0	30.0 to 99.0
– T <sub>F</sub> /T <sub>R</sub> = 80/60 °C	kW	27.3 to 74.1	27.3 to 90.9
<b>Rated heat input</b>			
– For operation with natural gas	kW	18.8 to 75.0	18.8 to 92.9
– For operation with LPG P	kW	28.1 to 75.0	28.1 to 92.9
<b>Type</b>		B2HA	B2HA
<b>Product ID</b>		CE-0085CN0050	
<b>IP rating</b>		IP X4 to EN 60529	
<b>Gas supply pressure</b>			
– Natural gas	mbar	20	20
	kPa	2	2
– LPG	mbar	50	50
	kPa	5	5
<b>Max. perm. gas supply pressure*<sup>5</sup></b>			
– Natural gas	mbar	25.0	25.0
	kPa	2.5	2.5
– LPG	mbar	57.5	57.5
	kPa	5.75	5.75
<b>Sound power level (to EN ISO 15036-1)</b>			
– Partial load	dB(A)	38	38
– Rated heating output	dB(A)	56	59
<b>Power consumption (delivered condition)</b>	W	126	216
<b>Weight</b>	kg	83	83
<b>Heat exchanger capacity</b>	l	12.8	12.8
<b>Max. flow temperature</b>	°C	76	76
<b>Max. flow rate</b>	l/h	5700	5700
Limit for the use of hydraulic separation			
<b>Nominal circulating water volume at T<sub>F</sub>/T<sub>R</sub> = 80/60 °C</b>	l/h	3118	3909
<b>Permiss. operating pressure</b>	bar	4	4
	MPa	0.4	0.4
<b>Dimensions</b>			
– Length	mm	530	530
– Width	mm	480	480
– Height	mm	850	850
<b>Gas connection</b>	R	1	1
<b>Supply values (relative to the max. load)</b>			
– Natural gas E	m <sup>3</sup> /h	7.94	9.83
– Natural gas LL	m <sup>3</sup> /h	9.23	11.43
– LPG	kg/h	5.86	7.26

\*<sup>5</sup> If the gas supply pressure is higher than the maximum permissible value, install a separate gas pressure governor upstream of the system.

## Vitodens 200-W (cont.)

Gas boiler, type B and C, category II <sub>2N3P</sub>		Gas condensing system boiler	
<b>Rated heating output range when operating with natural gas</b>			
<b>80.0/99.0 kW Details to EN 15417</b>			
– T <sub>F</sub> /T <sub>R</sub> = 50/30 °C	kW	20.0 to 80.0	20.0 to 99.0
– T <sub>F</sub> /T <sub>R</sub> = 80/60 °C	kW	18.2 to 74.1	18.2 to 90.9
<b>Flue gas parameters*<sup>6</sup></b>			
Flue gas category to G 635/G 636		G <sub>52</sub> /G <sub>51</sub>	G <sub>52</sub> /G <sub>51</sub>
Temperature (at a return temperature of 30 °C)			
– Rated heating output	°C	46	57
– Partial load	°C	37	37
Temperature (at a return temperature of 60 °C)			
	°C	68	72
<b>Mass flow rate</b>			
Natural gas			
– Rated heating output	kg/h	139	174
– Partial load	kg/h	52	52
LPG			
– Rated heating output	kg/h	132	165
– Partial load	kg/h	49	49
Available draught* <sup>11</sup>	Pa	250	250
	mbar	2.5	2.5
<b>Max. amount of condensate</b>			
– To DWA-A 251	l/h	11.2	14.0
<b>Condensate connection (hose nozzle)</b>	Ø mm	20-24	20-24
<b>Flue gas connection</b>	Ø mm	110	110
<b>Ventilation air connection</b>	Ø mm	150	150
<b>Standard seasonal efficiency [to DIN] at</b>			
– T <sub>F</sub> /T <sub>R</sub> = 40/30 °C	%	Up to 98 (H <sub>s</sub> ) [gross cv]	
<b>Energy efficiency class</b>		–	–
<b>Seasonal space heating energy efficiency*<sup>8</sup></b>		η <sub>s</sub> (%)	94

### Multi boiler systems

For further details regarding multi boiler systems, see page 63.

\*<sup>6</sup> Calculation values for sizing the flue system to EN 13384.

Flue gas temperatures as actual gross values at 20 °C combustion air temperature.

The flue gas temperature at a return temperature of 30 °C is significant for the sizing of the flue system.

The flue gas temperature at a return temperature of 60 °C is used to determine the application range of flue pipes with maximum permissible operating temperatures.

\*<sup>11</sup> CH: Available draught 200 Pa; 2.0 mbar

\*<sup>8</sup> Figure for the appliance only (without control unit). For the final seasonal room heating energy efficiency figure, the system label must be calculated.

# Vitodens 200-W (cont.)

With heating circuit connection set with low loss header

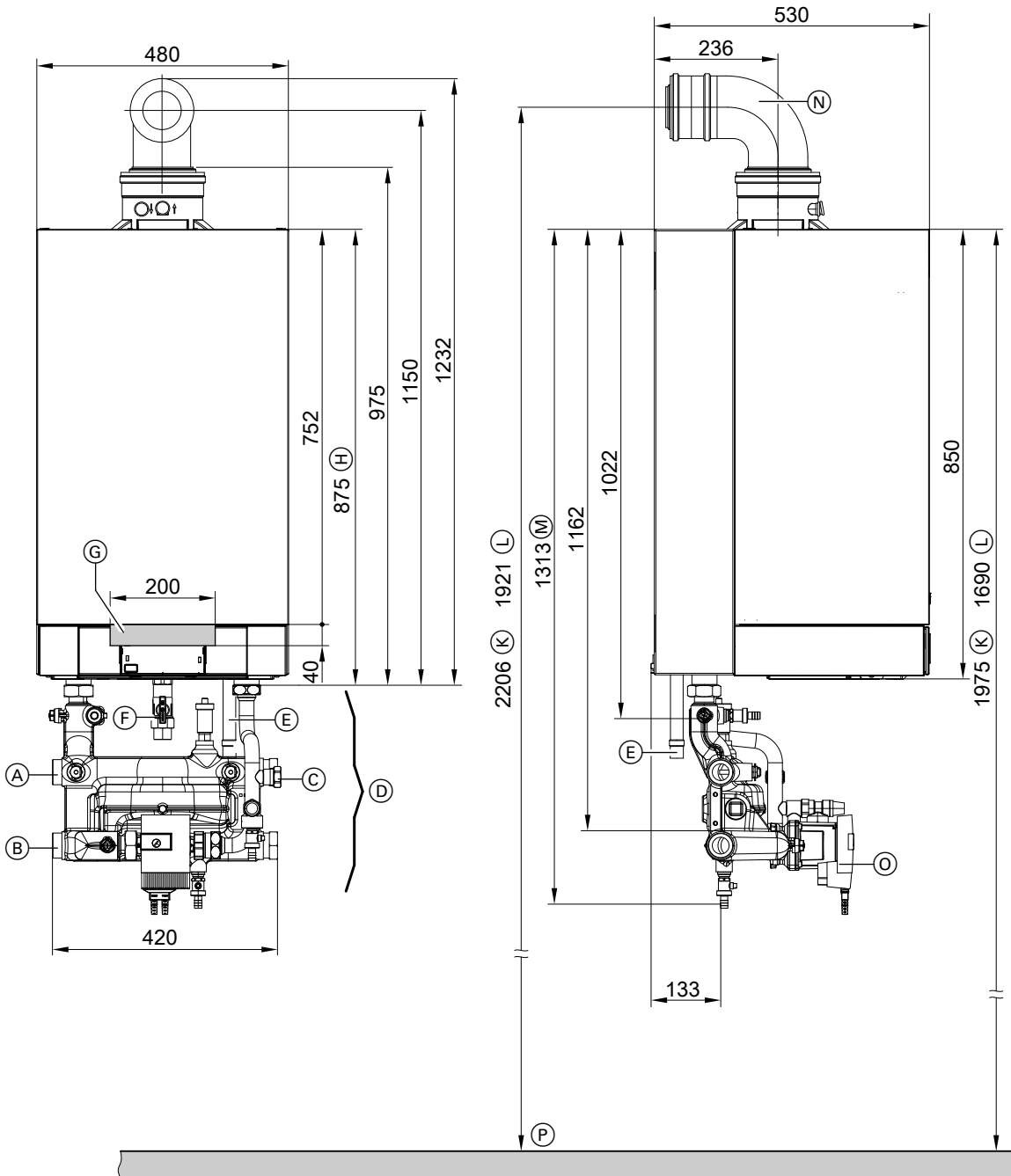

- (A) Heating flow G 1½ (male thread) (connection possible to the left or to the right)
- (B) Heating return G 1½ (male thread) (connection possible to the left or to the right)
- (C) Expansion vessel connection G 1 (male thread)
- (D) Heating circuit connection set with integral low loss header, shown without thermal insulation (standard delivery)
- (E) Condensate drain
- (F) Gas connection Rp 1

- (G) Area for insertion of electrical cables at the back
- (H) Without connection sets
- (K) Recommended dimension for single boiler system
- (L) Recommended dimension for multi boiler system
- (M) With connection sets
- (N) Balanced flue bend (accessories)
- (O) Safety valve  
(PL/IT: Without safety valve)
- (P) Top edge of finished floor

**Note**

- A heating circuit connection set **must** be ordered separately.
- Lay all required power cables on site and route them into the boiler in the specified area.

**Operating principle of the low loss header**

The low loss header integrated into the heating circuit connection set is sized for the max. flow rate which may occur in the overall system. When balancing the low loss header, adjust the flow rate on the boiler side (V primary (A)) to approx. 10 to 30 % below the flow rate on the system side (V secondary (B)) (return temperature reduction).

5822432

## Vitodens 200-W (cont.)

The low loss header separates the heat generator circuit (boiler circuit) from the following heating circuits.

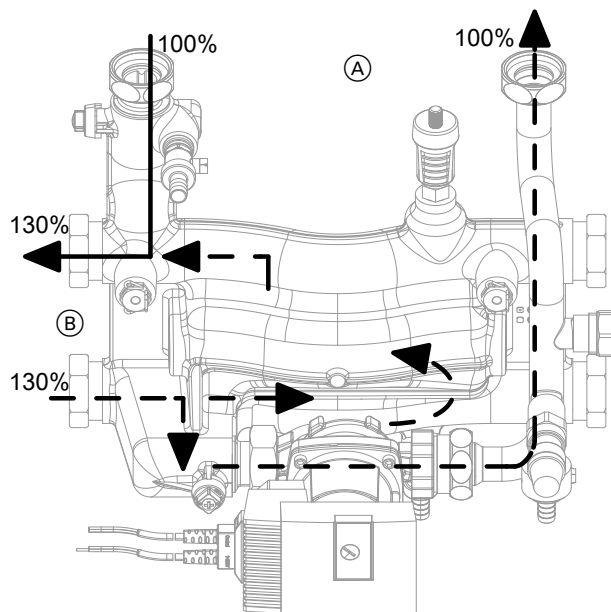

- (A) V primary
- (B) V secondary

### High efficiency circulation pump in the heating circuit connection set (accessories)

The HE circulation pump consumes significantly less power than conventional pumps.

By matching the pump rate of the circulation pump to the individual system conditions, the power consumption of the heating system is reduced.

#### Circulation pump VI Para MAXO 25-130/11 (0 to 10 V)

<b>Rated voltage</b>	V~	230
<b>Power consumption</b>		
– max.	W	140
– min.	W	8

### Adjust the functioning of the primary side circulation pump during commissioning

Hydraulic connection/connection requirements	Control unit setting Coding address/group	Circulation pump setting Recommendation
Single boiler system Connection of heating circuits with connection set with integral low loss header <b>Circulation pump VI Para MAXO 25-130/11</b>	30:0/boiler/2	 $\Delta p-c$ – 80 kW at $\Delta t = 16\text{ K} \rightarrow \dot{V} \approx 4.03\text{ m}^3/\text{h}$ – 99 kW at $\Delta t = 20\text{ K} \rightarrow \dot{V} \approx 4.02\text{ m}^3/\text{h}$

### Pressure drop on the heating water side

For sizing a cylinder loading pump (on site)

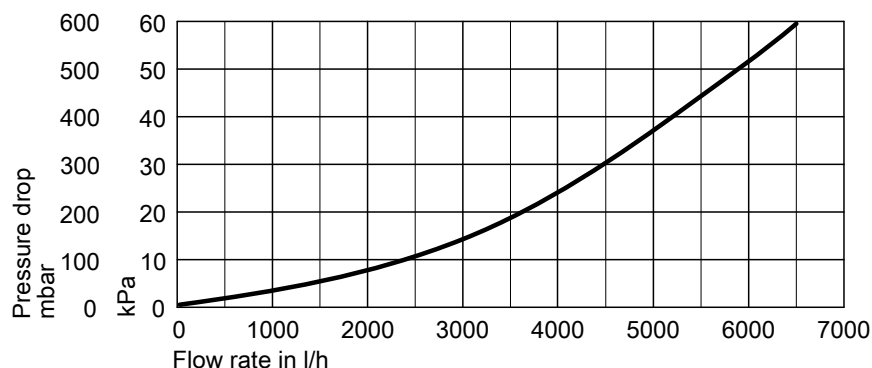

#### Note

If operating the heating circuit pump and circulation pump for cylinder heating in parallel (no DHW priority control), we recommend installing the DHW cylinder in the secondary side of the heating system.



## Vitodens 200-W (cont.)

With heating circuit connection set for combination with system separation or heating water buffer cylinder

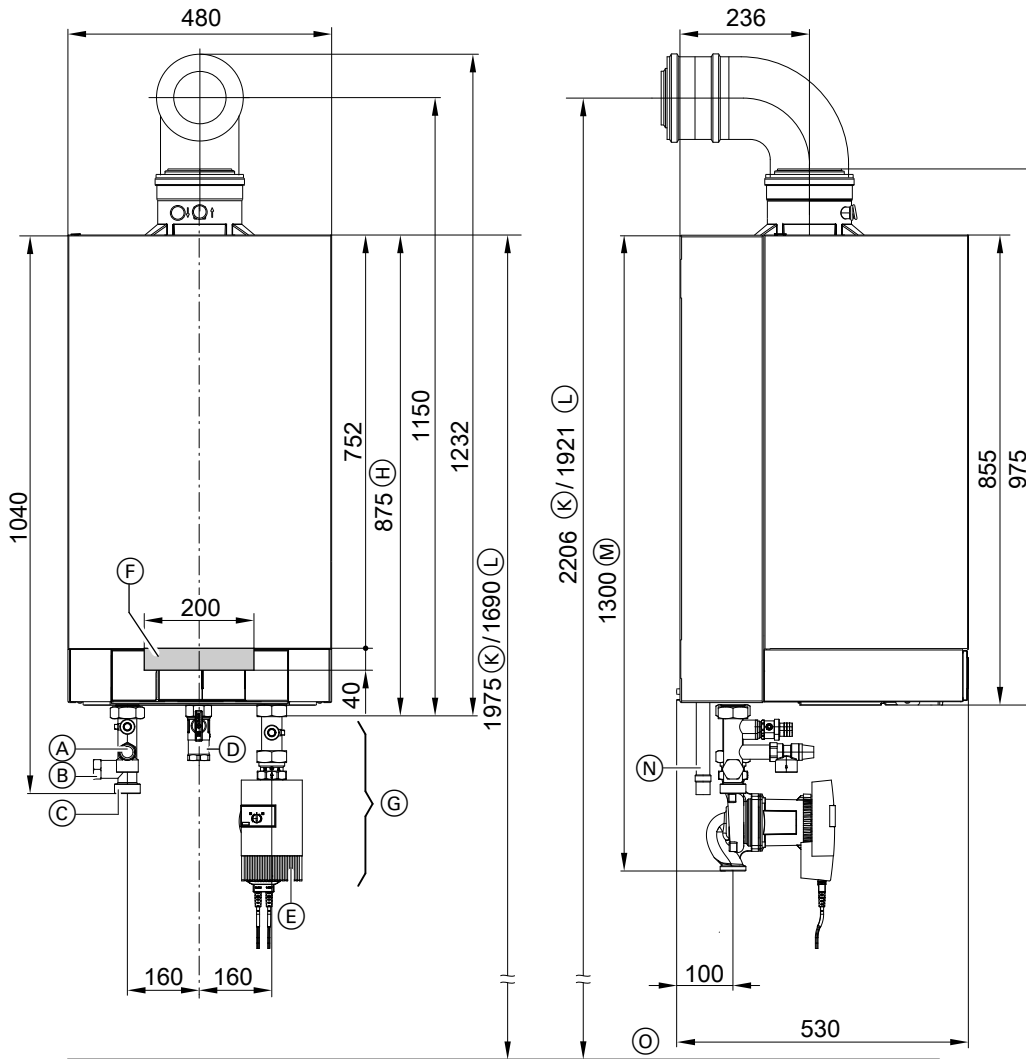

- (A) Safety valve
- (B) Connection for expansion vessel G 1 (male thread)
- (C) Boiler flow G 1 ½ (male thread)
- (D) Gas connection Rp 1
- (E) Boiler return G 1 ½ (male thread)
- (F) Area for insertion of electrical cables at the back

- (G) Connection sets (accessories)
- (H) Without connection set (accessories)
- (K) Recommended dimension (single boiler system)
- (L) Recommended dimension (multi boiler system)
- (M) With connection set (accessories)
- (N) Condensate drain
- (O) Top edge of finished floor

### Note

- A heating circuit connection set **must** be ordered separately.
- Lay all required power cables on site and route them into the boiler in the specified area.

### Variable speed high efficiency circulation pump in the heating circuit connection set (accessories)

The HE circulation pump consumes significantly less power than conventional pumps.

By matching the pump rate of the circulation pump to the individual system conditions, the power consumption of the heating system is reduced.

### Circulation pump VI PARA 25/1-12, (0 to 10 V)

Rated voltage	V~	230
Power consumption		
– max.	W	310
– min.	W	16



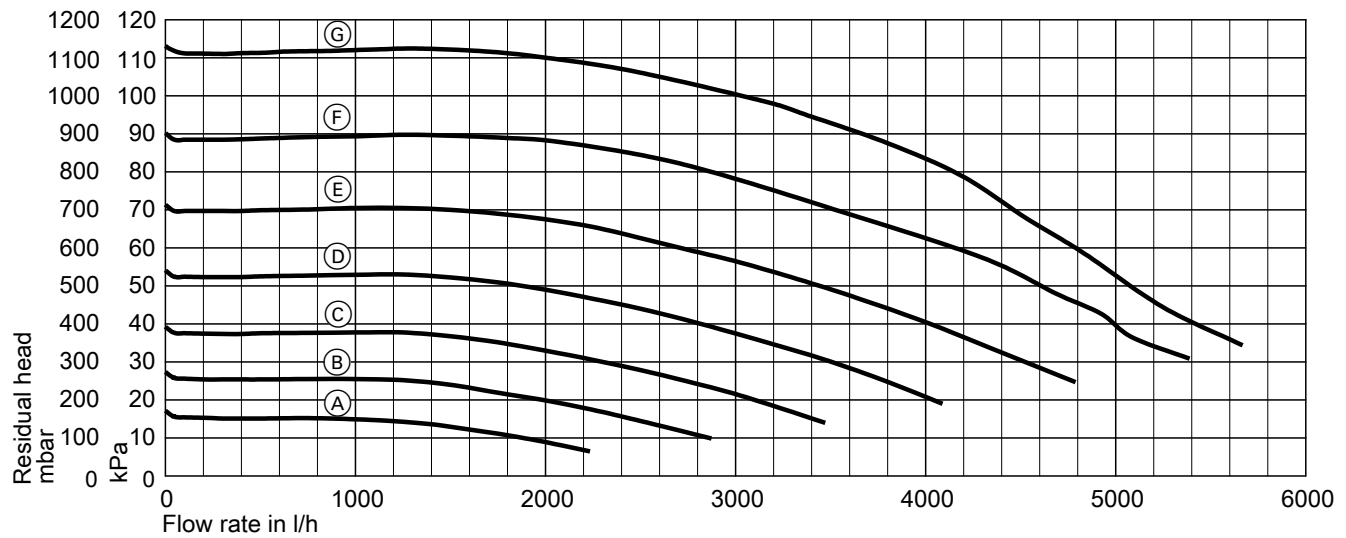

# Vitodens 200-W (cont.)

## Residual heads of circulation pump

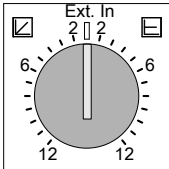
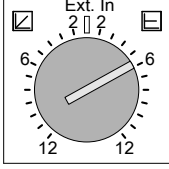

Curve	Pump rate of circulation pump
(A)	40 %
(B)	50 %
(C)	60 %
(D)	70 %
(E)	80 %
(F)	90 %
(G)	100 %

### Adjusting the circulation pump function during commissioning

Hydraulic connection/connection requirements	Control unit setting Coding address/group	Circulation pump setting (recommendation)
Single boiler system with: – Heating circuit without mixer – Connection without low loss header and without heating water buffer cylinder – <b>Circulation pump VI PARA 25/1-12</b>	– Max. pump speed: E6: ... /heating circuit – Min. pump speed: E7: ... /heating circuit	Ext. in 
Single boiler system with connection of the heating circuits to the heating water buffer cylinder <b>Circulation pump VI PARA 25/1-12</b>	30:0/boiler/2	 Recommended for $\Delta t = 15\text{ K}$ – 80 kW:  = $6 \pm 4.59\text{ m}^3/\text{h}$ – 99 kW:  = $10 \pm 5.70\text{ m}^3/\text{h}$
Multi boiler system <b>Circulation pump VI Para MAXO 25-130/11</b>	30:0/boiler/2	 $\Delta p\text{-c}$ – 80 kW at $\Delta t = 20\text{ K} \rightarrow \text{dial icon} \approx 3.43\text{ m}^3/\text{h}$ – 99 kW at $\Delta t = 20\text{ K} \rightarrow \text{dial icon} \approx 4.25\text{ m}^3/\text{h}$
Multi stage circulation pump (on site)	30:0/boiler/2	

## Vitodens 200-W (cont.)

### Note

If the residual head of the circulation pump available as an accessory is insufficient to overcome the following system pressure drop values, install an additional, external circulation pump on site. In this case either the heating circuit connection with integral low loss header, a system separation or a heating water buffer cylinder must be used.

### Pressure drop on the heating water side

For sizing a circulation pump (accessories or on site)

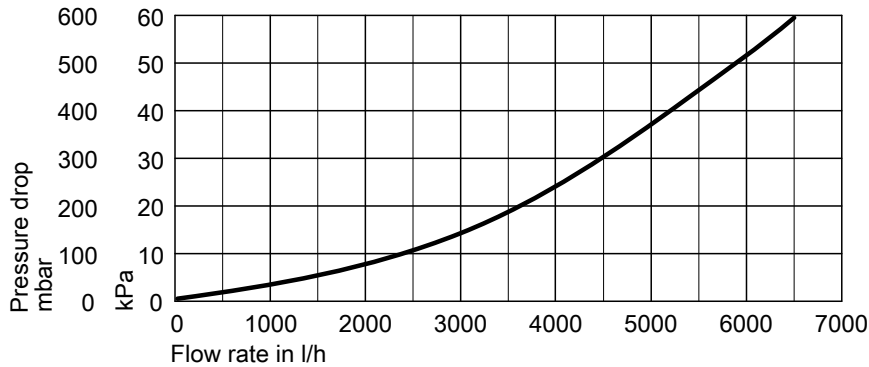

### Note

If operating the heating circuit pump and circulation pump for cylinder heating in parallel mode (no DHW priority control), we recommend installing the DHW cylinder in the secondary side of the heating system (downstream of the system separation or the heating water buffer cylinder).

**1.4 Specification for the Vitodens 200-W, 120 and 150 kW**

Gas boiler, type B and C, category II <sub>2N3P</sub>		Gas condensing system boiler	
<b>Rated heating output range when operating with natural gas</b>			
Details to EN 15417			
– T <sub>F</sub> /T <sub>R</sub> = 50/30 °C	kW	32.0 to 120.0	32.0 to 150.0
– T <sub>F</sub> /T <sub>R</sub> = 80/60 °C	kW	29.1 to 110.9	29.0 to 136.0
<b>Rated heating output range when operating with LPG P</b>			
Details to EN 15417			
– T <sub>F</sub> /T <sub>R</sub> = 50/30 °C	kW	32.0 to 120.0	32.0 to 150.0
– T <sub>F</sub> /T <sub>R</sub> = 80/60 °C	kW	29.1 to 110.9	29.0 to 136.0
<b>Rated heat input</b>			
– For operation with natural gas	kW	30.0 to 113.3	30.0 to 142.0
– For operation with LPG P	kW	30.0 to 113.3	30.0 to 142.0
<b>Type</b>		B2HA	B2HA
<b>Product ID</b>		CE-0085CN0050	
<b>IP rating</b>		IP X4 to EN 60529	
<b>Gas supply pressure</b>			
– Natural gas	mbar	20	20
	kPa	2	2
– LPG	mbar	50	50
	kPa	5	5
<b>Max. permiss. gas supply pressure<sup>*9</sup></b>			
– Natural gas	mbar	25.0	25.0
	kPa	2.5	2.5
– LPG	mbar	57.5	57.5
	kPa	5.75	5.75
<b>Sound power level (to EN ISO 15036-1)</b>			
– Partial load	dB(A)	40	40
– Rated heating output	dB(A)	54	60
<b>Power consumption (delivered condition)</b>	W	146	222
<b>Weight</b>	kg	130	130
<b>Heat exchanger capacity</b>	l	15.0	15.0
<b>Max. flow temperature</b>	°C	82	82
<b>Max. flow rate</b>	l/h	7165	8600
Limit for the use of hydraulic separation			
<b>Nominal circulating water volume at T<sub>F</sub>/T<sub>R</sub> = 80/60 °C</b>	l/h	4900	5850
<b>Permiss. operating pressure</b>	bar	6	6
	MPa	0.6	0.6
<b>Dimensions</b>			
– Length	mm	690	690
– Width	mm	600	600
– Height	mm	900	900
<b>Gas connection</b>	R	1	1
<b>Supply values (relative to the max. load)</b>			
– Natural gas E	m <sup>3</sup> /h	11.99	15.03
– Natural gas LL	m <sup>3</sup> /h	13.94	17.47
– LPG	kg/h	8.86	11.10

\*9 If the gas supply pressure is higher than the maximum permissible value, install a separate gas pressure governor upstream of the system.

## Vitodens 200-W (cont.)

Gas boiler, type B and C, category II <sub>2N3P</sub>		Gas condensing system boiler	
<b>Rated heating output range when operating with natural gas</b>			
<b>Details to EN 15417</b>			
– T <sub>F</sub> /T <sub>R</sub> = 50/30 °C	kW	32.0 to 120.0	32.0 to 150.0
– T <sub>F</sub> /T <sub>R</sub> = 80/60 °C	kW	29.1 to 110.9	29.0 to 136.0
<b>Flue gas parameters<sup>*10</sup></b>			
Flue gas category to G 635/G 636		G <sub>52</sub> /G <sub>51</sub>	G <sub>52</sub> /G <sub>51</sub>
Temperature (at a return temperature of 30 °C)			
– Rated heating output	°C	51	60
– Partial load	°C	39	39
Temperature (at a return temperature of 60 °C)			
	°C	70	74
<b>Mass flow rate</b>			
Natural gas			
– Rated heating output	kg/h	210	253
– Partial load	kg/h	53	53
LPG			
– Rated heating output	kg/h	231	278
– Partial load	kg/h	59	59
Available draught <sup>*11</sup>	Pa	250	250
	mbar	2.5	2.5
<b>Max. amount of condensate</b>			
– To DWA-A 251	l/h	17.5	21.0
<b>Condensate connection (hose nozzle)</b>	Ø mm	20-24	20-24
<b>Flue gas connection</b>	Ø mm	110	110
<b>Ventilation air connection</b>	Ø mm	150	150
<b>Standard seasonal efficiency [to DIN] at</b>			
– T <sub>F</sub> /T <sub>R</sub> = 40/30 °C	%	Up to 98 (H <sub>s</sub> ) [gross cv]	
<b>Energy efficiency class</b>			
		–	–
<b>Seasonal space heating energy efficiency<sup>*12</sup></b>	η <sub>s</sub> (%)	92	92

### Multi boiler systems

For further details regarding multi boiler systems, see page 63.

<sup>\*10</sup> Calculation values for sizing the flue system to EN 13384.

Flue gas temperatures as actual gross values at 20 °C combustion air temperature.

The flue gas temperature at a return temperature of 30 °C is significant for the sizing of the flue system.

The flue gas temperature at a return temperature of 60 °C is used to determine the application range of flue pipes with maximum permissible operating temperatures.

<sup>\*11</sup> CH: Available draught 200 Pa; 2.0 mbar

<sup>\*12</sup> Figure for the appliance only (without control unit). For the final seasonal room heating energy efficiency figure, the system label must be calculated.

## Vitodens 200-W (cont.)

With heating circuit connection set with low loss header

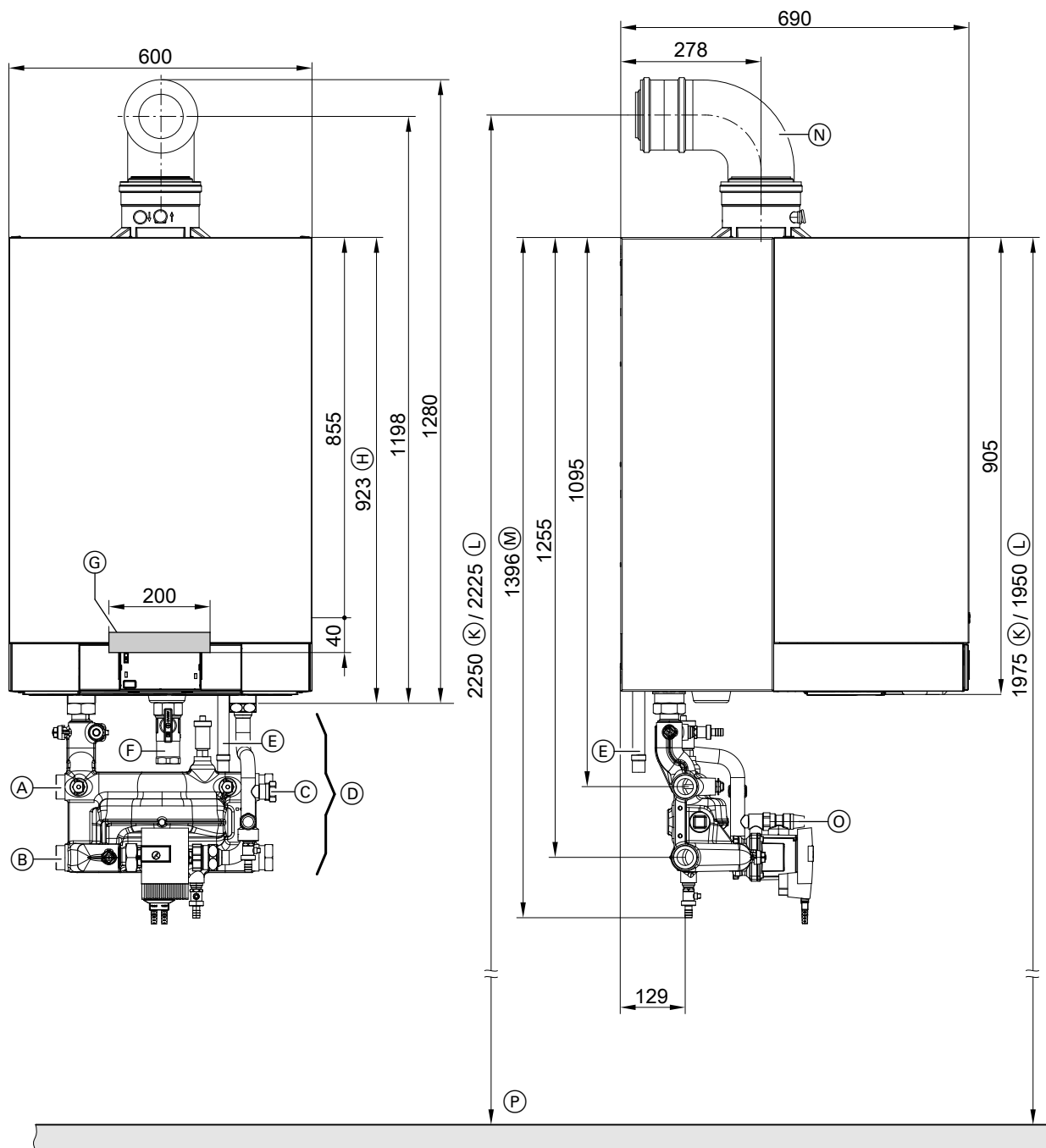

- (A) Heating flow G 2 (male thread) (connection possible to the left or to the right)
- (B) Heating return G 2 (male thread) (connection possible to the left or to the right)
- (C) Expansion vessel connection G 1 (male thread)
- (D) Heating circuit connection set with integral low loss header, shown without thermal insulation (standard delivery)
- (E) Condensate drain
- (F) Gas connection Rp 1
- (G) Area for insertion of electrical cables at the back

- (H) Without connection sets
- (K) Recommended dimension for single boiler system without mounting frame
- (L) Recommended dimension for multi boiler system or single boiler system with mounting frame
- (M) With connection sets
- (N) Balanced flue bend (accessories)
- (O) Safety valve (PL/IT: Without safety valve)
- (P) Top edge of finished floor

### Note

- A heating circuit connection set **must** be ordered separately.
- Lay all required power cables on site and route them into the boiler in the specified area.

### Operating principle of the low loss header

The low loss header integrated into the heating circuit connection set is sized for the max. flow rate which may occur in the overall system.

## Vitodens 200-W (cont.)

When balancing the low loss header, adjust the flow rate on the boiler side (V primary (A)) to approx. 10 to 30 % below the flow rate on the system side (V secondary (B)) (return temperature reduction). The low loss header separates the heat generator circuit (boiler circuit) from the following heating circuits.

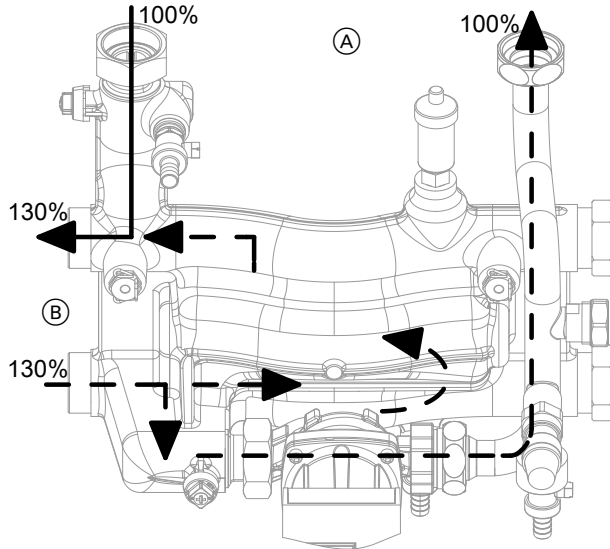

- (A) V primary
- (B) V secondary

### High efficiency circulation pump in the heating circuit connection set (accessories)

The HE circulation pump consumes significantly less power than conventional pumps.





By matching the pump rate of the circulation pump to the individual system conditions, the power consumption of the heating system is reduced.

#### Circulation pump VI PARA 30/1-12, (0 to 10 V)

<b>Rated voltage</b>	V~	230
<b>Power consumption</b>		
– max.	W	310
– min.	W	16

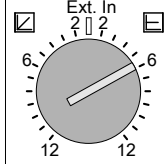
Variable speed ( $\Delta p$  constant or  $\Delta p$  variable), fully wired.

### Adjust the functioning of the primary side circulation pump during commissioning

Hydraulic connection/connection requirements	Control unit setting Coding address/group	Circulation pump setting (recommendation)
Single boiler system Connection of heating circuits with connection set with integral low loss header <b>Circulation pump VI PARA 30/1-12</b>	30:0/boiler/2	 <p>Recommended for <math>\Delta t = 15</math> K</p> <ul style="list-style-type: none"> <li>– 120 kW:  = <math>4 \pm 6.87</math> m<sup>3</sup>/h</li> <li>– 150 kW:  = <math>6 \pm 8.40</math> m<sup>3</sup>/h</li> </ul> <p>Recommended for <math>\Delta t = 20</math> K</p> <ul style="list-style-type: none"> <li>– 120 kW:  = <math>2 \pm 5.16</math> m<sup>3</sup>/h</li> <li>– 150 kW:  = <math>3 \pm 6.44</math> m<sup>3</sup>/h</li> </ul>

## Vitodens 200-W (cont.)

**Pressure drop on the heating water side**  
For sizing a cylinder loading pump (on site).

For DHW cylinder connection set for connecting the DHW cylinder upstream of the low loss header, see accessories.

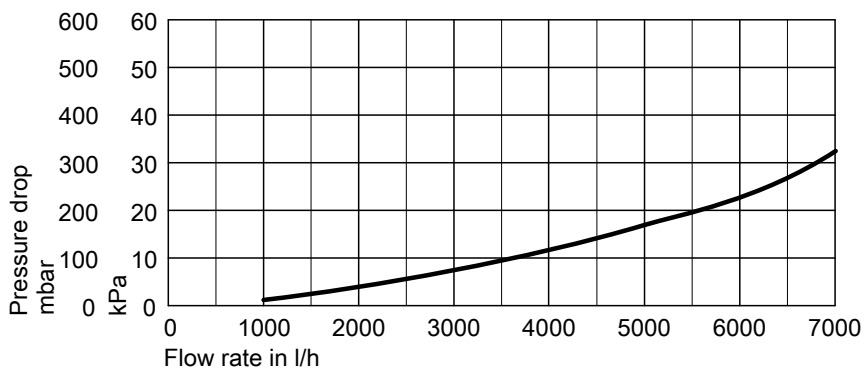

**Note**

*If operating the heating circuit pump and circulation pump for cylinder heating in parallel (no DHW priority control), we recommend installing the DHW cylinder in the secondary side of the heating system.*



## Vitodens 200-W (cont.)

With heating circuit connection set for combination with system separation or heating water buffer cylinder

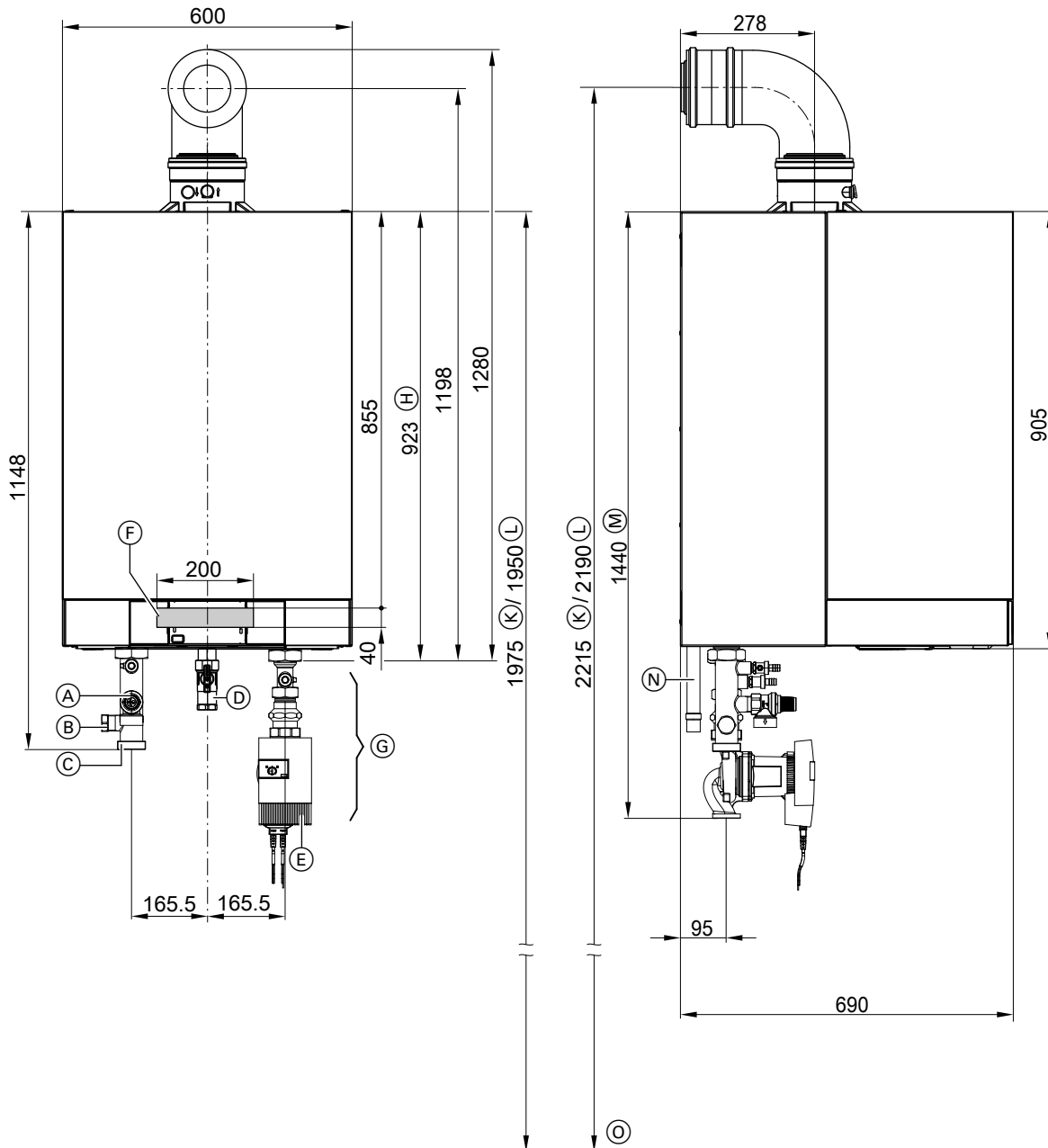

- |   |   |
|---|---|
| (A) Safety valve  | (H) Without connection set (accessories)  |
| (B) Connection for expansion vessel G 1 (male thread)   | (K) Recommended dimension (single boiler system without mounting frame)                     |
| (C) Boiler flow G 2 (male thread)                       | (L) Recommended dimension (multi boiler system or single boiler system with mounting frame) |
| (D) Gas connection Rp 1                                 | (M) With heating circuit connection set (accessories)                                       |
| (E) Boiler return G 2 (male thread)                     | (N) Condensate drain  |
| (F) Area for insertion of electrical cables at the back | (O) Top edge of finished floor  |
| (G) Connection set (accessories)                        |   |

### Note

- A heating circuit connection set **must** be ordered separately.
- Lay all required power cables on site and route them into the boiler in the specified area.

### Variable speed high efficiency circulation pump in the heating circuit connection set (accessories)

The HE circulation pump consumes significantly less power than conventional pumps.

By matching the pump rate of the circulation pump to the individual system conditions, the power consumption of the heating system is reduced.

## Vitodens 200-W (cont.)

### Circulation pump VI PARA 30/1-12, (0 to 10 V)

Rated voltage	V~	230
Power consumption		
– max.	W	310
– min.	W	16

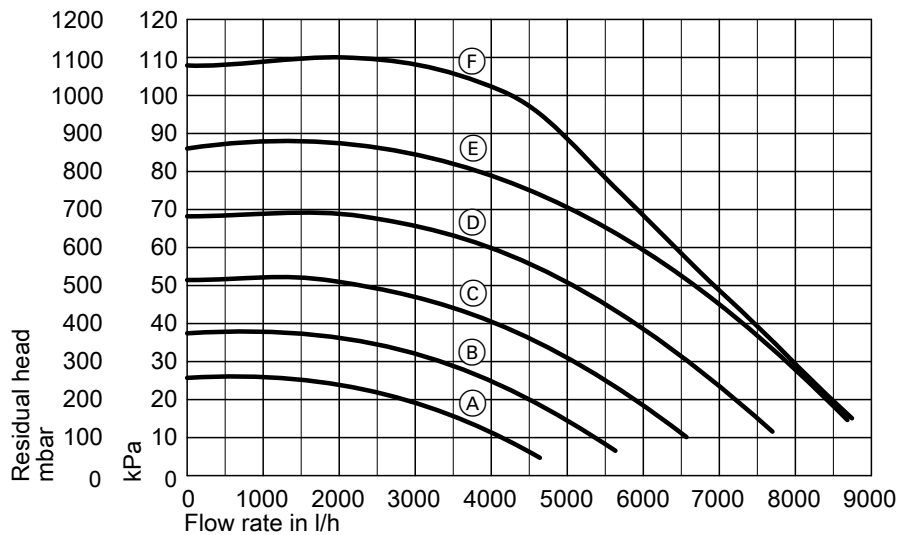

Variable speed ( $\Delta p$  constant or  $\Delta p$  variable), fully wired.

### Residual heads of circulation pump



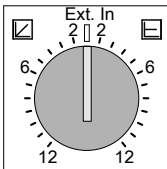
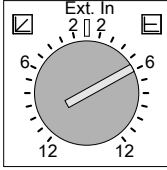

Curve	Pump rate of circulation pump
(A)	50 %
(B)	60 %
(C)	70 %
(D)	80 %
(E)	90 %
(F)	100 %

### Adjusting the circulation pump function during commissioning

Hydraulic connection/connection requirements	Control unit setting Coding address/group	Circulation pump setting (recommendation)
Single boiler system with: – Heating circuit without mixer – Connection without low loss header and without heating water buffer cylinder  <b>Circulation pump VI PARA 30/1-12</b>	– Max. pump speed: E6: ... /heating circuit – Min. pump speed: E7: ... /heating circuit For further details, see following diagram and chapter "Heating circuit ..." under code 2.	Ext. in 
Single boiler system with connection of the heating circuits to the heating water buffer cylinder <b>Circulation pump VI PARA 30/1-12</b>	30:0/boiler/2	  Recommended for $\Delta t = 15 \text{ K}$ – 120 kW:  = $3 \pm 6.87 \text{ m}^3/\text{h}$ – 150 kW:  = $6 \pm 8.60 \text{ m}^3/\text{h}$

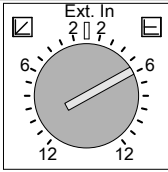
## Vitodens 200-W (cont.)

Hydraulic connection/connection requirements	Control unit setting Coding address/group	Circulation pump setting (recommendation)
Multi boiler system Circulation pump VI PARA 30/1-12	30:0/boiler/2	 <p>Recommended for <math>\Delta t = 15 \text{ K}</math>            – 120 kW:  = <math>3 \pm 6.87 \text{ m}^3/\text{h}</math>            – 150 kW:  = <math>6 \pm 8.60 \text{ m}^3/\text{h}</math></p>
Multi stage circulation pump (on site)	30:0/boiler/2	

### Note

If the residual head of the circulation pump available as an accessory is insufficient to overcome the following system pressure drop values, install an additional, external circulation pump on site. In this case either the heating circuit connection with integral low loss header, a system separation or a heating water buffer cylinder must be used.

### Pressure drop on the heating water side

For sizing a circulation pump (accessories or on site)

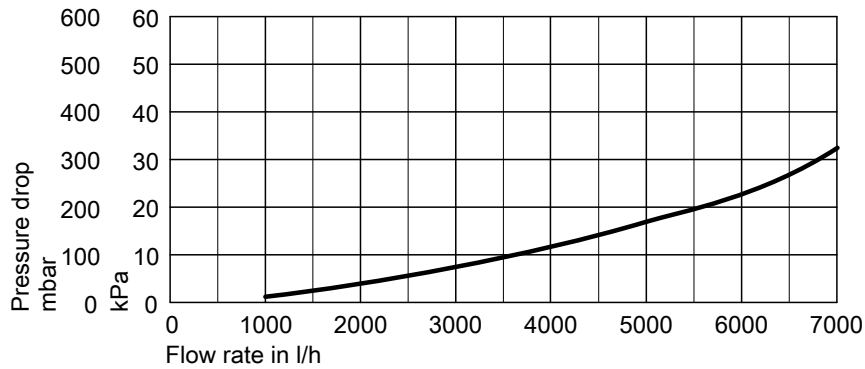

### Note

If operating the heating circuit pump and circulation pump for cylinder heating in parallel (no DHW priority control), we recommend installing the DHW cylinder in the secondary side of the heating system (downstream of the low loss header).

## Installation accessories

### 2.1 Installation accessories for Vitodens 200-W, 49 and 60 kW

#### Heating circuit connection set with variable speed high efficiency circulation pump and low loss header

Part no. ZK03663

Connections G 1½ (male thread)

Components:

- Boiler drain & fill valve
- Safety valve 4 bar (0.4 MPa)
- Variable speed high efficiency circulation pump
- Straight-through gas valve with integral, thermally activated safety shut-off valve Rp ¾
- Low loss header with immersion temperature sensor
- Quick-action air vent valve
- Connection G 1 (male thread) for diaphragm expansion vessel
- Thermal insulation

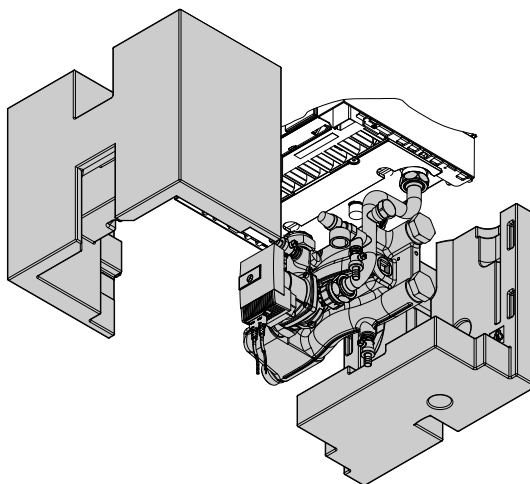

#### Connection set for heating circuit without circulation pump for combination with external system separation or heating water buffer cylinder

Part no. 7245738

Connections G 1½ male thread

Components:

- Tee with ball valve
- Boiler drain & fill valve
- Safety valve 4 bar (0.4 MPa)
- Gas shut-off valve with integral thermally activated safety shut-off valve Rp ¾
- Connection G 1 male thread for diaphragm expansion vessel

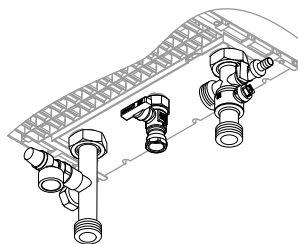

#### DHW cylinder connection set

Part no. ZK03669

For combination with the connection set for heating circuit with high efficiency circulation pump and low loss header.

Components:

- 2 tees G 1½ (male thread)

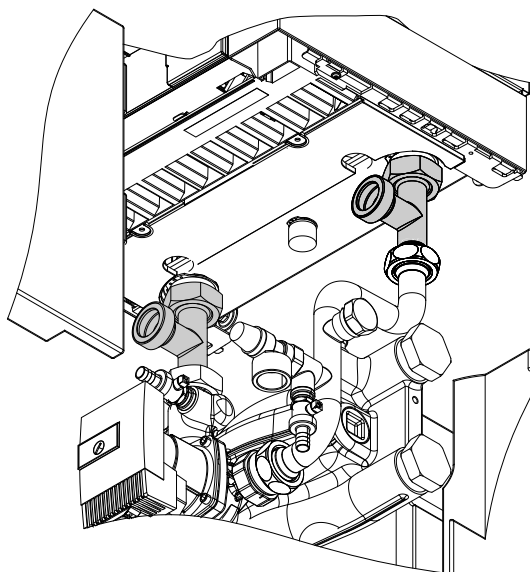
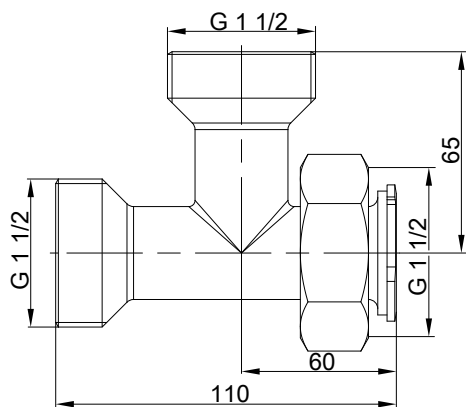

## Installation accessories (cont.)

### Connection set for combination of Vitodens 200-W with CHP unit

**Part no. 7237422**

For combination with the connection set for heating circuit with high efficiency circulation pump and low loss header. For connection of the CHP unit return downstream of the low loss header.

Components:

- Tee G 1½

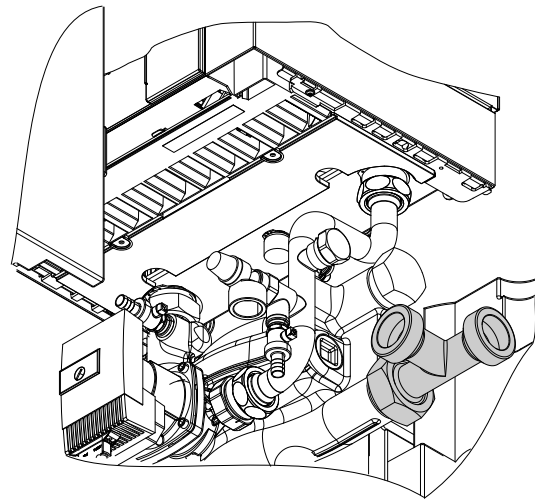
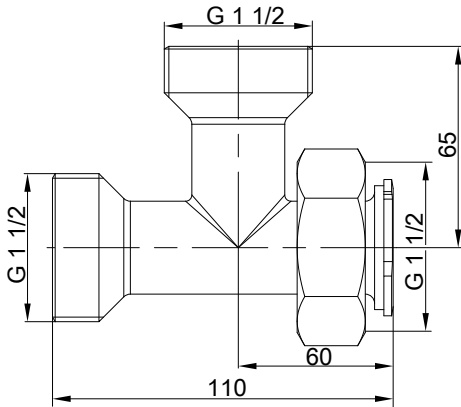

### Connection accessories for installation to the left/right

**Part no. ZK03673**

For combination with the connection set for heating circuit with high efficiency circulation pump and low loss header.

Components:

- 2 pipe sections R 1¼ (male thread)

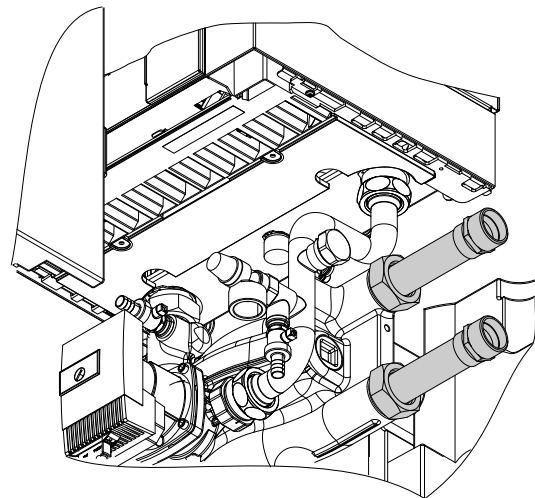
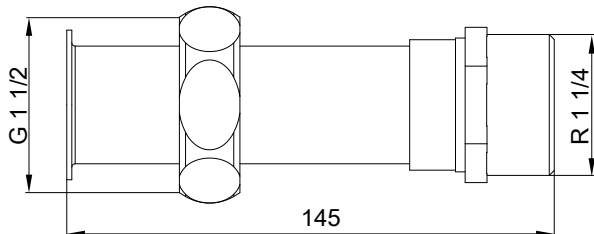

### Connection accessories for installation to the top/bottom

**Part no. ZK03675**

For combination with the connection set for heating circuit with high efficiency circulation pump and low loss header.

Components:

- 2 pipe bends R 1¼ (male thread)

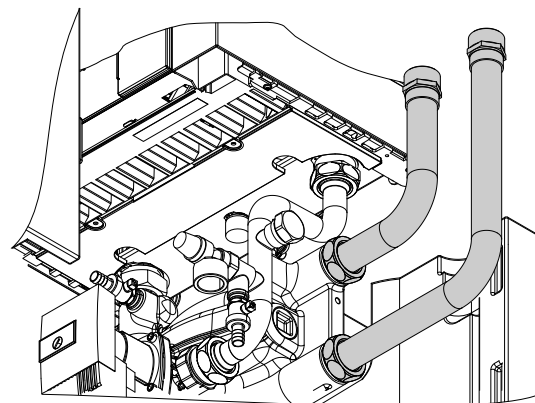

## Installation accessories (cont.)

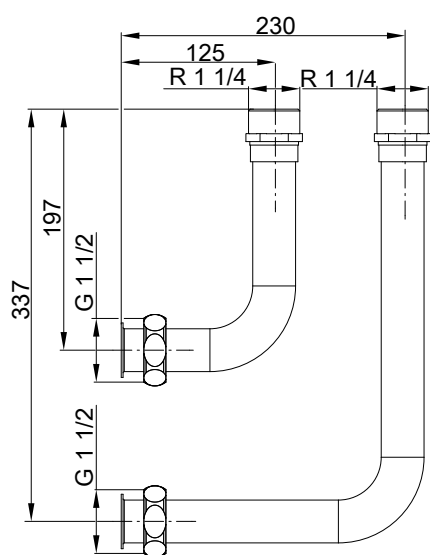

### Dual sensor well for combination of Vitodens 200-W with heat pump

**Part no. ZK03672**

For installation in the heating circuit connection set, for positioning a second flow temperature sensor.

For combination with the connection set for heating circuit with high efficiency circulation pump and low loss header.

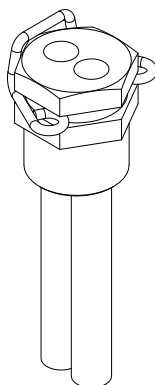

### Wall mounting bracket

**Part no. ZK03677**

For combination with the connection set for heating circuit with variable speed high efficiency circulation pump and low loss header.

Only required for installations without mounting frame.

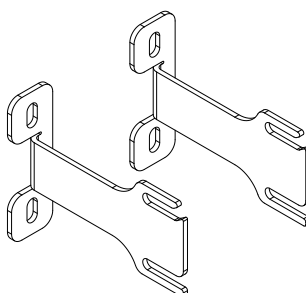

### Mounting frame

**Part no. ZK03678**

For combination with the connection set for heating circuit with high efficiency circulation pump and low loss header.

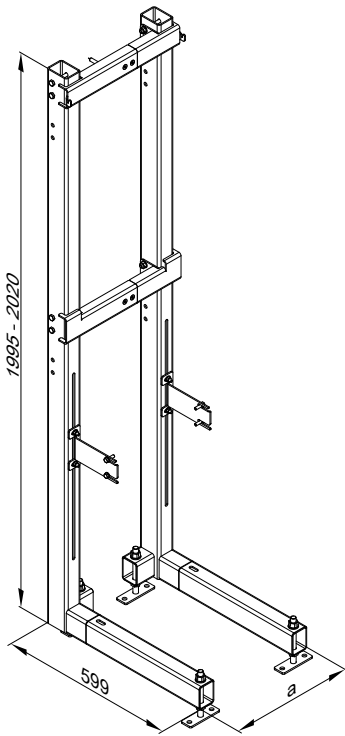

a Adjustable to appliance width

**Immersion temperature sensor (for low loss header)**

**Part no. 7179488**  
To capture the low loss header temperature.

Additional sensor for dual sensor well. **For dual mode or multi mode heating systems.**

**CO limiter**

Monitoring device for safety shutdown of the boiler in the event of escaping carbon monoxide.  
Wall mounting in the ceiling area near the boiler.

CO limiter for boiler	Part no.
Vitoladens 300-C	<b>Z015500</b>
Vitorondens 200-T up to 55 kW, Vitoladens 300-T	<b>Z021823</b>
Vitodens 200	<b>Z024247</b>
Vitocrossal 200, type C1B	
Vitocrossal 300	
Vitocrossal 300, type C13	
Vitorondens 200-T, type J2RA	

Components:

- Casing with
  - Integral CO sensor
  - Mode, fault and alarm indicators
  - Acoustic alarm system
- Communication cable for interface (2.5 m)
- Interface inside the casing with power cable (1.2 m) and connecting lead for burner shutdown relay (1.2 m)
- Fixing materials
- For Vitoladens 300-T and Vitorondens 200-T, including connecting cable for connection to the corresponding boiler

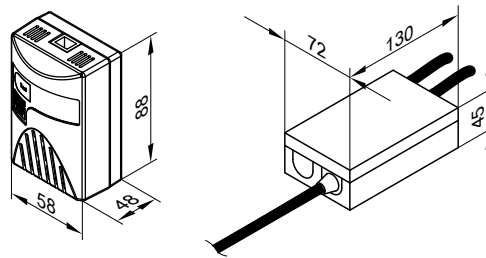

**Specification**

Rated voltage	230 V~
Rated frequency	50 Hz
Power consumption	2 W
Rated breaking capacity of the relay output	8 A 230 V~
Alarm threshold	55 ppm CO to EN 50291-1
Protection class	II
IP rating	IP 20 to EN 60529; ensure through design/installation.
Permissible ambient temperature	0 °C to 40 °C

## 2.2 Installation accessories for Vitodens 200-W, 80 and 99 kW

### Heating circuit connection set with variable speed high efficiency circulation pump and low loss header

Part no. ZK03831

Connections G 1½ (male thread)

Components:

- Boiler drain & fill valve
- Safety valve 4 bar (0.4 MPa)
- Variable speed high efficiency circulation pump
- Straight-through gas valve with integral, thermally activated safety shut-off valve Rp 1
- Low loss header with immersion temperature sensor
- Quick-action air vent valve
- Connection G 1 (male thread) for diaphragm expansion vessel
- Thermal insulation

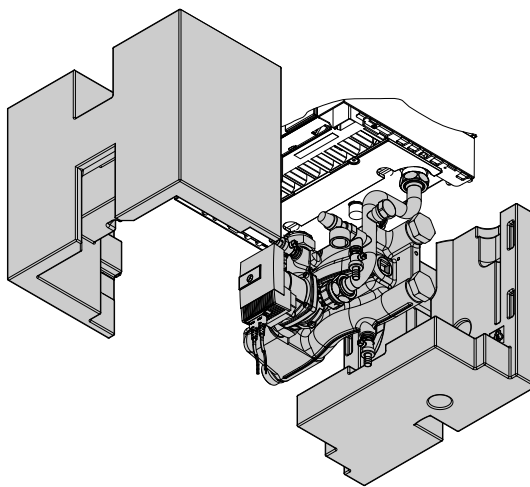

### Connection set for heating circuit with high efficiency circulation pump for combination with external system separation or heating water buffer cylinder

Part no. 7501320

Connections G 1½ (male thread)

Components:

- Variable speed high efficiency circulation pump
- Tees
- Non-return valve
- Boiler drain & fill valve
- Gas shut-off valve with integral thermally activated safety shut-off valve Rp 1

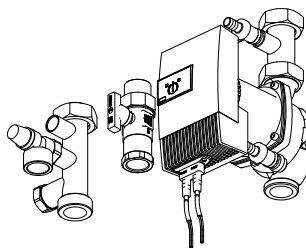

### DHW cylinder connection set

Part no. ZK03669

For combination with the connection set for heating circuit with high efficiency circulation pump and low loss header.

Components:

- 2 tees G 1½ (male thread)

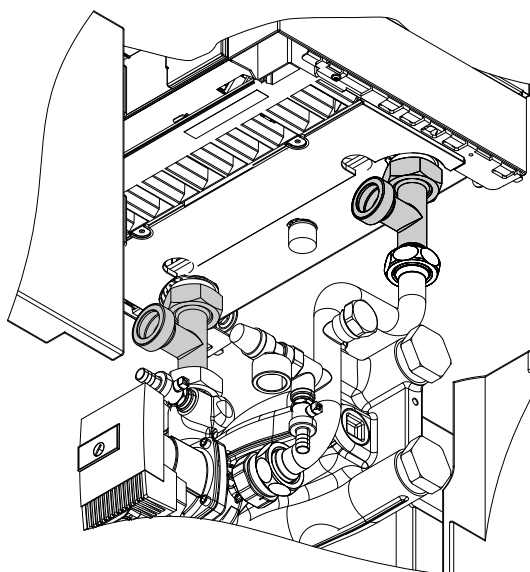
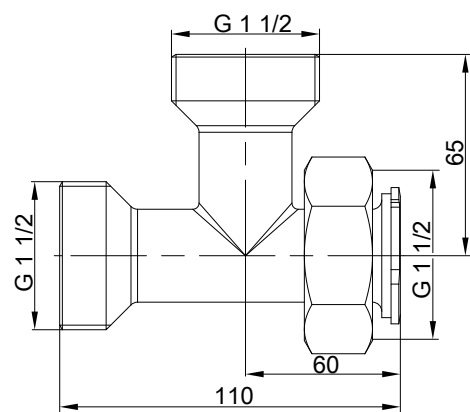



## Installation accessories (cont.)

### Connection set for combination of Vitodens 200-W with CHP unit

**Part no. 7237422**

For combination with the connection set for heating circuit with high efficiency circulation pump and low loss header. For connection of the CHP unit return downstream of the low loss header.

Components:

- Tee G 1½

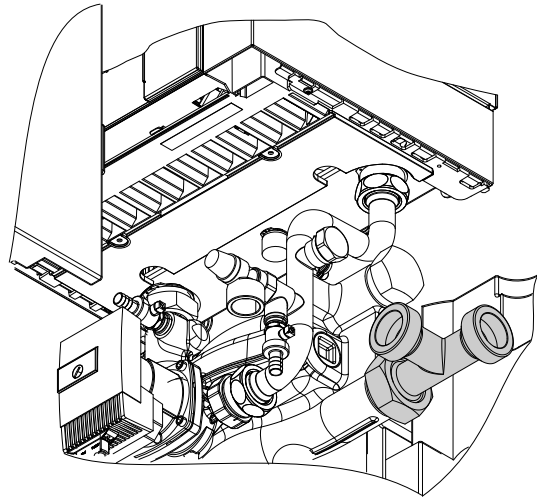
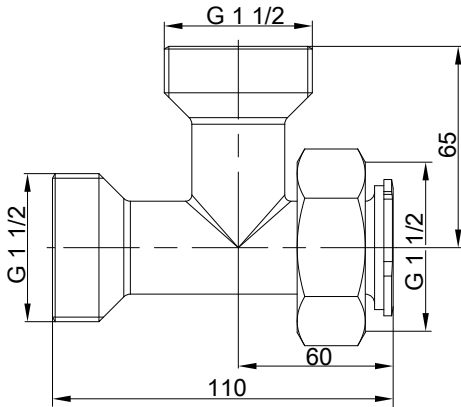

### Connection accessories for installation to the left/right

**Part no. ZK03673**

For combination with the connection set for heating circuit with high efficiency circulation pump and low loss header.

Components:

- 2 pipe sections R 1¼ (male thread)

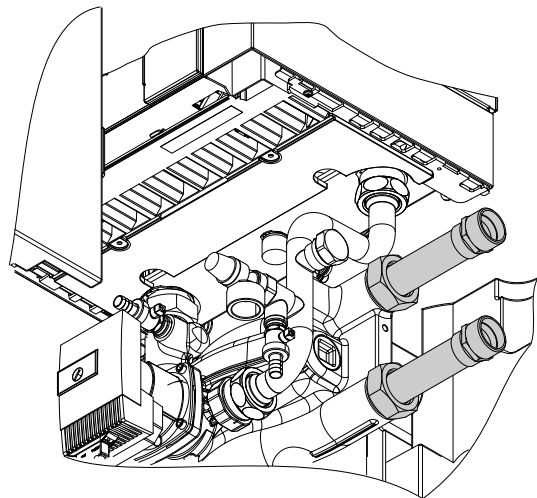
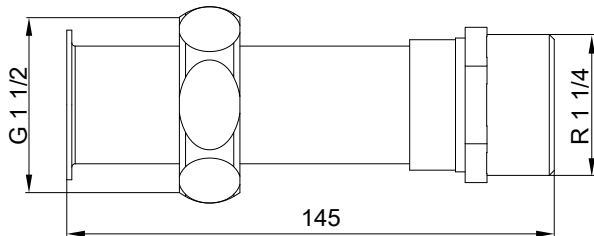

### Connection accessories for installation to the top/bottom

**Part no. ZK03675**

For combination with the connection set for heating circuit with high efficiency circulation pump and low loss header.

Components:

- 2 pipe bends R 1¼ (male thread)

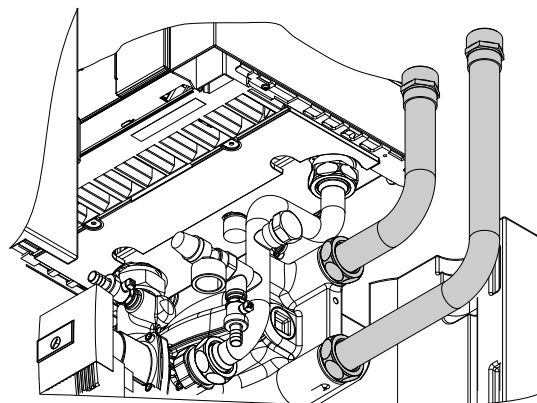

## Installation accessories (cont.)

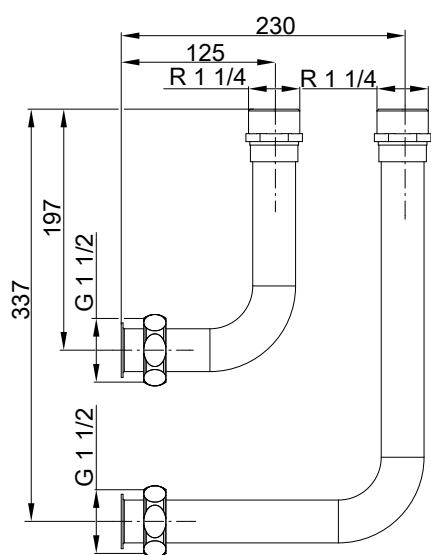

### Dual sensor well for combination of Vitodens 200-W with heat pump

**Part no. ZK03672**

For installation in the heating circuit connection set, for positioning a second flow temperature sensor.

For combination with the connection set for heating circuit with high efficiency circulation pump and low loss header.

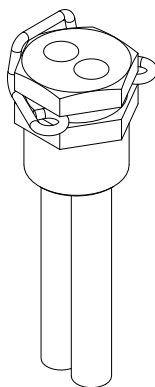

### Wall mounting bracket

**Part no. ZK03677**

For combination with the connection set for heating circuit with variable speed high efficiency circulation pump and low loss header.

Only required for installations without mounting frame.

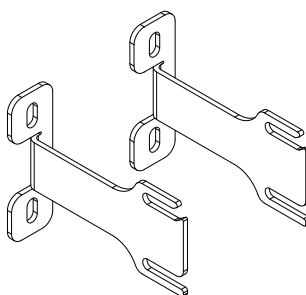

### Mounting frame

**Part no. ZK03678**

For combination with the connection set for heating circuit with high efficiency circulation pump and low loss header.

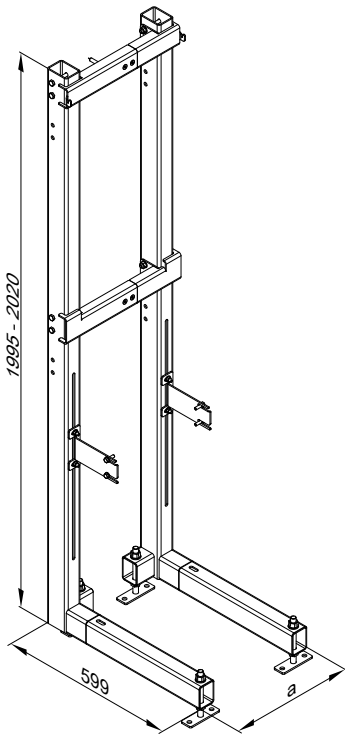

a Adjustable to appliance width

**Immersion temperature sensor (for low loss header)**

**Part no. 7179488**  
To capture the low loss header temperature.

Additional sensor for dual sensor well. **For dual mode or multi mode heating systems.**

**CO limiter**

Monitoring device for safety shutdown of the boiler in the event of escaping carbon monoxide.  
Wall mounting in the ceiling area near the boiler.

CO limiter for boiler	Part no.
Vitoladens 300-C	<b>Z015500</b>
Vitorondens 200-T up to 55 kW, Vitoladens 300-T	<b>Z021823</b>
Vitodens 200	<b>Z024247</b>
Vitocrossal 200, type C1B	
Vitocrossal 300	
Vitocrossal 300, type C13	
Vitorondens 200-T, type J2RA	

Components:

- Casing with
  - Integral CO sensor
  - Mode, fault and alarm indicators
  - Acoustic alarm system
- Communication cable for interface (2.5 m)
- Interface inside the casing with power cable (1.2 m) and connecting lead for burner shutdown relay (1.2 m)
- Fixing materials
- For Vitoladens 300-T and Vitorondens 200-T, including connecting cable for connection to the corresponding boiler

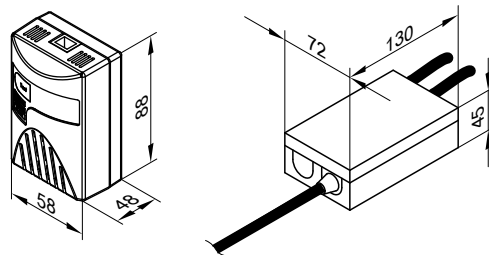

**Specification**

Rated voltage	230 V~
Rated frequency	50 Hz
Power consumption	2 W
Rated breaking capacity of the relay output	8 A 230 V~
Alarm threshold	55 ppm CO to EN 50291-1
Protection class	II
IP rating	IP 20 to EN 60529; ensure through design/installation.
Permissible ambient temperature	0 °C to 40 °C

### 2.3 Installation accessories for Vitodens 200-W, 120 and 150 kW

#### Heating circuit connection set with variable speed high efficiency circulation pump and low loss header

Part no. ZK03664

Connections G 2 (male thread)

Components:

- Boiler drain & fill valve
- Safety valve 6 bar (0.6 MPa)
- Variable speed high efficiency circulation pump
- Straight-through gas valve with integral, thermally activated safety shut-off valve Rp 1
- Low loss header with immersion temperature sensor
- Quick-action air vent valve
- Connection G 1 (male thread) for diaphragm expansion vessel
- Thermal insulation

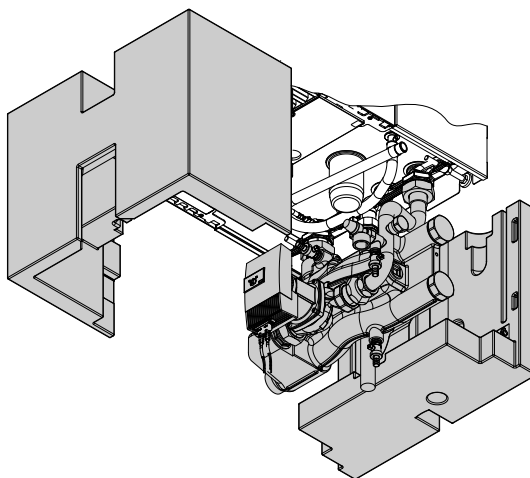

#### Connection set for heating circuit with high efficiency circulation pump for combination with external system separation or heating water buffer cylinder

Part no. 7501323

Connections G 2 (male thread)

Components:

- Variable speed high efficiency circulation pump
- Tee
- Non-return valve
- Boiler drain & fill valve
- Gas shut-off valve with integral thermally activated safety shut-off valve Rp 1

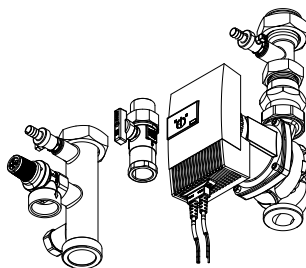

#### DHW cylinder connection set

Part no. ZK03670

For combination with the connection set for heating circuit with high efficiency circulation pump and low loss header.

Components:

- 2 tees G 2 (male thread)

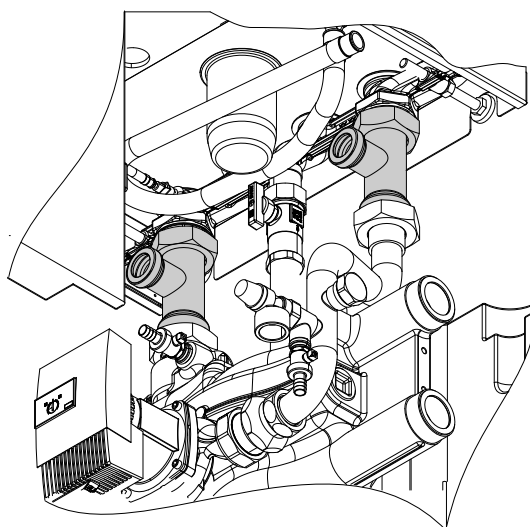
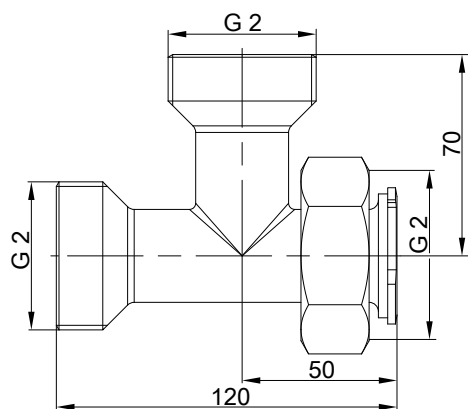

## Installation accessories (cont.)

### Connection set for combination of Vitodens 200-W with CHP unit

**Part no. ZK03671**

For combination with the connection set for heating circuit with high efficiency circulation pump and low loss header. For connection of the CHP unit return downstream of the low loss header.

Components:

- Tee G 2

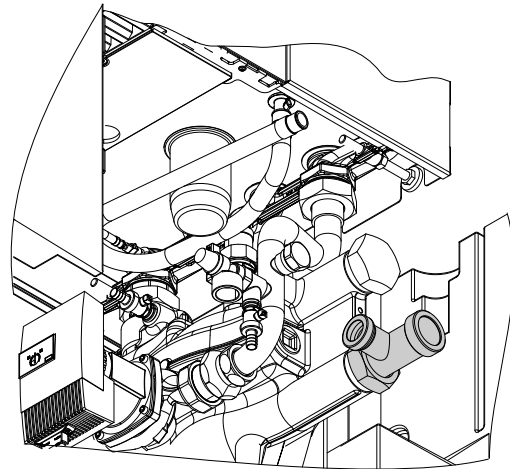
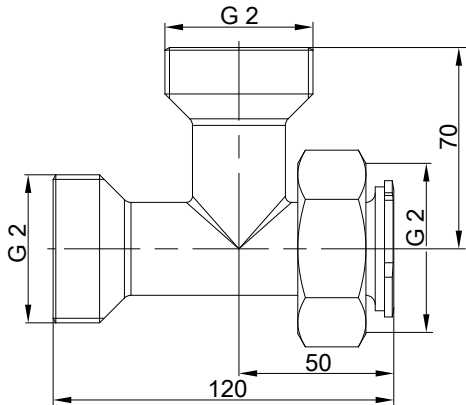

### Connection accessories for installation to the left/right

**Part no. ZK03674**

For combination with the connection set for heating circuit with high efficiency circulation pump and low loss header.

Components:

- 2 pipe sections R 1½ (male thread)

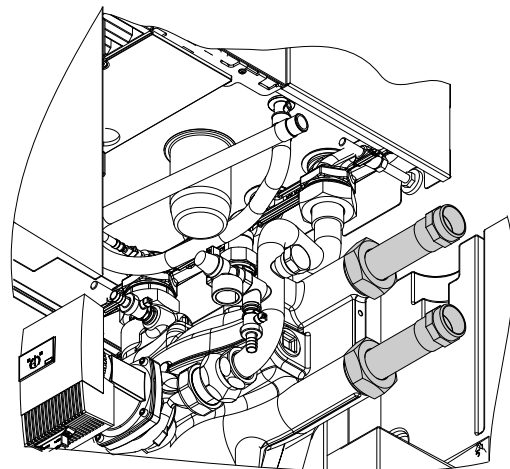
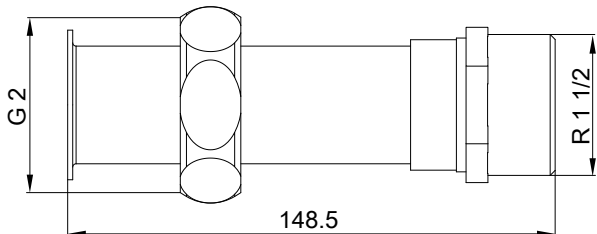

### Connection accessories for installation to the top/bottom

**Part no. ZK03676**

For combination with the connection set for heating circuit with high efficiency circulation pump and low loss header.

Components:

- 2 pipe bends R 1½ (male thread)

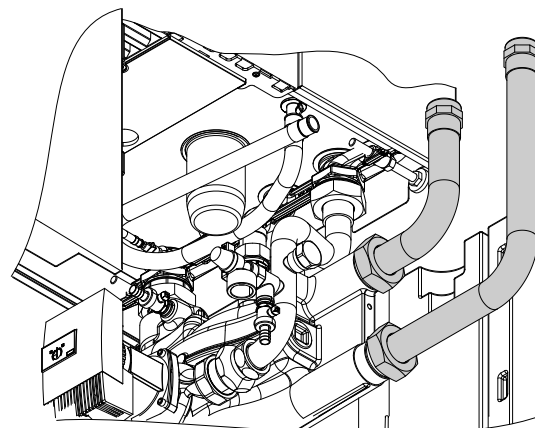

## Installation accessories (cont.)

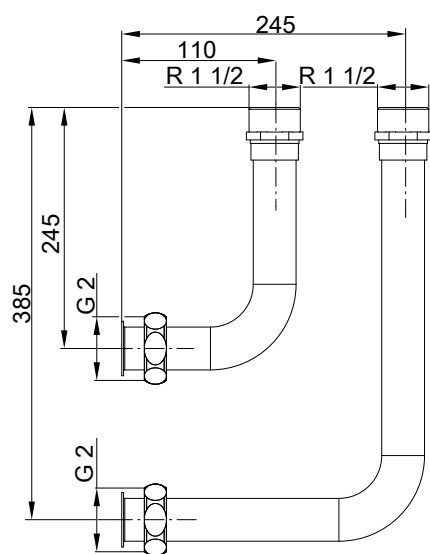

### Dual sensor well for combination of Vitodens 200-W with heat pump

**Part no. ZK03672**

For installation in the heating circuit connection set, for positioning a second flow temperature sensor.

For combination with the connection set for heating circuit with high efficiency circulation pump and low loss header.

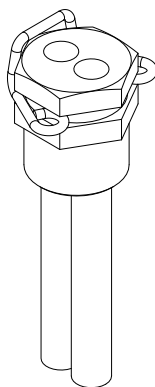

### Wall mounting bracket

**Part no. ZK03677**

For combination with the connection set for heating circuit with variable speed high efficiency circulation pump and low loss header.

Only required for installations without mounting frame.

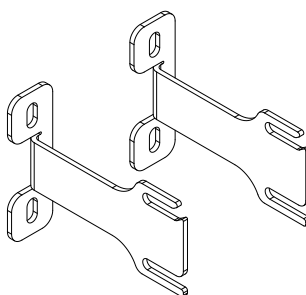

### Mounting frame

**Part no. ZK03678**

For combination with the connection set for heating circuit with high efficiency circulation pump and low loss header.

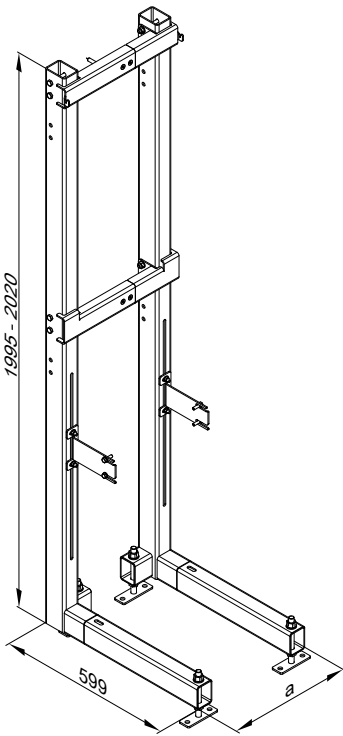

a Adjustable to appliance width

### Immersion temperature sensor (for low loss header)

**Part no. 7179488**

To capture the low loss header temperature.

Additional sensor for dual sensor well. **For dual mode or multi mode heating systems.**

## 2.4 Divicon heating circuit distributor

### Design and function

- Available with connections R ¾, R 1 and R 1¼
- With heating circuit pump, check valve, ball valves with integral thermometers and 3-way mixer or without mixer
- Quick and simple installation due to pre-assembled unit and compact design
- All-round thermal insulation shells for low radiation losses
- High efficiency circulation pumps and optimised mixer curve ensure low electricity costs and precise control characteristics
- Individually wall mounted or with a double or triple manifold
- $K_V$  values of mixer can be adjusted in 5 stages

### Divicon with mixer

The Divicon with mixer is available with the following equipment components in various combinations to suit the respective boiler:

- Wilo or Grundfos high efficiency circulation pumps
- Mixer extension kits for connection to PlusBus or KM-BUS
- Without an extension kit for direct connection of the mixer motor to the boiler control unit
- NTC 10 kΩ or Pt1000 flow temperature sensors

### Note

A Divicon with mixer comes with the mixer motor as part of the standard delivery. This mixer motor is mounted directly on the mixer.

For part numbers in conjunction with the different equipment components, see the Viessmann pricelist.

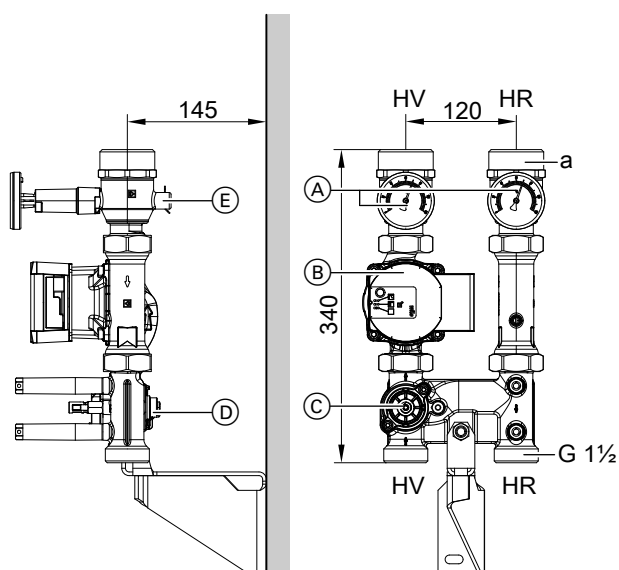

Divicon with mixer: Wall mounting, shown without thermal insulation, mixer motor and mixer extension kit

- HR Heating return
- HV Heating flow
- (A) Ball valves with thermometer (as operating element)
- (B) Circulation pump
- (C) Mixer
- (D) Setting lever for  $K_V$  value of the mixer; with setting scale in accordance with the following table
- (E) Sensor well for flow temperature sensor

### Specification – Divicon with mixer

Heating circuit connections	R ¾	R 1	R 1¼
Nominal diameter	DN 20	DN 25	DN 32
Max. flow rate	1.0 m³/h	1.5 m³/h	2.5 m³/h
a (female)	Rp ¾	Rp 1	Rp 1¼
a (male)	G 1¼	G 1¼	G 2
Adjustable $K_V$ values for mixer: Values in m³/h for a pressure drop of 1 bar (0.1 MPa)	3.1	4.0	4.7
	3.7	4.5	5.1
	4.5	5.1	5.6
	4.8	5.5	5.8
	4.9	5.6	5.9
Max. operating pressure	3 bar (0.3 MPa)	3 bar (0.3 MPa)	3 bar (0.3 MPa)
Max. operating temperature at 40 °C ambient temperature	80 °C	80 °C	80 °C
Permiss. ambient temperature	0 to 40 °C		
	– Storage –20 to 40 °C		
Electrical values			
– Rated voltage	230 V	230 V	230 V
– Rated frequency	50 Hz	50 Hz	50 Hz
– Connected load with Wilo circulation pump	43 W	43 W	60 W
– Connected load with Grundfos circulation pump	39 W	39 W	52 W
– Connected load, extension kit	6 W	6 W	6 W
Mixer motor			
– Type	ESBE ARA561		
– Runtime	120 s	120 s	120 s
Weight with Wilo circulation pump			
– Without mixer extension kit	6.9 kg	6.9 kg	7.4 kg
– With mixer extension kit	8.1 kg	8.1 kg	8.7 kg
Weight with Grundfos circulation pump			
– Without mixer extension kit	7.0 kg	7.0 kg	7.4 kg
– With mixer extension kit	8.2 kg	8.2 kg	8.7 kg

### Note

Pressure drop curves of the Divicon for different  $K_V$  values of mixer: See chapter "Pressure drop graphs".

### Divicon without mixer

The Divicon without mixer is available with different high efficiency circulation pumps.



## Installation accessories (cont.)

For part numbers in conjunction with different circulation pumps, see the Viessmann pricelist.

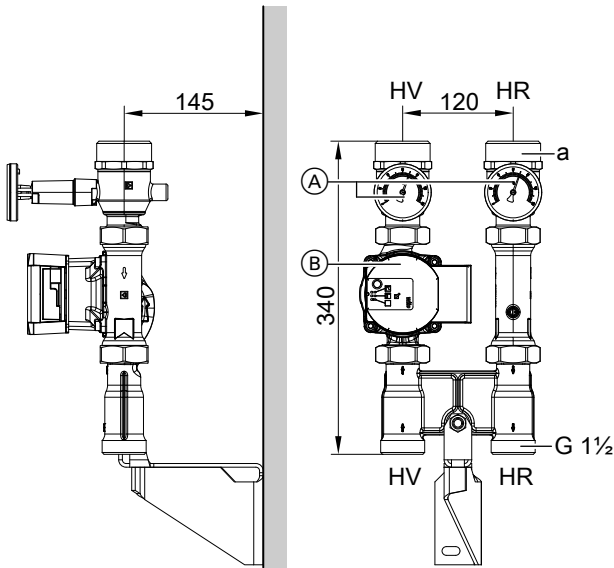

Divicon without mixer: Wall mounting, shown without thermal insulation

- HR Heating return
- HV Heating flow
- (A) Ball valves with thermometer (as operating element)
- (B) Circulation pump

### Specification – Divicon without mixer

Heating circuit connections	R 3/4	R 1	R 1 1/4
Nominal diameter	DN 20	DN 25	DN 32
Max. flow rate	1.0 m <sup>3</sup> /h	1.5 m <sup>3</sup> /h	2.5 m <sup>3</sup> /h
a (female)	Rp 3/4	Rp 1	Rp 1 1/4
a (male)	G 1 1/4	G 1 1/4	G 2
Max. operating pressure	3 bar (0.3 MPa)	3 bar (0.3 MPa)	3 bar (0.3 MPa)
Max. operating temperature at 40 °C ambient temperature	80 °C	80 °C	80 °C
Permissible ambient temperature			
– Operation	0 to 40 °C		
– Storage	–20 to 40 °C		
Electrical values			
– Rated voltage	230 V	230 V	230 V
– Rated frequency	50 Hz	50 Hz	50 Hz
– Connected load with Wilo circulation pump	43 W	43 W	60 W
– Connected load with Grundfos circulation pump	39 W	39 W	52 W
Weight with Wilo circulation pump	6.1 kg	6.1 kg	6.7 kg
Weight with Grundfos circulation pump	6.2 kg	6.2 kg	6.7 kg

### Installation example: Divicon with double manifold

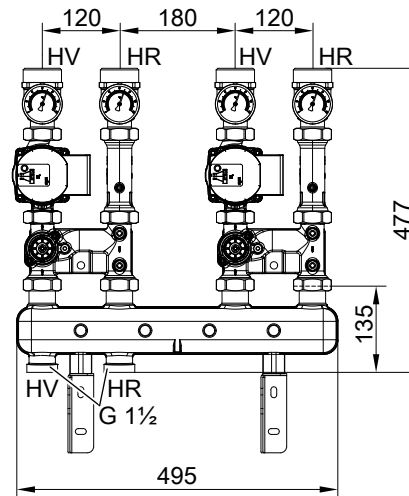

Diagram without thermal insulation

- HR Heating return
- HV Heating flow

### Installation example: Divicon with triple manifold

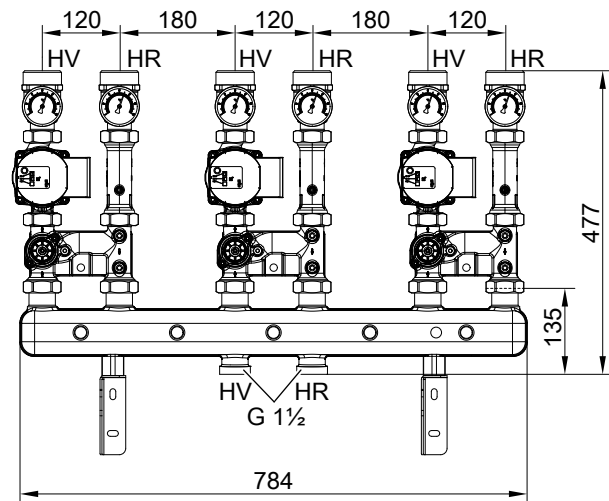
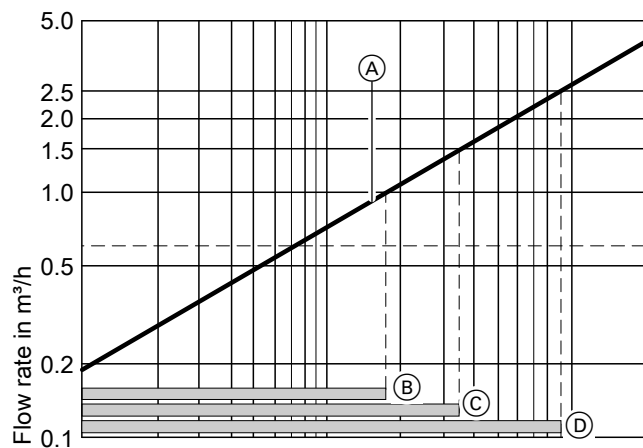

Diagram without thermal insulation

- HR Heating return
- HV Heating flow

## Determining the required nominal diameter



Mixer control characteristics

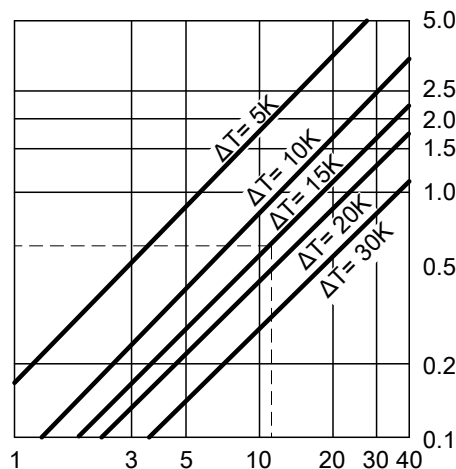

Heating circuit output in kW

- (A) Divicon with mixer  
The operating ranges marked (B) to (D) provide optimum control characteristics with the Divicon mixer:
- (B) Divicon with mixer DN 20 (R ¾)  
Operating range: 0 to 1.0 m³/h

- (C) Divicon with mixer DN 25 (R 1)  
Operating range: 0 to 1.5 m³/h
- (D) Divicon with mixer DN 32 (R 1¼)  
Operating range: 0 to 2.5 m³/h

### Example:

Heating circuit for radiators with a heating output of  $\dot{Q} = 11.6$  kW  
Heating system temperature 75/60 °C ( $\Delta T = 15$  K)

- c Specific thermal capacity
- $\dot{m}$  Mass flow rate
- $\dot{Q}$  Heating output
- $\dot{V}$  Flow rate

$$\dot{Q} = \dot{m} \cdot c \cdot \Delta T \quad c = 1.163 \frac{\text{Wh}}{\text{kg} \cdot \text{K}} \quad \dot{m} \hat{=} \dot{V} \quad (1 \text{ kg} \approx 1 \text{ dm}^3)$$

$$\dot{V} = \frac{\dot{Q}}{c \cdot \Delta T} = \frac{11600 \text{ W} \cdot \text{kg} \cdot \text{K}}{1.163 \text{ Wh} \cdot (75-60) \text{ K}} = 665 \frac{\text{kg}}{\text{h}} \hat{=} 0.665 \frac{\text{m}^3}{\text{h}}$$

With value  $\dot{V}$ , select the smallest possible mixer within the application limit.

Result for this example: Divicon with mixer DN 20 (R ¾)

### Circulation pump curves

The residual head of the circulation pump is derived from the differential between the selected pump curve and the pressure drop curve of the relevant Divicon and/or other components (pipe assembly, distributor, etc.).

The pressure drop curves of the different Divicon for the respective max.  $K_{VS}$  value of the mixer are also shown in the following pump curves.

Heating circuit connections	R ¾	R 1	R 1¼
Nominal diameter	DN 20	DN 25	DN 32
Max. flow rate	1.0 m³/h	1.5 m³/h	2.5 m³/h

### Example:

Flow rate  $\dot{V} = 0.665$  m³/h

### Selected:

- Divicon with mixer DN 20
- Wilo PARA 25/6 circulation pump, variable differential pressure operating mode and set to maximum delivery head
- Pump rate 0.7 m³/h

Head according to pump curve: 48 kPa  
Divicon pressure drop: 3.5 kPa  
Residual head: 48 kPa – 3.5 kPa = 44.5 kPa.

### Note

For further components (pipe assembly, distributor, etc.) determine the pressure drop and deduct it from the residual head.

### Differential pressure-dependent heating circuit pumps

According to the [German] Buildings Energy Act (GEG), circulation pumps in central heating systems must be sized in accordance with current technical rules.

Ecodesign Directive 2009/125/EC requires high efficiency circulation pumps to be used throughout Europe from 1 January 2013, if these pumps are not installed in the heat generator.

### Design information

The use of differential pressure-dependent heating circuit pumps requires heating circuits with variable pump rates, e.g. single-line and twin-line heating systems with thermostatic valves and under-floor heating systems with thermostatic valves or zone valves.

## Installation accessories (cont.)

### Wilo Para 25/6

- Particularly power saving, high efficiency circulation pump
- Energy efficiency index  $EEl \leq 0.20$

#### Operating mode: Constant differential pressure

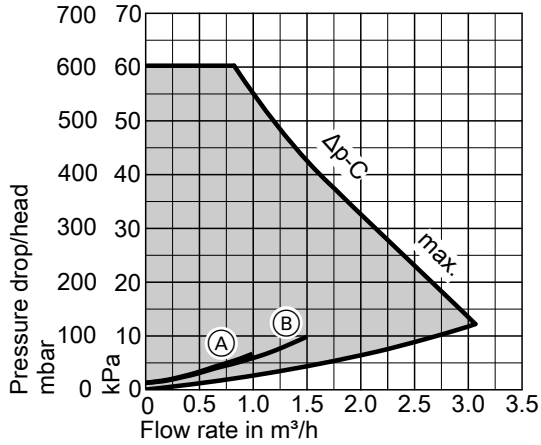

- (A) Pressure drop curve Divicon with mixer DN 20 with  $K_{VS}$  4.9
- (B) Pressure drop curve Divicon with mixer DN 25 with  $K_{VS}$  5.6

#### Operating mode: Variable differential pressure

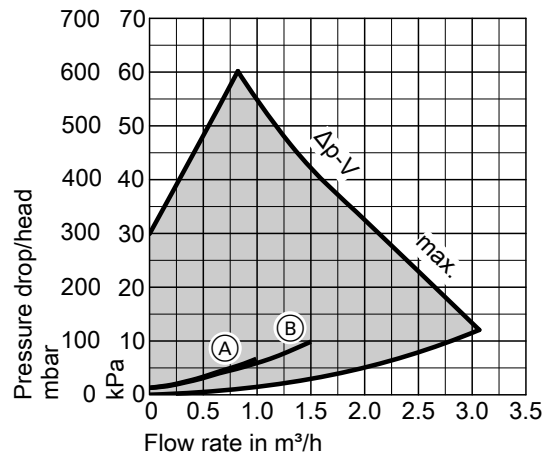

- (A) Pressure drop curve Divicon with mixer DN 20 with  $K_{VS}$  4.9
- (B) Pressure drop curve Divicon with mixer DN 25 with  $K_{VS}$  5.6

### Wilo Para 25/8

- Energy efficiency index  $EEl \leq 0.20$

#### Operating mode: Constant differential pressure

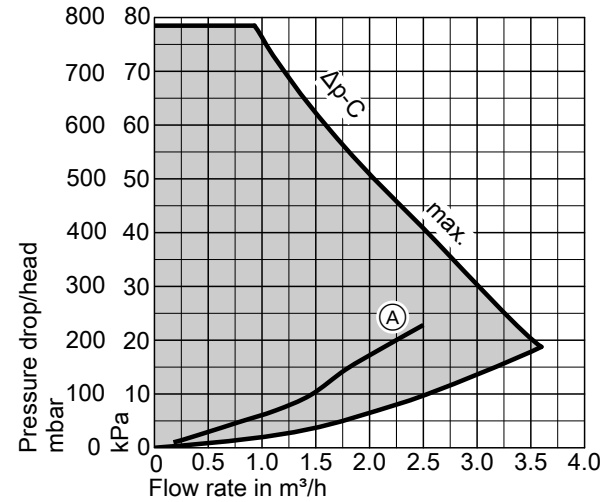

- (A) Pressure drop curve Divicon with mixer DN 32 with  $K_{VS}$  5.9

#### Operating mode: Variable differential pressure

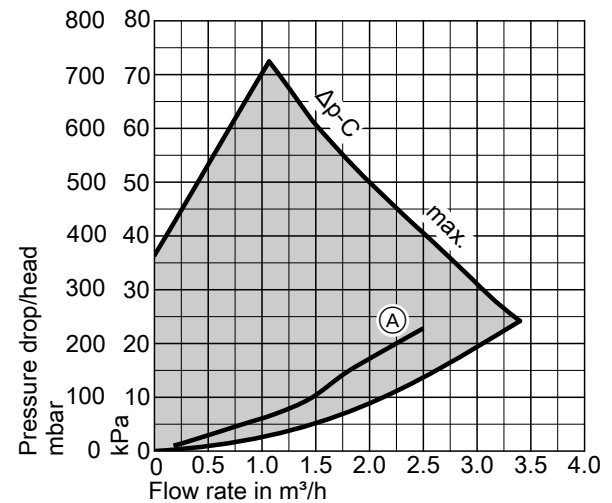

- (A) Pressure drop curve Divicon with mixer DN 32 with  $K_{VS}$  5.9

## Installation accessories (cont.)

### Grundfos UPM3S 25-60

- With power consumption display
- With Autoadapt function (automatic matching to the pipework)
- Energy efficiency index  $EEI \leq 0.20$

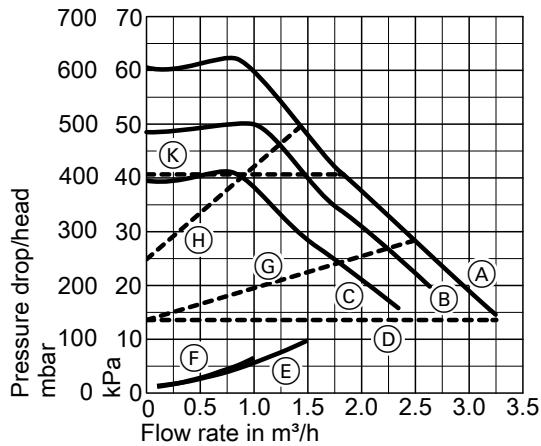

- (A) Level 3
- (B) Level 2
- (C) Level 1
- (D) Min. constant pressure
- (E) Pressure drop curve Divicon with mixer DN 25 with  $K_{VS}$  5.6
- (F) Pressure drop curve Divicon with mixer DN 20 with  $K_{VS}$  4.9
- (G) Min. proportional pressure
- (H) Max. proportional pressure
- (K) Max. constant pressure

### Grundfos UPM3S 25-70

- With power consumption display
- With Autoadapt function (automatic matching to the pipework)
- Energy efficiency index  $EEI \leq 0.20$

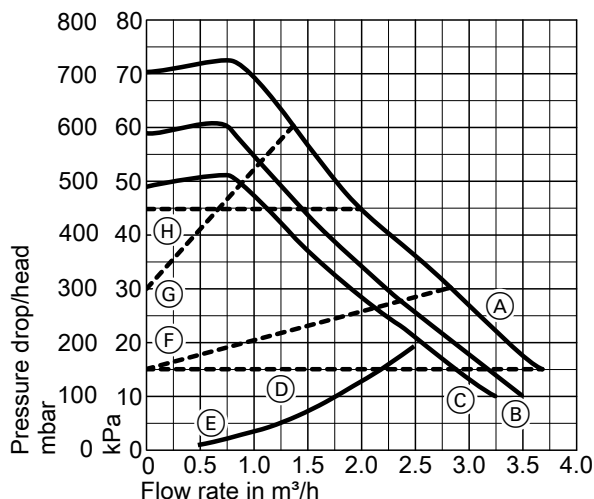

- (A) Level 3
- (B) Level 2
- (C) Level 1
- (D) Min. constant pressure
- (E) Pressure drop curve Divicon with mixer DN 32 with  $K_{VS}$  5.9
- (F) Min. proportional pressure
- (G) Max. proportional pressure
- (H) Max. constant pressure

### Pressure drop graphs

#### Note

- All diagrams refer to the respective Divicon with mixer, without manifold.
- Each individual curve shows the pressure drop curve for the  $K_V$  value of the mixer selected on the setting lever.

#### Divicon with mixer DN 20

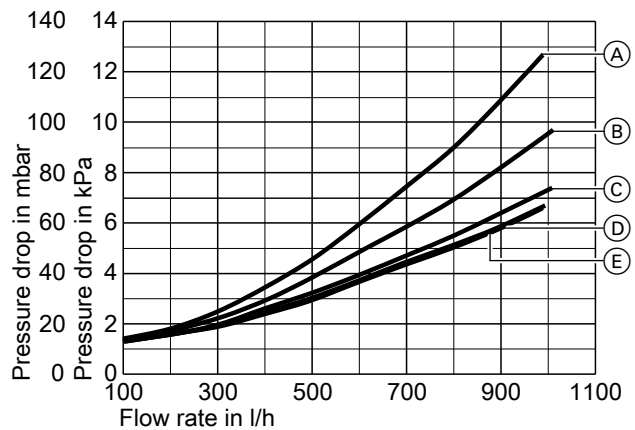

#### With circulation pump Wilo PARA 25/6

- (A)  $K_V$  3.1
- (B)  $K_V$  3.7
- (C)  $K_V$  4.5
- (D)  $K_V$  4.8
- (E)  $K_{VS}$  4.9

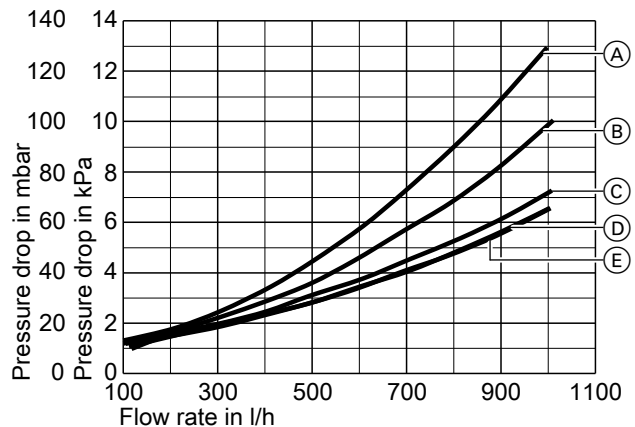

#### With circulation pump Grundfos UPM3S 25-60

- (A)  $K_V$  3.1
- (B)  $K_V$  3.7
- (C)  $K_V$  4.5
- (D)  $K_V$  4.8
- (E)  $K_{VS}$  4.9

## Installation accessories (cont.)

### Divicon with mixer DN 25

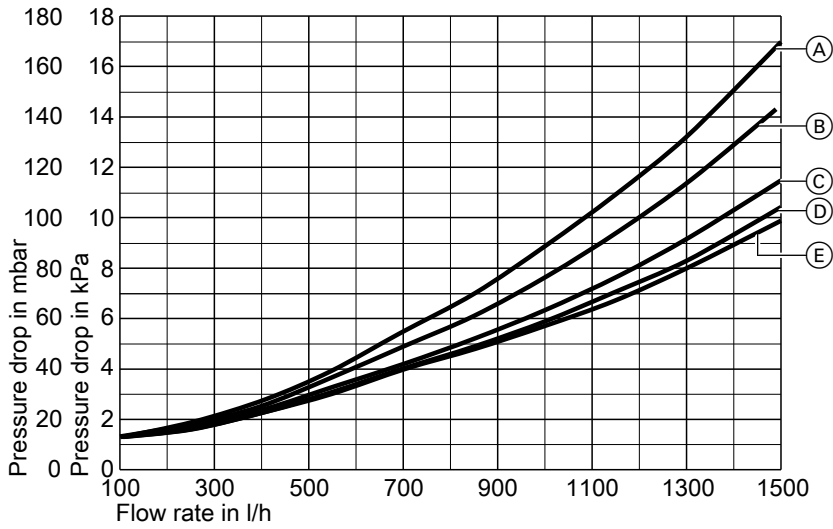

### With circulation pump Wilo PARA 25/6

- |             |                |
|-------------|----------------|
| Ⓐ $K_v$ 4.0 | Ⓓ $K_v$ 5.5    |
| Ⓑ $K_v$ 4.5 | Ⓔ $K_{vs}$ 5.6 |
| Ⓒ $K_v$ 5.1 |                |

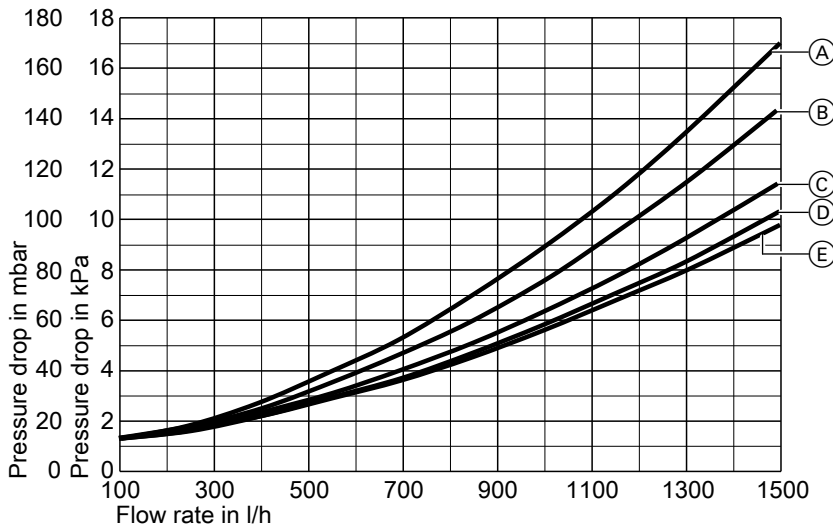

### With circulation pump Grundfos UPM3S 25-60

- |             |                |
|-------------|----------------|
| Ⓐ $K_v$ 4.0 | Ⓓ $K_v$ 5.5    |
| Ⓑ $K_v$ 4.5 | Ⓔ $K_{vs}$ 5.6 |
| Ⓒ $K_v$ 5.1 |                |

## Installation accessories (cont.)

### Divicon with mixer DN 32

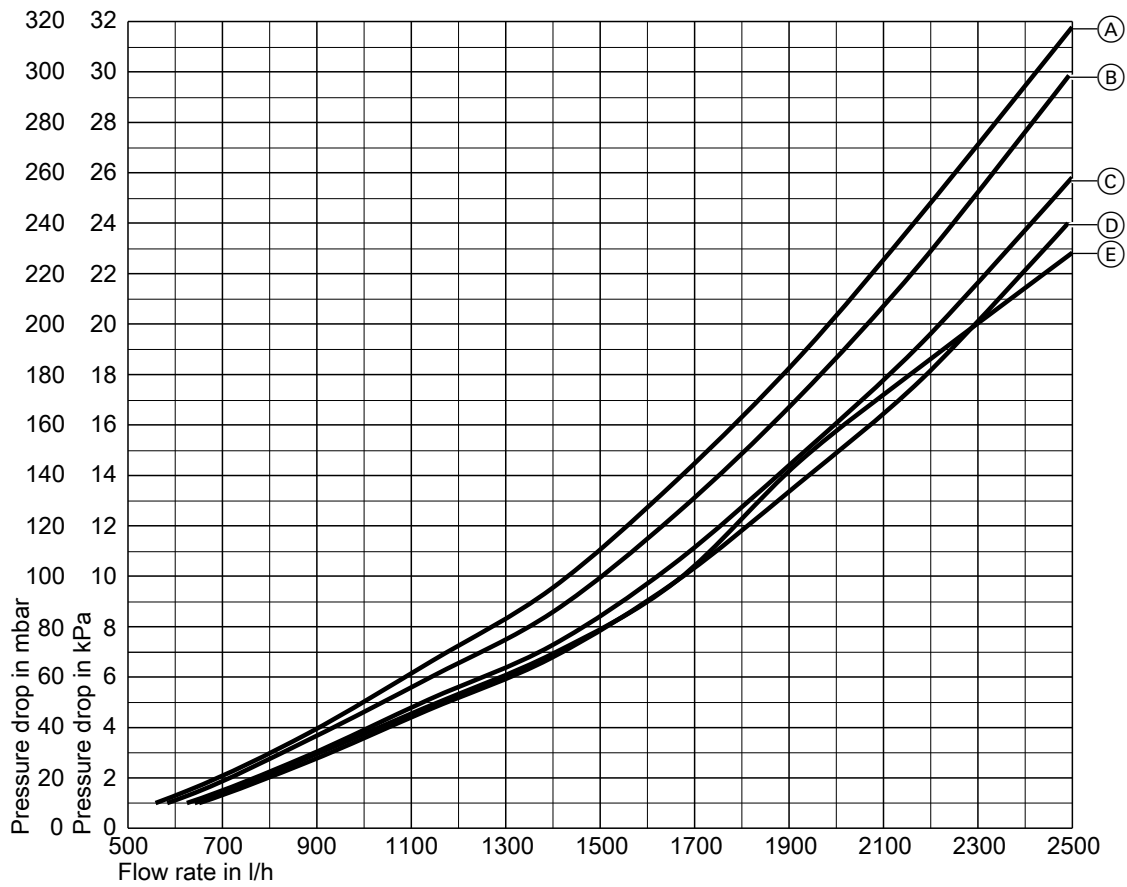

### With circulation pump Wilo PARA 25/8

- Ⓐ  $K_v$  4.7
- Ⓑ  $K_v$  5.1
- Ⓒ  $K_v$  5.6
- Ⓓ  $K_v$  5.8
- Ⓔ  $K_{vs}$  5.9

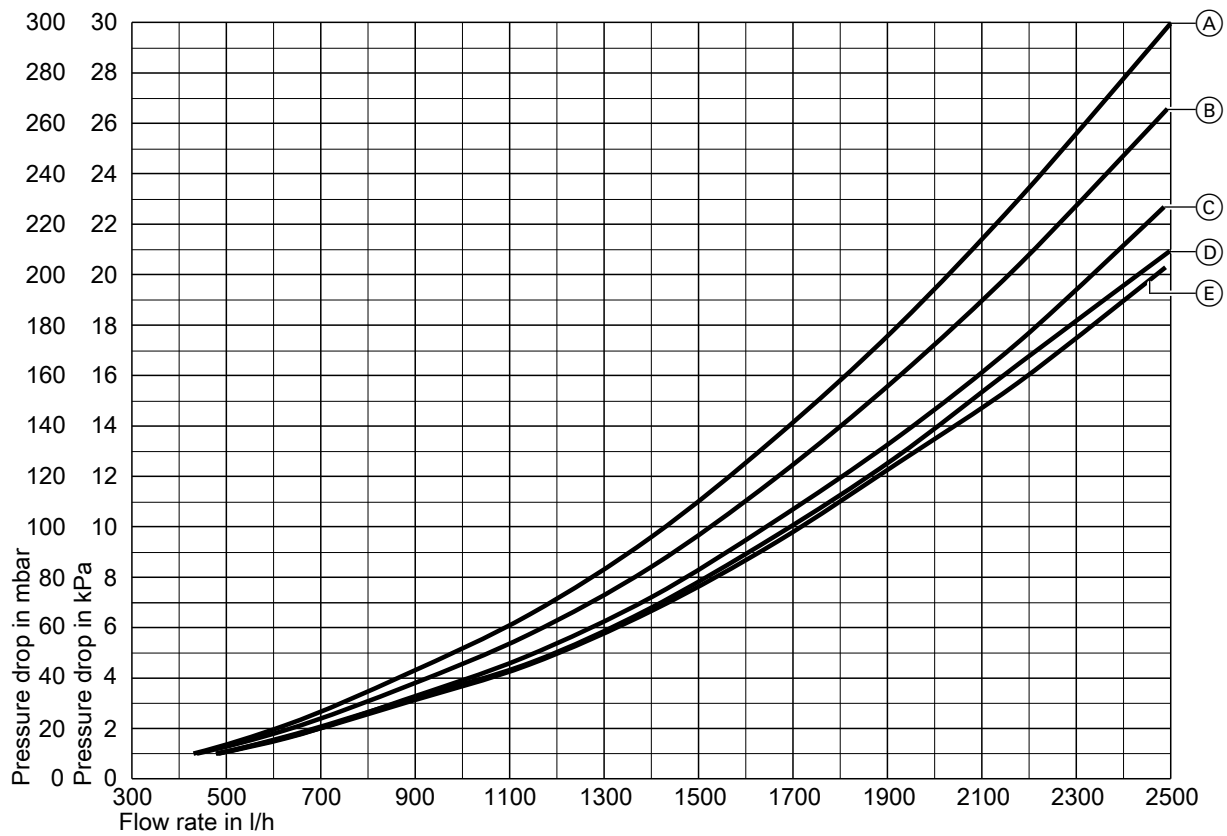

With circulation pump Grundfos UPM3K 25-70

- (A)  $K_V$  4.7
- (B)  $K_V$  5.1
- (C)  $K_V$  5.6
- (D)  $K_V$  5.8
- (E)  $K_{VS}$  5.9

**Residual heads**

**Note**

All diagrams refer to the respective Divicon with mixer, without manifold.

**Divicon with mixer DN 20**

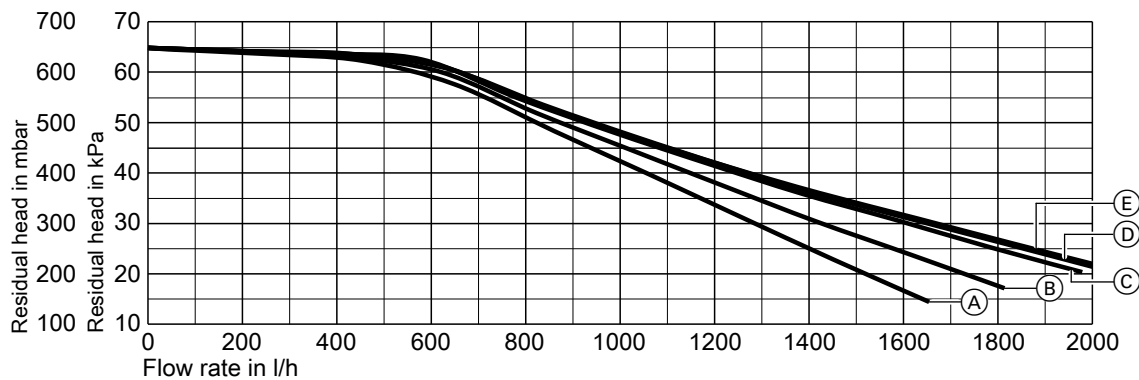

With circulation pump Wilo PARA 25/6

- (A)  $K_V$  3.1
- (B)  $K_V$  3.7
- (C)  $K_V$  4.5

5822432



## Installation accessories (cont.)

- Ⓓ  $K_V$  4.8
- Ⓔ  $K_{VS}$  4.9

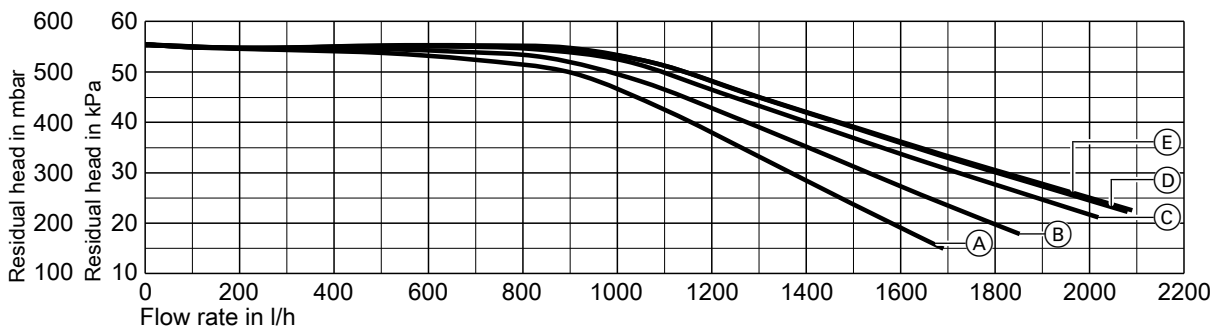

With circulation pump Grundfos UPM3S 25-60

- Ⓐ  $K_V$  3.1
- Ⓑ  $K_V$  3.7
- Ⓒ  $K_V$  4.5
- Ⓓ  $K_V$  4.8
- Ⓔ  $K_{VS}$  4.9

Divicon with mixer DN 25

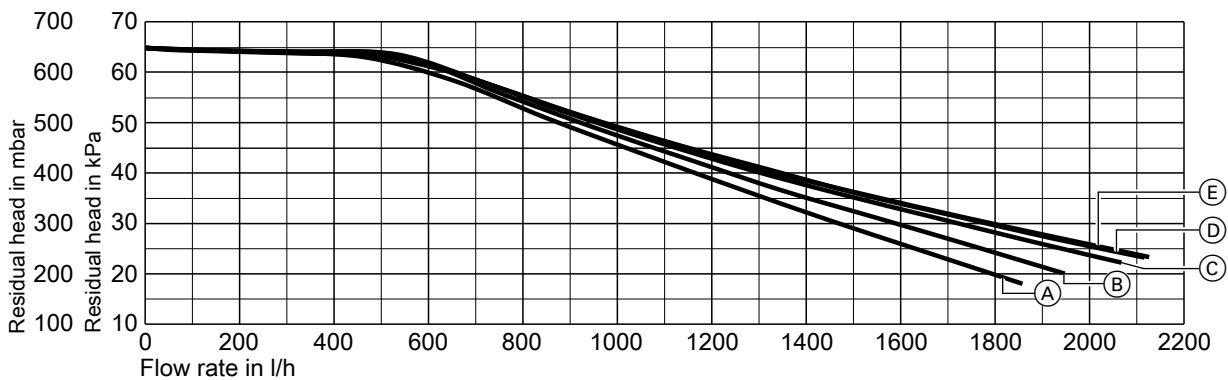

With circulation pump Wilo PARA 25/6

- Ⓐ  $K_V$  4.0
- Ⓑ  $K_V$  4.5
- Ⓒ  $K_V$  5.1
- Ⓓ  $K_V$  5.5
- Ⓔ  $K_{VS}$  5.6

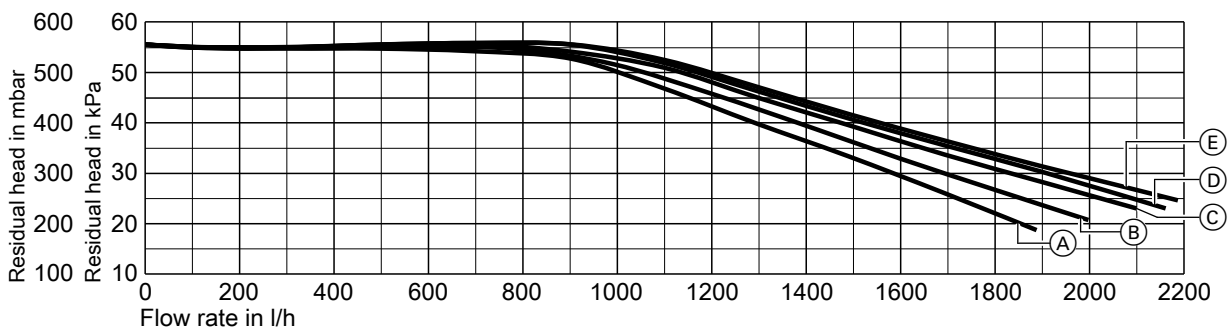

With circulation pump Grundfos UPM3S 25-60

- Ⓐ  $K_V$  4.0
- Ⓑ  $K_V$  4.5
- Ⓒ  $K_V$  5.1





## Installation accessories (cont.)

- Ⓓ  $K_V$  5.5
- Ⓔ  $K_{VS}$  5.6

### Divicon with mixer DN 32

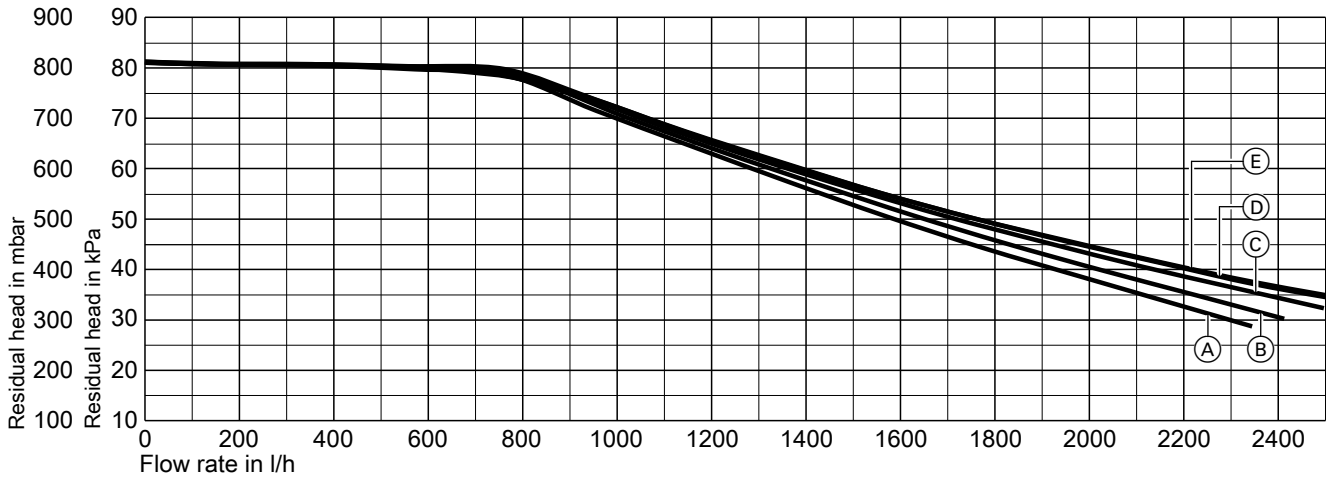

### With circulation pump Wilo PARA 25/8

- Ⓐ  $K_V$  4.7
- Ⓑ  $K_V$  5.1
- Ⓒ  $K_V$  5.6
- Ⓓ  $K_V$  5.8
- Ⓔ  $K_{VS}$  5.9

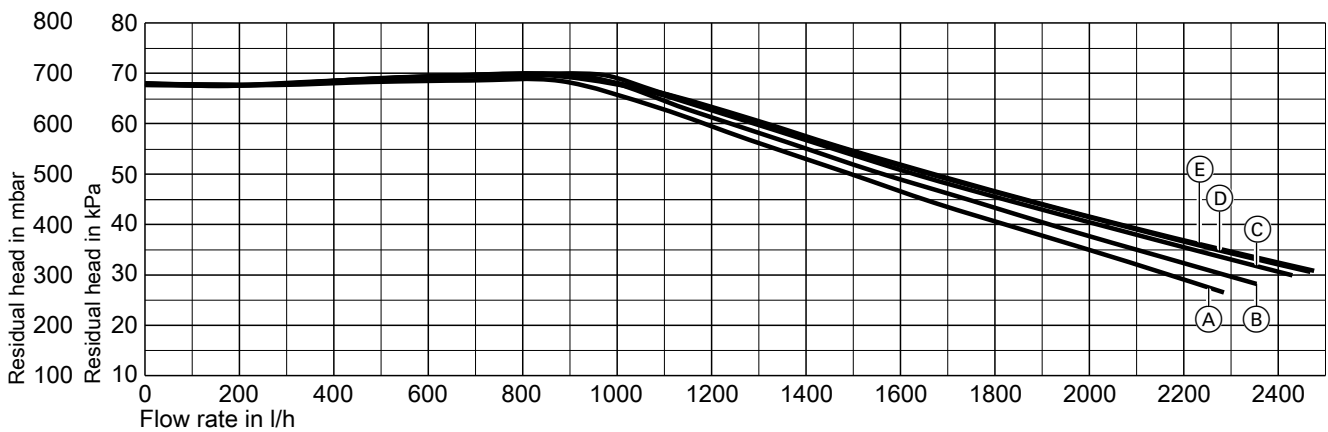

### With circulation pump Grundfos UPM3K 25-70

- Ⓐ  $K_V$  4.7
- Ⓑ  $K_V$  5.1
- Ⓒ  $K_V$  5.6
- Ⓓ  $K_V$  5.8
- Ⓔ  $K_{VS}$  5.9

## Cable set with plugs 40 and 145

### Part no. 7424960

For connecting the mixer PCBs with 2 heating circuits with mixer

The connecting cable included in standard delivery of the extension kits with mixer is replaced with the cable set with plugs 40 and 145.

Wall mounting bracket for individual Divicons

Part no. 7465894  
With screws and rawl plugs

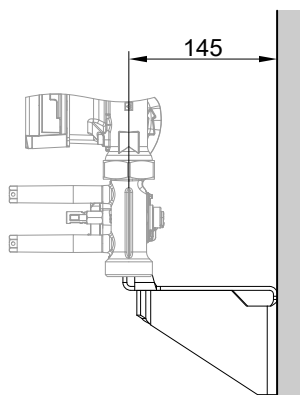

Manifold for 2 Divicons

Part no. 7986761  
 ■ Incl. thermal insulation  
 ■ Wall mounted with separate wall mounted bracket (accessories)  
 ■ Establish connection between the boiler and manifold on site.

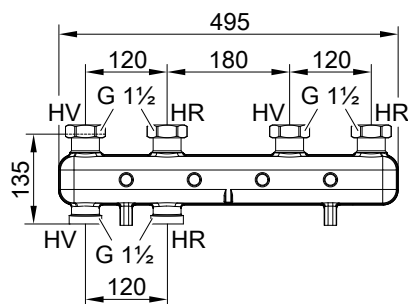

HV Heating water flow  
HR Heating water return

Pressure drop graph

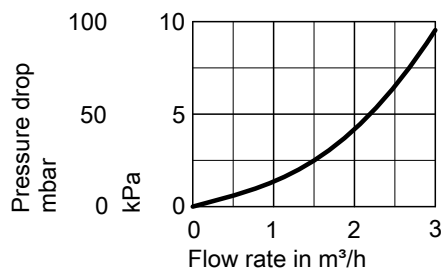

**Note**  
The curve only relates to 1 connector pair (HV/HR) for connecting the Divicon.

Manifold for 3 Divicons

Part no. 7986762  
 ■ Incl. thermal insulation  
 ■ Wall mounted with separate wall mounted bracket (accessories)  
 ■ Establish connection between the boiler and manifold on site.

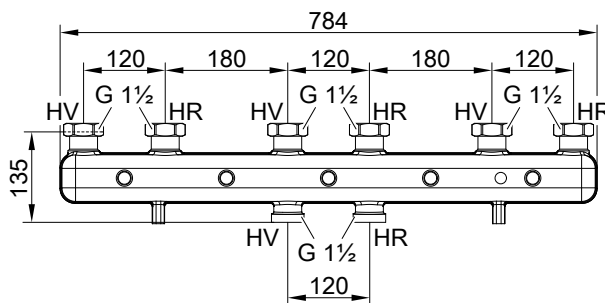

HV Heating water flow  
HR Heating water return

## Installation accessories (cont.)

### Pressure drop graph

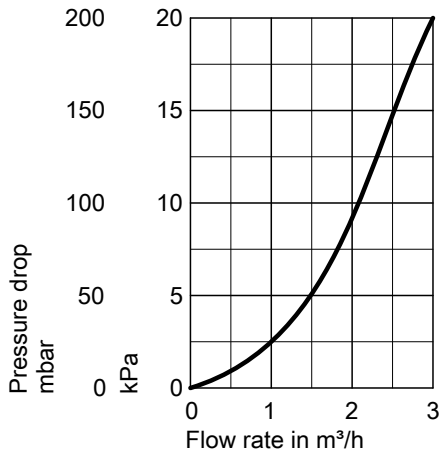

### Note

The curve only relates to 1 connector pair (HV/HR) for connecting the Divicon.

### Wall mounting bracket for manifold

#### Part no. 7465439

With screws and rawl plugs

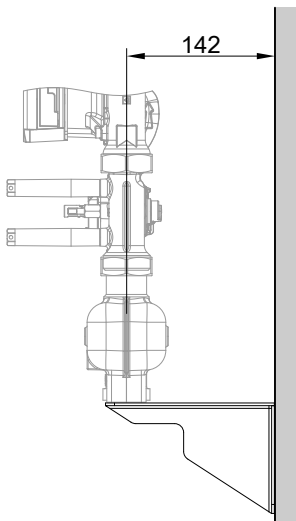

## 2.5 Installation accessories for multi boiler systems

### Hydraulic cascades

#### Low loss header DN 80

Can be used for total heating outputs of up to 594 kW

Part no. ZK02627

Comprising:

- Low loss header with integral sensor well
- Thermal insulation
- Quick-action air vent valve
- Ball valve with hose nozzle for draining or blow-down
- Floor bracket

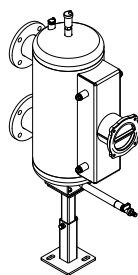

#### Cascade module adaptor DN 100

For connecting consumers if a low loss header is not used.

Part no. ZK02628

Comprising:

- Adaptor with connections for heating water flow and return
- Thermal insulation
- Quick-action air vent valve
- Ball valve with hose nozzle for draining or blow-down
- Retaining bracket

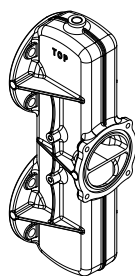

#### Adaptor flanges DN 80 to R 2

Can be used for total heating outputs of up to 200 kW in conjunction with a low loss header

Part no. 7456326

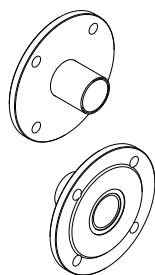

#### Adaptor flanges DN 100 to R 2

Can be used for total heating outputs of up to 200 kW in conjunction with a cascade module adaptor

Part no. ZK02629

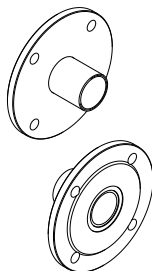

#### Pipe bends 90°

For corner installation, multi boiler system

Part no. ZK02630

Comprising:

- 2 pipe bends
- Thermal insulation
- Support

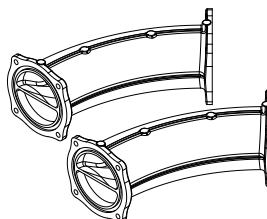

#### Condensate collectors

Comprising:

- Condensate collector with tee and brackets
- Drain hose for connecting to the drainage system
- Connection hose for condensate drain from trap
- Connection hose for draining the safety valve for each boiler

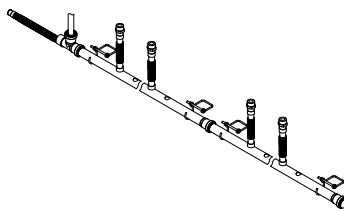

- Two-boiler system: Part no. ZK02631
- Three-boiler system: Part no. ZK02632
- Four-boiler system: Part no. ZK02633 (block or inline formation)
- Five-boiler system: Part no. ZK02634
- Six-boiler system: Part no. ZK02635 (block or inline formation)

### Flue gas cascades (positive pressure)

Comprising:

- Flue gas header
- Terminal with condensate drain and trap

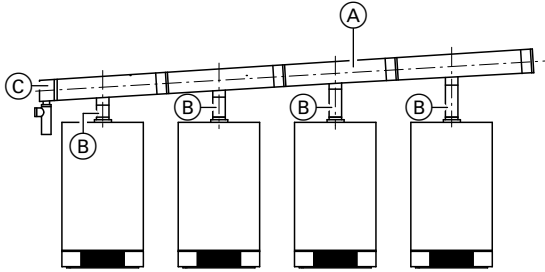

- (A) Flue gas header
- (B) Terminal with trap

- **Two-boiler system in inline formation**
  - For Vitodens 200-W, 49 and 60 kW: **Part no. ZK00675**
  - For Vitodens 200-W, 69 to 99 kW: **Part no. ZK00676**
- **Three-boiler system in inline formation**
  - For Vitodens 200-W, 49 and 60 kW: **Part no. ZK00678**
  - For Vitodens 200-W, 69 to 99 kW: **Part no. ZK00679**
- **Four-boiler system in inline formation**
  - For Vitodens 200-W, 49 and 60 kW: **Part no. ZK00681**
  - For Vitodens 200-W, 69 to 99 kW: **Part no. ZK00682**
- **Five-boiler system in inline formation**
  - For Vitodens 200-W, 49 and 60 kW: **Part no. ZK02636**
  - For Vitodens 200-W, 69 to 99 kW: **Part no. ZK02637**
- **Six-boiler system in inline formation**
  - For Vitodens 200-W, 49 and 60 kW: **Part no. ZK00684**
  - For Vitodens 200-W, 69 to 99 kW: **Part no. ZK00685**

- **Four-boiler system in block formation**
  - For Vitodens 200-W, 49 and 60 kW: **Part no. ZK00689**
  - For Vitodens 200-W, 69 to 99 kW: **Part no. ZK00690**
- **Six-boiler system in block formation**
  - For Vitodens 200-W, 49 and 60 kW: **Part no. ZK00691**
  - For Vitodens 200-W, 69 to 99 kW: **Part no. ZK00692**

For further specifications on the flue gas cascades, see the technical guide to Vitodens flue systems.

#### Note

When installing a flue gas cascade, a second flue gas back draught safety device for each boiler must be added to the order!

- **Back draught safety device for Vitodens 49 kW**

Comprising a back draught safety device DN 80 with coding card. For vertical installation in the continuing flue pipe, directly downstream of the boiler. Must be added to the order for every boiler in the flue gas cascade: **Part no. ZK07169**
- **Back draught safety device for Vitodens 60 kW**

Comprising a back draught safety device DN 80 with coding card. For vertical installation in the continuing flue pipe, directly downstream of the boiler. Must be added to the order for every boiler in the flue gas cascade: **Part no. ZK07170**
- **Back draught safety device for Vitodens 80 kW**

Comprising a back draught safety device DN 110 with coding card. For vertical installation in the continuing flue pipe, directly downstream of the boiler. Must be added to the order for every boiler in the flue gas cascade: **Part no. ZK07171**
- **Back draught safety device for Vitodens 99 kW**

Comprising a back draught safety device DN 110 with coding card. For vertical installation in the continuing flue pipe, directly downstream of the boiler. Must be added to the order for every boiler in the flue gas cascade: **Part no. ZK07172**

### 3.1 Product description

For details regarding DHW cylinders, see the technical guide to the Vitodens up to 35 kW, or separate datasheets.

## Design information

### 4.1 Siting, installation

#### Siting conditions for open flue operation (appliance type B)

(Type B<sub>23</sub> and B<sub>33</sub>)

In rooms where **air contamination from halogenated hydrocarbons or organosilicon compounds (e.g. siloxanes)** may occur, such as hairdressing salons, printing shops, dry cleaners, laboratories, etc., the Vitodens may only be operated as a **room sealed** system.

Wall mounted appliances should not be installed in areas subject to very dusty conditions.

The installation location must be kept free from frost and must be adequately ventilated.

Provide a condensate drain and a discharge pipe for the safety valve in the installation room.

The maximum ambient temperature of the system should not exceed 35 °C.

If these instructions are not observed any consequential appliance damage directly related to any of these causes is excluded from our warranty.

AT: When installing in Austria, observe all current safety regulations as defined by ÖVGW-TR Gas (G1), ÖNORM, ÖVGW, ÖVE and locally applicable standards.

#### Vitodens 200-W from 60 kW and multi boiler systems

In accordance with the German Combustion Order (FeuVo), boilers from 50 kW must be installed in a separate installation room [check local regulations]. The mains isolator must be fitted outside the installation room.

In accordance with the FeuVo [check local fire regulations], combustion equipment with a total rated output of more than 100 kW may only be installed and operated simultaneously in one room, if this room:

1. Is not used for purposes other than the installation of heat pumps, CHP units or permanently installed internal combustion engines, as well as for the associated installations and for storage of fuels,
2. Has no openings to other rooms, except for openings for doors,
3. Has self-closing doors that shut tightly, and
4. Can be ventilated.

However, combustion equipment for solid fuels may only be installed in one room if their total rated output does not exceed 50 kW.

#### Combustion air apertures

Gas equipment with a total rated heating output in excess of 50 kW must be provided with combustion air apertures leading to the outside. The cross-section must be at least 150 cm<sup>2</sup> and should be 2 cm<sup>2</sup> larger for each kW above 50 kW rated heating output. This cross-section may not be split over more than 2 apertures (observe FeuVo and TRGI 2018 point 5.5.4 [or local regulations]).

#### Example:

Vitodens 200-W, 3 × 60 kW

Total rated heating output 180 kW

150 cm<sup>2</sup> + 130 × 2 cm<sup>2</sup> = 410 cm<sup>2</sup> or 2 × 205 cm<sup>2</sup>.

The combustion air vents should measure at least 410 cm<sup>2</sup> or 2 × 205 cm<sup>2</sup>.

#### Multi boiler systems with flue systems under positive pressure

The Vitodens 200-W multi boiler systems with common flue systems under positive pressure are designed for **open** flue operation (type B).

For further details, see the technical guide on flue systems for the Vitodens.

#### Installation room (up to 50 kW)

##### Permissible:

- Siting gas equipment on the same floor
- Ancillary rooms with interconnected room air supply (larders, basements, utility rooms, etc.)
- Attic rooms, but only with adequate minimum chimney height, acc. to DIN 18160 – 4 m above inlet (negative pressure operation).

##### Not permissible:

- Stairwells and communal hallways; exception: Detached and two-family houses of low height (top edge of floor in the top storey < 7 m above ground level)
- Bathrooms and toilets without outside windows with shaft ventilation
- Rooms where explosive or flammable materials are stored
- Rooms that are ventilated mechanically or via individual duct systems to DIN 18117-1.

#### Observe all local fire regulations.

#### Connection on the flue gas side

The connection piece to the chimney should be as short as possible. Therefore position the Vitodens as close to the chimney as possible. The flue should be designed to be as straight as possible. If bends are unavoidable, do not arrange these directly one after another. It must be possible to test and clean the entire flue gas path as required.

No special protective measures or clearances towards combustible objects, such as furniture, packaging or similar, need to be taken/observed. The surface temperatures of the Vitodens and the flue system do not exceed 85 °C at any point.

For further details, see the technical guide on flue systems for the Vitodens.

#### Extractors

Operating appliances that extract air to the outside (extractor hoods, extractors, air conditioning units, etc.) can create negative pressure. If the boiler is operated at the same time, this can lead to a reverse flow of flue gas. This can cause life threatening poisoning.

To prevent the reverse flow of flue gas, fit an **interlock circuit** or take suitable steps to ensure an adequate supply of combustion air.

#### Safety equipment for the installation room

Viessmann heat generators are tested and approved in accordance with all safety regulations and are therefore fail-safe. Unpredictable, external factors may, in the rarest of cases, lead to the potentially harmful escape of carbon monoxide (CO). For this case, we recommend using a CO limiter. This can be ordered as a separate accessory.

### Siting conditions for room sealed operation (appliance type C)

The Vitodens can be installed as equipment type C<sub>13x</sub>, C<sub>33x</sub>, C<sub>53x</sub>, C<sub>63x</sub>, C<sub>83x</sub> or C<sub>93x</sub> to TRGI 2018 for **room sealed operation independently** of the size and ventilation of the installation room.

#### Installation room

It may, for example, be installed in recreation rooms, in other living spaces, in adjacent rooms without ventilation, in cupboards (open at the top) and recesses, without maintaining minimum clearances to combustible parts, as well as in attic rooms (pitched attics and long panes) where the balanced flue pipe can be routed directly through the roof.

Provide a condensate drain and a discharge pipe for the safety valve in the installation room.

Electrical interlocks for extractors (extractor hoods, etc.) are not required with room sealed operation.

#### Vitodens 200-W from 60 kW

In accordance with the German Combustion Order (FeuVo), boilers from 50 kW must be installed in a separate room [check local regulations]. The mains isolator must be fitted outside the installation room. Appropriate ventilation air and extract air apertures are required in accordance with TRGI (see the technical guide on flue systems for the Vitodens).

#### Connection on the flue gas side

The flue should be designed as short and straight as possible. If bends are unavoidable, do not install them directly one after another. It must be possible to test and clean the entire flue gas path as required.

Since the flue pipe connection for room sealed operation is surrounded by combustion air (coaxial pipe), maintaining clearances towards combustible components is not required.

Ventilation air shafts with which oil or solid fuel boilers were previously used must not contain any sulphur or soot deposits on the inner surfaces of the chimney. Sulphur and soot deposits cause operating faults. If thorough cleaning is not possible, a balanced flue pipe must be laid through the shaft. Alternatively, the flue gas/ventilation air pipes can be routed separately. Viessmann accepts no liability for damages resulting from failure to observe these instructions. For further details, see the technical guide on flue systems for the Vitodens.

#### Use of third party flue systems of type C<sub>63</sub>/C<sub>63x</sub>

Any approved flue system can be used for type C<sub>63</sub>/C<sub>63x</sub>. A system test of these flue systems with Viessmann heat generators has not been carried out, so there is no system certification in accordance with Gas Appliances Regulation (EU) 2016/426.

When implementing type C<sub>63</sub>/C<sub>63x</sub> with Viessmann heat generators, the following specifications must be observed and complied with:

- Viessmann design specifications for types C<sub>13x</sub>, C<sub>14(3)x</sub>, C<sub>33x</sub>, C<sub>53x</sub>, C<sub>83x</sub> and C<sub>93x</sub>
- Appliance-specific details of Viessmann heat generators, e.g. max. draughts, flue gas temperatures, mass flow rates, boiler flue connection tolerances
- Reverse flow of flue gas at the terminal of the flue system, even when it is windy: ≤ 10 %
- Wind protection devices for the supply of combustion air and the discharge of flue gas must not be installed on opposite walls of the building.

#### Flue pipes

- Flues made from plastic (PPS):  
Measures inside the equipment ensure that the flue gas temperature of 120 °C will never be exceeded. Flues made from plastic (PPS) with an approval for flue gas temperatures up to a maximum of 120 °C (type B) can therefore be used.
- Flues made from aluminium:  
Aluminium residues in the condensate can impair the function of the heat generator. A condensate trap must therefore be additionally installed above the boiler flue connection. The condensate trap must allow the condensate returned from the flue system to completely bypass the heat generator.

#### Dimensions of boiler flue gas connection

- Vitodens 200-W, 49 - 60 kW

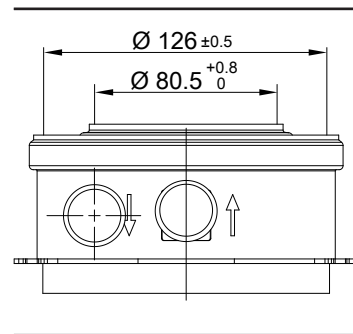

- Vitodens 200-W, 69 - 150 kW

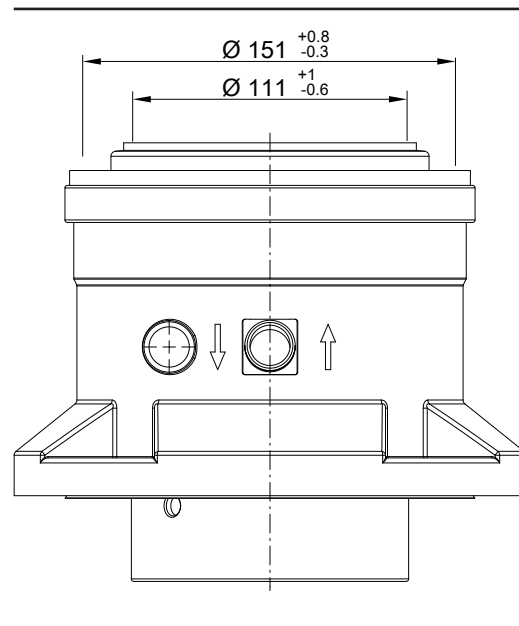

#### Modernisation projects with Vitodens and existing flue systems with pressure class "P"

- Today's advanced flue systems are approved for pressure class H1 according to DIN EN 1443 and consequently for operation at nominal pressures of up to 5000 Pa. By contrast, older flue systems installed in existing buildings are often certified to pressure class "P1" or "P2". These are only suitable for nominal pressures up to 200 Pa.
- If replacing a boiler, it is essential to clarify with the flue gas inspector in advance whether the previous flue systems will continue to be used.

## Design information (cont.)

- Flue gas gaskets are subject to wear; the tightness of the flue system cannot always be guaranteed in the long term. Since inspection or replacement of the gaskets already involves dismantling the flue system and cleaning the pipe sleeve and pipes, we recommend that the flue system is modernised.
- If reusing the previous flue system of pressure class P<sub>x</sub>, the nominal pressure in the flue system when operating with the new appliance under normal operating conditions must not exceed 200 Pa.
- Whether the existing flue system can continue to be used with the new appliance while observing the maximum pressure essentially depends on the cross-section and the length of the flue system and the rated output of the new appliance. Relevant data on the residual draughts of Vitodens appliances can be found in the respective flue gas technical guides or obtained directly from the technical guides for the respective boiler.
- The maximum flue gas side residual heads stated in the technical guides define the maximum flue gas pressure arising in the flue system in standard mode when combined with the indicated maximum flue pipe lengths and flue pipe cross-sections.
- Consequently, the maximum resulting flue gas pressure in standard mode can also be positively influenced by reducing the flue pipe lengths, enlarging the flue pipe cross-section and using an appliance with a low rated output.

The relevant data for Vitodens gas condensing boilers 1xx, 2xx and 3xx to 32 kW for compliance with a nominal pressure of 200 Pa can be found in the attached tables.

If the maximum flue pipe lengths listed in the tables are adhered to, a maximum flue system pressure of 200 Pa is maintained in standard mode.

### Single connection up to 150 kW

Product designation/type	Rated output (50/30 °C) in kW	Max. length of flue system 60/100	Max. length of flue system 80/125	Max. length of flue system 110/150
Vitodens 200-W type B2HA	49	—	12 m	17 m
	60	—	12 m	17 m
	80	—	—	20 m
	99	—	—	13 m
	120	—	—	09 m
	150	—	—	05 m

### Cascade installation up to 594 kW

Product designation/type	Rated output (50/30 °C) in kW	Max. length of flue system 160 mm	Max. length of flue system 200 mm	Max. length of flue system 250 mm
Vitodens 200-W type B2HA	2x 49/60	30	—	—
	2x 80/90	—	30	—
	3x 49/60	30	—	—
	3x 80/99	—	30	—
	4x 49/60	—	30	—
	4x 80/99	—	30	—
	5x 49/60	—	—	30
	5x 80/99	—	—	30
	6x 49/60	—	—	30
	6x 80/99	—	—	30

### Block arrangement

Vitodens 200-W type B2HA	4x 49/60	—	30	—
	4x 80/99	—	—	30
	6x 49/60	—	—	30
	6x 49/60	—	—	30

### Installation in a garage

Tests carried out by the Gaswärme-Institut e.V., Essen, have confirmed that the Vitodens is suitable for installation in garages. When installing this boiler in a garage, maintain a clearance between the floor and the burner of at least 500 mm. Install a frame or deflector (provided on site) to protect the boiler against mechanical damage.

### Safety equipment for the installation room

Viessmann heat generators are tested and approved in accordance with all safety regulations and are therefore fail-safe. Unpredictable, external factors may, in the rarest of cases, lead to the potentially harmful escape of carbon monoxide (CO). For this case, we recommend using a CO limiter. This can be ordered as a separate accessory.

## Operation of the Vitodens in wet rooms

- Room sealed operation:  
The Vitodens is approved for installation in wet rooms (IP rating: IP X4, splashproof).  
The boiler may be installed in safety zone 1 if hosed water (e.g. from massage showers) is prevented.
- Open flue operation:  
The Vitodens must not be installed in safety zone 1 or safety zone 2.

When installing the Vitodens in wet rooms, observe the safety zones and minimum wall clearances according to VDE 0100 [or local regulations] (see also "Electrical safety zone").



## Design information (cont.)

### Electrical safety zone

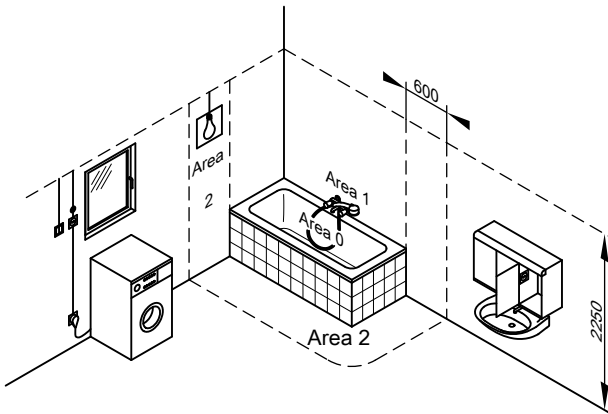

Electrical equipment in rooms containing a bathtub or a shower must be installed in such a way that users cannot be exposed to dangerous shock currents. VDE 0100 specifies that cables supplying permanently installed consumers in zones 1 and 2 should only be run vertically and routed into the equipment from the back.

### Electrical connection

The power supply must comply with the requirements of your local power supply utility and current VDE [or local] regulations (Ⓐ): ÖVE regulations!

Protect the power cable with a fuse with a max. rating of 16 A. We recommend installing an AC/DC-sensitive RCD (RCD class B) for DC (fault) currents that can occur with energy efficient equipment.

Make the power supply (230 V~, 50 Hz) via a permanent connection. Connect the supply cables and accessories at the terminals inside the boiler.

Allow cables/leads in the shaded area to protrude at least 800 mm from the wall (see diagram):

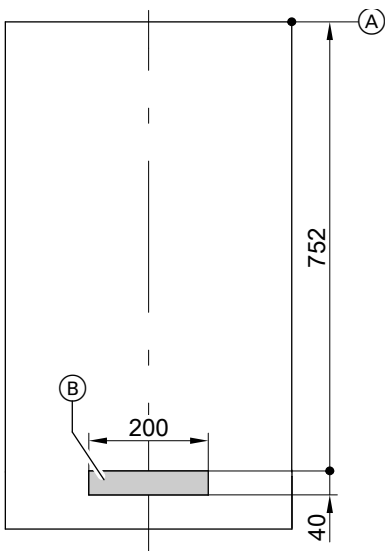

Vitodens 200-W, 49 to 99 kW

- Ⓐ Reference point Vitodens top edge
- Ⓑ Area for power cables

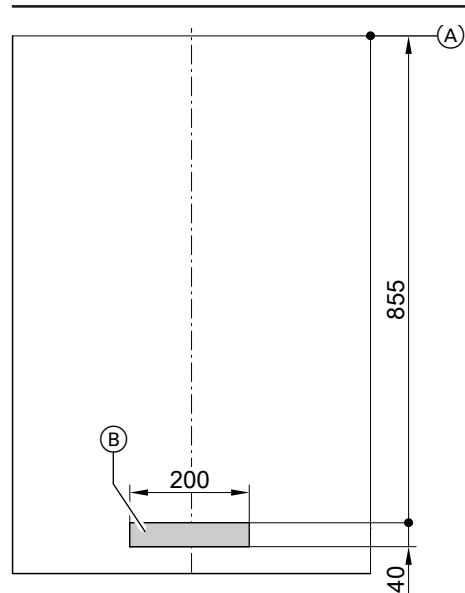

Vitodens 200-W, 120 to 150 kW

- Ⓐ Reference point Vitodens top edge
- Ⓑ Area for power cables

## Design information (cont.)

### Recommended cables

NYM 3 G 1.5 mm <sup>2</sup>	2-core min. 0.75 mm <sup>2</sup>	4-core 1.5 mm <sup>2</sup> or 3-core 1.5 mm <sup>2</sup> without green/yellow wire
<ul style="list-style-type: none"> <li>– Power cables (incl. accessories)</li> <li>– DHW circulation pump</li> </ul>	<ul style="list-style-type: none"> <li>– AM1 or EA1 extension</li> <li>– Outside temperature sensor</li> <li>– Vitotronic 200-H (LON)</li> <li>– Extension kit for heating circuit with mixer (KM-BUS)</li> <li>– Vitotrol 100, type UTDB</li> <li>– Vitotrol 200-A</li> <li>– Vitotrol 300-A</li> <li>– Wireless base station</li> <li>– Radio clock receiver</li> </ul>	<ul style="list-style-type: none"> <li>– Vitotrol 100, type UTDB-RF</li> <li>– Vitotrol 100, type UTA</li> </ul>

### Interlock switch

Install an interlock for open flue operation if an extractor (e.g. cooker hood) is fitted in any room forming part of the interconnected combustion air supply.

For this, the internal H2 extension (accessories) can be used. This switches any extractors off when the burner is started.

### Power supply for accessories

The power supply for accessories can be provided directly at the control unit.

This connection is switched by the system ON/OFF switch.

If the total system current exceeds 6 A, connect one or more extensions directly to the mains supply via an ON/OFF switch.

Where the boiler is sited in a wet room, the power supply connection of accessories must not be made at the control unit.

### Additional requirements when siting boilers operated with LPG in rooms below ground level

According to TRF 2012 – valid as of March 2012 – an external safety solenoid valve is no longer required when installing the Vitodens below ground level.

However, the high safety standard derived from the use of an external safety solenoid valve has proved to be valuable. We therefore recommend the continued installation of an external safety solenoid valve when installing the Vitodens in rooms below ground level. This requires the internal H1 extension.

### Gas connection

Gas installations must only be carried out by a registered gas fitter authorised by the relevant gas supply utility.

Connect and size the mains gas according to TRGI 2018 or TRF 2012 [or local regulations].

Ⓐ Connect the mains gas according to ÖVGW-TR Gas (G1) and the regionally applicable building regulations.

Max. test pressure 150 mbar (15 kPa).

We recommend installing a gas filter to DIN 3386 in the gas line.

### Thermally activated safety shut-off valve

According to paragraph 4, section 5 of the FeuVo 2008 [check local regulations], thermally actuated gas shut-off devices that shut off the gas supply if the external temperature exceeds 100 °C must be installed in combustion equipment or in gas lines immediately upstream of the combustion equipment. These valves must isolate the gas supply for at least 30 minutes up to a temperature of 650 °C. This is intended to prevent the formation of explosive gas mixtures in the event of a fire.

The gas shut-off valves supplied with the Vitodens are equipped with integral, thermally activated safety shut-off valves.

### Minimum clearances

Maintain a clearance of 700 mm in front of the Vitodens or the DHW cylinder for maintenance purposes.

No maintenance clearances are required to the left or right of the Vitodens.

### Wall mounting the Vitodens 200-W, 49 to 99 kW (single boiler)

The enclosed screws and rawl plugs are only suitable for concrete.

For other construction materials, use fixing materials that are suitable for 100 kg loads.

## Design information (cont.)

An installation template is supplied with the Vitodens 200-W to mark the position of the screws for the wall mounting bracket and the location of the flue pipe on the wall. Connection sets for connecting the heating circuits and a DHW cylinder must be ordered separately.

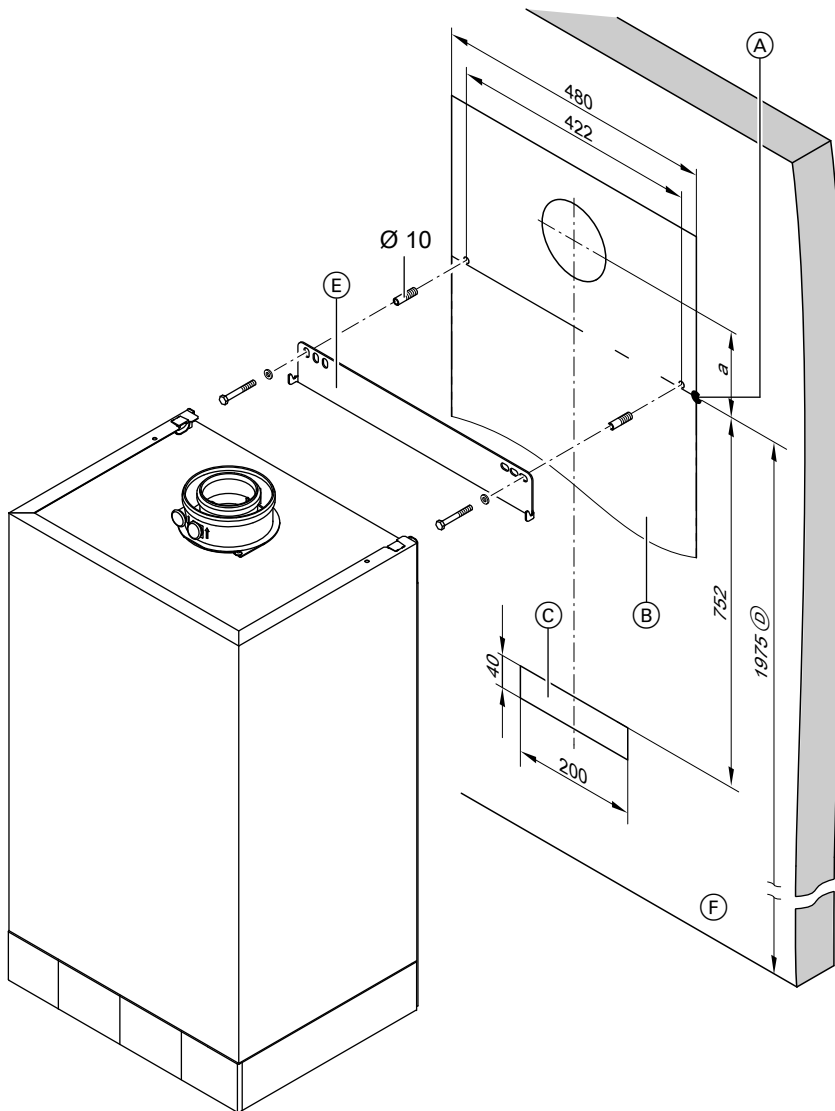

(A) Reference point Vitodens top edge

(B) Vitodens installation template

(C) Area for power cables

Allow cables to protrude approx. 1200 mm from the wall.

(D) Recommended dimension for single boiler system

(E) Wall mounting bracket

(F) Top edge of finished floor

Boiler		49 - 60 kW	80 - 99 kW
a	mm	138	268

### Plumbing wall installation with a plumbing wall mounting frame (single boiler)

The Vitodens can be mounted on the plumbing wall mounting frame. The mounting bracket supplied with the boiler cannot then be used.

## Design information (cont.)

### Dimensions, heating circuit connection set with low loss header and connection accessories

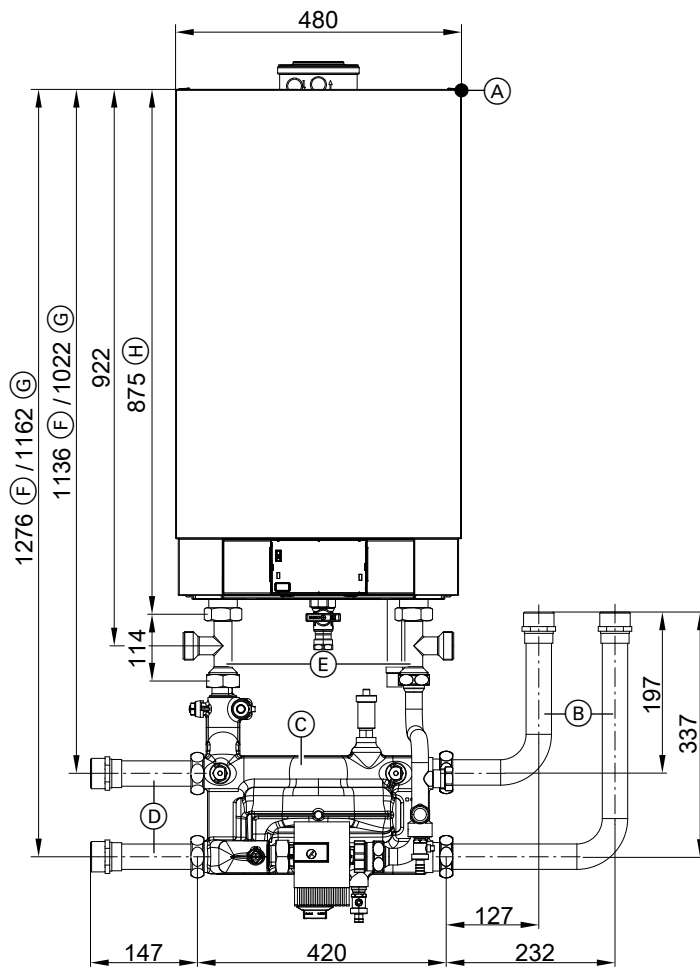

- (A) Top edge reference point, Vitodens (also see previous drawing)
- (B) Connection accessories for installation to the top/bottom
- (C) Heating circuit connection set with low loss header
- (D) Connection accessories for installation to the left/right
- (E) DHW cylinder connection set
- (F) Dimensions **with** DHW cylinder connection set
- (G) Dimensions **without** DHW cylinder connection set
- (H) Dimension without connection accessories

#### Note

- The various connection accessories can be installed either to the right or to the left. It is not possible to install them on both sides!
- The pipe bends can also be turned downwards.

### Wall mounting the Vitodens 200-W, 120 to 150 kW (single boiler)

The enclosed screws and rawl plugs are only suitable for concrete. For other construction materials, use fixing materials that are suitable for 145 kg loads.

The mounting frame (accessories) is recommended for installing the Vitodens (see page 62).

## Design information (cont.)

Connection sets for connecting the heating circuits and a DHW cylinder must be ordered separately.

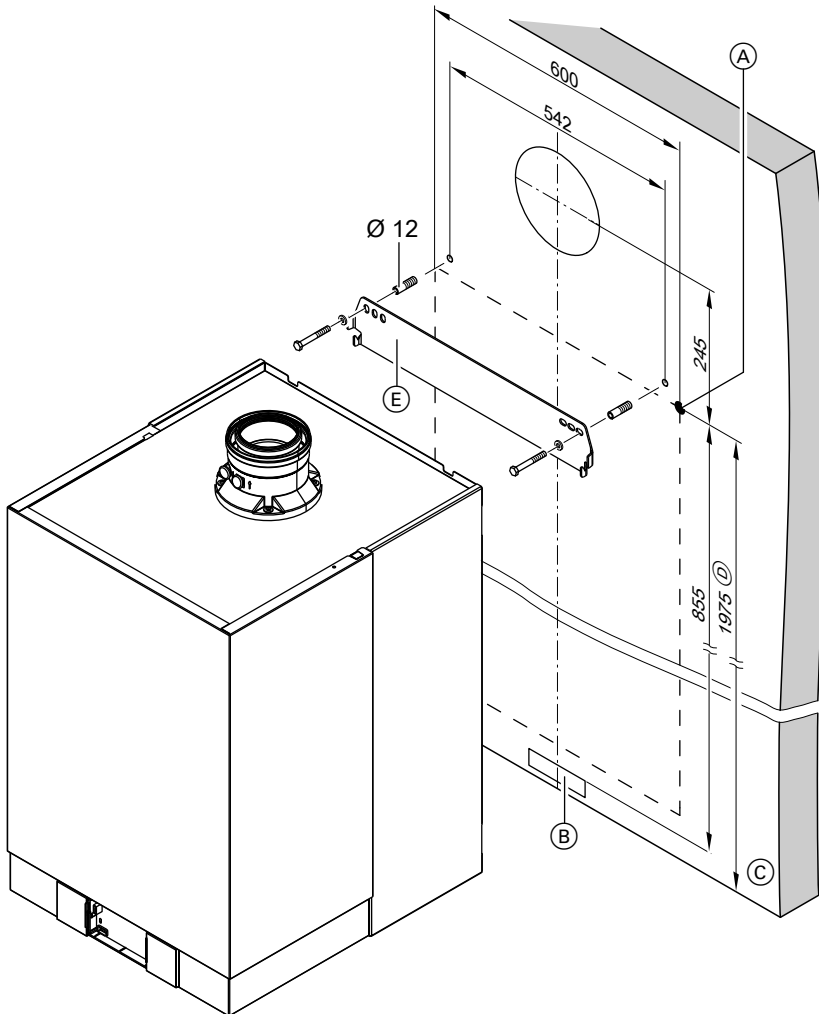

(A) Reference point Vitodens top edge

(B) Area for power cables.

Allow cables to protrude approx. 1200 mm from the wall.

(C) Top edge of finished floor

(D) Recommended dimension for single boiler system

(E) Wall mounting bracket

## Design information (cont.)

### Dimensions, heating circuit connection set with low loss header and connection accessories

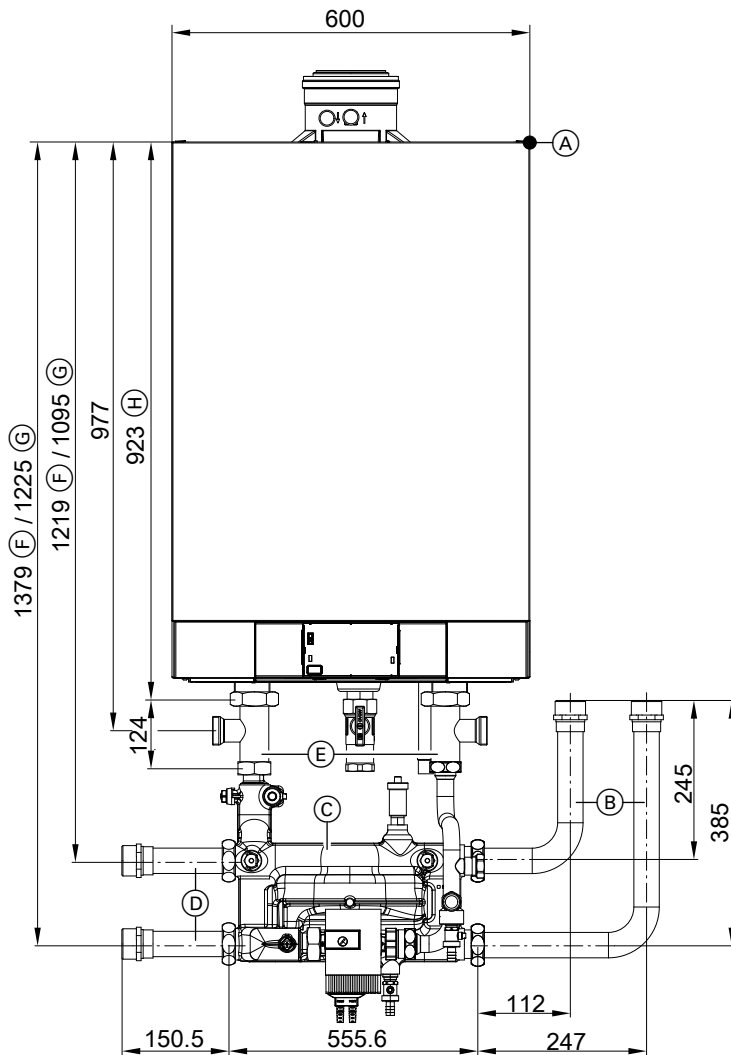

- (A) Top edge reference point, Vitodens (also see previous drawing)
- (B) Connection accessories for installation to the top/bottom
- (C) Heating circuit connection set with low loss header
- (D) Connection accessories for installation to the left/right

- (E) DHW cylinder connection set
- (F) Dimensions **with** DHW cylinder connection set
- (G) Dimensions **without** DHW cylinder connection set
- (H) Dimension without connection accessories

#### Note

- The various connection accessories can be installed either to the right or to the left. It is not possible to install them on both sides!
- The pipe bends can also be turned downwards.

### Installation with mounting frame, Vitodens 200-W, 49 to 150 kW (single boiler)

The Vitodens can be installed freestanding in the room by using the mounting frame available as an accessory.

- The Vitodens can be fastened to the mounting frame at a choice of two heights (A).
- The boiler can be levelled by means of adjustable feet.

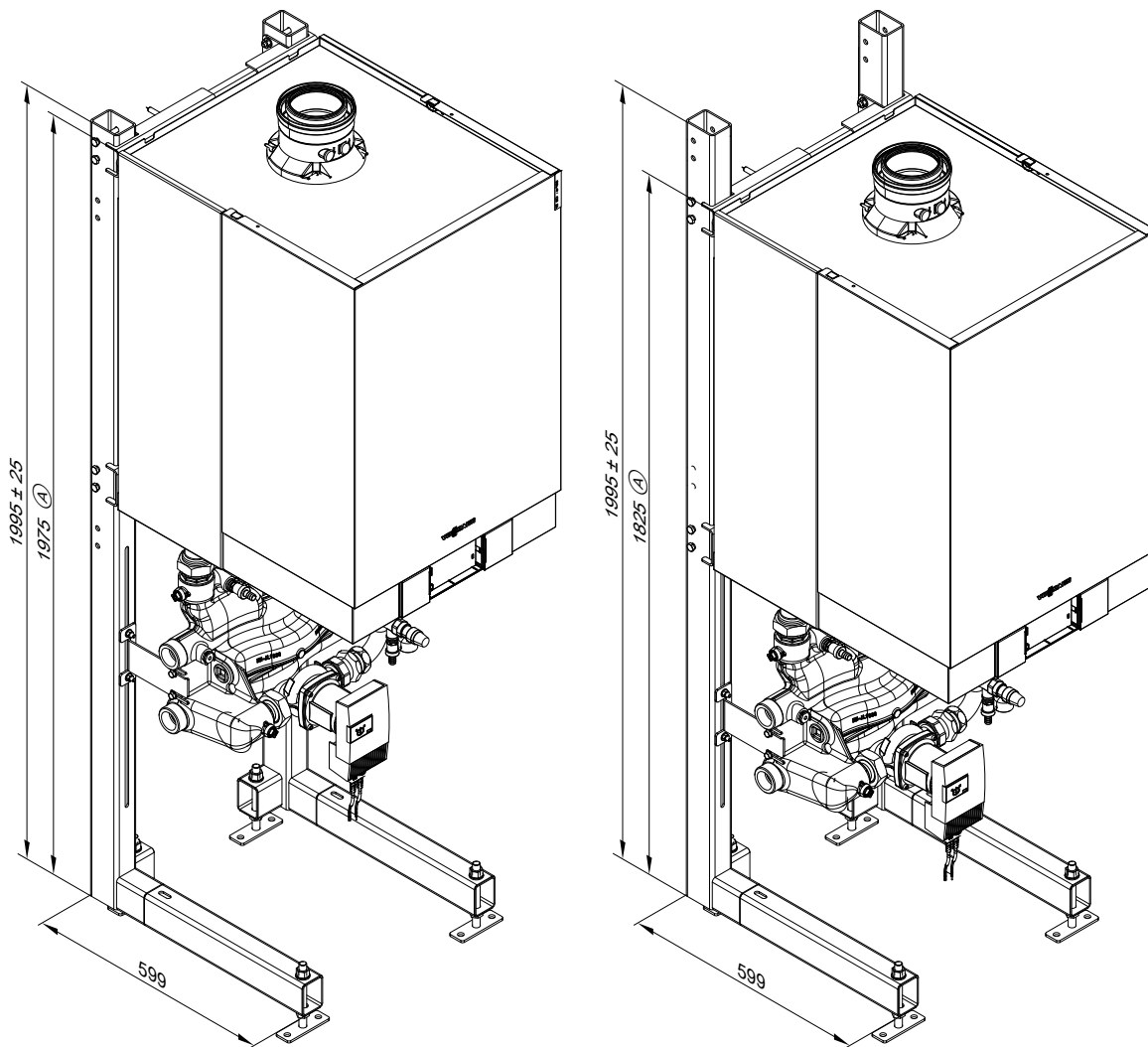

## Multi boiler system

### Hydraulic cascade

Flow and return manifold for multi boiler systems with:

- 2 to 6 boilers mounted on a wall
- 2 to 6 boilers in inline formation
- 4 or 6 boilers installed in block formation

Optionally with a low loss header or cascade module adaptor for connecting the heating circuits. Must be ordered separately as an accessory.

Heating circuit connections can be either on the right or left.

## Design information (cont.)

### Specification

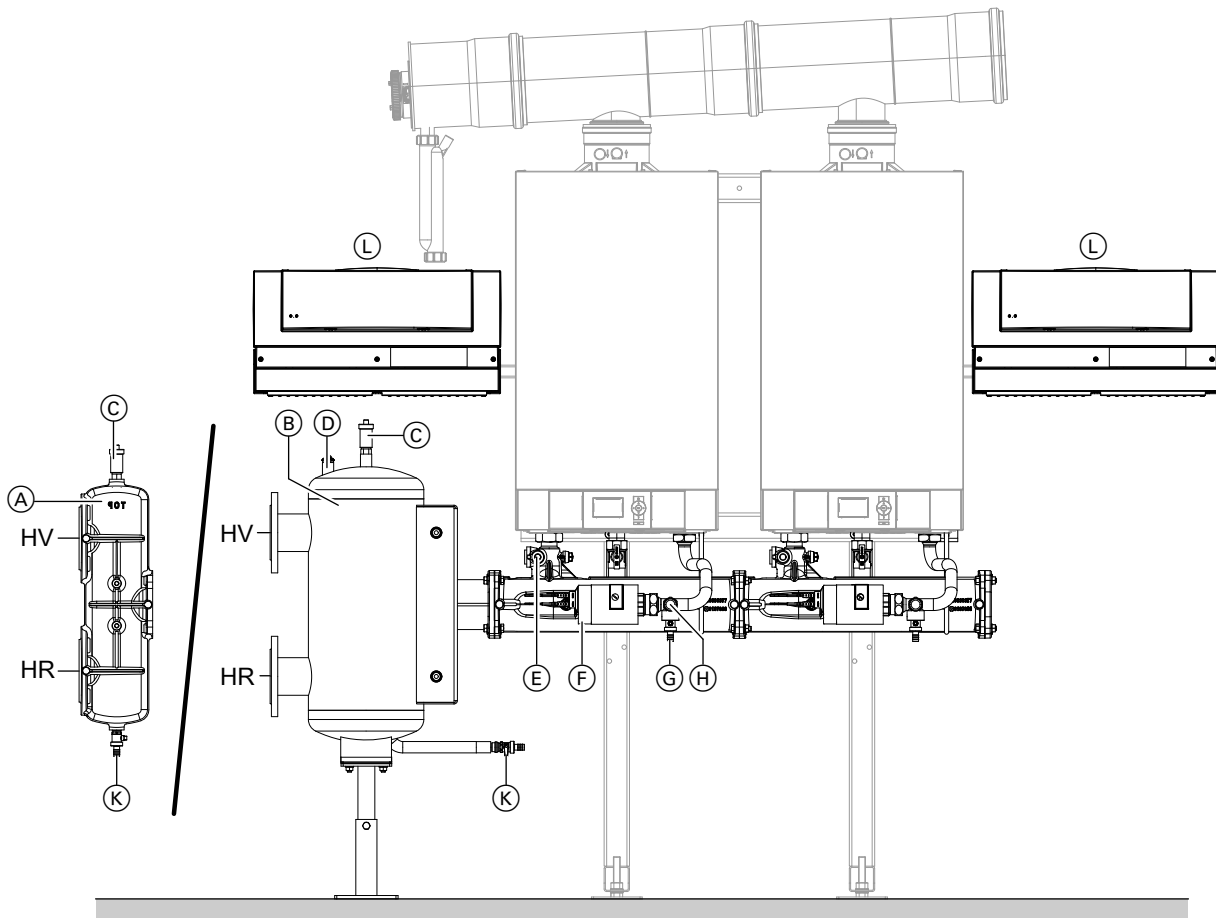

Shown without the thermal insulation supplied

- |   |  |
|---|--|
| (A) Cascade module adaptor                  | (H) Safety valve   |
| (B) Low loss header                         | (K) Drain  |
| (C) Air vent valve                          | (L) Vitotronic 300-K (can be fitted either to the left or the right) |
| (D) Sensor well for flow temperature sensor | The total length of all BUS cables (on site) should not exceed 50 m. |
| (E) Boiler drain & fill valve               | HR Heating water return  |
| (F) High efficiency circulation pump        | HV Heating water flow  |
| (G) Boiler drain & fill valve               |  |

Number of boilers		2	3	4/2 x 2	5	6/2 x 3
<b>Heating circuit connection</b>						
- Low loss header	PN6/DN	80	80	80	80	80
- Cascade module adaptor	PN6/DN	100	100	100	100	100
<b>Boiler connection</b>		G	1½	1½	1½	1½
<b>Max. flow rate</b>		<b>Δt</b>				
- 49 kW	15 K	m <sup>3</sup> /h	5.6	8.4	11.2	14.0
- 60 kW	15 K	m <sup>3</sup> /h	6.9	10.3	13.8	17.2
- 69 kW	20 K	m <sup>3</sup> /h	5.9	8.9	11.8	14.8
- 80 kW	20 K	m <sup>3</sup> /h	6.9	10.3	13.7	17.2
- 99 kW	20 K	m <sup>3</sup> /h	8.5	12.8	17.0	21.3
<b>Circulation pump</b>		Type	VI Para MAXO 25-130/11			
Rated voltage		V~	230			
Max. power consumption		W	140			
Min. power consumption		W	8			



## Design information (cont.)

### Residual head of the integral circulation pump at 49 - 60 kW

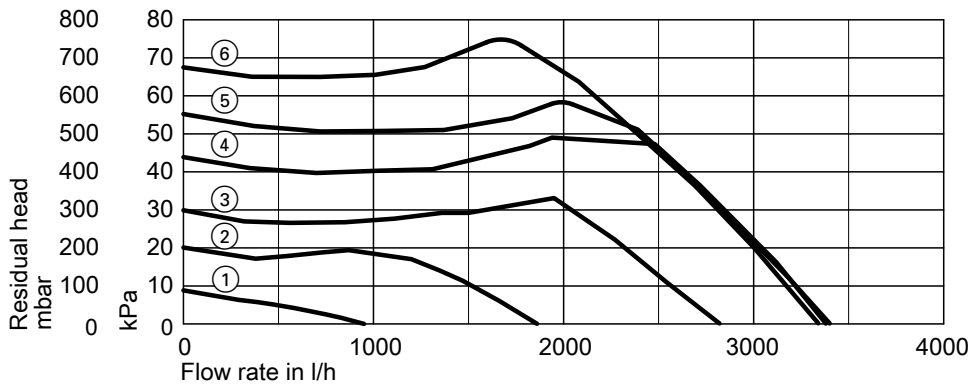

① to ⑥ Pump stage setting

### Residual head of the integral circulation pump at 69 - 99 kW

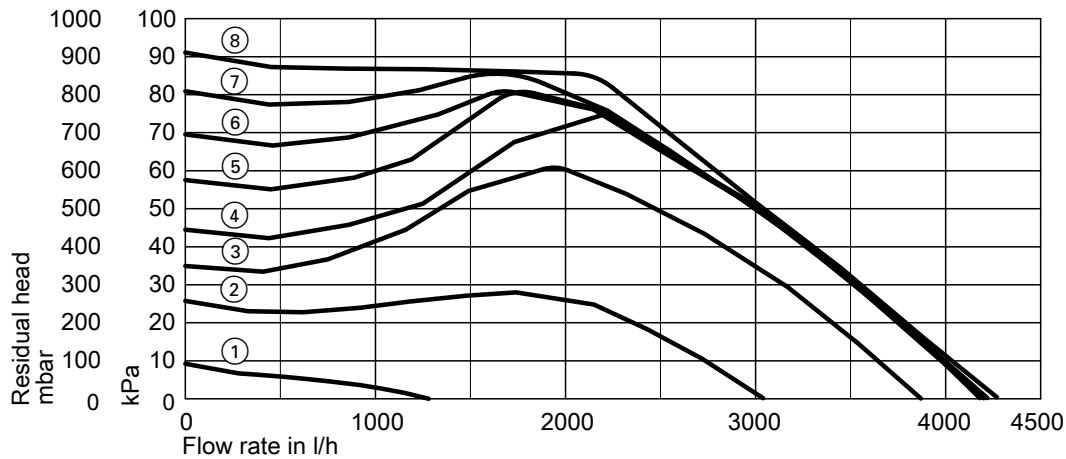

① to ⑧ Pump stage setting

#### Multi boiler system standard delivery

- Vitodens 200-W (2 to 6 boilers)
- Vitotronic 300-K cascade control unit
- Cascade communication module for each boiler
- Immersion temperature sensor
- Mounting frame or pre-plumbing jig for wall mounting
- Hydraulic cascade with high efficiency circulation pump and thermal insulation

#### Accessories (subject to order)

- Flue gas cascade
- Low loss header with connection lines and thermal insulation or
- Cascade module adaptor with thermal insulation
- Pipe bends for corner installation with thermal insulation

## Design information (cont.)

### Wall mounting with low loss header

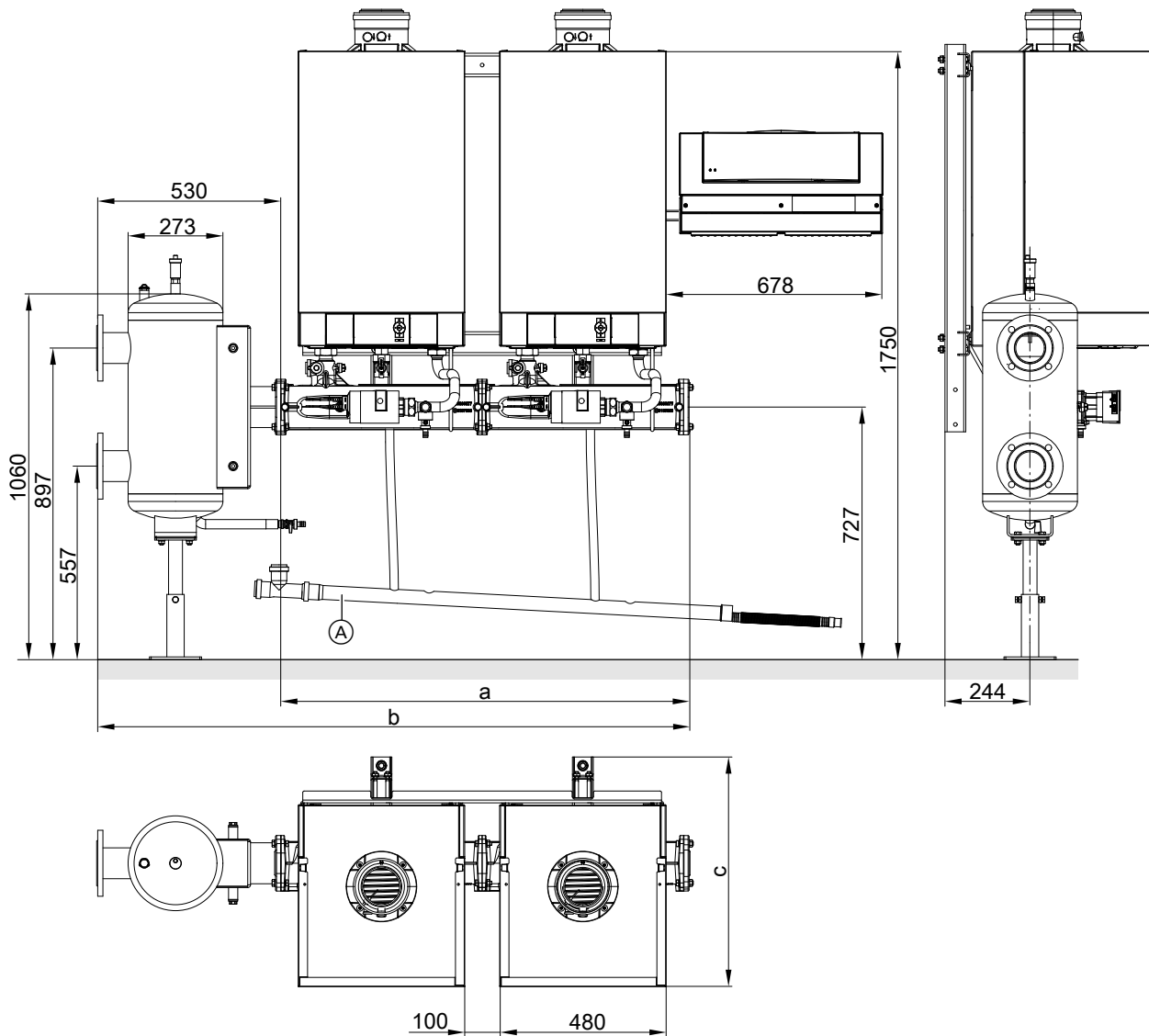

Shown without the thermal insulation supplied

(A) Condensate collector (accessories)

Number of boilers	Rated heating output	kW	2		3		4		5		6	
			49 - 60	69 - 99	49 - 60	69 - 99	49 - 60	69 - 99	49 - 60	69 - 99	49 - 60	69 - 99
a	mm		1190	1190	1770	1770	2350	2350	2930	2930	3510	3510
b	mm		1720	1720	2300	2300	2880	2880	3460	3460	4040	4040
c	mm		511	661	511	661	511	661	511	661	511	661

#### Note

The height dimensions can be reduced by max. 150 mm. In this case, the fixing profiles must be installed accordingly.

## Design information (cont.)

### Wall mounting with a cascade module adaptor

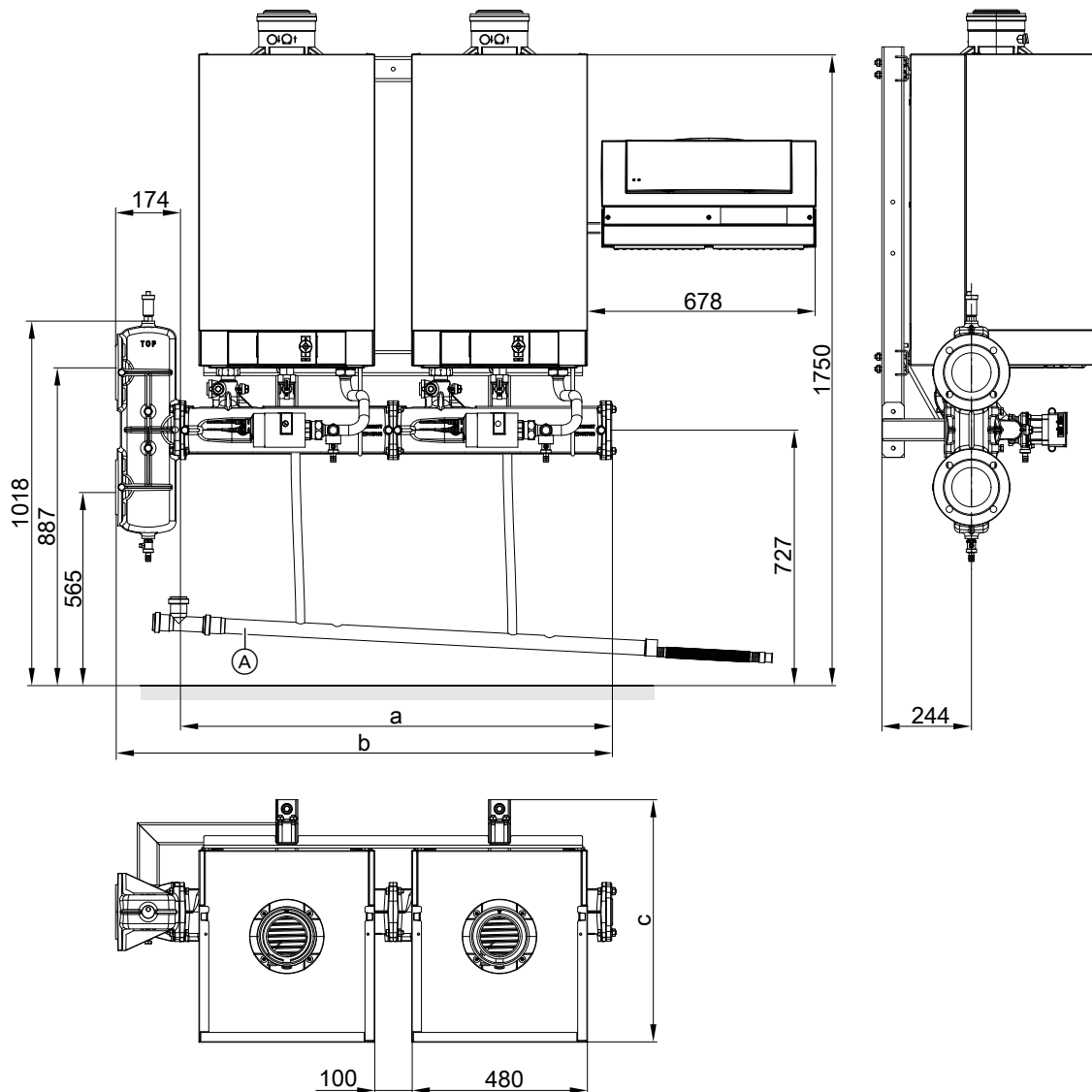

Shown without the thermal insulation supplied

(A) Condensate collector (accessories)

Number of boilers	Rated heating output	kW	2		3		4		5		6	
			49 - 60	69 - 99	49 - 60	69 - 99	49 - 60	69 - 99	49 - 60	69 - 99	49 - 60	69 - 99
a	mm		1190	1190	1770	1770	2350	2350	2930	2930	3510	3510
b	mm		1364	1364	1944	1944	2524	2524	3104	3104	3684	3684
c	mm		511	661	511	661	511	661	511	661	511	661

#### Note

The height dimensions can be reduced by max. 300 mm. In this case, the fixing profiles must be installed accordingly.

## Design information (cont.)

### Freestanding installation in inline and block formation with a mounting frame

#### In inline formation with a low loss header

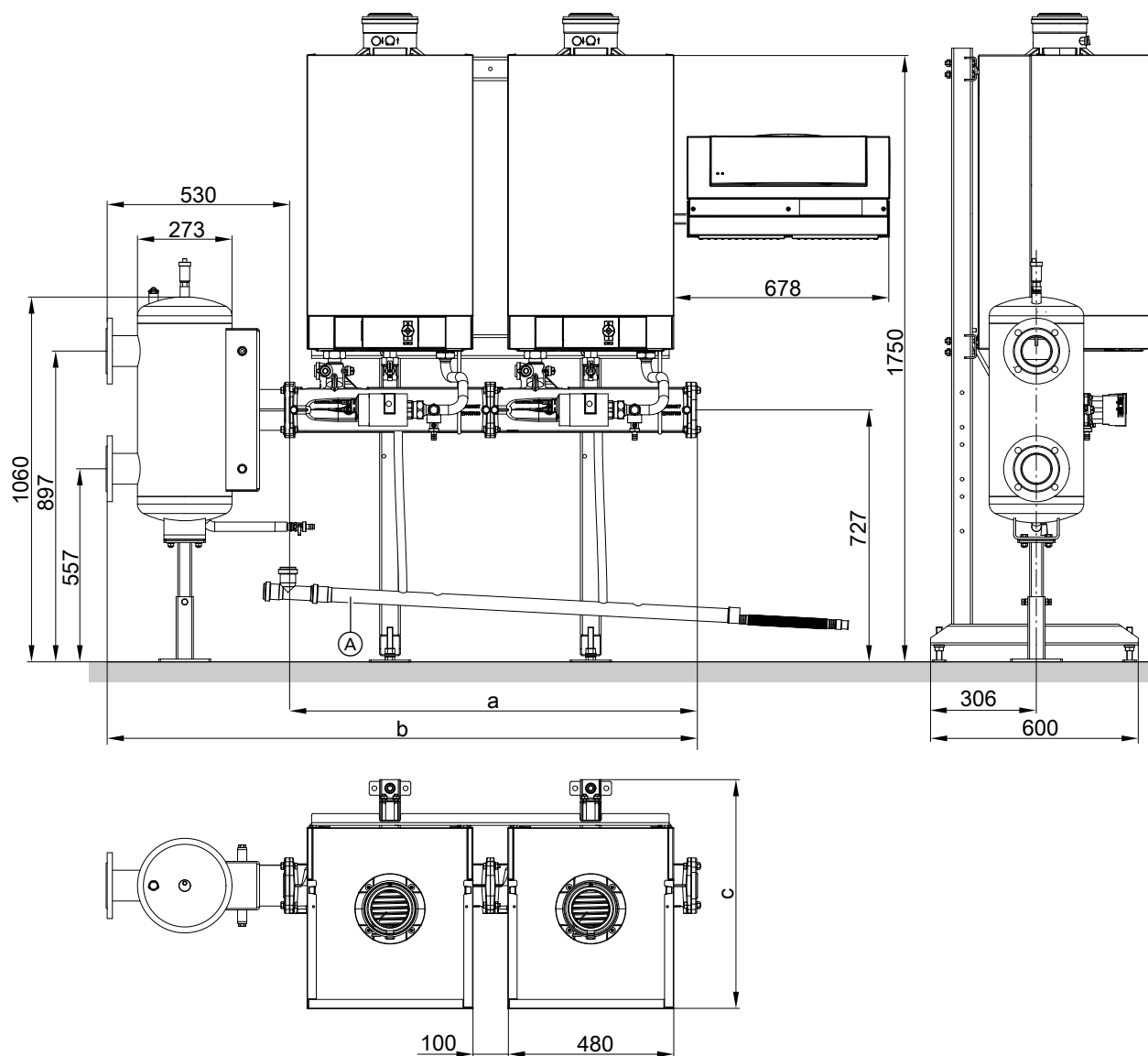

Shown without the thermal insulation supplied

(A) Condensate collector (accessories)

Number of boilers	Rated heating output	kW	2		3		4		5		6	
			49 - 60	69 - 99	49 - 60	69 - 99	49 - 60	69 - 99	49 - 60	69 - 99	49 - 60	69 - 99
a	mm		1190	1190	1770	1770	2350	2350	2930	2930	3510	3510
b	mm		1720	1720	2300	2300	2880	2880	3460	3460	4040	4040
c	mm		511	661	511	661	511	661	511	661	511	661

#### Note

The height dimensions can be reduced by 150 mm if using a mounting frame for installation. In this case, the fixing profiles must be installed accordingly.

## Design information (cont.)

### Installation in block formation with a low loss header

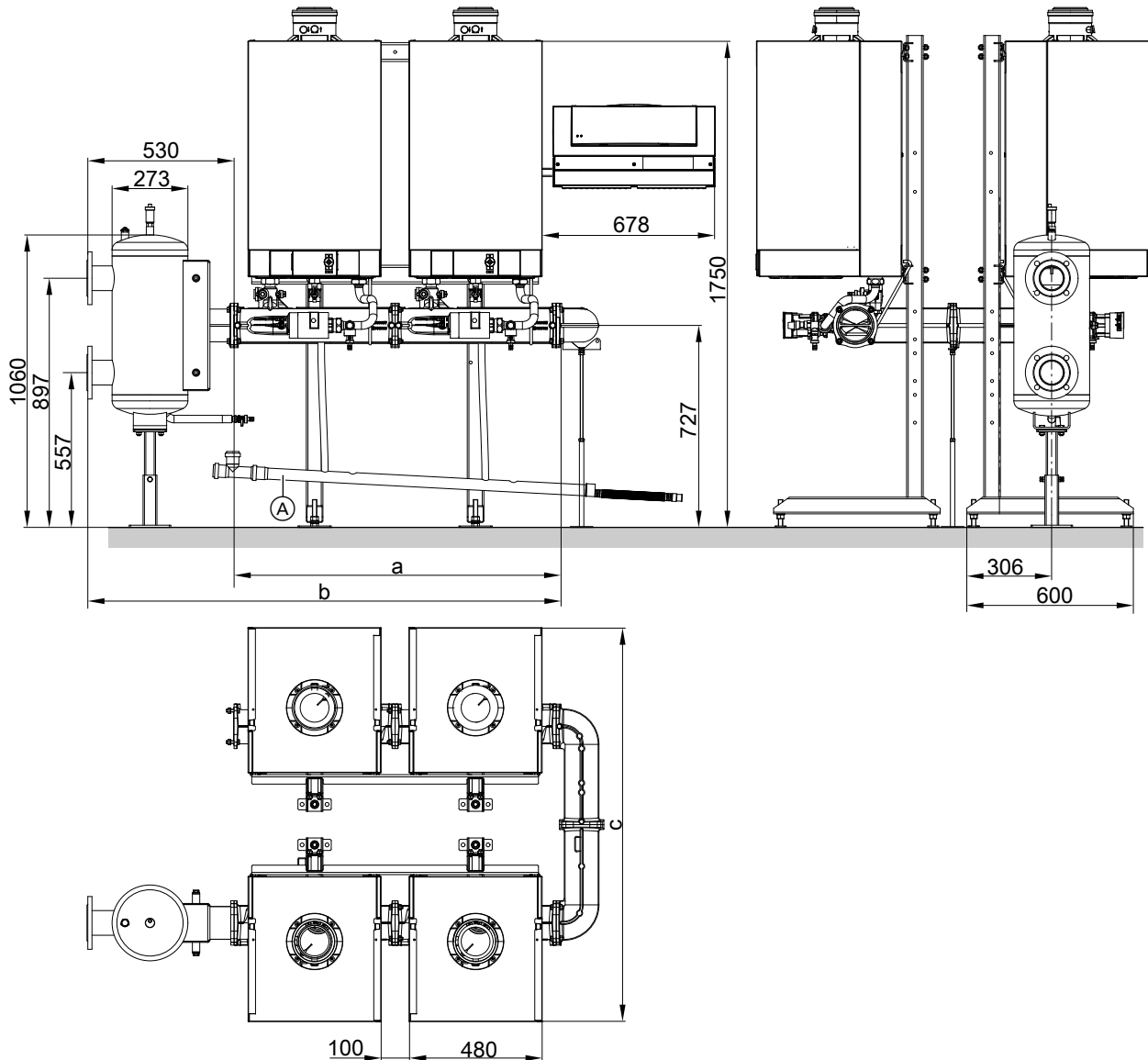

Shown without the thermal insulation supplied

(A) Condensate collector (accessories)

Number of boilers		2 x 2 49 - 60 kW	2 x 2 69 - 99 kW	2 x 3 49 - 60 kW	2 x 3 69 - 99 kW
a	mm	1190	1190	1770	1770
b	mm	1720	1720	2300	2300
c	mm	1350	1422	1350	1422

#### Note

The height dimensions can be reduced by 150 mm if using a mounting frame for installation. In this case, the fixing profiles must be installed accordingly.

## Design information (cont.)

In inline formation with a cascade module adaptor

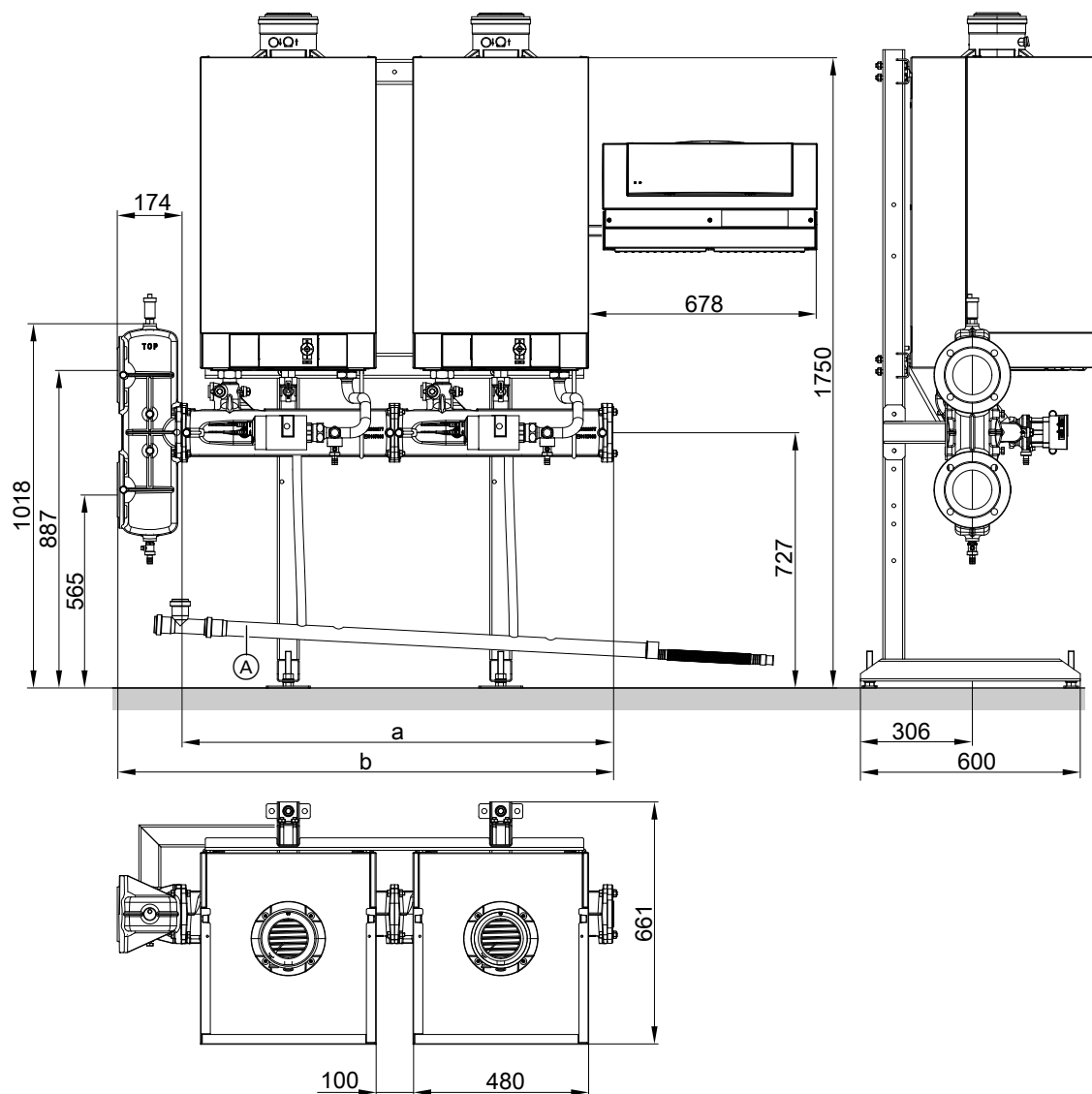

Shown without the thermal insulation supplied

(A) Condensate collector (accessories)

Number of boilers	Rated heating output	kW	2		3		4		5		6	
			49 - 60	69 - 99	49 - 60	69 - 99	49 - 60	69 - 99	49 - 60	69 - 99	49 - 60	69 - 99
a	mm		1190	1190	1770	1770	2350	2350	2930	2930	3510	3510
b	mm		1364	1364	1944	1944	2524	2524	3104	3104	3684	3684
c	mm		511	661	511	661	511	661	511	661	511	661

### Note

The height dimensions can be reduced by 150 or 300 mm if using a mounting frame for installation. In this case, the fixing profiles must be installed accordingly.

## Design information (cont.)

### Installation in block formation with a cascade module adaptor

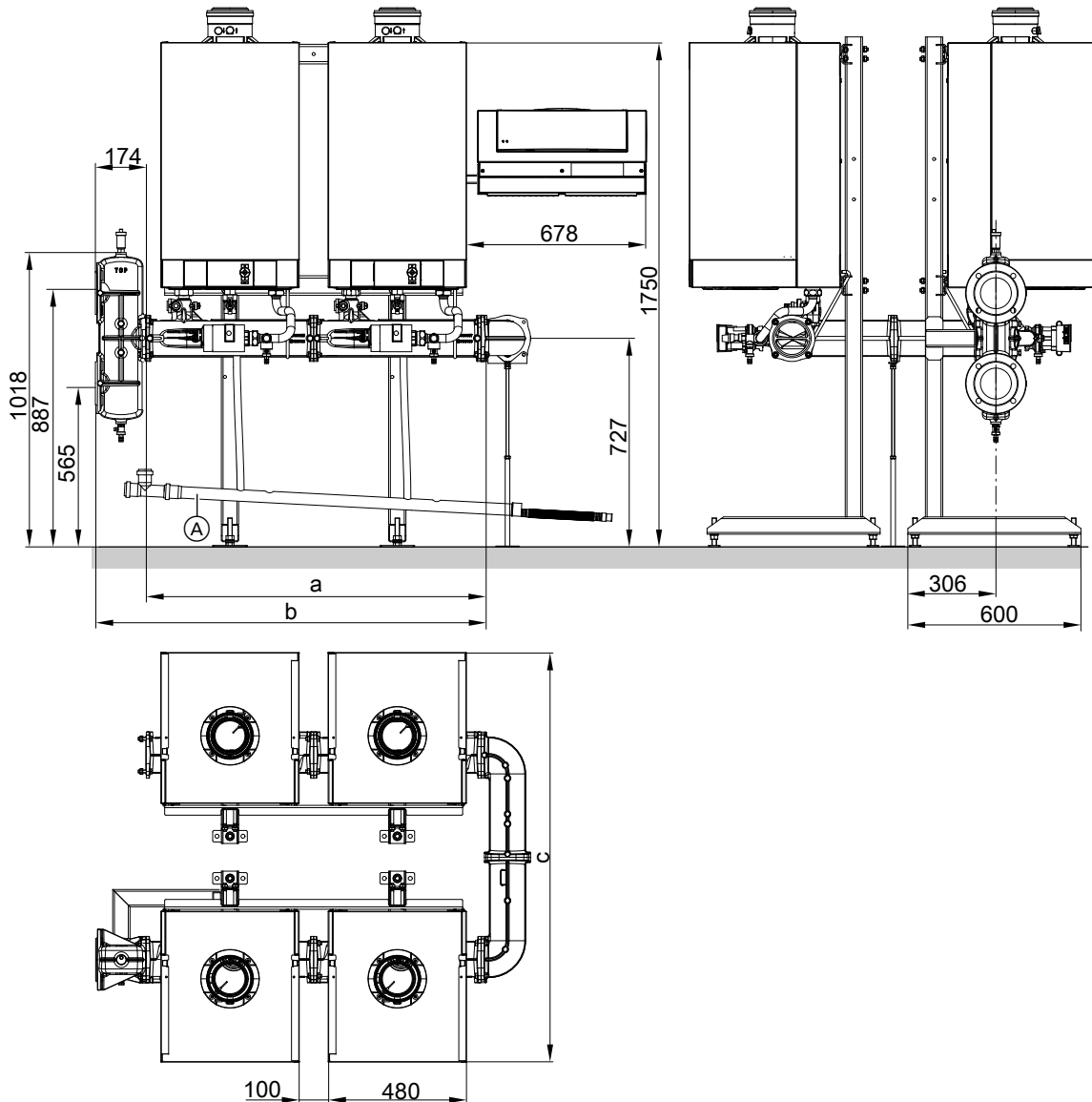

Shown without the thermal insulation supplied

(A) Condensate collector (accessories)

Number of boilers		2 x 2 49 - 60 kW	2 x 2 69 - 99 kW	2 x 3 49 - 60 kW	2 x 3 69 - 99 kW
a	mm	1190	1190	1770	1770
b	mm	1364	1364	1944	1944
c	mm	1350	1422	1350	1422

#### Note

The height dimensions can be reduced by 150 or 300 mm if using a mounting frame for installation. In this case, the fixing profiles must be installed accordingly.

## Design information (cont.)

### Corner installation, multi boiler system

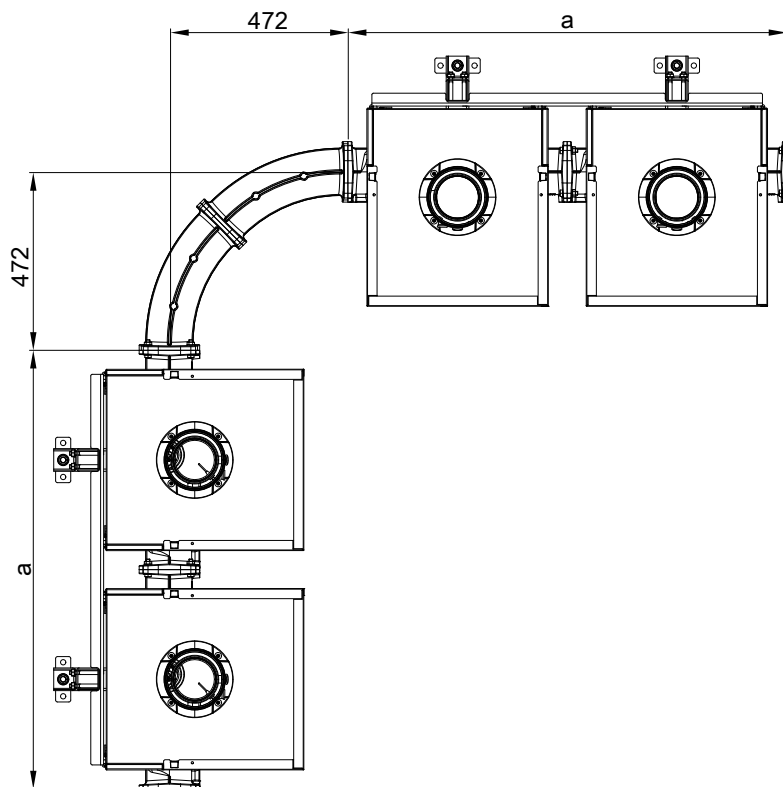

Number of boilers	2 x 49 - 99 kW	3 x 49 - 99 kW	4 x 49 - 99 kW	5 x 49 - 99 kW	6 x 49 - 99 kW
a mm	1160	1740	2320	2900	3480

### Corner installation, low loss header in a multi boiler system

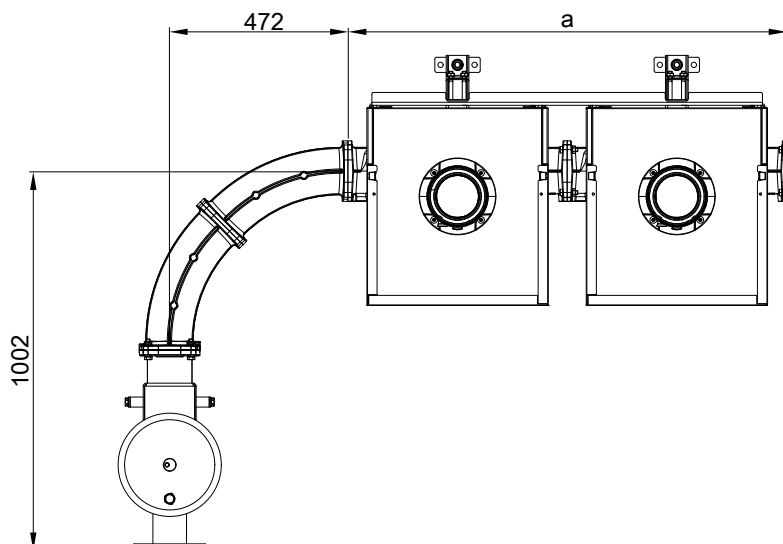

Number of boilers	2 x 49 - 99 kW	3 x 49 - 99 kW	4 x 49 - 99 kW	5 x 49 - 99 kW	6 x 49 - 99 kW
a mm	1160	1740	2320	2900	3480



## Design information (cont.)

Corner installation, cascade module adaptor in a multi boiler system

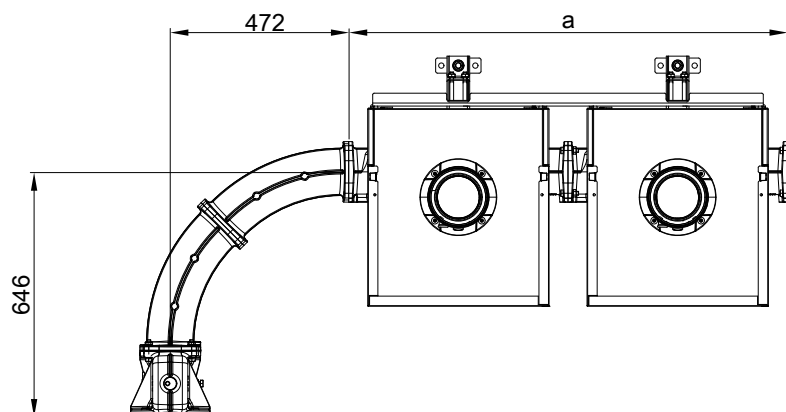

Number of boilers	2 x 49 - 99 kW	3 x 49 - 99 kW	4 x 49 - 99 kW	5 x 49 - 99 kW	6 x 49 - 99 kW
a mm	1160	1740	2320	2900	3480

## Design information (cont.)

### Flue gas cascade

### Inline formation

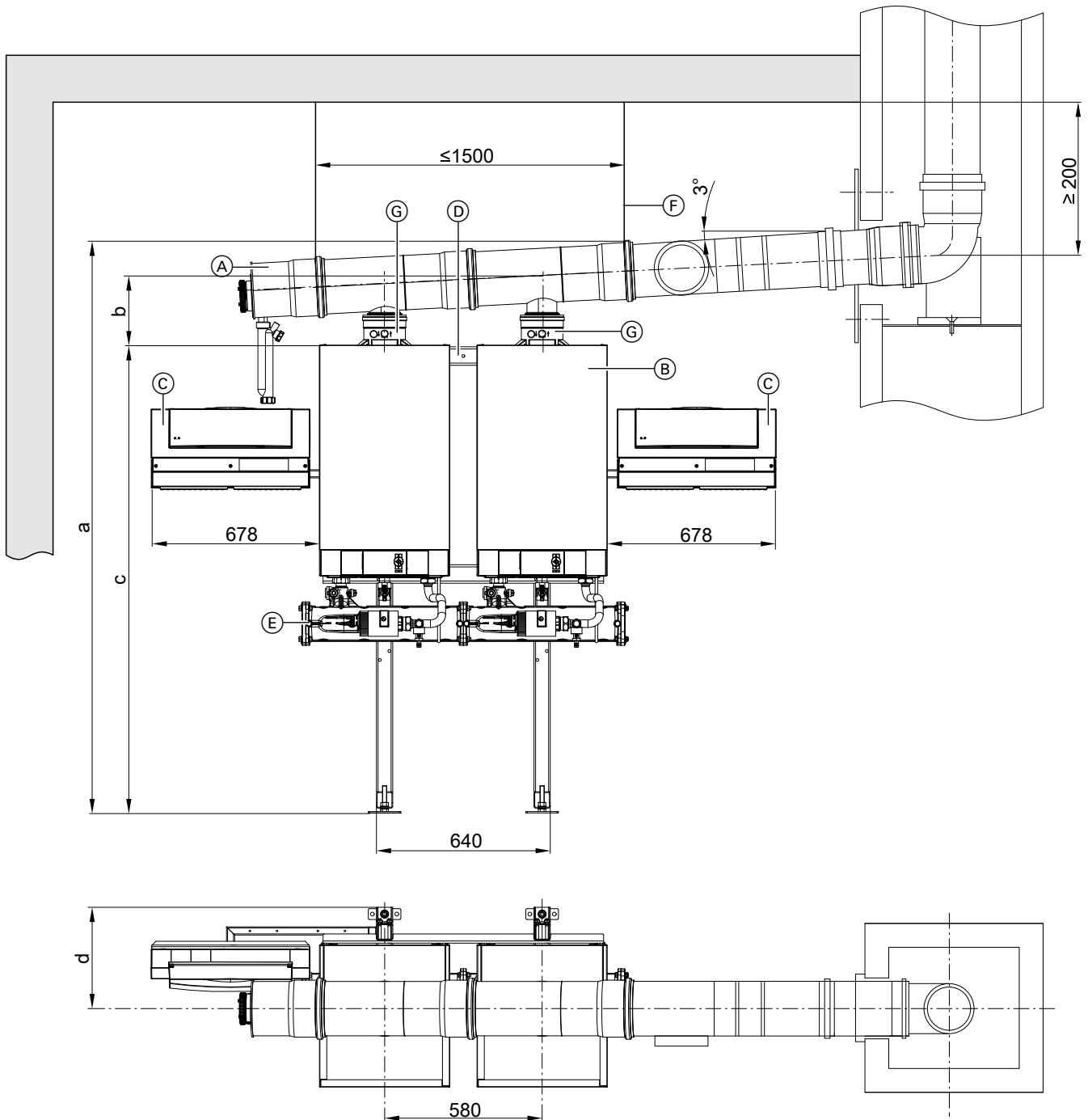

Shown without the thermal insulation supplied

- |  |   |
|--|---|
| (A) Flue gas cascade   | (D) Mounting frame or pre-plumbing jig        |
| (B) Vitodens   | (E) Hydraulic cascade                         |
| (C) Vitotronic 300-K (can be fitted either to the left or the right) | (F) Ceiling fixing point for flue gas cascade |
|  | (G) Back draught safety device                |

#### Note

Secure the flue gas cascade with suitable means. Suspension from the ceiling is recommended. Observe the max. distance between fixing points (F).

For details regarding the flue gas cascade, see page 53 and the technical guide on flue systems. A flue gas back draught safety device is integrated into each boiler. For further details regarding the hydraulic cascade, see page 63.

## Design information (cont.)

### Note

A second flue gas back draught safety device must be added to the order for every boiler and installed directly downstream of the boiler flue connection in the continuing flue pipe (vertical)!

Number of boilers		2x49 kW 2x60 kW	2x80 kW 2x99 kW	3x49 kW 3x60 kW	3x80 kW 3x99 kW	4x49 kW 4x60 kW	4x80 kW 4x99 kW	5x49 kW 5x60 kW	5x80 kW 5x99 kW	6x49 kW 6x60 kW	6x80 kW 6x99 kW
a	mm	2111	2136	2141	2166	2196	2196	2251	2251	2281	2281
b	mm	231	256	261	286	316	316	371	371	401	401
c	mm	1750	1750	1750	1750	1750	1750	1750	1750	1750	1750
d	mm	291	373	291	373	291	373	291	373	291	373

### Note

Height dimension "c" can be reduced by 150 mm in conjunction with a low loss header and by 300 mm in conjunction with a cascade module adaptor. In this case, the fixing profiles must be installed accordingly. For installation directly onto a wall, these dimensions should also be adhered to.

## Design information (cont.)

### Block arrangement

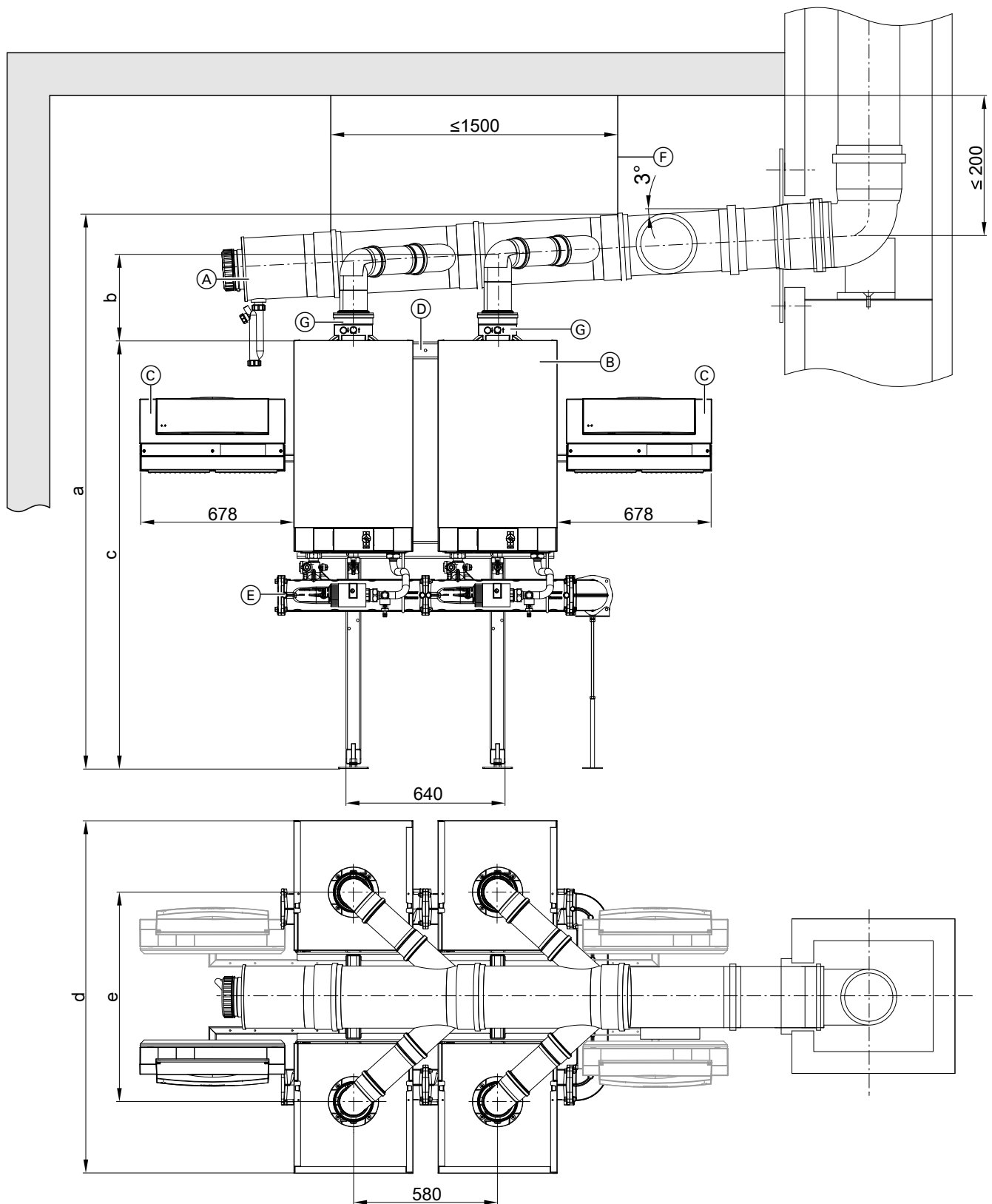

Shown without the thermal insulation supplied

- (A) Flue gas cascade
- (B) Vitodens
- (C) Vitotronic 300-K (can be fitted either to the left or the right)
- (D) Mounting frame or pre-plumbing jig
- (E) Hydraulic cascade



## Design information (cont.)

- Ⓕ Ceiling fixing point for flue gas cascade
- Ⓖ Back draught safety device

### Note

Secure the flue gas cascade with suitable means.  
Suspension from the ceiling is recommended. Observe the max. distance between fixing points Ⓕ.

For details regarding the flue gas cascade, see page 53 and the technical guide on flue systems. A flue gas back draught safety device is integrated into each boiler.

For further details regarding the hydraulic cascade, see page 63.

### Note

A second flue gas back draught safety device must be added to the order for every boiler and installed directly downstream of the boiler flue connection in the continuing flue pipe (vertical)!

Boiler		(2x2) 49 kW (2x2) 60 kW	(2x2) 80 kW (2x2) 99 kW	(2x3) 49 kW (2x3) 60 kW	(2x3) 80 kW (2x3) 99 kW
a	mm	2111	2136	2141	2166
b	mm	176	207	176	207
c	mm	1750	1750	1750	1750
d	mm	1350	1422	1350	1422
e	mm	680	843	680	843

### Note

Height dimension "c" can be reduced by 150 mm in conjunction with a low loss header and by 300 mm in conjunction with a cascade module adaptor. In this case, the fixing profiles must be installed accordingly.

## 4.2 Condensate connection

Route the condensate pipe with a constant fall.

Route the condensate from the flue system (if equipped with a drain) together with the boiler condensate directly or (if required) via a neutralising system (accessories) to the waste water system.

### Note

A pipe vent **must** be installed between the trap and the neutralising system.

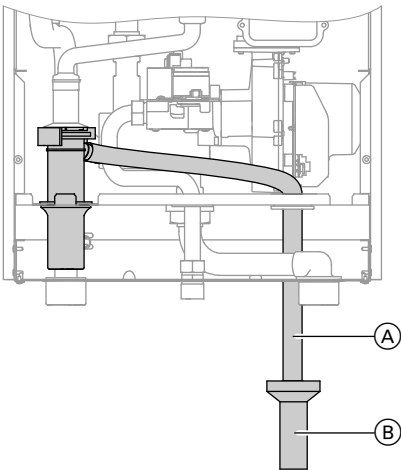

Vitodens 200-W, 49 and 60 kW

- Ⓐ Drain hose (Vitodens standard delivery)
- Ⓑ Drain outlet kit (accessories)

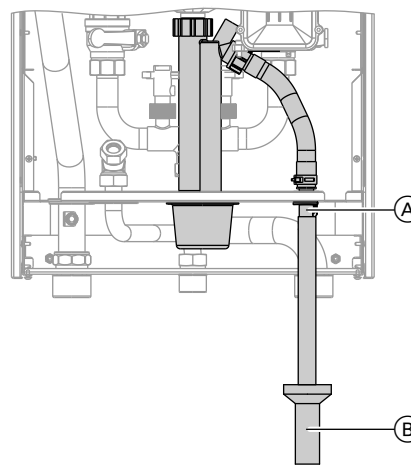

Vitodens 200-W, 69, 80 and 99 kW

- Ⓐ Drain hose (Vitodens standard delivery)
- Ⓑ Drain outlet kit (accessories)

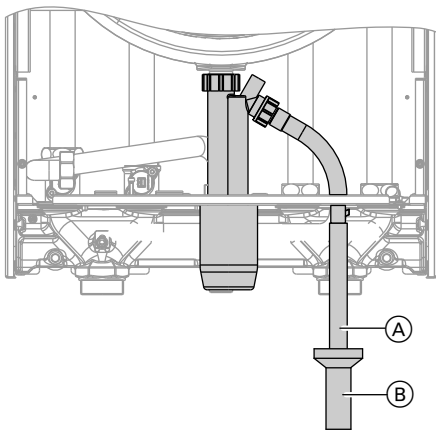

Vitodens 200-W, 120 and 150 kW

- (A) Drain hose (Vitodens standard delivery)
- (B) Drain outlet kit (accessories)

### Condensate drain pipe and neutralisation

Condensate created during heating operation, in both the condensing boiler and the flue pipe, must be drained off in accordance with appropriate regulations. With gas combustion, the condensate will have a pH value between 4 and 5.

Code of Practice DWA-A 251 on "Condensate from condensing boilers", which is generally based on the local waste water regulations [in Germany], determines conditions for draining condensate from condensing boilers into the public sewer system.

The composition of condensate drained from Vitodens condensing boilers meets the requirements specified in Code of Practice DWA-A 251.

The condensate drain pipe to the sewer connection must be freely accessible for inspection.

It must be installed with a continuous fall and must contain a stench trap. Also provide a suitable facility for sampling.

Condensate drain pipes must only be made from corrosion-resistant materials (e.g. reinforced hoses).

**Never use any zinc-plated materials or those containing copper for pipes, connection pieces, etc.**

A trap is installed in the condensate drain to prevent flue gases escaping.

Local water regulations and/or specific technical circumstances may prescribe designs that vary from those described in the above Codes of Practice.

It is advisable to contact the local water authorities in good time prior to installation in order to familiarise yourself with the local regulations.

#### Condensate from gas combustion equipment up to 200 kW combustion output

Up to a rated heating output of 200 kW, the condensate from a gas condensing boiler can generally be introduced into the public waste water system without prior neutralisation.

Also ensure that your domestic drainage systems are made from materials that are resistant to acidic condensate.

According to Code of Practice DWA-A 251, these materials include:

- Vitrified clay pipes
- Hard PVC pipes
- PVC pipes
- PE HD pipes
- PE pipes
- ABS/ASA pipes
- Stainless steel pipes
- Borosilicate pipes

### Neutralising system

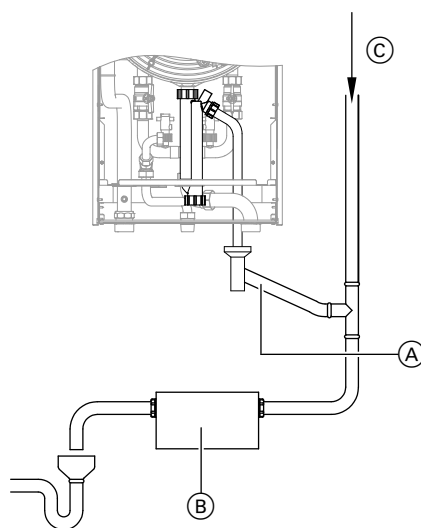

- (A) Condensate drain
- (B) Neutralising system
- (C) Ventilation via the roof

The Vitodens can (if required) be supplied with a separate neutralising system (accessories). Any condensate is piped to and processed in the neutralising system.

The condensate drain pipe to the sewer connection must be accessible for inspection. Install it with a fall and a stench trap on the sewer side, and provide a suitable facility for extracting samples.

Install a condensate lifting pump if the Vitodens has been installed below the waste water anti-flooding level.

Condensate lifting pumps are available as accessories (see the Vitodens pricelist).

Since the consumption of neutralising granulate depends on the operating mode of the system, carry out regular checks during the first year of operation to determine the required top-up volume. One fill can last longer than one year.

## Design information (cont.)

### Neutralising system for single boiler systems from 35 to 60 kW

Part no. ZK03653

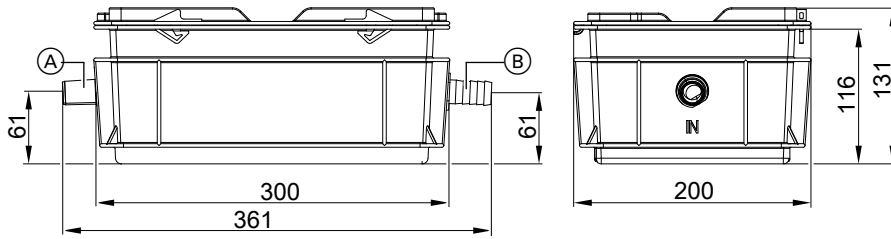

- (A) Inlet (DN 20)
- (B) Drain (DN 20)

### Neutralising system for single boiler systems from 80 kW and multi boiler systems up to 500 kW

Part no. 7441823

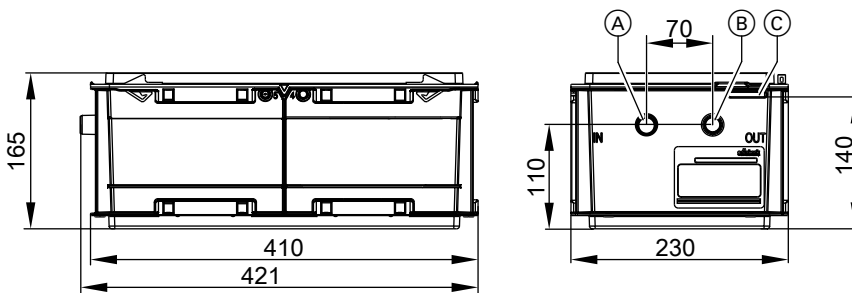

- (A) Inlet (DN 20)
- (B) Drain (DN 20)
- (C) Overflow aperture

### Neutralising system for multi boiler systems above 500 kW

Part no. 7437829

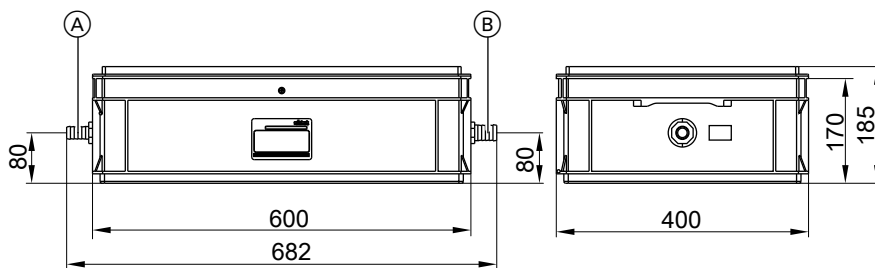

- (A) Inlet (DN 20)
- (B) Drain (DN 25)

### Neutralising system with wall mounting bracket

Part no. 7968319

- For condensing boilers 35 to 60 kW
- With neutralising granulate (3.5 kg)
- With connection elbows for DN 20 hose connection

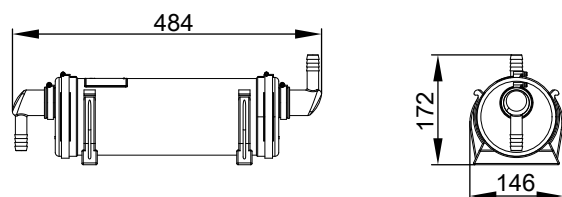

## Design information (cont.)

### Neutralising granulate

#### Part no. 7857854

3.5 kg

Fits neutralising system part no. 7968319

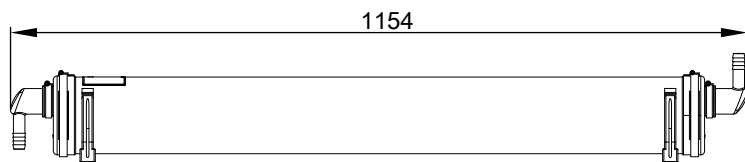

### Neutralising system with wall mounting bracket

#### Part no. 7968320

■ For condensing boilers 50 to 500 kW

■ With neutralising granulate (10.0 kg)

■ With connection elbows for DN 20 hose connection

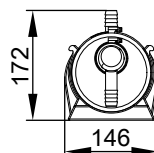

### Neutralising granulate

#### Part no. 7857855

2 x 5.0 kg

Fits neutralising system part no. 7968320

■ Fill level: 909 mm

■ With connection elbows for DN 20 hose connection

### Neutralising system

#### Part no. 7968321

■ For condensing boilers 50 to 500 kW

■ With neutralising granulate (10.0 kg)

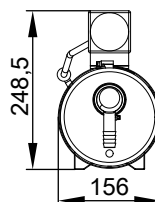
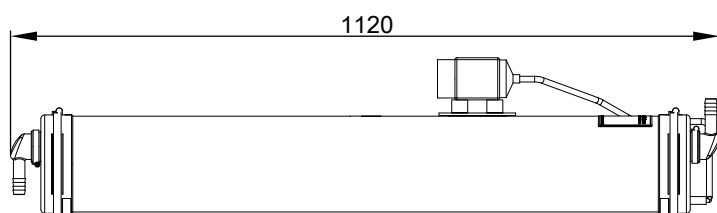

### Neutralising granulate

#### Part no. 7857856

4 x 5.0 kg

Fits neutralising system part no. 7968321

### Condensate lifting system

#### Part no. ZK02486

Automatic condensate removal pump for condensate with a pH value of  $\geq 2.8$  from gas condensing boilers

Components:

- Condensate container 2.0 l
- Centrifugal pump
- Non-return valve
- Connecting cable (1.5 m long) for fault messages
- Power cable (1.5 m long) with plug
- 4 connection apertures  $\varnothing 30$  mm for condensate drain with connector  $\varnothing$  max. 40 mm)
- Drain hose  $\varnothing 10$  mm (5 m long)

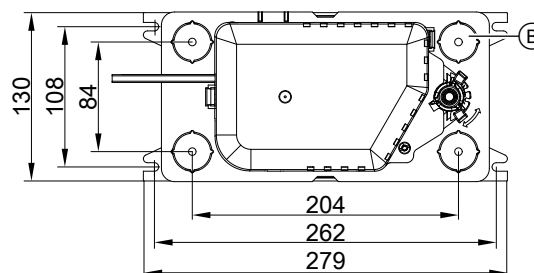
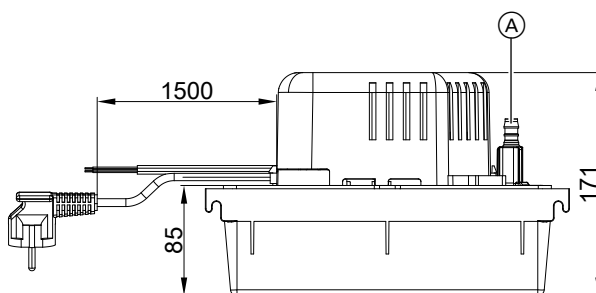

(A) Condensate drain

(B) 4 x condensate inlet (closed in delivered condition)



## Design information (cont.)

### Specification

Rated voltage	230 V~
Rated frequency	50 Hz
Power consumption	70 W
IP rating	IP 20

Permissible medium temperature	+65 °C
Max. head	50 kPa
Max. pump rate	500 l/h
Alarm contact	Changeover contact (floating), breaking capacity 250 V/4 A

## 4.3 Hydraulic connection

### General

#### System design

Viessmann condensing boilers can generally be installed in any fully pumped hot water heating system (sealed unvented system).

Connection sets with an integral circulation pump are available as accessories.

Minimum system pressure 1.0 bar (0.1 MPa).

The boiler water temperature is limited to 82 °C.

To minimise distribution losses, we recommend sizing the heat distribution system to a max. flow temperature of 70 °C.

The heat generator must be correctly sized and selected.

#### Chemical anti-corrosion agents

According to VDI guideline 2035, the design of heating systems must ensure they are sealed against corrosion. Additives in the heating water (additives, chemicals) as corrosion protection measures are normally not necessary.

Exception: In systems without system separation, for example, additives can be considered.

#### Heating circuits

For heating systems with plastic pipes, we recommend the use of impermeable pipes to prevent the diffusion of oxygen through the pipe walls.

Provide system separation in heating systems with plastic pipes that are permeable to oxygen (DIN 4726). A separate heat exchanger for this purpose is available.

Install a dirt separator in underfloor heating systems. See Viessmann Vitoset pricelist.

Underfloor heating systems and heating circuits with very large water content (>15 l/kW) should be connected to the condensing boiler via a 3-way mixer. See technical guide "Control of underfloor heating systems" or the relevant sample applications.

Install a temperature limiter in the flow of the underfloor heating circuit to restrict the maximum temperature. Observe the requirements of DIN 18560-2 [or local regulations].

#### Plastic pipework for radiators

We also recommend the use of a temperature limiter to restrict the maximum temperature for plastic pipework in heating circuits with radiators.

#### Safety valve

A safety valve in accordance with TRD 721 is part of the heating circuit connection set (accessories) (opening pressure 4 bar (0.4 MPa)).

Route the discharge pipe in accordance with EN 12828 into a drain outlet (drain outlet kit available as an accessory). The drain outlet incorporates a siphon as a stench trap.

#### Low water indicator

According to EN 12828, a low water indicator can be omitted for boilers up to 300 kW, as long as heating can be reliably prevented when there is a water shortage.

Viessmann condensing boilers are equipped with a low water indicator (boil-dry protection). Tests have verified that the burner will be automatically switched off in the event of water shortage due to a leak in the heating system and simultaneous burner operation, before the boiler or the flue system reaches unacceptably high temperatures.

#### Attic heating centre

The installation of a low water indicator, specified as compulsory to EN 12828, is not required when installing the Vitodens in an attic heating centre.

Vitodens condensing boilers are protected against water shortage in accordance with EN 12828.

#### Fill and top-up water

The quality of the fill and top-up water is one of the key factors for preventing damage caused by deposits or corrosion in the heating system.

In order to prevent system damage, the European standards and national guidelines for fill and top-up water must be observed right from the design stage, e.g. VDI 2035.

- Regular checks of the appearance, water hardness, conductivity and pH value of the heating water during operation lead to higher operational reliability and system efficiency. These properties must also be observed for the top-up water. According to VDI 2035, the quantity and properties of the top-up water must always be documented in the system log or maintenance reports.
- The basis for filling the heating system is tap water of potable water quality in line with Directive 98/83/EC and/or (EU) 2020/2184. For use as heating water, it is normally sufficient to soften the tap water. VDI 2035 specifies the maximum recommended concentrations of alkaline earths (hardeners), depending on the heating output and the specific system volume (ratio of the heating output of the heat generators to the heating water volume of the system): See the table below.
- We recommend always softening the fill and top-up water, as the water hardness can vary due to the mixture of different sources of supply, and the information provided by water supply utilities only gives average values. The information provided by water supply utilities is not sufficient for designing the system. In addition, it must be taken into account that the quantity of top-up water that will be added to the system during its service life cannot be predicted precisely at the design stage (especially in the case of existing heating circuits).
- If no aluminium or aluminium alloy components are installed, the heating water in systems with Viessmann heat generators does not need to be fully desalinated.



## Design information (cont.)

- The use of glycol as antifreeze without adequate inhibition and buffering is not permitted. The suitability of an antifreeze or other chemical additive should be certified by the manufacturer. Chemical additives in the heating water require more extensive monitoring and maintenance. Observe the manufacturer's instructions. Viessmann accepts no liability for damage or operational failure arising due to the use of unsuitable additives, incorrect dosing or poor maintenance.
- Chemical water treatments may only be planned and carried out by appropriately qualified specialist companies.

### Total permissible hardness of the fill and top-up water according to VDI 2035

Total heating output of heat generator	Specific water capacity of heat generator <sup>*13</sup>	Specific system volume <sup>*14</sup>		
		≤ 20 l/kW	> 20 to ≤ 40 l/kW	> 40 l/kW
≤ 50 kW	≥ 0.3 l/kW	None	≤ 3.0 mol/m <sup>3</sup> (16.8 °dH)	≤ 0.05 mol/m <sup>3</sup> (0.3 °dH)
	< 0.3 l/kW	≤ 3.0 mol/m <sup>3</sup> (16.8 °dH)	≤ 1.5 mol/m <sup>3</sup> (8.4 °dH)	≤ 0.05 mol/m <sup>3</sup> (0.3 °dH)
> 50 to ≤ 200 kW	—	≤ 2.0 mol/m <sup>3</sup> (11.2 °dH)	≤ 1.0 mol/m <sup>3</sup> (5.6 °dH)	≤ 0.05 mol/m <sup>3</sup> (0.3 °dH)
> 200 to ≤ 600 kW	—	≤ 1.5 mol/m <sup>3</sup> (8.4 °dH)	≤ 0.05 mol/m <sup>3</sup> (0.3 °dH)	≤ 0.05 mol/m <sup>3</sup> (0.3 °dH)
> 600 kW	—	≤ 0.05 mol/m <sup>3</sup> (0.3 °dH)	≤ 0.05 mol/m <sup>3</sup> (0.3 °dH)	≤ 0.05 mol/m <sup>3</sup> (0.3 °dH)

### Further requirements for the fill and top-up water independent of the heating output according to VDI 2035

#### Appearance

**Clear**, free of sedimented substances

#### Electrical conductivity

If the conductivity of the heating water is above **1500 µS/cm** due to a high salt content (e.g. in supply areas near the coast), desalination is necessary.

#### pH value

Materials in the system	pH value
Without aluminium alloys	8.2 to 10.0
With aluminium alloys	8.2 to 9.0

#### Information about system design

- For softening the heating water, use softening systems with water flow meters: See Vitoset pricelist.
- During installation, ensure that individual pipework sections can be drained separately. This avoids the need to drain all the heating water in the case of maintenance and repair work.
- As the formation of sludge and magnetite in the heating water cannot generally be completely prevented during operation, we recommend the installation of suitable magnetic dirt separators: See Vitoset pricelist.

#### Notes on commissioning and operating the system

- In order to prevent corrosion by remaining flushing water, fill the system completely immediately after flushing.
- Even treated fill water contains oxygen and small amounts of foreign matter. In order to prevent local concentrations of corrosion products and other deposits on the heating surfaces of the heat generator, commission the system in stages with a high heating water flow rate. Start with the heat generator at its lowest output. For the same reason, in the case of multi boiler systems and cascades, commission all heat generators at the same time.
- If extending the system or conducting maintenance or repair work, only drain the pipework sections where absolutely necessary.

<sup>\*13</sup> In the case of systems with several heat generators that have several different specific water capacities, the smallest specific water capacity is definitive.

<sup>\*14</sup> To calculate the specific system volume, the smallest individual heating output should be used for systems with several heat generators.

- Check and clean filters, dirt traps and other blow-down or separating facilities in the heating water circuit after filling and commissioning.
- Special regional regulations regarding fill and top-up water must be observed. When disposing of heating water containing additives, check whether additional treatment may be required before it is discharged into the public waste water system.

#### DHW heating

When operating a DHW cylinder, ensure that the heating output of the heat generator can be transferred to the DHW cylinder as continuously as possible. In borderline situations, we recommend operating the DHW cylinder in parallel mode with the heating circuit pump and circulation pump for cylinder heating (no cylinder priority).

By using the DHW cylinder connection set (accessories) the DHW cylinder can be connected upstream of the low loss header in combination with the heating circuit connection set with integral low loss header. Provide a venting facility on the heating water flow or return of the DHW cylinder during installation.

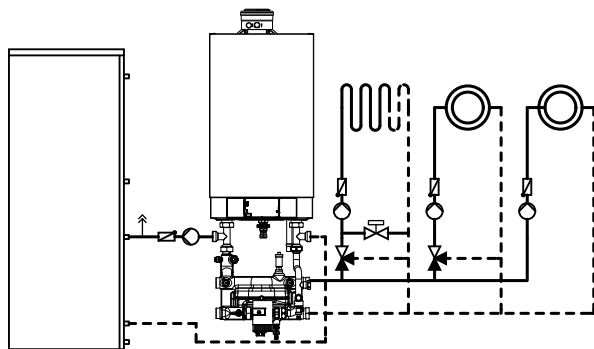

If the cylinder capacity is below the following values, we recommend connecting the DHW cylinder downstream of the low loss header on the secondary side of the heating system.

## Design information (cont.)

Rated boiler heating output	DHW cylinder capacity
49 to 80 kW	< 350 l
99 kW	< 400 l
120 and 150 kW	< 500 l

Always connect the DHW cylinder on the same side as the heating circuits. Connection on the opposite side is **not** permissible.

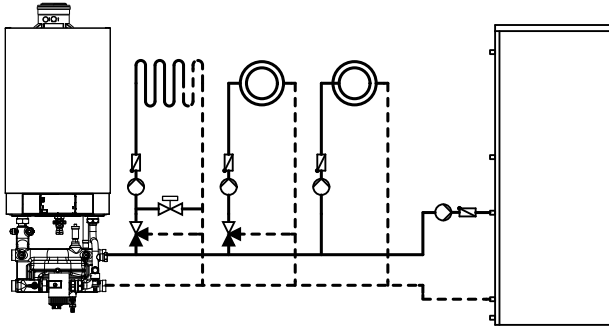

In conjunction with multi boiler systems, the DHW cylinder must be connected downstream of the low loss header on the secondary side of the heating system.

### Installation examples

Installation examples for the Vitodens 200-W can be found at: [www.viessmann-schemes.com](http://www.viessmann-schemes.com)

## Expansion vessels

In accordance with EN 12828, water heating systems must be equipped with an expansion vessel.

The size of the expansion vessel to be installed depends on the heating system specification and should be checked in each case.

## Multi boiler systems

We recommend the installation of a low loss header in multi boiler systems. For this, order the low loss header that is available as an accessory. See page 63 and the Viessmann pricelist.

Losses resulting from the use of third party low loss headers are excluded from our liability.

Safety equipment to EN 12828 must be provided on site.

As an alternative to the low loss header, a suitably sized plate heat exchanger may be used to provide system separation. In this case, the flow temperature sensor should be arranged on the secondary side of the plate heat exchanger. See the following system example.

### Information on the plate heat exchanger

- Provide air vent valves (e.g. quick-action air vent valves) on the primary side (boiler side) and the secondary side (heating circuit side) of the plate heat exchanger.
- Flush existing heating systems thoroughly before fitting the plate heat exchanger. The use of a sludge separator is recommended.
- Fit the flow temperature sensor into the flow connection on the secondary side, as shown in the diagram. Connection elbows with integral sensor well are available as accessories.
- Set the circulation pumps in the boiler connection sets to  $\Delta P$  constant and max. pump rate.
- The connection of several plate heat exchangers is not recommended.

Sizing the plate heat exchanger:

- The pressure drop in the plate heat exchanger must be lower than the lowest pressure drop of connected heating circuits.
- Fit a dirt trap on the secondary side of the plate heat exchanger.
- When sizing, take the temperature differential of the plate heat exchanger into account.

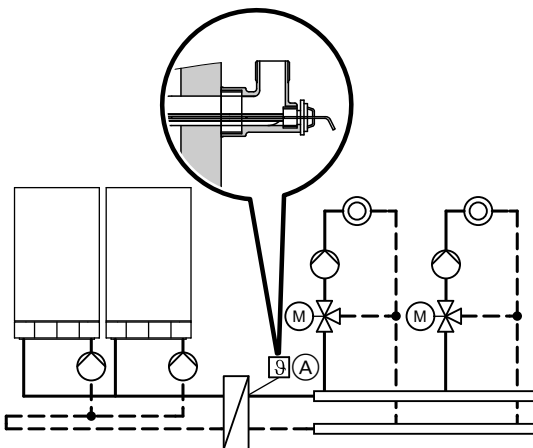

(A) Flow temperature sensor

## Max./min. flow rates Vitodens 200-W

5822432 Note the provided flow rates when using the heating circuit connection set without integral low loss header. Take appropriate measures on the system if these values are exceeded or not met.

## Design information (cont.)

Boiler	Max. flow rate l/h
Vitodens 200-W, 49 and 60 kW	3500
Vitodens 200-W, 69, 80 and 99 kW	5700
Vitodens 200-W, 120 kW	7165
Vitodens 200-W, 150 kW	8600

Boiler	Minimum flow rate l/h
Vitodens 200-W, 49 and 60 kW	450
Vitodens 200-W, 69, 80 and 99 kW	1300
Vitodens 200-W, 120 and 150 kW	3600

For installation designs in conjunction with connection sets with integral low loss header: See [www.viessmann-schemes.com](http://www.viessmann-schemes.com).

### Heat generator circuit

The circulation pump in the Vitodens must be able to supply the required water volume against the (mostly low) pressure drop of the boiler circuit. The pressure drop of the low loss header is negligible. Subject to the water volume circulating in the heat generator circuit, the respective residual head for sizing the internal pipe diameters may be determined using the pump diagram; alternatively the high efficiency circulation pumps can be adjusted accordingly.

### Heating circuit

The heating water pumps to be installed on site must be able to deliver the water volume in the heating circuits against their pressure drop, and must be sized accordingly.

### Low loss header with distributor/manifold for multi boiler systems with Vitodens 200-W

For description and specification, see page 63.

## 4.4 Intended use

The appliance is intended solely for installation and operation in sealed unvented heating systems that comply with EN 12828, with due attention paid to CECS 215-2017 and the associated installation, service and operating instructions. It is only designed for heating up heating water that is of potable water quality.

Intended use presupposes that a fixed installation in conjunction with permissible, system-specific components has been carried out.

The appliance is intended exclusively for domestic or semi-domestic use; even users who have not had any instruction are able to operate the appliance safely.

Commercial or industrial usage for a purpose other than heating the building or DHW shall be deemed inappropriate.

Any usage beyond this must be approved by the manufacturer in each individual case.

Incorrect usage or operation of the appliance (e.g. the appliance being opened by the system user) is prohibited and will result in an exclusion of liability. Incorrect usage also occurs if the components in the heating system are modified from their intended use (e.g. if the flue gas and ventilation air paths are sealed).

## Control units

### 5.1 Vitotronic 100, type HC1B constant temperature control unit

#### Layout and functions

##### Modular structure

The control unit is integrated into the boiler. The control unit comprises a standard unit, electronics modules and a programming unit.

Standard unit:

- ON/OFF switch
- Optolink laptop interface
- Operating and fault indicators
- Reset button
- Fuses

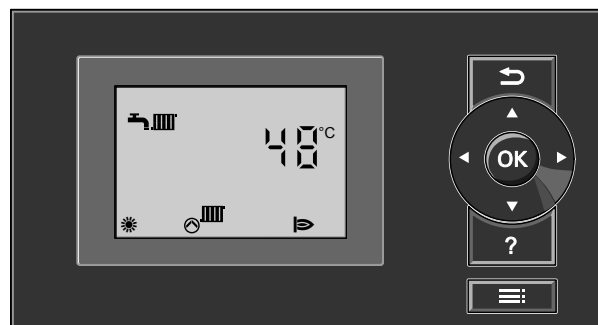

Programming unit:

- Easy operation through display with large font and depiction with good contrast
- Removable programming unit; can be mounted as option on the wall with separate accessory

## Control units (cont.)

- Menu prompts through pictograms
- Operating keys for:
  - Navigation
  - Confirmation
  - Settings/menu
- Settings:
  - Boiler water temperature
  - DHW temperature
  - Operating program
  - Codes
  - Actuator tests
  - Test mode
- Displaying:
  - Boiler water temperature
  - DHW temperature
  - Operating data
  - Diagnostic details
  - Fault messages

### Functions

- Electronic boiler control unit for operation at a constant boiler water temperature
- Room temperature-dependent operation requires a Vitotrol 100, type UTA, UTDB or UTDB-RF (according to GEG [Germany])
- Heating system frost protection monitoring
- Pump anti-seizing protection
- Integral diagnostic system
- Cylinder temperature controller with priority control
- Control of solar DHW heating and central heating backup in conjunction with solar control module, type SM1
- Auxiliary function for DHW heating (short-term heating to a higher temperature)
- Maintenance display
- External starting and blocking (in conjunction with EA1 extension)
- Connection of the circulation pump for cylinder heating on the main PCB

### Control characteristics

PI characteristics with modulating output.

### Setting the heating programs

The heating system frost protection (see frost protection function) applies to all heating programs.

The following heating programs can be selected:

- Heating and DHW
- Only DHW
- Standby mode

### Frost protection function

The frost protection function is active in all heating programs. The burner is switched ON at a boiler water temperature of 5 °C and will be switched OFF again at a boiler water temperature of 20 °C. The circulation pump will be switched ON simultaneously with the burner and switched OFF after a delay. The DHW cylinder will be heated to approx. 20 °C. To protect the system against frost, the circulation pump may be started at certain intervals (up to 24 times per day) for periods of approx. 10 minutes.

### Summer mode

Operating program "☀"

The burner starts only when the DHW cylinder needs to be heated up.

### Boiler water temperature sensor

The boiler water temperature sensor is connected to the control unit and built into the boiler.

#### Specification

Sensor type	Viessmann NTC 10 kΩ at 25 °C
Permissible ambient temperature	
– Operation	0 to +130 °C
– Storage and transport	–20 to +70 °C

### Cylinder temperature sensor

The standard delivery includes the DHW cylinder connection set.

#### Specification

Lead length	3.75 m, fully wired
IP rating	IP 32
Sensor type	Viessmann NTC 10 kΩ at 25 °C
Permissible ambient temperature	
– During operation	0 to +90 °C
– During storage and transport	–20 to +70 °C

## Specification Vitotronic 100, type HC1B

Rated voltage	230 V~
Rated frequency	50 Hz
Rated current	6 A
Protection class	I
Function type	Type 1 B to EN 60730-1
Permissible ambient temperature	0 to +40 °C Installation in living spaces or boiler rooms (standard ambient conditions)
– During operation	

– During storage and transport	–20 to +65 °C
Electronic temperature limiter setting (heating mode)	82 °C (change not possible)
Electronic high limit safety cut-out setting	100 °C (change not possible)
Setting range for DHW temperature	10 to 68 °C

## 5.2 Vitotronic 200, type HO1B weather-compensated control unit

### Design and functions

#### Modular design

The control unit is integrated into the boiler.

The control unit comprises a standard unit, electronics modules and a programming unit.

- Operating and fault indicators
- Reset button
- Fuses

Standard unit:

- ON/OFF switch
- Optolink laptop interface

5822432

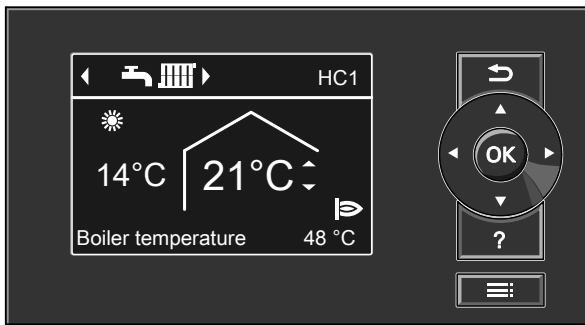

### Programming unit:

- Easy operation thanks to:
  - Plain text display with graphic ability
  - Large font and black/white depiction for good contrast
  - Context-sensitive help
  - Removable programming unit; can be mounted as option on the wall with separate accessory
- With digital time switch
- Operating keys:
  - Navigation
  - Confirmation
  - Help and additional information
  - Menu
- Attitude:
  - Room temperature
  - Reduced room temperature
  - DHW temperature
  - Operating program
  - Time programs for central heating, DHW heating and DHW circulation
  - Economy mode
  - Party mode
  - Holiday program
  - Heating curves
  - Codes
  - Actuator tests
  - Test mode
- Display:
  - Boiler water temperature
  - DHW temperature
  - Operating data
  - Diagnostic details
  - Fault messages
- Available languages:
  - German
  - Bulgarian
  - Czech
  - Danish
  - English
  - Spanish
  - Estonian
  - French
  - Croatian
  - Italian
  - Latvian
  - Lithuanian
  - Hungarian
  - Dutch
  - Polish
  - Russian
  - Romanian
  - Slovenian
  - Finnish
  - Swedish
  - Turkish

### Functions

- Weather-compensated control of the boiler water and/or flow temperature
- Control of one heating circuit without mixer and 2 heating circuits with mixer
- Electronic maximum and minimum temperature limit
- Demand-dependent heating circuit pump and burner shutdown control
- Variable heating limit setting
- Pump anti-seizing protection
- Heating system frost protection monitoring
- Integral diagnostic system
- Maintenance display
- Cylinder temperature controller with priority control
- In conjunction with solar control module, type SM1:
  - Control of solar DHW heating and central heating backup
  - Graphic representation of the solar energy yield
- Auxiliary function for DHW heating (short-term heating to a higher temperature)
- Screed drying program
- External starting and blocking (in conjunction with EA1 extension)
- Connection of the circulation pump for cylinder heating on the main PCB

To reduce the heat-up output, the reduced room temperature can be raised when outside temperatures are low. To shorten the heat-up time after a setback phase the flow temperature is raised for a limited time.

According to the GEG (German Buildings Energy Act), the temperature in each room must be individually controlled, e.g. by means of thermostatic valves.

### Control characteristics

PI characteristics with modulating output.

### Time switch

Digital time switch (integrated into the programming unit)

- Individual day and seven-day program
  - Automatic summer/wintertime changeover
  - Automatic function for DHW heating and DHW circulation pump
  - Time, day and standard switching times for central heating, DHW heating and the DHW circulation pump are factory-set
  - Switching times are individually programmable, i.e. up to four switching periods per day
- Shortest switching interval: 10 minutes  
Power reserve: 14 days

### Setting the operating programs

The heating system frost protection (see frost protection function) applies to all heating programs.

The following heating programs can be selected:

- Heating and DHW
- Only DHW
- Standby mode

External heating program changeover in conjunction with EA1 extension.

### Frost protection function

- The frost protection function is started when the outside temperature falls below approx. +1 °C.  
In the frost protection function, the heating circuit pump is started and the boiler water is maintained at a lower temperature of approx. 20 °C.  
The DHW cylinder is heated to approx. 20 °C.
- The frost protection function is stopped when the outside temperature exceeds approx. +3 °C.

### Summer mode

Operating program "☀"

The burner starts only when the DHW cylinder needs to be heated up.

## Control units (cont.)

### Adjusting the heating curves (slope and level)

The Vitotronic 200 controls the boiler water temperature (= flow temperature of the heating circuit without mixer) **and** the flow temperature of the heating circuits with mixer (in conjunction with the extension kit for one heating circuit with mixer) in weather-compensated mode. The boiler water temperature is automatically boosted by between 0 and 40 K higher than the currently required set flow temperature (delivered condition 8 K).

The flow temperature required to reach a specific room temperature depends on the heating system and the thermal insulation of the building to be heated.

Adjusting the heating curves matches the boiler water temperature and the flow temperature to these operating conditions.

Heating curves:

The upper boiler water temperature is limited by the temperature limiter and the temperature set at the electronic maximum thermostat.

The flow temperature cannot exceed the boiler water temperature.

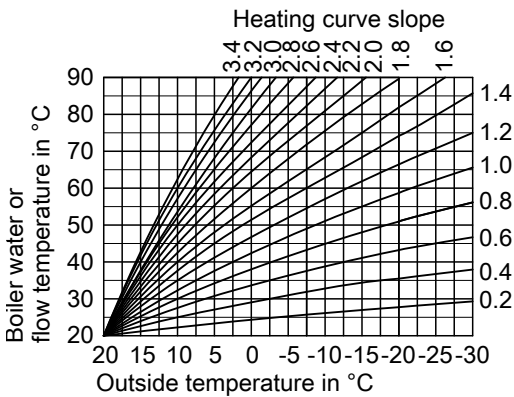

### Cylinder temperature sensor

The standard delivery includes the DHW cylinder connection set.

#### Specification

Lead length	3.75 m, fully wired
IP rating	IP 32
Sensor type	Viessmann NTC 10 kΩ at 25 °C
Permissible ambient temperature	
– During operation	0 to +90 °C
– During storage and transport	–20 to +70 °C

### Outside temperature sensor

#### Installation location

- North or north-west facing wall of the building
- 2 to 2.5 m above the ground; for multi storey buildings in the upper half of the second floor

#### Connection

- 2-core lead, length up to 35 m with a cross-section of 1.5 mm<sup>2</sup> (copper)
- Never route this cable immediately next to 230/400 V cables.

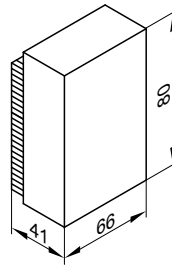

### Heating systems with low loss header

When using hydraulic separation (low loss header), connect a temperature sensor for use in the low loss header.

### Boiler water temperature sensor

The boiler water temperature sensor is connected to the control unit and built into the boiler.

#### Specification

Sensor type	Viessmann NTC 10 kΩ at 25 °C
Permissible ambient temperature	
– Operation	0 to +130 °C
– Storage and transport	–20 to +70 °C

#### Specification

IP rating	IP 43 to EN 60529; ensure through design/installation.
Sensor type	Viessmann NTC 10 kΩ at 25 °C
Permissible ambient temperature during operation, storage and transport	–40 to +70 °C

### Specification Vitotronic 200, type HO1B

Rated voltage	230 V~
Rated frequency	50 Hz
Rated current	6 A
Protection class	I
Permissible ambient temperature	
– During operation	0 to +40 °C Installation in living spaces or boiler rooms (standard ambient conditions)
– During storage and transport	–20 to +65 °C

Electronic temperature limiter setting (heating mode)	82 °C (cannot be changed)
Electronic high limit safety cut-out setting	100 °C (cannot be changed)
Setting range for DHW temperature	10 to 68 °C
Setting range for heating curve	
Slope	0.2 to 3.5
Level	–13 to 40 K

### 5.3 Vitotronic 300-K, type MW2B for multi boiler systems

#### Cascade control unit for Vitodens 200-W with Vitotronic 100

Weather-compensated digital cascade and heating circuit control unit

- For multi boiler systems with Vitodens 200-W
- With boiler sequence strategy
- For up to 2 heating circuits with mixer (extension for heating circuits 2 and 3 required as accessories).  
Up to a further 32 Vitotronic 200-H heating circuit control units can be connected via LON (LON communication module required; accessories)
- For modulating operation in conjunction with Vitotronic 100, type HC1B

- With cylinder temperature controller or control of a cylinder loading system with mixer assembly
- Capable of communicating via LON (LON communication module and terminators available as accessories)
- With integral diagnostic system.

#### Note

*To improve the resilience to interference/faults, the components of a control unit should be connected to the same phase.*

#### Design and function

##### Modular design

The control unit comprises a standard unit, electronics modules and a programming unit.

Standard unit:

- ON/OFF switch
- Emissions test switch
- Optolink laptop interface
- Operating and fault display
- Plug wiring chamber
  - Connection of external equipment via system plugs
  - Plugs are inserted directly into the front of the open control unit
  - Connection of three-phase consumers via additional contactors

Programming unit:

- Easy operation through:
  - Plain text display with graphic ability
  - Large font and black/white depiction for good contrast
  - Context-sensitive help texts
- With digital time switch
- Operating keys for:
  - Navigation
  - Confirmation
  - Help and additional information
  - Extended menu
- Adjustment of:
  - Room temperature
  - Reduced room temperature
  - DHW temperature
  - Operating program
  - Time programs for room heating, DHW heating and DHW circulation
  - Economy mode
  - Party mode
  - Holiday program
  - Heating curves
  - Codes
  - Actuator tests
  - Test mode

- Display of:
  - Flow temperature
  - DHW temperature
  - Information
  - Operating data
  - Diagnostic data
  - Fault messages
- Available languages:
  - German
  - Bulgarian
  - Czech
  - Danish
  - English
  - Spanish
  - Estonian
  - French
  - Croatian
  - Italian
  - Latvian
  - Lithuanian
  - Hungarian
  - Dutch
  - Polish
  - Russian
  - Romanian
  - Slovenian
  - Finnish
  - Swedish
  - Turkish

##### Functions

- Weather-compensated control of the system/boiler water temperature in a multi boiler system with Vitodens 200-W with Vitotronic 100, type HC1B (modulating) and the flow temperature of the heating circuits with mixer
- Control of the Vitotronic 100, type HC1B in boilers in accordance with a freely selectable boiler sequence strategy
- Electronic maximum temperature limit
- Demand-dependent heating circuit pump shutdown
- Variable heating limit setting
- Pump anti-seizing protection
- Central fault message
- Integral diagnostic system
- Adaptive cylinder temperature control with priority control (heating circuit pump off, mixer close)
- Auxiliary function for DHW heating (short-term heating to a higher temperature)
- Control of a cylinder loading system with a regulated 3-way mixing valve
- Screed drying for underfloor heating systems



## Control units (cont.)

To reduce the heat-up output, the reduced room temperature can be raised when outside temperatures are low. To shorten the heat-up time after a setback phase the flow temperature is raised for a limited time.

According to the GEG (German Buildings Energy Act), the temperature in each room must be individually controlled, e.g. by means of thermostatic valves.

### DHW heating in a multi boiler system

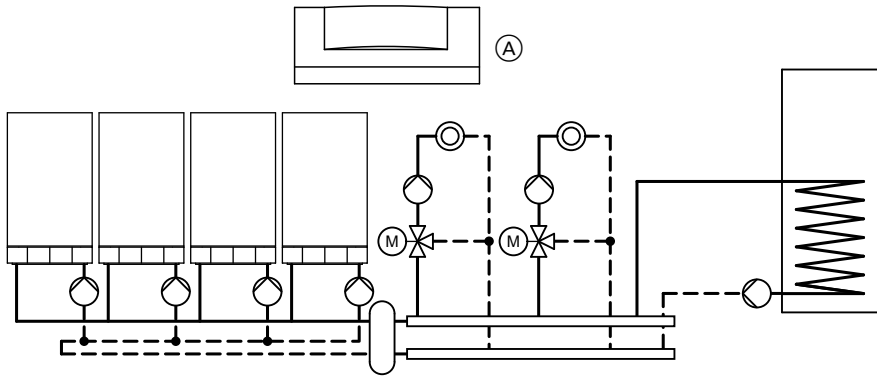

(A) Vitotronic 300-K

#### Control characteristics

- PI characteristics with three-point output
- Setting range for heating curves:
  - Slope: 0.2 to 3.5
  - Level: -13 to 40 K
  - Max. limit: 1 to 127 °C
  - Min. limit: 1 to 127 °C
  - Differential temperature for heating circuits with mixer: 0 to 40 K
- Setting range of the set DHW temperature:
  - Between 10 and 60 °C, adjustable to between 10 and 95 °C (available temperature limited by the max. boiler flow temperature).

#### Time program

- Individual day and seven-day program, holiday program
- Automatic summer/wintertime changeover
- Automatic function for DHW heating and DHW circulation pump
- Time, day and standard switching times for central heating, DHW heating and the DHW circulation pump are factory-set
- Switching times are individually programmable; up to 4 time phases per day

Shortest switching interval: 10 min

Power reserve: 14 days

#### Setting the operating programs

Frost protection monitoring (see frost protection function) for the heating system is enabled in all operating programs.

You can select the following operating programs with the program selectors:

- Heating and DHW
- Only DHW
- Standby mode

External changeover of operating program possible for all heating circuits together or for selected heating circuits only.

#### Connectivity

Vitoconnect 100, type OPTO2 (accessories):

WiFi interface for remote control of the heating system via the Vitotrol Plus or ViCare app. For further information, see the data communication technical guide.

#### Frost protection function

- The frost protection function is started when the outside temperature falls below approx. +1 °C.
  - In the frost protection function, the heating circuit pump is started and the boiler water is maintained at a lower temperature of approx. 20 °C.
  - The DHW cylinder is heated to approx. 20 °C.
- The frost protection function is stopped when the outside temperature exceeds approx. +3 °C.

#### Summer mode

("DHW only")

One or more burners start when the DHW cylinder needs to be heated up (controlled by the cylinder temperature controller).

#### Heating curve setting (slope and level)

Subject to heating system:

- The Vitotronic controls the flow temperature of up to 2 heating circuits with mixer in weather-compensated mode
- The Vitotronic automatically regulates the system flow temperature to 0 to 40 K (delivered condition 8 K) higher than the highest currently set flow temperature

The flow temperature required to reach a specific room temperature depends on the heating system and the thermal insulation of the building to be heated.

Adjusting the heating curves matches the system flow temperature and the heating circuit flow temperature to these operating conditions.

## Control units (cont.)

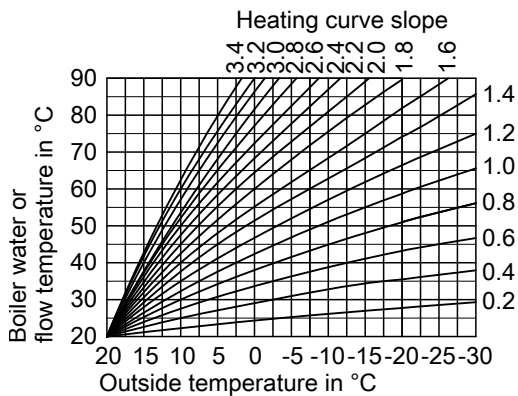

The upper flow temperature is limited by temperature controller "G" and the electronically set maximum temperature of the Vitotronic 100 boiler control units, type HC1B.

### Outside temperature sensor

#### Installation location

- North or north-west facing wall of the building
- 2 to 2.5 m above the ground; for multi storey buildings in the upper half of the second floor

#### Connection

- 2-core lead, length up to 35 m with a cross-section of 1.5 mm<sup>2</sup> (copper)
- Never route this cable immediately next to 230/400 V cables.

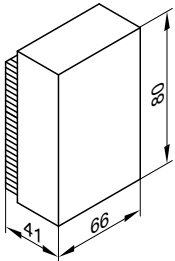

### Specification

IP rating	IP 43 to EN 60529; ensure through design/installation.
Sensor type	Viessmann NTC 10 kΩ at 25 °C
Permissible ambient temperature during operation, storage and transport	-40 to +70 °C

### Immersion temperature sensor

To capture the common flow temperature of the multi boiler system. Inserted into the sensor well of the low loss header or secured with a tie.

### Specification

Lead length	5.8 m, fully wired
IP rating	IP 32 to EN 60529
Sensor type	Viessmann NTC 10 kΩ at 25 °C
Permissible ambient temperature	
– During operation	0 to +90 °C
– During storage and transport	-20 to +70 °C

### Cylinder temperature sensor

#### Specification

Lead length	5.8 m, fully wired
IP rating	IP 32 to EN 60529
Sensor type	Viessmann NTC 10 kΩ at 25 °C
Permissible ambient temperature	
– During operation	0 to +90 °C
– During storage and transport	-20 to +70 °C

## Specification, Vitotronic 300-K

Rated voltage:	230 V ~
Rated frequency:	50 Hz
Rated current:	6 A
Power consumption:	10 W
Protection class:	I
IP rating:	IP 20 D to EN 60529; ensure through design/ installation
Function type:	Type 1B to EN 60730-1
Permissible ambient temperature	
– During operation:	0 to +40 °C, for use in the living space or boiler room (standard ambient conditions)
– During storage and transport:	-20 to +65 °C
Rated relay output breaking capacity:	
– Heating circuit pumps or heat exchanger set [20]:	4(2) A 230 V~

– Circulation pump for cylinder heating [21]:	4(2) A 230 V~
– DHW circulation pump [28]:	4(2) A 230 V~
– Distribution pump [29]:	4(2) A 230 V~
– Central fault message [50]:	4(2) A 230 V~
– Motor, 3-way mixing valve, cylinder loading system or Mixer motor [52]:	0.2(0.1) A 230 V~
– Overall max.	6 A 230 V~

### Power supply for DHW circulation pump

DHW circulation pumps equipped with their own internal control unit must be connected via a separate power supply. Power supply via the Vitotronic control unit or Vitotronic accessories is **not** permissible.

## Control units (cont.)

### Dimensions

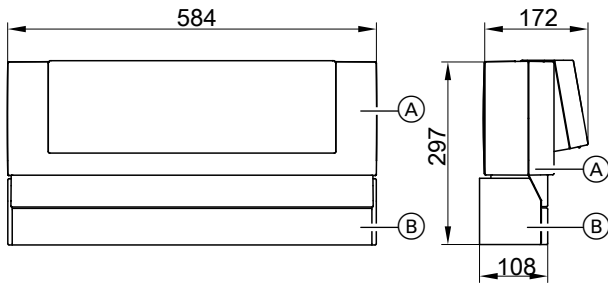

- (A) Vitotronic 300-K  
(B) Mounting bracket

### Delivered condition Vitotronic 300-K

- Programming unit with backlit plain text display
- Cascade communication module (corresponding to the number of Vitodens)
- Outside temperature sensor
- Flow temperature sensor
- Cylinder temperature sensor
- Mounting bracket

The control unit is fitted to the wall with a mounting bracket.  
To control the heating circuits with mixer, the extension for heating circuits 2 and 3 is required (accessories).

An extension kit (accessories) is required for each heating circuit with mixer.  
The LON communication module and BUS terminators are available as accessories to enable communication.

#### Heating system with DHW cylinder

Order the circulation pump with check valve or the Vitotrans 222 cylinder loading system separately.

## 5.4 Accessories for the Vitotronic

### Allocation to control unit types

Vitotronic	100	200	300-K
Type	HC1B	HO1B	MW2B
<b>Accessories</b>			
Vitotrol 100, type UTA	x		
Vitotrol 100, type UTDB	x		
External H4 extension	x		
Vitotrol 100, type UTDB-RF	x		
Vitotrol 200-A		x	x
Vitotrol 300-A		x	x
Vitotrol 200-RF		x	x
Wireless base station		x	x
Wireless repeater		x	x
Room temperature sensor for Vitotrol 300-A		x	x
Immersion temperature sensor	x	x	x
KM-BUS distributor	x	x	x
Mixer extension kit with integrated mixer motor		x	
Mixer extension kit for separate mixer motor		x	
Mixer motor		x	x
Extension for heating circuits 2 and 3 with mixer			x
Mixer extension kit			x
Immersion thermostat		x	x
Contact thermostat		x	x
Solar control module, type SM1	x	x	x
Internal H1 extension	x	x	
Internal H2 extension	x	x	
AM1 extension	x	x	
EA1 extension	x	x	x
LON cable		x	x
LON coupling		x	x
LON connection piece		x	x

## Control units (cont.)

Vitotronic	100	200	300-K
Type	HC1B	HO1B	MW2B
<b>Accessories</b>			
LON socket		x	x
Terminator		x	x
LON communication module		x	x
Vitocconnect 100, type OPTO2 (in conjunction with single appliances)		x	

### Vitotrol 100, type UTA

#### Part no. 7170149

##### Room thermostat

- With switching output (2-point output)
- With analogue time switch
- With adjustable individual day program
- Standard switching times are factory-set (individually programmable).
- Shortest switching interval 15 minutes

The Vitotrol 100 is installed in the main living room on an internal wall opposite radiators, although never inside shelving units, in recesses, or immediately by a door or heat source (e.g. direct sunlight, fireplace, TV set, etc.).

##### Control unit connection:

3-core cable with a cross-section of 1.5 mm<sup>2</sup> (no green/yellow wire) for 230 V~.

#### Specification

Rated voltage	230 V/50 Hz
Rated breaking capacity of the contact	6(1) A 250 V~
IP rating	IP 20 to EN 60529 Ensure through design/installation
Protection class	II
Permissible ambient temperature	
– Operation	0 to +40 °C
– Storage and transport	–20 to +60 °C
Set value setting range for standard mode and reduced mode	10 to 30 °C
Set room temperature in standby mode	6 °C

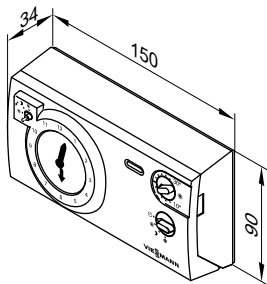

### Vitotrol 100, type UTDB

#### Part no. Z007691

##### Room temperature controller

- With switching output (2-point output)
- With digital time switch
- With individual day and seven-day program
- Operation with user prompts:
  - 3 preselected time programs, individually adjustable
  - Constant manual mode with adjustable set room temperature
  - Frost protection mode
  - Holiday program
- With selector keys for party and economy mode

Installation in the main living room on an internal wall opposite radiators. Never install inside shelving units, in recesses, or immediately by a door or heat source (e.g. direct sunlight, fireplace, TV set, etc.). Operation independent of mains power supply (2 x 1.5 V Mignon alkaline batteries, type LR6/AA, battery life approx. 1.5 years).

##### Control unit connection:

- 2-core cable with a cross-section of 0.75 mm<sup>2</sup> for extra low voltage (ELV)
- 2-core cable with a cross-section of 1.5 mm<sup>2</sup> for 230 V~

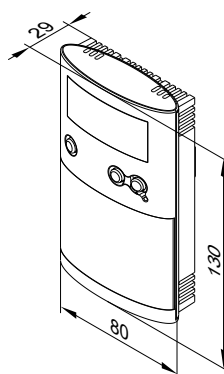

#### Specification

Rated voltage	3 V– Battery LR6/AA
Rated breaking capacity of the floating contact	
– max.	6(1) A, 230 V~
– min.	1 mA, 5 V–
IP rating	IP 20 to EN 60529 Ensure through design/installation
Protection class	II

## Control units (cont.)

Function type	RS type 1B to EN 60730-1
Permissible ambient temperature	
– Operation	0 to +40 °C
– Storage and transport	–25 to +65 °C
Setting range	
– Comfort temperature	10 to 40 °C
– Setback temperature	10 to 40 °C
– Frost protection temperature	5 °C
Power reserve during battery change	3 min

### External H4 extension

#### Part no. 7197227

- Connection extension for connecting the Vitotrol 100, type UTDB or 24 V clock thermostats via a LV lead
- With cable (0.5 m long) and plug for the connection to the control unit

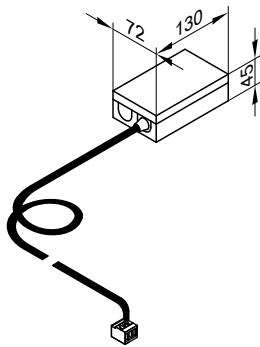

#### Specification

Rated voltage	230 V~
Output voltage	24 V~
Rated frequency	50 Hz
Power consumption	2.5 W
Load 24 V~ (max.)	10 W
Safety category	I
IP rating	IP 41
Permissible ambient temperature	
– Operation	0 to +40 °C Installation in living spaces or boiler rooms (standard ambient conditions)
– Storage and transport	–20 to +65 °C

### Vitotrol 100, type UTDB-RF

#### Part no. Z007692

Room temperature controller with integral wireless transmitter and receiver

- With digital time switch
- With individual day and seven-day program
- Operation with user prompts:
  - 3 preselected time programs, individually adjustable
  - Constant manual mode with adjustable set room temperature
  - Frost protection mode
  - Holiday program
- With selector keys for party and economy mode

Installation in the main living room on an internal wall opposite radiators. Never install inside shelving units, in recesses, or immediately by a door or heat source (e.g. direct sunlight, fireplace, TV set, etc.). Room temperature controller operation independent of mains power supply (2 x 1.5 V Mignon alkaline batteries, type LR6/AA, battery life approx. 1.5 years). Receiver with relay state indication.

Connection of the receiver to the control unit (subject to control unit type):

- 4-core cable with a cross-section of 1.5 mm<sup>2</sup> for 230 V~ or
- 3-core cable without green/yellow wire for 230 V~ or
- 2-core lead with a cross-section of 0.75 mm<sup>2</sup> for LV for the connection to the control unit, plus an additional 2-core cable for the 230 V~ power supply

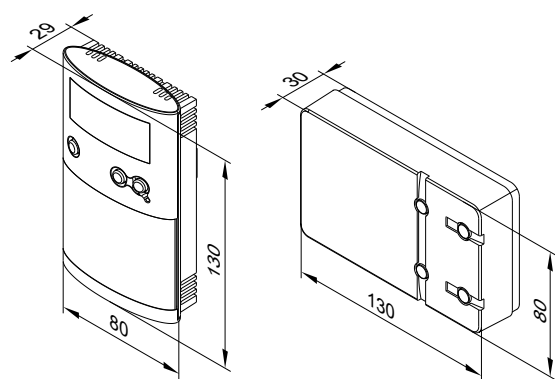

#### Specification, room temperature controller

Rated voltage	3 V–
Transmission frequency	868 MHz
Transmission	< 10 mW
Range	approx. 10 to 30 m inside buildings, subject to construction
IP rating	IP 20 to EN 60529 Ensure through design/installation
Function type	RS type 1B to EN 60730-1
Permissible ambient temperature	
– Operation	0 to +40 °C
– Storage and transport	–25 to +65 °C

## Control units (cont.)

Setting range	
– Comfort temperature	10 to 40 °C
– Setback temperature	10 to 40 °C
– Frost protection temperature	5 °C
Power reserve during battery change	3 min

### Specification, receiver

Operating voltage	230 V~ ± 10 % 50 Hz
Rated breaking capacity of the floating contact	
– max.	6(1) A, 230 V~
– min.	1 mA, 5 V–

IP rating	IP 20 to EN 60529 Ensure through design/installation
Safety category	II to EN 60730-1 subject to correct installation
Permissible ambient temperature	
– Operation	0 to +40 °C
– Storage and transport	–25 to +65 °C

## Notes regarding room temperature hook-up (RS function) for remote control units

Never activate the RS function for underfloor heating circuits (inertia).

In heating systems with a heating circuit without mixer and heating circuits with mixer, the RS function must only affect the heating circuit with mixer.

## Information on the Vitotrol 200-A and Vitotrol 300-A

For every heating circuit in a heating system, a Vitotrol 200-A or Vitotrol 300-A can be used.

The Vitotrol 200-A can regulate one heating circuit; the Vitotrol 300-A up to three heating circuits.

Up to two remote controls can be connected to the control unit.

### Note

Hardwired remote control units cannot be combined with the wireless base station.

## Vitotrol 200-A

### Part no. Z008341

KM BUS subscriber

#### ■ Displays:

- Room temperature
- Outside temperature
- Operating condition

#### ■ Settings:

- Set room temperature for standard mode (normal room temperature)

### Note

The set room temperature for reduced mode (reduced room temperature) is set at the control unit.

- Operating program

- Party and economy mode can be enabled via keys
- Integral room temperature sensor for room temperature hook-up (only for one heating circuit with mixer)

Installation location:

- Weather-compensated mode: installation anywhere in the building
- Room temperature hook-up: the integral room temperature sensor captures the actual room temperature and effects any necessary correction of the flow temperature.

The captured room temperature depends on the installation site:

- Main living room on an internal wall opposite radiators
- Not on shelves or in recesses
- Never in the immediate vicinity of doors or close to heat sources (e.g. direct insolation, fireplace, TV set, etc.).

Connection:

- 2-core lead, length max. 50 m (even if connecting several remote control units)
- Never route this cable immediately next to 230/400 V cables.
- LV plug as standard delivery

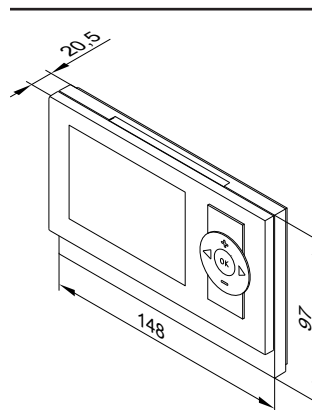

### Specification

Power supply	Via KM BUS
Power consumption	0.2 W
Protection class	III
IP rating	IP 30 to EN 60529; ensure through design/installation
Permissible ambient temperature	
– Operation	0 to +40 °C
– Storage and transport	–20 to +65 °C
Setting range of the set room temperature for standard mode	3 to 37 °C

### Notes

- If the Vitotrol 200-A is to be used for room temperature hook-up, site the device in a main living room (lead room).
- Connect a maximum of 2 Vitotrol 200-A units to the control unit.

## Control units (cont.)

### Vitotrol 300-A

#### Part no. Z008342

KM BUS subscriber

- Displays:
  - Room temperature
  - Outside temperature
  - Operating program
  - Operating condition
  - Graphic illustration of the solar energy yield in conjunction with the solar control module, type SM1
- Settings:
  - Set room temperature for standard mode (normal room temperature) and reduced mode (reduced room temperature)
  - Set DHW temperature
  - Operating program, switching times for heating circuits, DHW heating and DHW circulation pump plus further settings via plain text menu on the display
- Party and economy mode can be enabled via the menu
- Integral room temperature sensor for room temperature hook-up (only for one heating circuit with mixer)

Installation location:

- Weather-compensated mode: installation anywhere in the building
- Room temperature hook-up: the integral room temperature sensor captures the actual room temperature and effects any necessary correction of the flow temperature.

The captured room temperature depends on the installation site:

- Main living room on an internal wall opposite radiators
- Not on shelves or in recesses
- Never in the immediate vicinity of doors or close to heat sources (e.g. direct insolation, fireplace, TV set, etc.).

Connection:

- 2-core lead, length max. 50 m (even if connecting several remote control units)
- Never route this cable immediately next to 230/400 V cables.
- LV plug as standard delivery

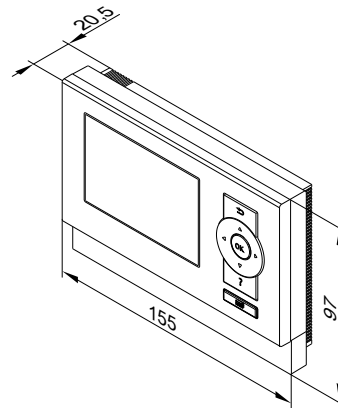

#### Specification

Power supply via KM BUS	
Power consumption	0.5 W
Protection class	III
IP rating	IP 30 to EN 60529; ensure through design/installation
Permissible ambient temperature	
– Operation	0 to +40 °C
– Storage and transport	–20 to +65 °C
Setting range for set room temperature	3 to 37 °C

### Information on Vitotrol 200-RF

Wireless remote control unit with integral wireless transmitter for operation with the wireless base station.

A Vitotrol 200-RF can be used for each heating circuit in a heating system.

The Vitotrol 200-RF can control one heating circuit.

Up to 3 wireless remote control units can be connected to the control unit.

#### Note

The wireless remote control **cannot** be combined with hardwired remote control units.

### Vitotrol 200-RF

#### Part no. Z011219

Wireless subscriber

- Displays:
  - Room temperature
  - Outside temperature
  - Operating condition
  - Wireless signal reception quality
- Settings:
  - Set room temperature for standard mode (normal room temperature)

#### Note

The set room temperature for reduced mode (reduced room temperature) is set at the control unit.

- Operating program

- Party and economy mode can be enabled via keys
- Integral room temperature sensor for room temperature hook-up (only for one heating circuit with mixer)

Installation location:

- Weather-compensated mode: Installation anywhere in the building
- Room temperature hook-up: The integral room temperature sensor captures the room temperature and effects any necessary correction of the flow temperature.

The captured room temperature depends on the installation site:

- Main living room on an internal wall opposite radiators
- Not on shelves or in recesses
- Never in the immediate vicinity of doors or close to heat sources (e.g. direct insolation, fireplace, TV set, etc.)

## Control units (cont.)

### Note

Observe the "Wireless accessories" technical guide.

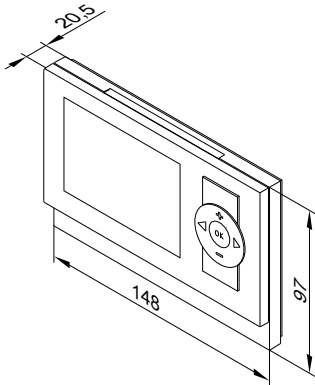

### Specification

Power supply	2 AA batteries 3 V
Radio frequency	868 MHz
Wireless range	See "Wireless accessories" technical guide
Protection class	III
IP rating	IP 30 to EN 60529; ensure through design/installation
Permissible ambient temperature	
– Operation	0 to +40 °C
– Storage and transport	–20 to +65 °C
Setting range of the set room temperature for standard mode	3 to 37 °C

## Wireless base station

### Part no. Z011413

KM-BUS subscribers

For communication between the Vitotronic control unit and Vitotrol 200-RF wireless remote control.

For up to 3 wireless remote control units. Not in conjunction with a hardwired remote control unit.

Connection:

- 2-core lead, length up to 50 m (even when connecting several KM-BUS subscribers).
- Never route this cable immediately next to 230/400 V cables.

### Specification

Power supply via KM-BUS	
Power consumption	1 W
Radio frequency	868 MHz
Protection class	III
IP rating	IP 20 to EN 60529; ensure through design/installation
Permissible ambient temperature	
– Operation	0 to +40 °C
– Storage and transport	–20 to +65 °C

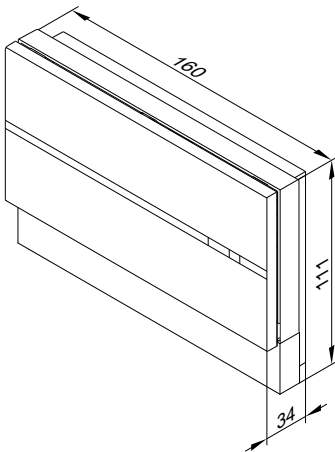

## Wireless repeater

### Part no. 7456538

Mains operated wireless repeater to increase the wireless range and for use in areas where wireless communication is difficult. Observe the "Wireless accessories" technical guide.

Do not use more than one wireless repeater per Vitotronic control unit.

- For preventing strongly diagonal angles of penetration of the radio signals through steel reinforced concrete ceilings/floors and/or multiple walls
- For circumventing large metallic objects situated between the wireless components.



## Control units (cont.)

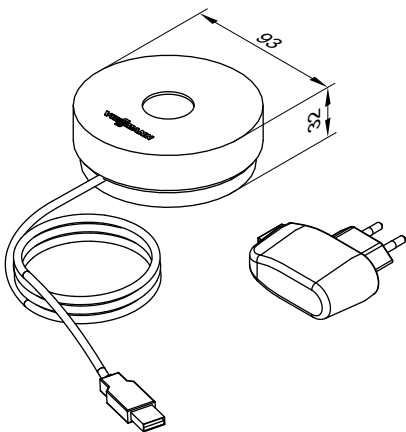

### Specification

Power supply	230 V~/5 V <sub>DC</sub> via plug-in power supply unit
Power consumption	0.25 W
Radio frequency	868 MHz
Lead length	1.1 m with plug
Safety category	II
IP rating	IP 20 to EN 60529; ensure through design/installation
Permissible ambient temperature	
– Operation	0 to +55 °C
– Storage and transport	–20 to +75 °C

## Room temperature sensor

### Part no. 7438537

Separate room temperature sensor as supplement to the Vitotrol 300A; to be used if the Vitotrol 300A cannot be installed inside the main living room or in a suitable position for temperature capture and adjustment.

Installation in the main living room on an internal wall opposite radiators. Never install inside shelving units, in recesses, or immediately by a door or heat source e.g. direct insolation, fireplace, TV set, etc. Connect the room temperature sensor to the Vitotrol 300A.

Connection:

- 2-core lead with a cross-section of 1.5 mm<sup>2</sup> (copper)
- Max. lead length from the remote control: 30 m
- Never route this cable immediately next to 230/400 V cables.

### Specification

Protection class	III
IP rating	IP 30 to EN 60529; ensure through design/installation
Sensor type	Viessmann NTC 10 kΩ at 25 °C
Permissible ambient temperature	
– Operation	0 to +40 °C
– Storage and transport	–20 to +65 °C

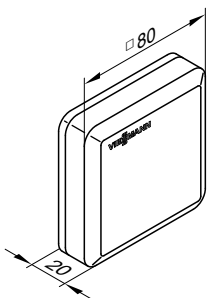

## Immersion temperature sensor

### Part no. 7438702

To capture a temperature in a sensor well

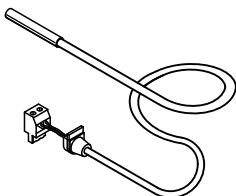

### Specification

Lead length	5.8 m, fully wired
IP rating	IP 32 to EN 60529; ensure through design/installation.
Sensor type	Viessmann NTC 10 kΩ, at 25 °C
Permissible ambient temperature	
– Operation	0 to +90 °C
– Storage and transport	–20 to +70 °C

## Immersion temperature sensor

### Part no. 7179488

To capture the low loss header temperature

## Control units (cont.)

### Specification

Lead length	3.75 m, fully wired
IP rating	IP 32 to EN 60529; ensure through design/installation
Sensor type	Viessmann NTC 10 kΩ at 25 °C
Permissible ambient temperature	
– Operation	0 to +90 °C
– Storage and transport	–20 to +70 °C

### KM BUS distributor

#### Part no. 7415028

For the connection of 2 to 9 devices to the control unit KM-BUS

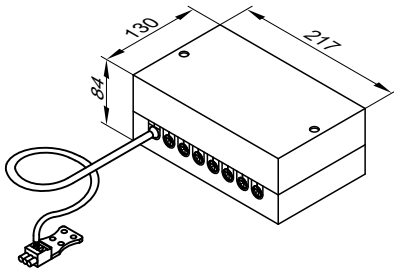

### Specification

Lead length	3.0 m, fully wired
IP rating	IP 32 to EN 60529; ensure through design/installation
Permissible ambient temperature	
– Operation	0 to +40 °C
– Storage and transport	–20 to +65 °C

### Mixer extension kit with integral mixer motor

#### Part no. ZK02940

KM BUS subscriber

Components:

- Mixer PCB with mixer motor for Viessmann mixer DN 20 to DN 50 and R ½ to R 1¼
- Flow temperature sensor (contact temperature sensor)
- Plug for connecting the heating circuit pump
- 3.0 m long power cable with plug
- BUS connecting cable (3.0 m long) with plug

The mixer motor is mounted directly onto the Viessmann mixer DN 20 to DN 50 and R ½ to R 1¼.

#### Mixer PCB with mixer motor

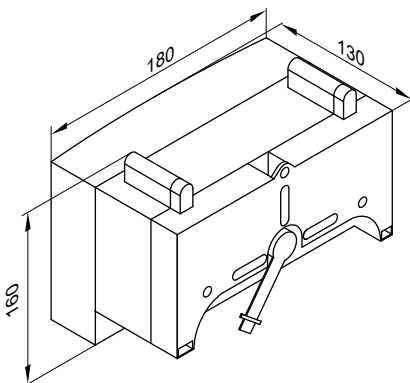

### Specification, mixer PCB with mixer motor

Rated voltage	230 V~
Rated frequency	50 Hz
Rated current	2 A
Power consumption	5.5 W
IP rating	IP 32D to EN 60529; ensure through design/installation
Safety category	I
Permissible ambient temperature	
– Operation	0 to +40 °C
– Storage and transport	–20 to +65 °C
Rated breaking capacity of the relay output for heating circuit pump 	2(1) A, 230 V~
Torque	3 Nm
Runtime for 90° <	120 s

### Flow temperature sensor (contact temperature sensor)

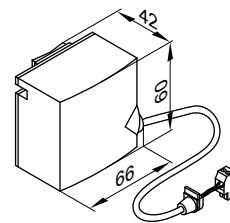

Secured with a tie.

### Specification, flow temperature sensor

Lead length	2.0 m, fully wired
IP rating	IP 32D to EN 60529; ensure through design/installation
Sensor type	Viessmann NTC 10 kΩ at 25 °C
Permissible ambient temperature	
– Operation	0 to +120 °C
– Storage and transport	–20 to +70 °C

## Control units (cont.)

### Mixer extension kit for separate mixer motor

#### Part no. ZK02941

KM BUS subscriber

For connecting a separate mixer motor

Components:

- Mixer PCB for connecting a separate mixer motor
- Flow temperature sensor (contact temperature sensor)
- Plug for connecting the heating circuit pump and the mixer motor
- 3.0 m long power cable with plug
- BUS connecting cable (3.0 m long) with plug

#### Mixer PCB

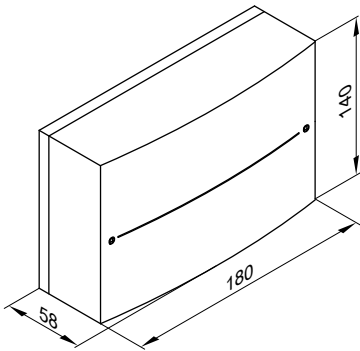

#### Specification, mixer PCB

Rated voltage	230 V~
Rated frequency	50 Hz
Rated current	2 A
Power consumption	1.5 W
IP rating	IP 20D to EN 60529, ensure through design/installation
Safety category	I

#### Permissible ambient temperature

- Operation 0 to +40 °C
- Storage and transport –20 to +65 °C

#### Rated relay output breaking capacity

- Heating circuit pump [20] 2(1) A, 230 V~
- Mixer motor 0.1 A, 230 V~

#### Required runtime of the mixer motor for 90° <

approx. 120 s

#### Flow temperature sensor (contact temperature sensor)

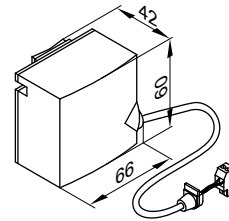

Secured with a tie.

#### Specification, flow temperature sensor

Lead length	5.8 m, fully wired
IP rating	IP 32D to EN 60529; ensure through design/installation
Sensor type	Viessmann NTC 10 kΩ at 25 °C
Permissible ambient temperature	
– Operation	0 to +120 °C
– Storage and transport	–20 to +70 °C

### Vitotronic 300-K extension for heating circuits 2 and 3 with mixer

#### Part no. 7164403

PCB for installation in the Vitotronic 300-K, type MW2B.

For controlling 2 heating circuits with mixer.

- With connections for mixer motors, flow temperature sensors (NTC 10 kΩ) and heating circuit pumps.
- Plug for mixer motor and heating circuit pump for each heating circuit.

### Mixer extension kit in conjunction with Divicon heating circuit distributor

#### Part no. 7424958

Components:

- Mixer PCB with mixer motor
- Flow temperature sensor NTC 10 kΩ (immersion temperature sensor for installation in the Divicon)
- Connection plug for heating circuit pump, power supply, flow temperature sensor and KM BUS connection

#### Mixer PCB

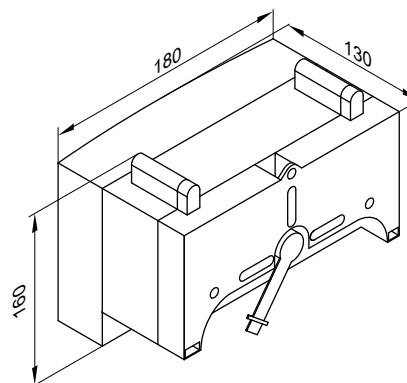

## Control units (cont.)

### Mixer PCB specification

Rated voltage	230 V~
Rated frequency	50 Hz
Rated current	2 A
Power consumption	5.5 W
IP rating	IP 32 D to EN 60529; ensure through design/installation.
Safety category	I
Permissible ambient temperature	
– Operation	0 to +40 °C
– Storage and transport	–20 to +65 °C
Rated relay output breaking capacity for heating circuit pump <sup>[20]</sup>	2(1) A, 230 V~
Runtime for 90° <	Approx. 120 s

### Flow temperature sensor (immersion temperature sensor)

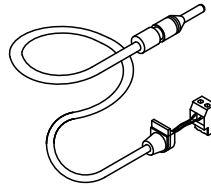

### Specification, flow temperature sensor

Lead length	0.9 m, fully wired
IP rating	IP 32 to EN 60529; ensure through design/installation.
Sensor type	Viessmann NTC 10 kΩ at 25 °C
Permissible ambient temperature	
– Operation	0 to +120 °C
– Storage and transport	–20 to +70 °C

## Extension kit for one heating circuit with mixer for Vitotronic 300-K

### Part no. 7441998

Components:

- Mixer motor
  - Flow temperature sensor (contact temperature sensor), lead length 5.8 m, fully wired
  - Plug for connecting the heating circuit pump
  - Terminals for connecting the mixer motor
  - Connecting cable (4.0 m long)
- The mixer motor is mounted directly onto the mixer DN 20 to 50 or R ½ to 1¼.

### Mixer motor

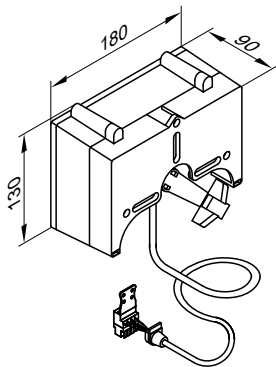

### Extension kit specification

Rated voltage	230 V~
Rated frequency	50 Hz
Power consumption	2.5 W
Protection class	I
IP rating	IP 32D to EN 60529; ensure through design/installation

Permissible ambient temperature	
– Operation	0 to +40 °C
– Storage and transport	–20 to +65 °C
Torque	3 Nm
Runtime for 90° <	120 s

### Flow temperature sensor (contact temperature sensor)

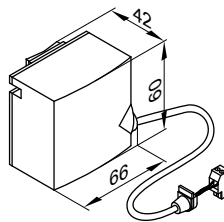

Secured with a tie.

### Specification

IP rating	IP 32D to EN 60529 Ensure through design/installation
Sensor type	Viessmann NTC 10 kΩ at 25 °C
Permissible ambient temperature	
– Operation	0 to +120 °C
– Storage and transport	–20 to +70 °C

### Mixer motors

See datasheet "Control unit accessories".

## Immersion temperature limiter

### Part no. 7151728

May be used as a maximum temperature limiter for underfloor heating systems.

The temperature limiter is fitted to the heating flow. If the flow temperature is too high, the temperature limiter switches off the heating circuit pump.

## Control units (cont.)

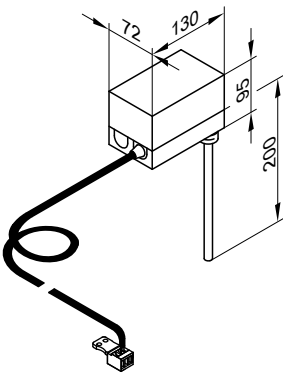

### Specification

Lead length	4.2 m, fully wired
Setting range	30 to 80 °C
Switching differential	Max. 11 K
Breaking capacity	6(1.5) A, 250 V~
Setting scale	Inside the enclosure
Stainless steel sensor well (male thread)	R ½ x 200 mm
DIN reg. no.	DIN TR 1168

## Contact temperature limiter

### Part no. 7151729

Can be used as a maximum temperature limiter for underfloor heating systems (only in conjunction with metal pipes). The temperature limiter is fitted to the heating flow. If the flow temperature is too high, the temperature limiter switches off the heating circuit pump.

### Specification

Lead length	4.2 m, fully wired
Setting range	30 to 80 °C
Switching differential	Max. 14 K
Breaking capacity	6(1.5) A, 250 V~
Setting scale	Inside the enclosure
DIN reg. no.	DIN TR 1168

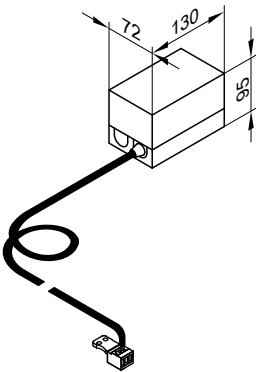

## Solar control module, type SM1

### Part no. Z014470

### Specification

#### Functions

- Output statement and diagnostic system
- Operation and display via the Viessmann control unit.
- Switching the solar circuit pump
- Heating of 2 consumers via a collector array
- 2nd temperature differential control
- Thermostat function for reheating or utilising excess heat
- Speed control for solar circuit pump via PWM input (make: Grundfos and Wilo)
- Suppression of DHW cylinder reheating by the heat generator subject to solar yield
- Heat-up of the solar preheating stage (with DHW cylinders from 400 l capacity)
- Collector safety shutdown
- Electronic temperature limitation in the DHW cylinder
- Switching of an additional pump or valve via relay

To implement the following functions, also order immersion temperature sensor, part no. 7438702:

- For DHW circulation changeover in systems with 2 DHW cylinders
- For return changeover between the heat generator and the heating water buffer cylinder

- For return changeover between the heat generator and the primary heat store
- For heating additional consumers

### Structure

The solar control module contains:

- PCB
- Terminals:
  - 4 sensors
  - Solar circuit pump
  - KM-BUS
  - Power supply (on-site ON/OFF switch)
- PWM output for switching the solar circuit pump
- 1 relay for switching one pump or one valve

### Collector temperature sensor

For connection inside the appliance

On-site extension of the connecting lead:

- 2-core lead, length up to 60 m with a cross-section of 1.5 mm<sup>2</sup> (copper)
- Do not route this lead immediately next to 230 V/400 V cables.

## Control units (cont.)

### Specification – collector temperature sensor

Lead length	2.5 m
IP rating	IP 32 to EN 60529; ensure through design/installation.
Sensor type	Viessmann NTC 20 kΩ at 25 °C
Permissible ambient temperature	
– Operation	–20 to +200 °C
– Storage and transport	–20 to +70 °C

### Cylinder temperature sensor

For connection inside the appliance

On-site extension of the connecting lead:

- 2-core lead, length up to 60 m with a cross-section of 1.5 mm<sup>2</sup> (copper)
- Never route this lead immediately next to 230/400 V cables.

### Specification – cylinder temperature sensor

Lead length	3.75 m
IP rating	IP 32 to EN 60529; ensure through design/installation.
Sensor type	Viessmann NTC 10 kΩ at 25 °C
Permissible ambient temperature	
– Operation	0 to +90 °C
– Storage and transport	–20 to +70 °C

For systems with Viessmann DHW cylinders, the cylinder temperature sensor is installed in the threaded elbow in the heating water return (standard delivery or accessory for the respective DHW cylinder).

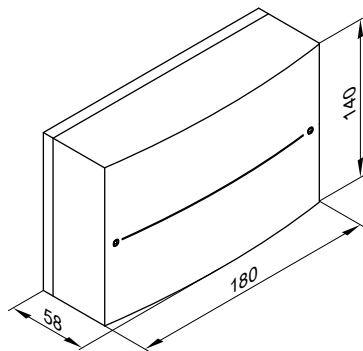

### Solar control module specification

Rated voltage	230 V~
Rated frequency	50 Hz
Rated current	2 A
Power consumption	1.5 W
Protection class	I
IP rating	IP 20 to EN 60529; ensure through design/installation.
Function type	Type 1B to EN 60730-1
Permissible ambient temperature	
– Operation	0 to +40 °C, for use in the living space or boiler room (standard ambient conditions)
– Storage and transport	–20 to +65 °C
Rated relay output breaking capacity	
– Semi-conductor relay 1	1 (1) A, 230 V~
– Relay 2	1 (1) A, 230 V~
– Total	Max. 2 A

5

## Internal H1 extension

Part no. 7498513

PCB for installation in the control unit.

The following functions can be achieved with the extension:

Function	Rated breaking capacity of the relay output
– Connection of an external safety solenoid valve (LPG)	1(0.5) A 250 V~
and <b>one</b> of the following functions:	2(1) A 250 V~
– Connection of a heating circuit pump for a directly connected heating circuit	
– Connection of a central fault message	
– Only for Vitotronic 200, type HO1B:	
– Connection of a DHW circulation pump	

### Power supply for DHW circulation pump

DHW circulation pumps equipped with their own internal control unit must be connected via a separate power supply. Power supply via the Vitotronic control unit or Vitotronic accessories is **not** permissible.

### Specification

Rated voltage	230 V~
Rated frequency	50 Hz

## Control units (cont.)

### Internal H2 extension

**Part no. 7498514**

PCB for installation in the control unit.

The following functions can be achieved with the extension:

Function	Rated breaking capacity of the relay output
– External extractor interlock	6(3) A 250 V~
and <b>one</b> of the following functions:	2(1) A 250 V~
– Connection of a heating circuit pump for a directly connected heating circuit	
– Connection of a central fault message	
– Only for Vitotronic 200, type HO1B:	
Connection of a DHW circulation pump	

#### Power supply for DHW circulation pump

DHW circulation pumps equipped with their own internal control unit must be connected via a separate power supply. Power supply via the Vitotronic control unit or Vitotronic accessories is **not** permissible.

#### Specification

Rated voltage	230 V~
Rated frequency	50 Hz

### AM1 extension

**Part no. 7452092**

Function extension inside enclosure for wall mounting.

Up to 2 of the following pumps can be controlled:

- DHW circulation pump with weather-compensated control unit
- Circulation pump for cylinder heating in conjunction with separate DHW cylinder
- Heating circuit pump for heating circuit without mixer

#### Power supply for DHW circulation pump

DHW circulation pumps equipped with their own internal control unit must be connected via a separate power supply. Power supply via the Vitotronic control unit or Vitotronic accessories is **not** permissible.

#### Specification

Rated voltage	230 V~
Rated frequency	50 Hz
Rated current	4 A
Power consumption	4 W
Rated relay output breaking capacity	2(1) A, 250 V~ each, total max. 4 A~
Safety category	I
IP rating	IP 20 D to EN 60529, ensure through design/installation
Permissible ambient temperature	
– Operation	0 to +40 °C Installation in living spaces or boiler rooms (standard ambient conditions)
– Storage and transport	–20 to +65 °C

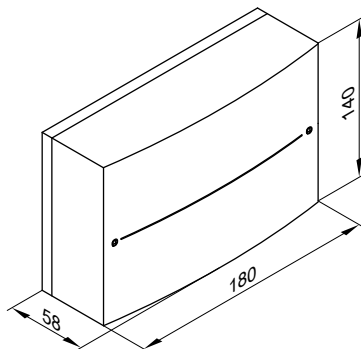

### EA1 extension

**Part no. 7452091**

Function extension inside enclosure for wall mounting.

Using the inputs and outputs allows up to 5 functions to be achieved:

- 1 switching output (floating changeover contact)
- Central fault message output (only with Vitotronic 100, type HC1B and Vitotronic 200, type HO1B)
- Feed pump connection to a substation
- Switching of DHW circulation pump (only with the Vitotronic 200, type HO1B)

1 analogue input (0 to 10 V)

- Specifying set boiler water temperature

3 digital inputs

- External operating program changeover for 1 to 3 heating circuits (only with Vitotronic 200, type HO1B, and Vitotronic 300-K, type MW2B)
- External blocking
- External blocking with central fault message
- Requirement for a minimum boiler water temperature
- Fault messages
- Short term operation of DHW circulation pump (only with Vitotronic 200, type HO1B, and Vitotronic 300-K, type MW2B)
- Signalling reduced operation for one heating circuit (only for Vitotronic 300-K, type MW2B)

## Control units (cont.)

### Power supply for DHW circulation pump

DHW circulation pumps equipped with their own internal control unit must be connected via a separate power supply. Power supply via the Vitotronic control unit or Vitotronic accessories is **not** permissible.

#### Note

Ensure DC separation between the negative pole and the earth conductor of the on-site voltage source (isolating amplifier ZK03695).

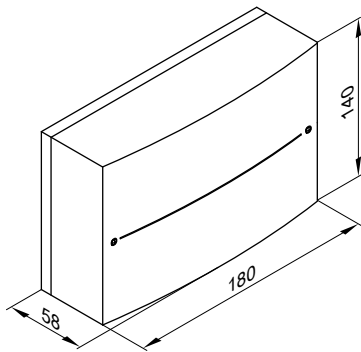

### Specification

Rated voltage	230 V~
Rated frequency	50 Hz
Rated current	2 A
Power consumption	4 W
Rated breaking capacity of the relay output	2(1) A, 250 V~
Safety category	I
IP rating	IP 20 D to EN 60529, ensure through design/installation
Permissible ambient temperature	
– Operation	0 to +40 °C Installation in living spaces or boiler rooms (standard ambient conditions)
– Storage and transport	–20 to +65 °C

## Vitocom 300, type LAN3

Part no.: See current pricelist

For remote monitoring, telecontrol and remote setting of heating systems via IP networks (LAN).

As an internet data transfer establishes a permanent connection ("always online"), access to the heating system is particularly fast.

For heating systems with one or more heat generators, with or without heating circuits downstream

For system operation with **Vitodata 300**

### Functions when operating with Vitodata 300

For all heating circuits in a heating system:

#### ■ Remote monitoring:

- Forwarding messages via SMS to mobile phone/smartphone, via email to end devices with email client functionality or via fax to fax machines
- Monitoring additional devices via the inputs and outputs of the Vitocom 300

#### ■ Remote control:

- Selecting operating programs, set values, time programs and heating curves
- Recording trends via datalogger
- Recording energy consumption through integration of M-Bus heat meters

#### ■ Remote setup:

- Configuring Vitocom 300 parameters
- Remote setup of Vitotronic control parameters via coding addresses

#### Note

- Alongside the data transfer telecommunication costs, usage charges have to be taken into account for Vitodata 300.
- Further information: See [www.vitodata.info](http://www.vitodata.info).

### Configuration

- In the case of dynamic IP addressing (DHCP), the IP configuration of the Vitocom 300 occurs automatically.  
No adjustments have to be made on the DSL router.
- Observe the network settings of the DSL router.

- The outputs and inputs of the Vitocom 300 and EM301 extension module are configured using the Vitodata 300 user interface.
- The Vitocom 300 is connected to the Vitotronic control unit via LON. The Vitocom 300 does not need to be configured for the LON.

### Fault messages

Fault messages are reported to the Vitodata server. These messages are transmitted via the following communication services from the Vitodata server to the configured recipients:

- Fax
- SMS to mobile phones
- Email to PC/laptop

### On-site requirements

- DSL router with free LAN socket and dynamic IP addressing (DHCP)
- Internet connection with flat rate data (**without** time or volume restrictions)
- LON communication module must be installed in the Vitotronic.

#### Note

Further information: See [www.vitocom.info](http://www.vitocom.info).

### Standard delivery

- Vitocom 300, type LAN3 with LAN socket
  - Mounting rail installation TS35 to EN 50022, 35 x 15 and 35 x 7.5
  - 2 digital inputs
  - 1 digital output
  - 1 relay output
  - 1 M-Bus interface
  - 1 EM interface
  - 2 LON connections
- LAN cable, RJ45, 2 m long
- LON communication module
- LON cable, RJ45 – RJ45, 7 m long, for data exchange between Vitotronic control unit and Vitocom 300



## Control units (cont.)

- Power supply unit for top-hat rail, mounting rail installation TS35 to EN 50022, 35 x 15 and 35 x 7.5
- Vitodata 100 fault management for a duration of 3 years

### Note

For standard delivery of packs with Vitocom, see pricelist.

### Accessories

Accessories	Part no.
<b>Wall mounting enclosure</b> for installation of the Vitocom 300 and accessories if no control panel or electrical distribution panel is available. 2 rows 3 rows	7143434 7143435
<b>EM301 extension module</b> – Mounting rail installation TS35 to EN 50022, 35 x 15 and 35 x 7.5. – 8 analogue inputs: – 0 – 10 V <sub>DC</sub> – 4 – 20 mA – Viessmann NTC 10 kΩ, NTC 20 kΩ, Ni500 or Pt500 temperature sensors – Pulse counter – 8 digital inputs: – For hooking up signals via floating contacts – 2-pole – Breaking capacity of the external contact 24 V <sub>DC</sub> , 7 mA – With LED indicator – N/C or N/O contact – N/C or N/O alarm contact – Pulse counter – 2 digital outputs: – Floating relay contacts – 3-pole changeover contact – Max. 2 A, 230 V~ – With LED indicator Max. 3 x EM301 extension modules per Vitocom 300	Z012117
<b>Uninterrupted power supply module (UPS)</b> Mounting rail installation TS35 to EN 50022, 35 x 15 and 35 x 7.5	7143432
<b>Additional rechargeable battery pack</b> for UPS – Mounting rail installation TS35 to EN 50022, 35 x 15 and 35 x 7.5 – <b>Recommended</b> with 1 Vitocom 300 and 1 extension module where all inputs are allocated – <b>Required</b> with 1 or more Vitocom 300 and 2 extension modules	7143436

Accessories	Part no.
<b>Connecting cable extension</b> <b>Installation spacing 7 to 14 m</b> – 1 connecting cable (7 m long) and 1 LON coupling RJ45 <b>Installation spacing 14 to 900 m</b> with plug-in connector – 2 LON plug-in connectors RJ45 and – 2-core cable, CAT5, screened, solid wire, AWG 26-22, 0.13 to 0.32 mm <sup>2</sup> , external diameter 4.5 to 8 mm or 2-core cable, CAT5, screened, stranded wire, AWG 26-22, 0.14 to 0.36 mm <sup>2</sup> , external diameter 4.5 to 8 mm.	7143495 and 7143496  7199251 and On site
<b>Installation spacing 14 to 900 m with socket</b> – 2 connecting cables (7 m long) and – 2 LON sockets RJ45, CAT6 – 2-core cable, CAT5, screened or JY(St) Y 2 x 2 x 0.8	7143495 and 7171784 On site

### Vitocom 300 specification (standard delivery)

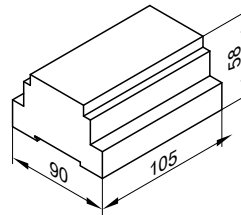

### Specification

Rated voltage	24 V <sub>DC</sub>
Rated current	710 mA
Rated output	17 W
Protection class	II to EN 61140
IP rating	IP 30 to EN 60529; ensure through design/installation
Function type	Type 1B to EN 60730- 1
Permissible ambient temperature	
– Operation	0 to +50 °C Installation in living spaces or installation rooms (standard ambient conditions)
– Storage and transport	–20 to +85 °C
On-site connections	
– 2 digital inputs DI1 and DI2	Floating contacts, contact breaking capacity 24 V <sub>DC</sub> , 7 mA, for monitoring additional devices and third party systems, with LED indicator
– 1 digital output DO	Relay, contact breaking capacity 24 V <sub>DC</sub> , max. 2 A, changeover contact
– 1 M-Bus interface	For connecting heat meters with M-Bus interface to EN 1434-3
– 1 EM interface	For connecting up to three EM301 extension modules, with LED indicator

## Control units (cont.)

### Specification, power supply unit (standard delivery):

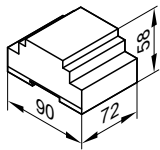

Rated voltage	100 to 240 V~
Rated frequency	50/60 Hz
Rated current	0.8 to 0.4 A
Output voltage	24 V=
Max. output current	2 A
Protection class	II to EN 61140
IP rating	IP 20 to EN 60529; ensure through design/installation
Primary/secondary galvanic isolation	SELV to EN 60950
Electrical safety	EN 60335
Permissible ambient temperature	
– Operation	–20 to +55 °C Installation in living spaces or installation rooms (standard ambient conditions)
– Storage and transport	–25 to +85 °C

### LON connecting cable for data exchange between control units

Vitotronic 300-K to Vitotronic 200-H

Cable length 7 m, fully wired.

Part no. 7143495

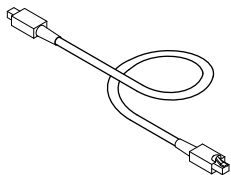

### Extension of the connecting cable

- Installation spacing 7 to 14 m:
  - 2 connecting cables (7.0 m long)  
**Part no. 7143495**
  - 1 LON coupling RJ45  
**Part no. 7143496**
- Installation spacing 14 to 900 m with plug-in connectors:
  - 2 LON plug-in connectors  
**Part no. 7199251**
  - 2-core cable:
    - CAT5, screened
    - or
    - Solid conductor AWG 26-22/0.13 mm<sup>2</sup> to 0.32 mm<sup>2</sup>, conductor AWG 26-22/0.14 mm<sup>2</sup> to 0.36 mm<sup>2</sup>
    - Ø 4.5 mm - 8 mm
    - on site**
- Installation spacing 14 to 900 m with junction boxes:
  - 2 connecting cables (7.0 m long)  
**Part no. 7143495**
  - 2-core cable:
    - CAT5, screened
    - or
    - Solid conductor AWG 26-22/0.13 mm<sup>2</sup> to 0.32 mm<sup>2</sup>, conductor AWG 26-22/0.14 mm<sup>2</sup> to 0.36 mm<sup>2</sup>
    - Ø 4.5 mm to 8 mm
    - on site**
  - 2 LON sockets RJ45, CAT6  
**Part no. 7171784**

### Terminators (2 pce)

Part no. 7143497

For terminating the LON at the first and last control unit.

### LON communication module

PCB for data exchange with the Vitotronic 200-H, Vitocom 200 and for connecting to higher level building management systems.

- For installation in Vitotronic 200  
**Part no. 7179113**
- For installation in Vitotronic 300-K  
**Part no. 7172174**

## Control units (cont.)

### Vitoconnect 100, type OPTO2

Part no. ZK04789

Part no. ZK04789

- Internet interface for remote control of a heating system with 1 heat generator via WiFi with DSL router
- Compact device for wall mounting
- For system operation with **ViCare app** and/or **ViGuide**

#### Functions when operating with the ViCare app

- Calling up the temperatures of connected heating circuits
- Intuitive adjustment of preferred temperatures and time programs for central heating and DHW heating
- Heating system fault reporting by push notification

The ViCare app supports mobile devices with the following operating systems:

- Apple iOS
- Google Android

#### Note

- *Compatible versions: Visit the App Store or Google Play.*
- *Further information: Visit [www.vicare.info](http://www.vicare.info)*

#### Functions when operating with ViGuide

- Monitoring of heating systems following service clearance by the system user
- Access to operating programs, set values and time programs
- Retrieving system information for all connected heating systems
- Display and forwarding of fault messages in plain text

#### Note

For further information: Visit [www.vitoguide.info](http://www.vitoguide.info)

#### On-site requirements

- Compatible heating systems with Vitoconnect, type OPTO2

#### Note

Supported control units: Visit [www.viessmann.de/vitoconnect](http://www.viessmann.de/vitoconnect)

- Before commissioning, check the system requirements for communication via local IP networks/WiFi.
- Port 443 (HTTPS) and port 123 (NTP) must be open.
- The MAC address is printed on the device label.
- Internet connection with flat rate data (**without time or volume restrictions**)

#### Installation location

- Installation type: Wall mounting
- Installation only in enclosed buildings
- The installation location must be dry and free of frost.
- Distance to heat generator min. 0.3 m and max. 2.5 m
- Socket 120 V/60 Hz  
max. 1.5 m to installation location
- Internet access with adequate WiFi signal

#### Note

The WiFi signal strength can be increased with commercially available WiFi repeaters.

#### Standard delivery

- Web interface for wall mounting
- Power cable with plug-in power supply unit (1.5 m long)
- Connecting cable with Optolink/USB (WiFi module/boiler control unit, 3 m long)

#### Specification

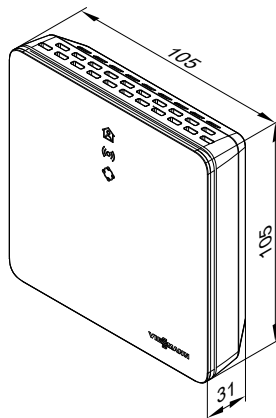

#### Vitoconnect specification

Rated voltage	12 V $\overline{=}$
WiFi frequency	2.4 GHz
WiFi encryption	Unencrypted or WPA2
Frequency band	2400.0 to 2483.5 MHz
Max. transmission power	0.1 W (e.i.r.p.)
Internet protocol	IPv4
IP assignment	DHCP
Rated current	0.5 A
Power consumption	5.5 W
Protection class	III
IP rating	IP 20D to EN 60529
Permissible ambient temperature	
– Operation	+5 to +40 °C Installation in living spaces or boiler rooms (standard ambient conditions)
– Storage and transport	–20 to +60 °C

#### Plug-in power supply unit specification

Rated voltage	100 to 240 V $\sim$
Rated frequency	50/60 Hz
Output voltage	12 V $\overline{=}$
Output current	1 A
Protection class	II
Permissible ambient temperature	
– Operation	+5 to +40 °C Installation in living spaces or boiler rooms (standard ambient conditions)
– Storage and transport	–20 to +60 °C

### 6.1 Regulations / Directives

#### Regulations and directives

We, Viessmann Climate Solutions SE, declare that the Vitodens gas condensing boilers have been tested and approved in accordance with the currently applicable directives/regulations, standards and technical rules.

Observe all engineering standards of the building authorities and statutory requirements applicable to the installation and operation of this system.

Installation, gas and flue gas connections, commissioning, electrical connections and general service/maintenance may only be carried out by a registered contractor.

The installation of a condensing boiler must be reported to and approved by the relevant gas supply utility.

In some regions, permits may be required for the flue system and condensate connection to the public waste water system.

The local flue gas inspector and water authorities must be informed prior to commencing installation.

We recommend that maintenance and cleaning procedures are performed annually. As part of the maintenance procedure, check the correct function of the entire system. Any faults that occur must be rectified.

Condensing boilers must only be operated with specially designed, tested and approved flues.

Only an authorised contractor may convert this boiler for use in countries other than those stated on the type plate. That contractor must also arrange approval in accordance with the statutes of the relevant country.

## Keyword index

<b>A</b>		<b>H</b>	
Accessories for Vitotronic.....	91	Hardness.....	81
AM1 extension.....	103	Heating curve adjustment.....	87
Anti-corrosion agents.....	81	Heat pumps.....	30, 34, 38
		Hydraulic connection.....	81
<b>B</b>		<b>I</b>	
Boiler water temperature sensor.....	85, 87	Immersion temperature limiter.....	100
		Installation room.....	54
<b>C</b>		Interlock circuit.....	54
Cables.....	58	Interlock switch.....	58
Carbon monoxide.....	54, 56	Internal H1 extension.....	102
Cascade control unit.....	88	Internal H2 extension.....	103
CO limiter.....	54, 56		
Combustion air supply.....	54	<b>K</b>	
Condensate.....	78	KM BUS distributor.....	98
Condensate connection.....	77		
Conductivity.....	81	<b>L</b>	
Connection accessories		Level.....	87
– Installation to left/right.....	29, 33, 37	LON communication module.....	106
– Installation to top/bottom.....	29, 33, 37	Low water indicator.....	81
– Wall mounting bracket for heating circuit connection set.....	30, 34, 38		
Connection sets		<b>M</b>	
– DHW cylinder.....	28, 32, 36	Magnetite.....	82
– For combination with CHP unit.....	29, 33, 37	Mixer extension	
– Heating circuit with high efficiency circulation pump for combination with external system separation or heating water buffer cylinder.....	32, 36	– Integral mixer motor.....	98, 99
– Heating circuit without circulation pump for combination with external system separation or heating water buffer cylinder.....	28	– Separate mixer motor.....	99
– Heating circuit with variable speed high efficiency circulation pump and low loss header.....	28, 32, 36	Mixer extension kit	
Constant temperature control		– Integral mixer motor.....	98, 99
– Functions.....	85	– Separate mixer motor.....	99
Constant temperature control unit		Mounting frame.....	30, 34, 38
– Frost protection function.....	85		
– Functions.....	84	<b>N</b>	
– Heating programs.....	85	Neutralisation.....	78
– Layout.....	84	Neutralising granulate.....	80
– Programming unit.....	84	Neutralising system.....	78, 79, 80
– Standard unit.....	84		
Contact temperature limiter.....	101	<b>O</b>	
Control unit		Open flue operation.....	54
– For constant temperature.....	84	Outside temperature sensor.....	87, 90
– For weather-compensated operation.....	85		
		<b>P</b>	
<b>D</b>		pH value.....	81, 82
Dirt separator.....	82	Pressure drop	
Dirt trap.....	82	– Divicon.....	44
Distributor with low loss header.....	84	Protection.....	56
Dual sensor well.....	30, 34, 38	Pump curves.....	42
<b>E</b>		<b>R</b>	
EA1 extension.....	103	Residual head.....	42
Electrical conductivity.....	82	Residual heads	
Electrical connection.....	57	– Divicon.....	47
Electrical safety zone.....	57	Room sealed operation.....	55
Expansion vessel.....	83	Room temperature controller.....	92, 93
Extension		Room temperature sensor.....	97
– Internal H1.....	102	Room thermostat.....	92, 93
– Internal H2.....	103		
<b>F</b>			
Fill water.....	81		
Flow rates, max./min.....	83		
Flushing water.....	82		
Frost protection.....	82		
Frost protection function.....	85, 86, 89		
<b>G</b>			
Gas connection.....	58		
GEG.....	86, 89		

## Keyword index

### S

Safety equipment.....	81
Safety valve.....	81
Safety zone, electrical.....	57
Separating facility.....	82
Siting conditions.....	54
Slope.....	87
Softening.....	82
Solar control module	
– Specification.....	102
Specification	
– Solar control module.....	101, 102
Specific system volume.....	82
Standard unit.....	85
System design.....	81

### T

Temperature limiter	
– Contact temperature.....	101
– Immersion temperature.....	100
Temperature sensor	
– Room temperature sensor.....	97
Temperature sensors	
– Boiler water temperature sensor.....	85, 87
– For low loss header.....	31, 35, 39
– Outside temperature sensor.....	87, 90
Thermally activated safety shut-off valve.....	58
Time program.....	89
Time switch.....	86
Top-up water.....	81

### V

VDI 2035.....	81, 82
Vitotrol	
– 200-A.....	94
– 200-RF.....	95
– 300-A.....	95
Vitotrol 100	
– UTA.....	92
– UTDB.....	92
– UTDB-RF.....	93

### W

Waste water system.....	82
Water hardness.....	81
Weather-compensated control	
– Frost protection function.....	86, 89
– Operating programs.....	86
Weather-compensated control unit	
– Design.....	85
– Functions.....	85, 86
– Programming unit.....	86
– Standard unit.....	85
Wet room.....	56
Wireless components	
– Wireless base station.....	96
– Wireless remote control.....	95
– Wireless repeater.....	96



Subject to technical modifications.

Viessmann Climate Solutions SE  
35108 Allendorf / Germany  
Telephone: +49 6452 70-0  
Fax: +49 6452 70-2780  
[www.viessmann.com](http://www.viessmann.com)

Viessmann Limited  
Hortonwood 30, Telford  
Shropshire, TF1 7YP, GB  
Telephone: +44 1952 675000  
Fax: +44 1952 675040  
E-mail: [info-uk@viessmann.com](mailto:info-uk@viessmann.com)

5822432