

Solenoid Valves

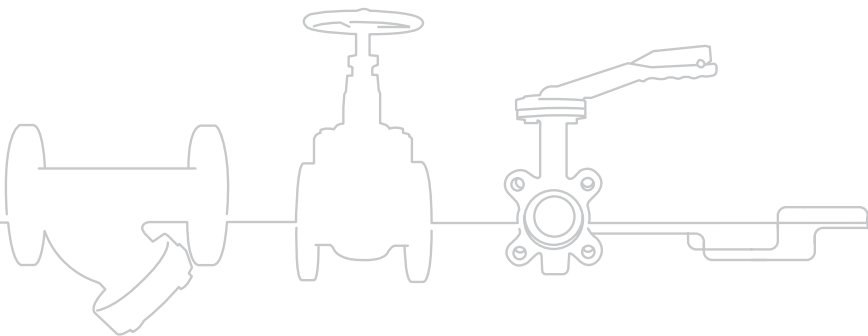

Product Information



SLP 2/2 WAY SOLENOID VALVE SERIES

A: Product Applications.

SLP 2/2 way series solenoid valves are commonly used actuators in automation control systems, which are widely used for automatic closing and opening of all kinds of fluids such as, water, hot water, gas, liquid, light oil, etc in pipework systems.

B: Operating Principles.

SLP 2/2 way series solenoid valves include normally closed type and normally open type.

For SLP 2/2 way series solenoid valves with orifice below $\varnothing 6\text{mm}$, the operation is direct-acting type.

For SLP 2/2 way series solenoid valves with orifice above $\varnothing 10\text{mm}$, the operation is pilot-operated type.

SLP direct-acting/normally closed/small orifice type valves close when de-energized. When the coil is energized, the armature will open against the spring force, the valve will then open and the media will flow. When the coil is de-energized, the armature will close under the force from the spring, the valve will then close and the flow of media will be stopped. SLP valves' operation is simple, and the action is reliable. Direct acting valves will operate with zero line pressure and even in very low vacuums. Please consult our technical department for advice on specific pressure/vacuum applications.

SLP pilot-operated/normally closed/large orifice type valves design is based on the combination of pilot valve and diaphragm operation. Normally closed type valves close when de-energized. When the coil is energized, the armature will open the pilot port, the differential pressure created allows the diaphragm to open and the media to flow. When the coil is de-energized, the armature will close under the force from the spring closing the pilot port and allowing the force from the main spring on the diaphragm to close the valve. The flow of the media will then be stopped.

SLP normally open type valves operating principle is the opposite to normally closed type.

ZS 2/2 WAY ZERO PRESSURE DIFFERENTIAL SOLENOID VALVE SERIES

A: Product Applications.

ZS 2/2 way series solenoid valves are commonly used actuators in automation control systems, which are widely used for automatic closing and opening of all kinds of fluids such as, water, hot water, gas, liquid, light oil, etc in pipework systems.

B: Operating Principles.

ZS 2/2 way series valves are Zero Pressure Differential/Direct acting series solenoid valves include normally closed type and normally open type.

For ZS 2/2 way series solenoid valves with orifice below $\varnothing 10\text{mm}$, the operation is direct-acting type.

For ZS 2/2 way series solenoid valves with orifice above $\varnothing 15\text{mm}$, the operation is sub-step direct-acting type.

ZS direct-acting/normally closed/small orifice type valves close when de-energized. When the coil is energized, the armature will open against the spring force, the valve will then open and the media will flow. When the coil is de-energized, the armature will close under the force from the spring, the valve will then close and the flow of media will be stopped. ZS valves' operation is simple, and the action is reliable. Direct acting valves will operate with zero line pressure and even in very low vacuums. Please consult our technical department for advice on specific pressure/vacuum applications.

ZS sub-step direct-acting/normally closed/large orifice type valves design is based on the combination of pilot valve and diaphragm operation. Normally closed type valves close when de-energized. When the coil is energized, the armature will open the pilot port, the differential pressure created allows the diaphragm to open and the media to flow. When the coil is de-energized, the armature will close under the force from the spring closing the pilot port and allowing the force from the main spring on the diaphragm to close the valve. The flow of the media will then be stopped.

ZS normally open type valves operating principle is the opposite to normally closed type.

THP 2/2 WAY STEAM, WATER, LIQUID, GAS, VALVE SERIES

A: Product Applications.

THP 2/2 way series solenoid valves are commonly used actuators in automation control systems, which are widely used for automatic closing and opening of all kinds of fluids such as, water, hot water, steam, gas, liquid, light oil, etc in pipework systems.

B: Operating Principles.

THP 2/2 way series solenoid valves include normally closed type and normally open type.

For THP 2/2 way series solenoid valves with orifice below Ø6mm, the operation is direct-acting type.

For THP 2/2 way series solenoid valves with orifice above Ø10mm, the operation is pilot-operated type.

THP direct-acting/normally closed/small orifice type valves close when de-energized. When the coil is energized, the armature will open against the spring force, the valve will then open and the media will flow. When the coil is de-energized, the armature will close under the force from the spring, the valve will then close and the flow of media will be stopped. THP valves' operation is simple, and the action is reliable. Direct acting valves will operate with zero line pressure and even in very low vacuums. Please consult our technical department for advice on specific pressure/vacuum applications.

THP pilot-operated/normally closed/large orifice type valves design is based on the combination of pilot valve and main piston operation. Normally closed type valves close when de-energized. When the coil is energized, the armature will open the pilot port, the differential pressure created allows the piston to open and the media to flow. When the coil is de-energized, the armature will close under the force from the spring closing the pilot port and allowing the force from the main spring on the piston to close the valve. The flow of the media will then be stopped.

THP normally open type valves operating principle is the opposite to normally closed type.

Seal Materials

Medium \ Material	Suitability					
	NBR	EPDM	Silicon	Viton	PTFE	
Highest Working Temperature	80°C	120°C	180°C	120°C	175°C	
Lowest Working Temperature	-5°C	-20°C	-40°C	-20°C	-50°C	
Steam	x	v	g	n	g	
Oil	v	x	n	v	v	
General Chemical Resistance	n	v	v	v	v	
General Acid Resistance	n	v	n	v	v	
General Alkalinity Resistance	g	v	n	v	v	
Water	g	v	g	g	v	

Key: v-very good g-good n-normal x-not suitable

Part Numbers

How to construct a part number

Valve Series	Port Size	Seal Material	Voltage	Orifice Size	Body Material	Control Style	Coil Type
SLP	06:1/8"	Blank:NBR	E1:AC110V	1L:1.0	Blank:Brass		Blank: DIN Connector
ZS	08:1/4"	V:VITON	E2:AC230V	1.5L:1.5	S1:SS316	Blank: Normal Close	F: Flying Leads
THP	10:3/8"	E:EPDM	E3:AC380V	2.5L:2.5	S2:SS304	H:Normal Open	
	15:1/2"	G:Silicon Rubber	E4:DC24V	3L:3.0			
	20:3/4"	T:Teflon	E5:DC12V	4L:4.0			
	25:1"		E6:AC36V	5L:5.0			
	35:1.1/4"		E7:AC24V	6L:6.0			
	40:1.1/2"		E8:DC110V	10L:10.0			
	50:2"		E9:DC48V	10.5L:10.5			
	F:Flange		E10:DC36V	13L:13			
				15L:15			
				20L:20	Cancel if same as port size		
				25L:25	Cancel if same as port size		
				35L:35	Cancel if same as port size		
				40L:40	Cancel if same as port size		
				50L:50	Cancel if same as port size		
				65L:65			
				80L:80			
				100L:100			

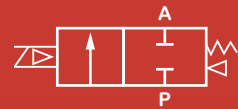

Parts Diagram

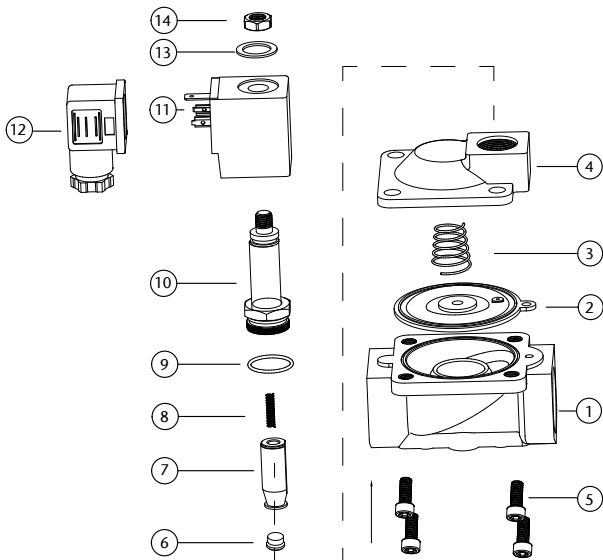

N.	Component	Material
1	Valve Body	Brass/Stainless Steel 316
2	Diaphragm	NBR/EPDM/Viton
3	Diaphragm Spring	Stainless Steel 304
4	Valve Cover	Brass/Stainless Steel 316
5	Bolt	Stainless Steel 302
6	Pilot Seal	NBR/EPDM/Viton
7	Pilot	Stainless Steel 1J117
8	Pilot Spring	Stainless Steel 304
9	O Ring	NBR/EPDM/Viton
10	Plunger Tube Unit	Stainless Steel 304 + 1J117
11	Coil	Enamelled Wire
12	Plug	Nylon
13	Washer	Stainless Steel 302
14	Lock Nut	Stainless Steel 302

Available in 230VAC, 110VAC
12VDC, 24VDC, 24VAC

Thread standard: ISO 228/1

Main Dimensions

Orifice: 3mm & 4mm
Port: 1/8", 1/4" & 3/8"

Orifice: 10.5mm
Port: 1/4", 3/8" & 1/2"

Large Orifice
See Table opposite

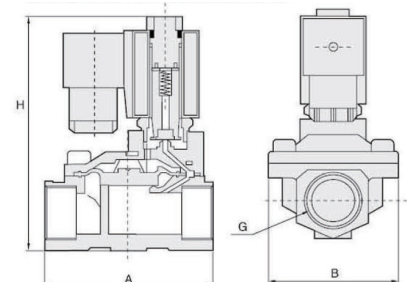
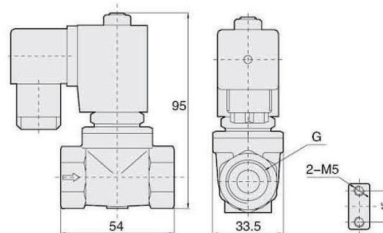
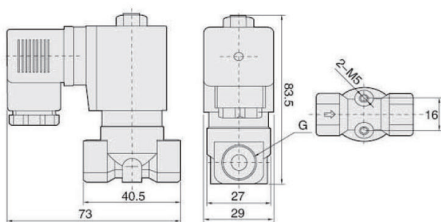

2/2 Solenoid Valve Normally Closed

Valve Specification

Port Size (G)	Orifice	CV Value	Pressure Difference (Bar)				Max. Temp. (°C)	VA AC 230V	W DC 24V	Diaphragm	Main Dimension
			Min.	Max. Working Pressure							
				Air / Gas	Water / Hot Liquid	Light Oil ≤20CST					AxBxH
1/8"	3	0.23	0	13	13	10	80	22	13	NBR	-
	3	0.23	0	13	13	-	120	22	13	EPDM	-
	3	0.23	0	13	13	10	120	22	13	VITON	-
1/4"	3	0.23	0	13	13	10	80	22	13	NBR	-
	3	0.23	0	13	13	-	120	22	13	EPDM	-
	3	0.23	0	13	13	10	120	22	13	VITON	-
	10.5	1.47	0	16	16	13	80	22	13	NBR	-
	10.5	1.47	0	16	16	-	120	22	13	EPDM	-
	10.5	1.47	0	16	16	13	120	22	13	VITON	-
3/8"	3	0.3	0	13	13	10	80	22	13	NBR	-
	3	0.3	0	13	13	10	120	22	13	EPDM	-
	3	0.3	0	13	13	10	120	22	13	VITON	-
	4	0.6	0	8	8	6	80	22	13	NBR	-
	4	0.6	0	8	8	6	120	22	13	EPDM	-
	4	0.6	0	8	8	6	120	22	13	VITON	-
	10.5	1.68	0	16	16	13	80	22	13	NBR	-
	10.5	1.68	0	16	16	-	120	22	13	EPDM	-
	10.5	1.68	0	16	16	13	120	22	13	VITON	-
	13	4.5	0.5	16	16	13	80	22	13	NBR	66x48x112
	13	4.5	0.5	16	16	-	120	22	13	EPDM	66x48x112
	13	4.5	0.5	16	16	13	120	22	13	VITON	66x48x112
1/2"	10.5	1.75	0	16	16	13	80	22	13	NBR	-
	10.5	1.75	0	16	16	-	120	22	13	EPDM	-
	10.5	1.75	0	16	16	13	120	22	13	VITON	-
	13	4.5	0.5	16	16	13	80	22	13	NBR	66x48x112
	13	4.5	0.5	16	16	-	120	22	13	EPDM	66x48x112
	13	4.5	0.5	16	16	13	120	22	13	VITON	66x48x112
3/4"	20	7.6	0.5	16	16	13	80	22	13	NBR	75x58x118
	20	7.6	0.5	16	16	-	120	22	13	EPDM	75x58x118
	20	7.6	0.5	16	16	13	120	22	13	VITON	75x58x118
1"	25	12	0.5	16	16	13	80	22	13	NBR	96x70x131
	25	12	0.5	16	16	-	120	22	13	EPDM	96x70x131
	25	12	0.5	16	16	13	120	22	13	VITON	96x70x131
1.1/4"	35	22	0.5	16	16	13	80	22	13	NBR	131x96x146
	35	22	0.5	16	16	-	120	22	13	EPDM	131x96x146
	35	22	0.5	16	16	13	120	22	13	VITON	131x96x146
1.1/2"	40	30	0.5	16	16	13	80	22	13	NBR	131x96x146
	40	30	0.5	16	16	-	120	22	13	EPDM	131x96x146
	40	30	0.5	16	16	13	120	22	13	VITON	131x96x146
2"	50	48	0.5	16	16	13	80	22	13	NBR	165x120x167
	50	48	0.5	16	16	-	120	22	13	EPDM	165x120x167
	50	48	0.5	16	16	13	120	22	13	VITON	165x120x167
1" Flange Connection	25	12	0.5	16	16	13	80	22	13	NBR	134x110x160
	25	12	0.5	16	16	-	120	22	13	EPDM	134x110x160
	25	12	0.5	16	16	13	120	22	13	VITON	134x110x160
1.1/4" Flange Connection	35	22	0.5	16	16	13	80	22	13	NBR	160x135x175
	35	22	0.5	16	16	-	120	22	13	EPDM	160x135x175
	35	22	0.5	16	16	13	120	22	13	VITON	160x135x175
1.1/2" Flange Connection	40	30	0.5	16	16	13	80	22	13	NBR	160x145x180
	40	30	0.5	16	16	-	120	22	13	EPDM	160x145x180
	40	30	0.5	16	16	13	120	22	13	VITON	160x145x180
2" Flange Connection	50	48	0.5	12	12	13	80	22	13	NBR	200x160x207
	50	48	0.5	12	12	-	120	22	13	EPDM	200x160x207
	50	48	0.5	12	12	13	120	22	13	VITON	200x160x207
2.1/2" Flange Connection	65	52	0.5	12	12	8	80	33	20	NBR	250x185x250
	65	52	0.5	12	12	-	120	33	20	EPDM	250x185x250
	65	52	0.5	12	12	8	120	33	20	VITON	250x185x250
3" Flange Connection	80	80	0.5	12	12	8	80	33	20	NBR	270x202x262
	80	80	0.5	12	12	-	120	33	20	EPDM	270x202x262
	80	80	0.5	12	12	8	120	33	20	VITON	270x202x262
4" Flange Connection	100	128	0.5	12	12	8	80	33	20	NBR	342x222x287
	100	128	0.5	12	12	-	120	33	20	EPDM	342x222x287

Please refer to our price list for stocked items

Dimensions in mm

This data sheet is designed as a guide and should not be regarded as wholly accurate in every detail. We reserve the right to amend the specification of any product without notice.

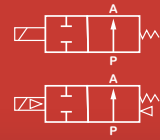

Parts Diagram

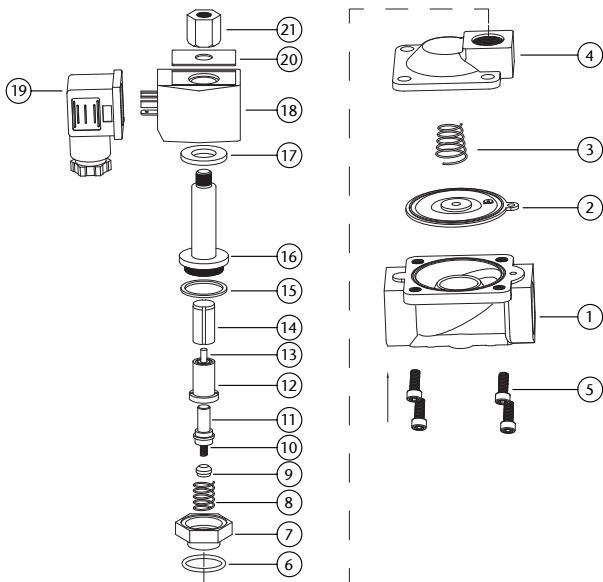

N.	Component	Material
1	Valve Body	Brass/Stainless Steel 316
2	Diaphragm	NBR/EPDM/Viton
3	Diaphragm Spring	Stainless Steel 304
4	Valve Cover	Brass/Stainless Steel 316
5	Bolt	Stainless Steel 302
6	O Ring	NBR/EPDM/Viton
7	Midbody	Brass/Stainless Steel 316
8	Spring	Stainless Steel 304
9	Mandril Seal	NBR/EPDM/Viton
10	Spring	Stainless Steel 304
11	Mandril	Stainless Steel 304
12	Fixed Amature	Stainless Steel 1J117
13	Pole	Stainless Steel 304
14	Moving Amature	Stainless Steel 1J117
15	Plunger Tube Seal	PTFE
16	Plunger Tube Unit	Stainless Steel 304 + 1J117
17	Baseplate	Plated Steel
18	Coil	Enamelled Wire
19	Plug	Nylon
20	Plate	Aluminium
21	Lock Nut	Stainless Steel 302

Available in 230VAC, 110VAC
12VDC, 24VDC, 24VAC

Thread standard: ISO 228/1

Main Dimensions

Orifice: 1mm to 2.5mm
Port: 1/8" & 1/4"

Orifice: 3mm
Port: 1/8" & 1/4"

Large Orifice
See Table Opposite

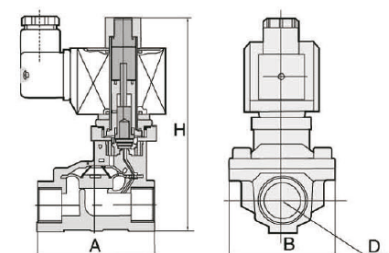
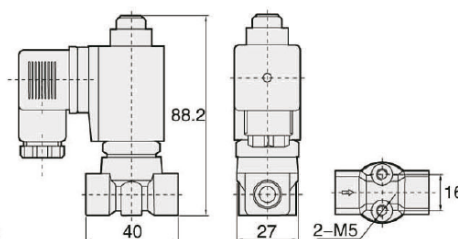
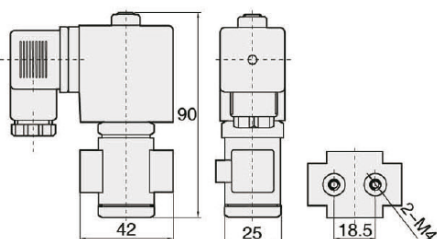

2/2 Solenoid Valve Normally Open

Valve Specification

Port Size (G)	Orifice	CV Value	Pressure Difference (Bar)				Max. Temp. (°C)	VA AC 230V	W DC 24V	Diaphragm	Main Dimension
			Min.	Max. Working Pressure							AxBxH
				Air / Gas	Water / Hot Liquid	Light Oil ≤20CST					
1/8"	1	0.04	0	30	30	25	80	22	13	NBR	
	1	0.04	0	30	30	-	120	22	13	EPDM	
	1	0.04	0	30	30	25	120	22	13	VITON	
	1.5	0.09	0	20	20	15	80	22	13	NBR	
	1.5	0.09	0	20	20	-	120	22	13	EPDM	
	1.5	0.09	0	20	20	15	120	22	13	VITON	
	2.5	0.2	0	15	15	12	80	22	13	NBR	
	2.5	0.2	0	15	15	-	120	22	13	EPDM	
	2.5	0.2	0	15	15	12	120	22	13	VITON	
	3	0.25	0	12	12	10	80	22	13	NBR	
	3	0.25	0	12	12	-	120	22	13	EPDM	
	3	0.25	0	12	12	10	120	22	13	VITON	
1/4"	1	0.04	0	30	30	25	80	22	13	NBR	
	1	0.04	0	30	30	-	120	22	13	EPDM	
	1	0.04	0	30	30	25	120	22	13	VITON	
	1.5	0.09	0	20	20	15	80	22	13	NBR	
	1.5	0.09	0	20	20	-	120	22	13	EPDM	
	1.5	0.09	0	20	20	15	120	22	13	VITON	
	2.5	0.2	0	15	15	12	80	22	13	NBR	
	2.5	0.2	0	15	15	-	120	22	13	EPDM	
	2.5	0.2	0	15	15	12	120	22	13	VITON	
	3	0.25	0	12	12	10	80	22	13	NBR	
	3	0.25	0	12	12	-	120	22	13	EPDM	
	3	0.25	0	12	12	10	120	22	13	VITON	
3/8"	13	4.5	0.5	8	8	7	80	33	32	NBR	66x48x124
	13	4.5	0.5	8	8		120	33	32	EPDM	66x48x124
	13	4.5	0.5	8	8	7	120	33	32	VITON	66x48x124
1/2"	13	4.5	0.5	8	8	7	80	33	32	NBR	66x48x124
	13	4.5	0.5	8	8		120	33	32	EPDM	66x48x124
	13	4.5	0.5	8	8	7	120	33	32	VITON	66x48x124
3/4"	20	7.6	0.5	8	8	7	80	33	32	NBR	75x58x130
	20	7.6	0.5	8	8		120	33	32	EPDM	75x58x130
	20	7.6	0.5	8	8	7	120	33	32	VITON	75x58x130
1"	25	12	0.5	8	8	7	80	33	32	NBR	96x70x143
	25	12	0.5	8	8		120	33	32	EPDM	96x70x143
	25	12	0.5	8	8	7	120	33	32	VITON	96x70x143
1.1/4"	35	22	0.5	8	8	7	80	33	32	NBR	131x96x158
	35	22	0.5	8	8		120	33	32	EPDM	131x96x158
	35	22	0.5	8	8	7	120	33	32	VITON	131x96x158
1.1/2"	40	30	0.5	8	8	7	80	33	32	NBR	131x96x158
	40	30	0.5	8	8		120	33	32	EPDM	131x96x158
	40	30	0.5	8	8	7	120	33	32	VITON	131x96x158
2"	50	48	0.5	8	8	7	80	33	32	NBR	165x120x179
	50	48	0.5	8	8		120	33	32	EPDM	165x120x179
	50	48	0.5	8	8	7	120	33	32	VITON	165x120x179
1" Flange Connection	25	12	0.5	8	8	7	80	33	32	NBR	134x110x172
	25	12	0.5	8	8		120	33	32	EPDM	134x110x172
	25	12	0.5	8	8	7	120	33	32	VITON	134x110x172
1.1/4" Flange Connection	35	22	0.5	8	8	7	80	33	32	NBR	160x135x187
	35	22	0.5	8	8		120	33	32	EPDM	160x135x187
	35	22	0.5	8	8	7	120	33	32	VITON	160x135x187
1.1/2" Flange Connection	40	30	0.5	8	8	7	80	33	32	NBR	160x145x192
	40	30	0.5	8	8		120	33	32	EPDM	160x145x192
	40	30	0.5	8	8	7	120	33	32	VITON	160x145x192
2" Flange Connection	50	48	0.5	8	8	7	80	33	32	NBR	200x160x219
	50	48	0.5	8	8		120	33	32	EPDM	200x160x219
	50	48	0.5	8	8	7	120	33	32	VITON	200x160x219

Please refer to our price list for stocked items

Dimensions in mm

This data sheet is designed as a guide and should not be regarded as wholly accurate in every detail. We reserve the right to amend the specification of any product without notice.

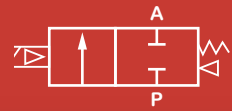

Parts Diagram

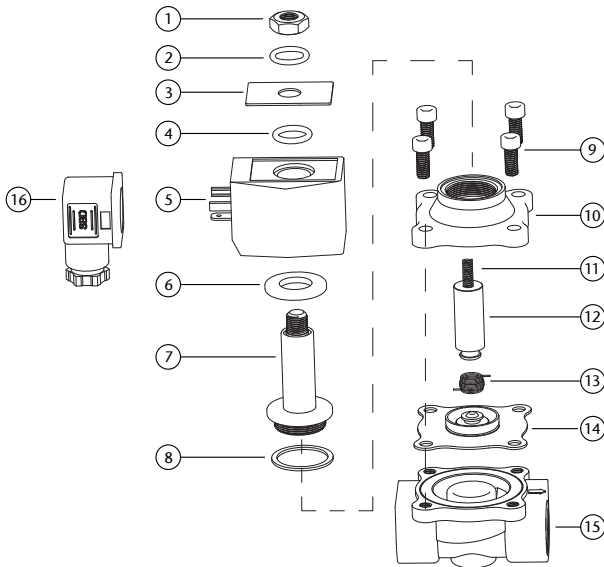

N.	Component	Material
1	Lock Nut	Stainless Steel 302
2	Washer	Stainless Steel 302
3	Plate	Aluminium
4	O Ring	NBR/EPDM/Viton
5	Coil	Enamelled Wire
6	Baseplate	Plated Steel
7	Plunger Tube Unit	Stainless Steel 304 +1J117
8	Plunger Tube Seal	PTFE
9	Bolt	Stainless Steel 302
10	Valve Cover	Brass/Stainless Steel 316
11	Plunger Spring	Stainless Steel 304
12	Pilot Unit	Stainless Steel 304 +1J117
13	Coil Spring	Stainless Steel 304
14	Diaphragm Unit	NBR/EPDM/Viton
15	Valve Body	Brass/Stainless Steel 316
16	Plug	Nylon

Available in 230VAC, 110VAC
12VDC, 24VDC, 24VAC

Thread standard: ISO 228/1

Main Dimensions

Orifice: 2.5mm - Port: 1/8" & 1/4"

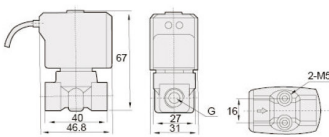

Orifice: 2.5mm - Port: 1/8" & 1/4"

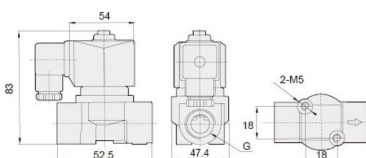

Orifice: 10mm - Port: 1/4", 3/8, 1/2"

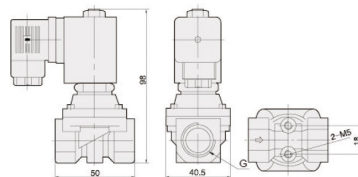

Large Orifice - See Table Opposite

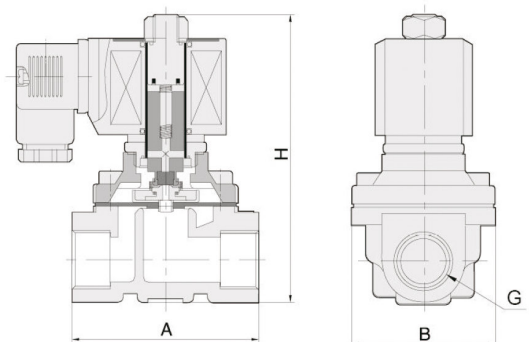

2/2 Solenoid Valve Normally Closed

Valve Specification

Port Size (G)	Orifice	CV Value	Pressure Difference (Bar)							Max. Temp. (°C)	VA AC 230V	W DC 24V	Diaphragm	Main Dimension
			Min.	Max. Working Pressure										AxBxH
				Air / Gas		Water / Hot Liquid		Light Oil ≤20CST						
				AC	DC	AC	DC	AC	DC					
1/8"	2.5	0.23	0	7	5	7	5	7	5	80	13	8.5	NBR	
	2.5	0.23	0	7	5	7	5	-	-	120	13	8.5	EPDM	
	2.5	0.23	0	7	5	7	5	7	5	120	13	8.5	VITON	
1/4"	2.5	0.23	0	7	5	7	5	7	5	80	13	8.5	NBR	
	2.5	0.23	0	7	5	7	5	-	-	120	13	8.5	EPDM	
	2.5	0.23	0	7	5	7	5	7	5	120	13	8.5	VITON	
	10	1	0	20	16	20	16	20	16	80	22	13	NBR	
	10	1	0	20	16	20	16	-	-	120	22	13	EPDM	
	10	1	0	20	16	20	16	20	16	120	22	13	VITON	
3/8"	4	0.6		8	5	8	5	5	5	80	33	20	NBR	
	4	0.6	0	8	5	8	5	-	-	120	33	20	EPDM	
	4	0.6	0	8	5	8	5	5	5	120	33	20	VITON	
	10	1.8	0	20	16	20	16	20	16	80	22	13	NBR	
	10	1.8	0	20	16	20	16	-	-	120	22	13	EPDM	
	10	1.8	0	20	16	20	16	20	16	120	22	13	VITON	
	16	4.8	0	10	6	10	6	7	4	80	33	20	NBR	
	16	4.8	0	10	6	10	6			120	33	20	EPDM	
	16	4.8	0	10	6	10	6	7	4	120	33	20	VITON	
1/2"	10	1.9	0	20	16	20	16	20	16	80	22	13	NBR	
	10	1.9	0	20	16	20	16	-	-	120	22	13	EPDM	
	10	1.9	0	20	16	20	16	20	16	120	22	13	VITON	
	16	4.8	0	10	6	10	6	7	4	80	33	20	NBR	
	16	4.8	0	10	6	10	6			120	33	20	EPDM	
	16	4.8	0	10	6	10	6	7	4	120	33	20	VITON	
3/4"	20	7.6	0	10	6	10	6	7	4	80	33	20	NBR	73x57x114
	20	7.6	0	10	6	10	6			120	33	20	EPDM	73x57x114
	20	7.6	0	10	6	10	6	7	4	120	33	20	VITON	73x57x114
1"	25	12	0	10	6	10	6	7	4	80	33	20	NBR	99x77x121
	25	12	0	10	6	10	6			120	33	20	EPDM	99x77x121
	25	12	0	10	6	10	6	7	4	120	33	20	VITON	99x77x121
	25	12	0	10	6	3	3			120	33	20	Silicon Rubber	99x77x121
1.1/4"	35	24	0	10	6	10	6	7	4	80	70	40	NBR	112x86.5x150
	35	24	0	10	6	10				120	70	40	EPDM	112x86.5x150
	35	24	0	10	6	10	6	7	4	120	70	40	VITON	112x86.5x150
1.1/2"	40	29	0	10	6	10	6	7	4	80	70	40	NBR	123x94x160
	40	29	0	10	6	10				120	70	40	EPDM	123x94x160
	40	29	0	10	6	10	6	7	7	120	70	40	VITON	123x94x160
2"	50	48	0	10	6	10	6	7	4	80	70	40	NBR	168x123x183
	50	48	0	10	6	10				120	70	40	EPDM	168x123x183
	50	48	0	10	6	10	6	7	4	120	70	40	VITON	168x123x183
1" Flange Connection	25	12	0	10	6	10	6	7	4	80	70	40	NBR	140x115x160
	25	12	0	10	6	10				120	70	40	EPDM	140x115x160
	25	12	0	10	6	10	6	7	4	120	70	40	VITON	140x115x160
1.1/4" Flange Connection	32	24	0	10	6	10	6	7	4	80	70	40	NBR	152x135x215
	32	24	0	10	6	10				120	70	40	EPDM	152x135x215
	32	24	0	10	6	10	6	7	4	120	70	40	VITON	152x135x215
1.1/2" Flange Connection	40	29	0	10	6	10	6	7	4	80	70	40	NBR	152x135x215
	40	29	0	10	6	10				120	70	40	EPDM	152x135x215
	40	29	0	10	6	10	6	7	4	120	70	40	VITON	152x135x215
2" Flange Connection	50	48	0	10	6	10	6	7	4	80	70	40	NBR	195x160x220
	50	48	0	10	6	10	6			120	70	40	EPDM	195x160x220
	50	48	0	10	6	10	6	7	4	120	70	40	VITON	195x160x220
2.1/2" Flange Connection	65	75	0	6	5	6	5	3	2	80	55	64	NBR	250x185x308
	65	75	0	6	5	6	5			120	55	64	EPDM	250x185x308
	65	75	0	6	5	6	5	3	2	120	55	64	VITON	250x185x308
3" Flange Connection	80	90	0	6	5	6	5	3	2	80	55	64	NBR	270x202x320
	80	90	0	6	5	6	5			120	55	64	EPDM	270x202x320
	80	90	0	6	5	6	5	3	2	120	55	64	VITON	270x202x320
4" Flange Connection	100	160	0	6	5	6	5	3	2	80	55	64	NBR	342x222x345
	100	160	0	6	5	6	5			120	55	64	EPDM	342x222x345
	100	160	0	6	5	6	5	3	2	120	55	64	VITON	342x222x345

Please refer to our price list for stocked items

Dimensions in mm

This data sheet is designed as a guide and should not be regarded as wholly accurate in every detail. We reserve the right to amend the specification of any product without notice.

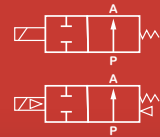

Parts Diagram

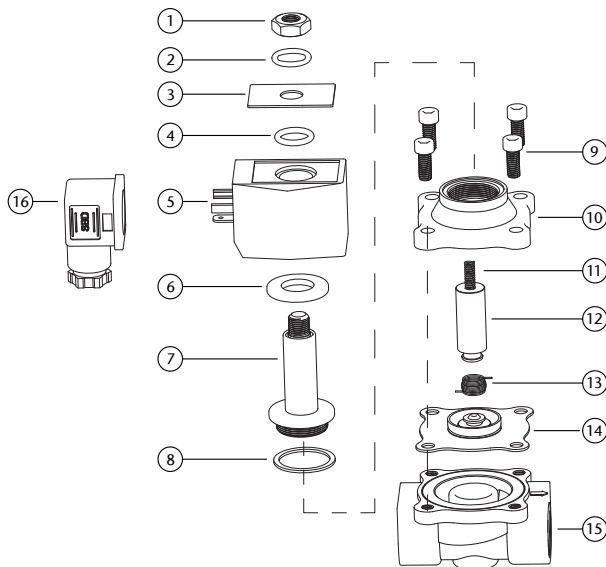

N.	Component	Material
1	Lock Nut	Stainless Steel 302
2	Washer	Stainless Steel 302
3	Plate	Aluminium
4	O Ring	NBR/EPDM/Viton
5	Coil	Enamelled Wire
6	Baseplate	Plated Steel
7	Plunger Tube Unit	Stainless Steel 304 +1J117
8	Plunger Tube Seal	PTFE
9	Bolt	Stainless Steel 302
10	Valve Cover	Brass/Stainless Steel 316
11	Plunger Spring	Stainless Steel 304
12	Pilot Unit	Stainless Steel 304 +1J117
13	Coil Spring	Stainless Steel 304
14	Diaphragm Unit	NBR/EPDM/Viton
15	Valve Body	Brass/Stainless Steel 316
16	Plug	Nylon

Available in 230VAC, 110VAC
12VDC, 24VDC, 24VAC

Thread standard: ISO 228/1

Main Dimensions

See Table Opposite

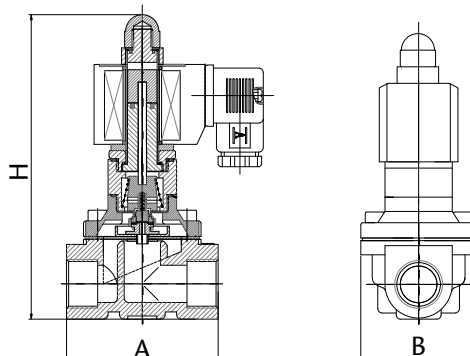

2/2 Solenoid Valve Normally Open

Valve Specification

Port Size (G)	Orifice	CV Value	Pressure Difference (Bar)							Max. Temp. (°C)	VA AC 230V	W DC 24V	Diaphragm	Main Dimension
			Min.	Max. Working Pressure										AxBxH
				Air / Gas			Water / Hot Liquid		Light Oil ≤20CST					
				AC	DC	AC	DC	AC	DC					
3/8"	4	0.6	0	5	3	5	3	3	3	80	57	32	NBR	52.5x32.5x115
	4	0.6	0	5	3	5	3			120	57	32	EPDM	52.5x32.5x115
	4	0.6	0	5	3	5	3	3	3	120	57	32	VITON	52.5x32.5x115
16	16	4.8	0	5	3	3	5	3	3	80	57	32	NBR	69x57x135
	16	4.8	0	5	3	3	5			120	57	32	EPDM	69x57x135
	16	4.8	0	5	3	3	5	3	3	120	57	32	VITON	69x57x135
1/2"	16	4.8	0	5	3	5	3	3	3	80	57	32	NBR	69x57x135
	16	4.8	0	5	3	5	3			120	57	32	EPDM	69x57x135
	16	4.8	0	5	3	5	3	3	3	120	57	32	VITON	69x57x135
3/4"	20	7.6	0	5	3	5	3	3	3	80	57.2	32	NBR	73x57x142
	20	7.6	0	5	3	5	3			120	57.2	32	EPDM	73x57x142
	20	7.6	0	5	3	5	3	3	3	120	57.2	32	VITON	73x57x142
1"	25	12	0	5	3	5	3	3	3	80	57.2	32	NBR	99x77.5x150
	25	12	0	5	3	5	3			120	57.2	32	EPDM	99x77.5x150
	25	12	0	5	3	5	3	3	3	120	57.2	32	VITON	99x77.5x150
1.1/4"	32	24	0	5	3	5	3	3	3	80	70	40	NBR	112x86.5x180
	32	24	0	5	3	5	3			120	70	40	EPDM	112x86.5x180
	32	24	0	5	3	5	3	3	3	120	70	40	VITON	112x86.5x180
1.1/2"	40	29	0	5	3	5	3	3	3	80	70	40	NBR	123x94x190
	40	29	0	5	3	5	3			120	70	40	EPDM	123x94x190
	40	29	0	5	3	5	3	3	3	120	70	40	VITON	123x94x190
2"	50	48	0	5	3	5	3	3	3	80	70	40	NBR	168x123x216
	50	48	0	5	3	5	3			120	70	40	EPDM	168x123x216
	50	48	0	5	3	5	3	3	3	120	70	40	VITON	168x123x216
1" Flange Connection	25	12	0	5	3	5	3	3	3	80	57	32	NBR	140x115x180
	25	12	0	5	3	5	3			120	57	32	EPDM	140x115x180
	25	12	0	5	3	5	3	3	3	120	57	32	VITON	140x115x180
1.1/4" Flange Connection	32	24	0	5	3	5	3	3	3	80	70	40	NBR	152x135x235
	32	24	0	5	3	5	3			120	70	40	EPDM	152x135x235
	32	24	0	5	3	5	3	3	3	120	70	40	VITON	152x135x235
1.1/2" Flange Connection	40	29	0	5	3	5	3	3	3	80	70	40	NBR	152x145x240
	40	29	0	5	3	5	3			120	70	40	EPDM	152x145x240
	40	29	0	5	3	5	3	3	3	120	70	40	VITON	152x145x240
2" Flange Connection	50	48	0	5	3	5	3	3	3	80	70	40	NBR	195x160x255
	50	48	0	5	3	5	3			120	70	40	EPDM	195x160x255
	50	48	0	5	3	5	3	3	3	120	70	40	VITON	195x160x255

Please refer to our price list for stocked items

Dimensions in mm

This data sheet is designed as a guide and should not be regarded as wholly accurate in every detail. We reserve the right to amend the specification of any product without notice.



Parts Diagram

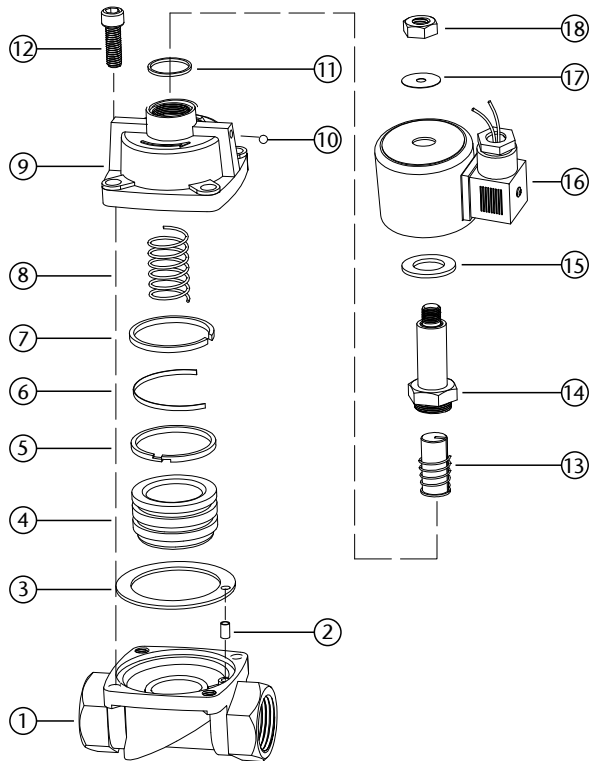

N.	Component	Material
1	Valve Body	Brass/Stainless Steel 316
2	Pin	Stainless Steel 304
3	Seal	PTFE
4	Piston unit	Stainless Steel 316
5	Piston Ring 1	PTFE
6	Elastic Ring	Spring Steel
7	Piston Ring 1	PTFE
8	Piston Spring	Stainless Steel 304
9	Valve Cover	Brass/Stainless Steel 316
10	Bolt	Brass/Stainless Steel 304
11	Plunger Tube Seal	PTFE
12	Bolt	Stainless Steel 302
13	Pilot Unit	Stainless Steel 1J117
14	Plunger Tube Unit	Stainless Steel 304 +1J117
15	Baseplate	Plated Steel
16	Coil	Enamelled Wire
17	Washer	Plated Steel
18	Lock Nut	Stainless Steel 302

Available in 230VAC, 110VAC
12VDC, 24VDC, 24VAC

Thread standard: ISO 228/1

Main Dimensions

See Table Opposite

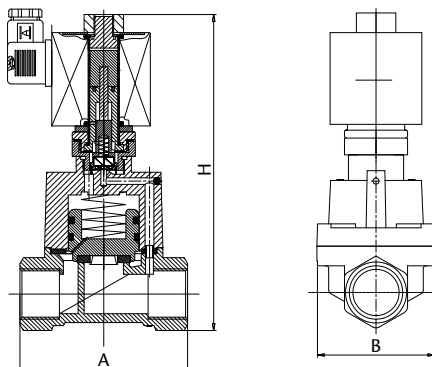

2/2 Solenoid Valve Normally Closed

Valve Specification

Port Size (G)	Orifice	CV Value	Pressure Difference (Bar)								Max. Temp. (°C)	VA	W	Diaphragm	Main Dimension
			Min.	Max. Working Pressure				Steam AC/DC	AxBxH						
				Air / Gas		Water / Hot Liquid				Light Oil ≤20CST					
AC	DC	AC	DC	AC	DC	AC	DC	AC/DC							
1/8"	2.5	0.23	0	8	8	8	8	6	6	8	175	22	13	PTFE	48x25x85.5
	2.5	0.23	0	13	13	13	13	7	7	10	110	22	13	VITON	48x25x85.5
	4.5	0.6	0	7	4	7	4	4	4	7	165	22	13	PTFE	58x25x85.5
	4.5	0.6	0	7	4	7	4	4	4	7	110	22	13	VITON	58x25x85.5
1/4"	2.5	0.23	0	7	4	7	4	4	4	8	175	22	13	PTFE	48x25x85.5
	2.5	0.23	0	13	13	13	13	7	7	10	110	22	13	VITON	48x25x85.5
	4.5	0.6	0	7	4	7	4	4	4	7	165	22	13	PTFE	58x25x85.5
	4.5	0.6	0	7	4	7	4	4	4	7	110	22	13	VITON	58x25x85.5
3/8"	15	4.5	0.5	25	20	25	20	20	20	8	175	30	25	PTFE	75x52x129
1/2"	15	4.5	0.5	25	20	25	20	20	20	8	175	30	25	PTFE	75x52x129
3/4"	20	9	0.5	25	20	25	20	20	20	8	175	30	25	PTFE	85x60x141
1"	25	13	0.5	25	20	25	20	20	20	8	175	30	25	PTFE	100x70x148
1.1/4"	35	26	0.5	25	20	25	20	20	20	8	175	30	25	PTFE	120x90x168
1.1/2"	35	26	0.5	25	20	25	20	20	20	8	175	30	25	PTFE	120x90x168
2"	50	48	0.5	25	20	25	20	20	20	8	175	30	25	PTFE	150x110x190
1" Flange	25	13	0.5	25	20	25	20	20	20	8	175	30	25	PTFE	134x110x185
1.1/4" Flange	35	26	0.5	25	20	25	20	20	20	8	175	30	25	PTFE	160x135x200
1.1/2" Flange	35	26	0.5	25	20	25	20	20	20	8	175	30	25	PTFE	160x145x205
2" Flange	50	45	0.5	25	20	25	20	20	20	8	175	30	25	PTFE	200x155x250

Please refer to our price list for stocked items

Dimensions in mm

This data sheet is designed as a guide and should not be regarded as wholly accurate in every detail. We reserve the right to amend the specification of any product without notice.



Universal Direct Mount Namur Solenoid

Features

- Life Cycle 12,000,000 operations
- 5/2 - 3/2 Interchangeable
- Available in 110VAC, 230VAC, 24VAC, 24VDC
- IP65
- Manual over-ride control

5/2 way (Double Acting Actuators)

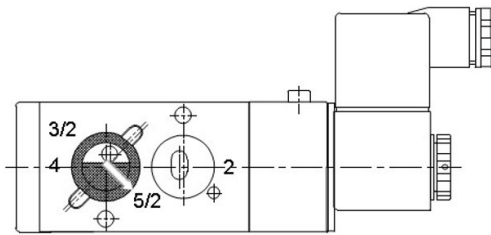

Model: V523231E4-08MG 5/2
5/2 way with silencers function diagram

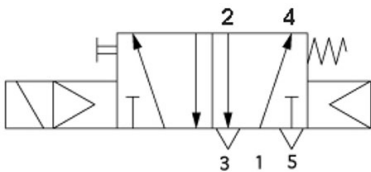

3/2 way (Spring Return Actuators)

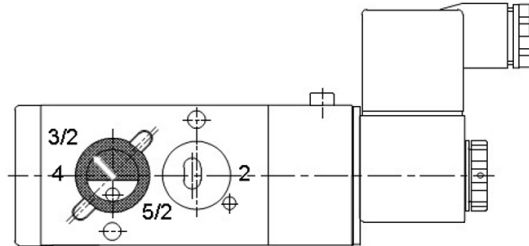

Model: V523231E4-08MG 3/2
3/2 way with silencers function diagram

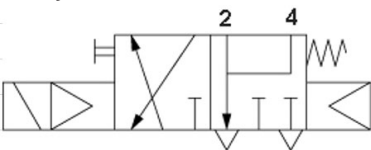

Technical Data

Working Pressure 1.5 to 8 Bar
Max Working Temperature -20°C to 60°C

Dimensions in mm

This data sheet is designed as a guide and should not be regarded as wholly accurate in every detail. We reserve the right to amend the specification of any product without notice.

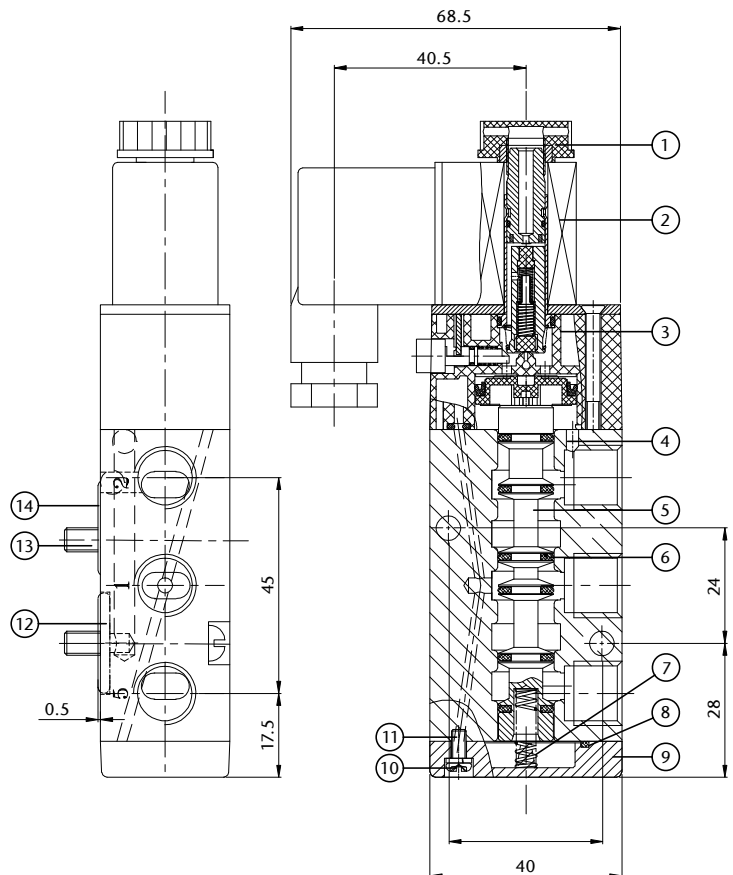

N.	Component	Material
1	Nut	PA66 (Nylon) + 30% GF (Plastic)
2	Coil (Din Plug)	Enamelled Wire & Engineering Plastic
3	Pilot Unit	Pure Steel & Cu & Stainless Steel
4	Valve Body	6061-T6 (Aluminum Alloy)
5	Spool	6061-T6 (Aluminum Alloy)
6	Flat Ring	HNBR 80°
7	Spring	SUS304-WPB
8	Diamond Ring	NBR
9	Rear Cover	Zinc Zlloy
10	Screw	Q235 (Steel)
11	Spring Washer	Q235 (Steel)
12	Switch Gasket	NBR & Q235
13	Screw	Q235 (Steel)
14	O Ring	NBR

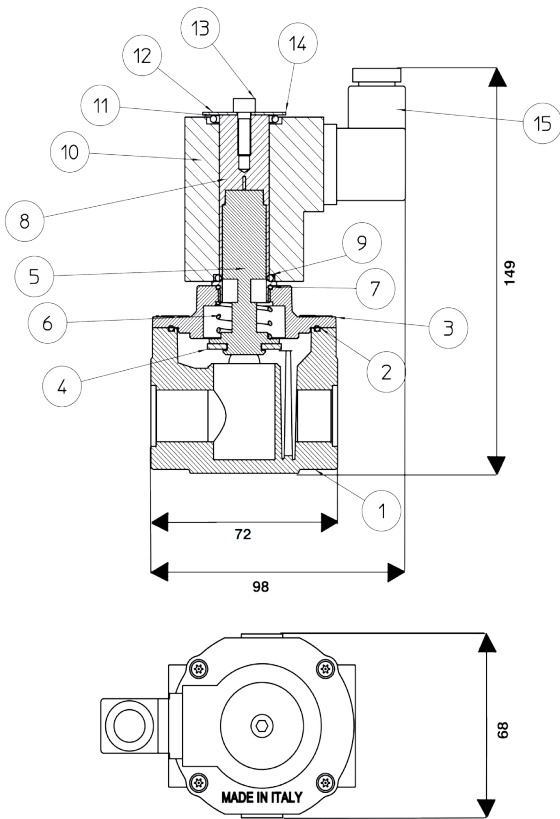

Automatic Gas Valves

Features

- BSP ISO 228
- Gas family 123 and air
- Approved to EN161
- Complies with PED 2014/68/EU
- Other voltages available on request
- Fail safe closed
- Automatic reset

Technical Features

Opening time	<1 second
Closing time	<1 second
Max number of operations	20 per minute
Supply Voltage	230V (-15%+10%) 50-60Hz
Power	15 VA Coils to class F copper wire class H
Test point	3 connections Screw 1/4" NPT
Protection degree	IP65
Weight	1/2" - 0.8kg 3/4" - 0.8kgs 1" - 0.8kgs

N.	Component	Material
1	Body	Aluminium Alloy
2	O-Ring	NBR
3	Cover	Aluminium Alloy
4	Gasket	NBR
5	Plunger	Steel - Brass
6	Spring	Stainless Steel 304
7	O-Ring	NBR
8	Pilot	Steel - Brass
9	O-Ring	NBR
10	Coil	Steel - Nylon - Copper
11	O-Ring	NBR
12	Washer	NBR
13	Screw	Steel
14	Washer	Stainless Steel
15	Connector	Nylon

Technical Data

Max Pressure	360 mbar
Working Temperature	-20°C to 60°C

Dimensions in mm

This data sheet is designed as a guide and should not be regarded as wholly accurate in every detail. We reserve the right to amend the specification of any product without notice.

Automatic Gas Valves

Features

- BSP ISO 228
- Gas family 123 and air
- Approved to EN161
- Complies with PED 2014/68/EU
- Fail safe closed
- Automatic reset

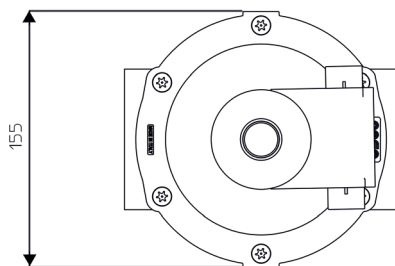
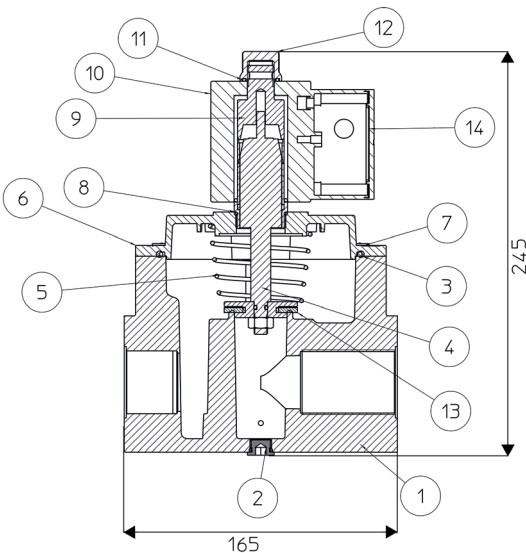

Technical Data

Max Pressure	360 mbar
Working Temperature	-20°C to 60°C

Dimensions in mm

This data sheet is designed as a guide and should not be regarded as wholly accurate in every detail. We reserve the right to amend the specification of any product without notice.

Technical Features

Opening time	<1 second
Closing time	<1 second
Max number of operations	20 per minute
Supply Voltage	230V (-15%+10%) 50-60Hz
Power	37W Coils to class F copper wire class H
Test point	5 connections Screw 1/4" NPT
Protection degree	IP65
Weight	1 1/4" - 4kgs 1 1/2" - 4kgs 2" - 4.6kgs

N.	Component	Material
1	Body	Aluminium Alloy
2	Screw Plugs	Aluminium Alloy
3	O-Ring	NBR
4	Plunger	Steel - Brass
5	Spring	Stainless Steel
6	Cover	Aluminium Alloy
7	Screw	Steel
8	O-Ring	NBR
9	Pilot	Steel Brass
10	Coil	Steel - Nylon - Copper
11	O-Ring	NBR
12	Locking Ring	Aluminium Alloy
13	Gasket	NBR
14	Connector	Nylon

Automatic Gas Valves

Features

- Flanged PN16
- Gas family 123 and air
- Approved to EN161
- Complies with PED 2014/68/EU
- Other voltages available on request
- Fail safe closed
- Automatic reset

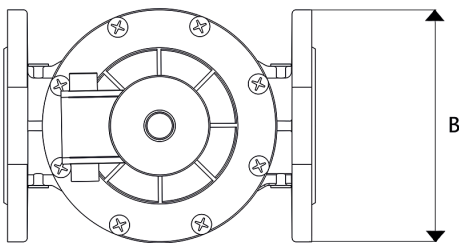
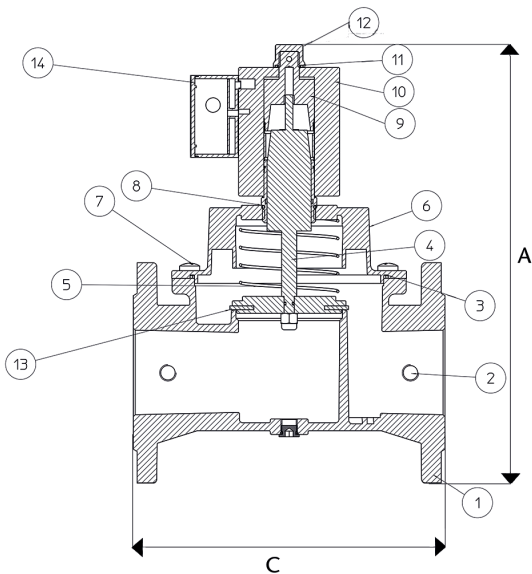

Technical Data

Max Pressure	360 mbar
Working Temperature	-20°C to 60°C

Dimensions in mm

This data sheet is designed as a guide and should not be regarded as wholly accurate in every detail. We reserve the right to amend the specification of any product without notice.

Technical Features

Opening time	<1 second
Closing time	<1 second
Max number of operations	15 per minute
Incorporated AISI 303 steel mesh filter	
Supply Voltage	230V (-15%+10%) 50-60Hz
Power	230Vac DN65 - DN80 - DN100 Peak power 400W Maintain power 4W Coils to class F copper wire class H
Test point	5 connections Screw ¼" NPT
Protection degree	IP65
Weight	2½" - 9.6kgs 3" - 9.6kgs 4" - 15.8kgs

DN	2½"	3"	4"
A	350	350	385
B	185	200	225
C	247	247	265

N.	Component	Material
1	Body	Aluminium Alloy
2	Screw Plugs	Aluminium Alloy
3	O-Rings	NBR
4	Plunger	Steel - Aluminium
5	Spring	Stainless Steel
6	Cover	Aluminium Steel
7	Screw	Steel
8	O-Ring	NBR
9	Pilo	Steel - Brass
10	Coil	Steel - Copper - Nylon
11	O-Ring	NBR
12	Locking Ring	Aluminium Alloy
13	Gasket	NBR
14	Connector	Nylon

PUT Timer

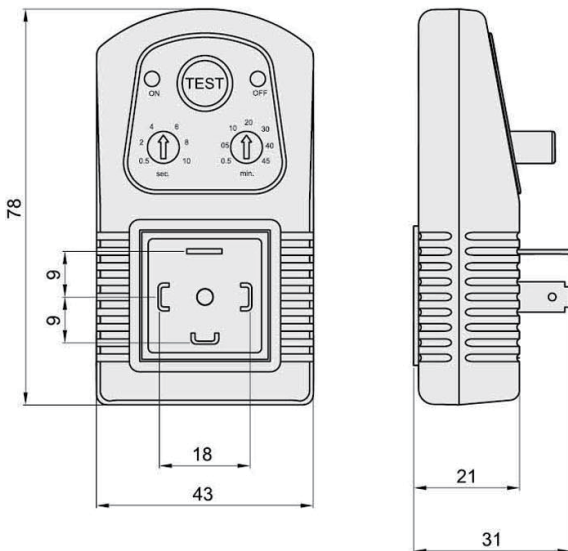

Features

- Used to control Albion's range of solenoid valves.
- Range 0.5 to 10 seconds on, 30 seconds to 45 mins off.
- LED light to indicate timing

Coils & Plugs

COIL - SLPC



24, 110, 230VAC
12, 24VDC

Orifice: 14.7
L x W x H
38.5x29x42mm

COIL - SLP-HC



Type A
24VDC
110, 230VAC
Type B
12VDC
24VAC

Orifice: 16.3
L x W x H
54x38.5x40mm

COIL - ZSC-2D



Type A
110, 230VAC

Orifice: Ø20.3
63OD x 50mm

Type B
24VAC, 12, 24VDC

Orifice: Ø20.3
73OD x 50mm

COIL - THP-C



24, 110, 230VAC
24VDC

Orifice: Ø16.3
50OD x 41mm

PLUG - NAMUR SOLENOID

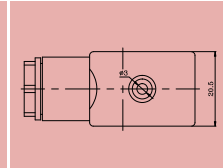
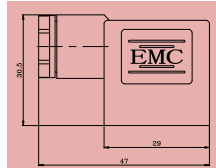

PLUG - SLP/ZS RANGES

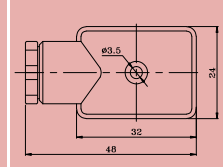
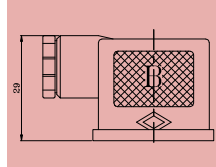

PLUG - THP RANGE

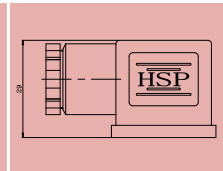
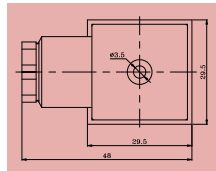

Dimensions in mm

This data sheet is designed as a guide and should not be regarded as wholly accurate in every detail. We reserve the right to amend the specification of any product without notice.

AVION



URS is a member of Registrar of Standards (Holdings) Ltd.
Certificate No. 1437B



URS is a member of Registrar of Standards (Holdings) Ltd.
Certificate No. 1437A

Distributor