

ELYSATOR^E
engineering water

IWTM

PROTECTOR MINI 2022



WWW.ELYSATOR.CO.UK

T: +44 208 255 2903

E: INFO@ELYSATORUK.COM

TABLE OF CONTENTS

03 PROTECTOR MINI DESCRIPTION

05 PROTECTOR MINI FUNCTIONS

06 FILTERING ELEMENTS

07 DETAILED INTERNAL AND
EXTERNAL VIEW

08 DIMENSIONS

10 TECHNICAL DATA



PROTECTOR MINI DESCRIPTION

ALL-IN-ONE FILTRATION AND WATER TREATMENT UNIT.

WHAT IS IT?

The Protector Mini is a product from our Marine partner IWTM.

Protector Mini is a unique side stream filtration device that engineers the system water to a non-corrosive state. It provides corrosion protection in both new and existing heating and cooling systems, by removing sludge, particles, oxygen, and other corrosive products. Therefore, the system is maintained in the best possible way, by constantly filtering and engineering the water using electrochemistry and anode technology. The result is that its cleaning and engineering the water at the same time.

Each filter contains neodymium magnets to retain ferrous particles, magnesium anodes to consume oxygen and increase the pH value, and a stainless-steel filter element (55µm) or bag filter (various micron sizes, down to 1 µm) to filtrate the water and remove any suspended solids. The two filter types are entirely interchangeable.

Protector Mini is completely insulated and cladded to prevent heat loss and condensation: it is installed as a side stream device only.

HOW DOES IT WORK?

The water enters from the inlet connection, then passes around and down, past magnets and anodes. During this process, oxygen will be consumed by dissolving the anodes, and excess air will rise up and out of the vent valve.

The water will now flow through the filter element / filter bag so that particles will physically be stopped by either of the filters. The result will be clear water with controlled alkaline pH, without oxygen or particles and sludge.

MAINTENANCE

When the progressive build-up of suspended solids retained by the stainless-steel screen causes an excessive increase of pressure differential between the inlet and outlet connections, the screen must be cleaned.

To perform the cleaning operations, there are two options either a normal backflush of the filter, or by complete removal and washing of the filter. The filter can be used to remove chemicals and, inhibitors but works well with organic glycol.

FIXING SYSTEMS

EASILY INSTALL THE PROTECTOR MINI ON THE WALL

Protector Mini has a compact wall fixing system; therefore the unit can be fixed on to the wall to save space in situations where space is important and limited. The system is included as a standard feature in the Protector Mini.

The wall fixing bracket and nuts are completely in stainless steel, very robust and resistant.

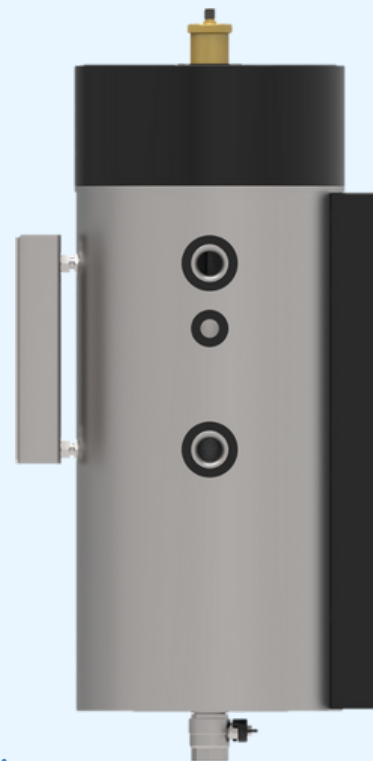

1) Wall Mounting bracket:

Protector Mini can be installed on the wall as of this stainless-steel wall bracket.

2) Cylindrical head screws & nuts: used to fix the Protector Mini



OPTIONAL FLOOR MOUNT SYSTEM

When wall space is not available, the Protector Mini can be fixed with the floor mount bracket as an alternative.

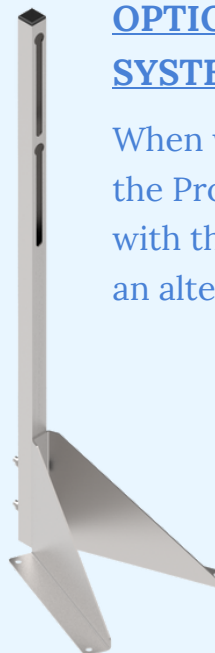

PROTECTOR MINI FUNCTIONS

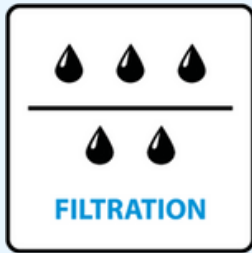

PARTICLE
FILTRATION



MAGNETIC
PROTECTION



REDUCES
DISSOLVED OXYGEN



CORROSION
PREVENTION

Prevents Corrosion

Protector's water treatment features prevent corrosion in the system. This is achieved thanks to magnesium anodes that lower oxygen, regulate pH, and reduce electrical conductivity.

All In One

Protector is an "all in one solution". It combines several different technologies in one single extremely functional and reliable device.

Traps Ferrous Particles

Protector is equipped with Neodymium Magnets that trap ferrous particles, drastically increasing the time before manual intervention is needed.

Removes Contamination

Protector cleans and restores recirculating systems by removing suspended particles.

+ PROVIDES	- REPLACES
Sludge and particle removal	Bag filters
Magnetite Removal	Magnet filters
pH adjustment	Chemicals
Oxygen consumption	Air separators
Cathodic / anodic water treatment	Dosing pots + automatic dosing systems

PROTECTOR FUNCTIONS

FILTERING ELEMENTS

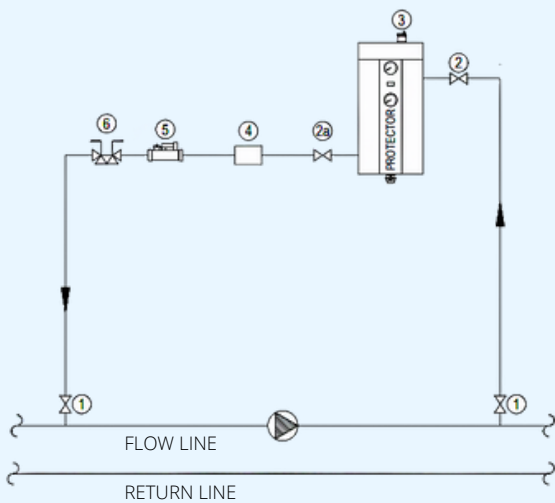

Protector Mini keeps your system clean by adapting to your needs. Two different filtering elements, completely interchangeable, remove suspended particles from the recirculating system.

The use of gauge filters by progressive stepped filtration helps to avoid filters blocking too early.

PARTICLE FILTRATION

Protector Mini comes as standard with a robust stainless steel filter which is 40 micron nominal (55 absolute). Stainless steel AISI 316, 55µm filter.

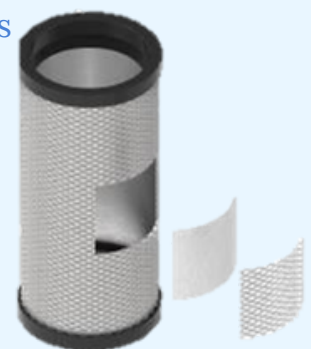

2-Layer S.S Filter

The filter has a large surface which gives a long operating time before cleaning and thus less flushing and refilling.



FINE FILTRATION

The filter elements can be replaced with filter bags with a filter degree down to 1 µm.

DETAILED EXTERNAL & INTERNAL VIEW



- 1 Vent pipe + automatic vent valve:** An automatic vent valve is installed at the top of the vent pipe.
- 2 Top insulation cap:** Easily removed when the Protector unit needs maintenance.
- 3 Inlet Pressure Gauge:** Stainless Steel pressure gauge that measures the inlet pressure. Scale 0-10 bar.
- 4 Vessel insulation and cladding:** External cladding in stainless steel and internal Armaflex insulation against cold/hot to prevent condensation.
- 5 Amp meter:** this indicator device measures the intensity of the current produced by the anode relative to the cathode, which is directly related to the corrosiveness of the system water.
- 6 Amp meter button:** tests operation of the swing meter.
- 7 Outlet Pressure Gauge:** Stainless Steel pressure gauge that measures the outlet pressure. Scale 0-10 bar.

8 Drain: The filter is emptied with a manual valve installed on the drainpipe. Can be easily connected to any existing drain manifold / pipe or automatic drain.

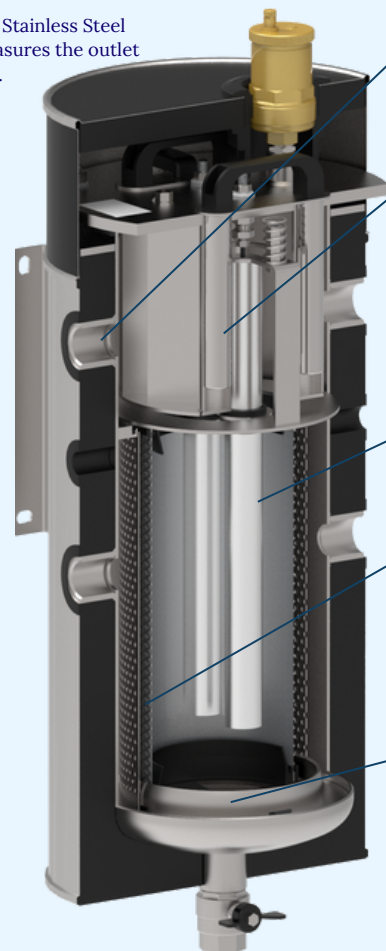

- 1 Inlet diverter:** Water entering the Protector is immediately directed towards the inner walls, accelerating the flow and creating a "vortex" that improves separation efficiency.
- 2 Neodymium Magnets:** These dry magnets are installed in front of the sacrificial anodes to protect them from ferrous particles, the neodymium magnets (total length 600mm) are coated in stainless steel to increase their durability and to make maintenance easier. In fact, they do not require manual cleaning because, once extracted from the filter thanks to the handle located on the lid, the dirt precipitates into the filtering element.
- 3 Sacrificial Anodes:** Magnesium Anodes that provide Cathodic protection and lower the fluids conductivity. The anodes also scavenge oxygen and regulate the pH.
- 4 Interchangeable filter elements / bags:** Stainless steel filters comes as standard at 40-micron nominal (55 absolute). S.S filter screens can be replaced with bag filters down to 1 µm. This guarantees a supremely clean circulation water that provides optimal values for the plant and its components.
- 5 Large collection area:** The base design ensures circulation is retained for longer periods, lengthening the time before a manual clean of the filter.

DIMENSIONS

PROTECTOR MINI & WALL BRACKET

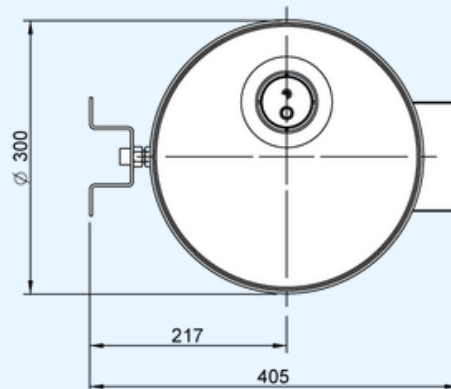
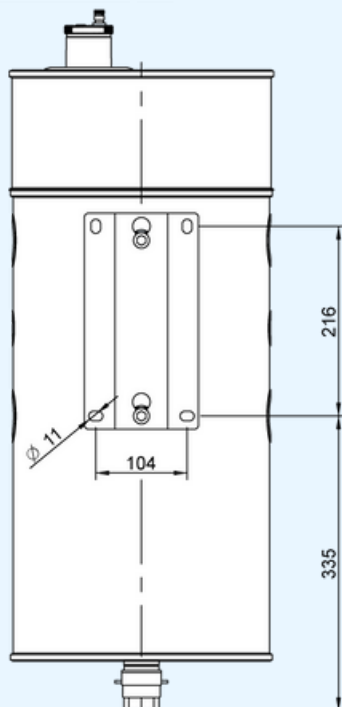
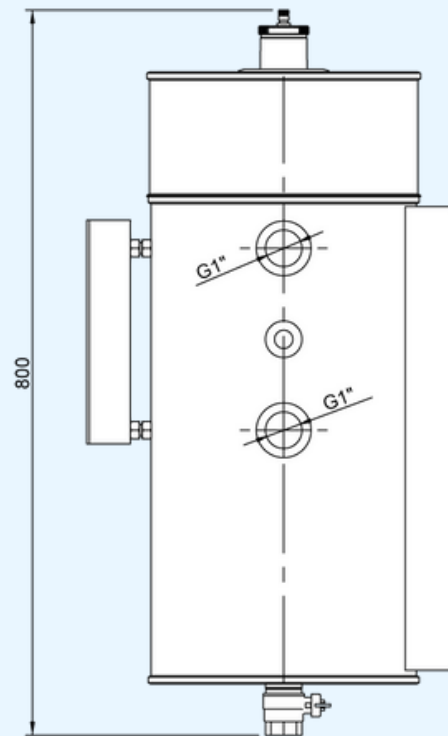
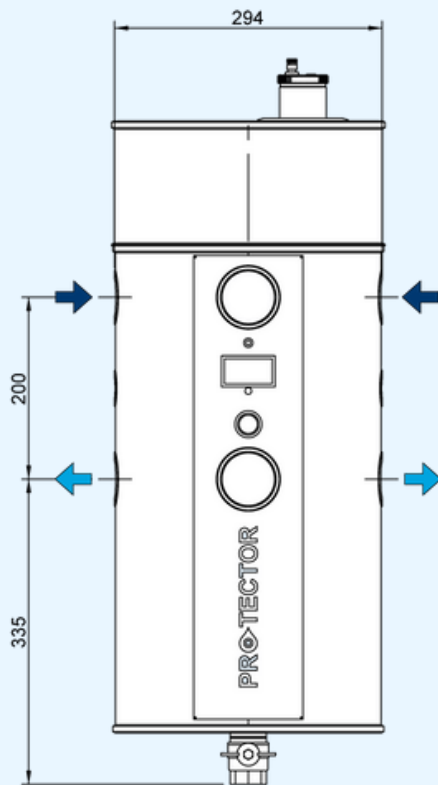

EMPTY WEIGHT: 33KG

FULL WEIGHT: 52KG

SHIPPING WEIGHT: 42KG

DIMENSIONS

PROTECTOR MINI & FLOOR MOUNT

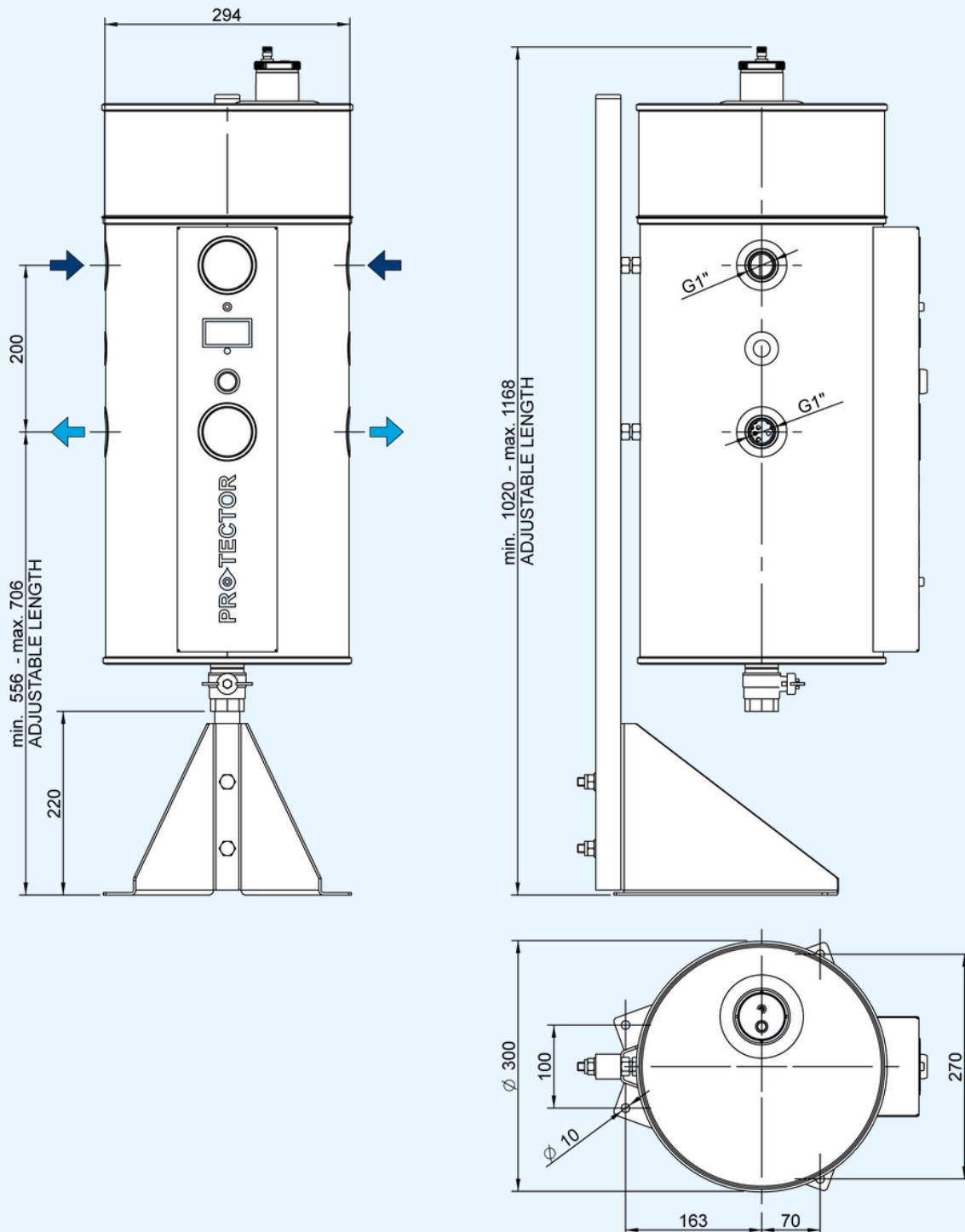

TECHNICAL DATA

TECHNICAL SPECIFICATIONS

Parameter	Value
System Volume	Max: 10m ³ - Heating 7m ³ - Cooling
Water Flow	10 l/min
Design Pressure (bar)	PN 10
Max. Temperature (°C)	95
Tank Volume	20L
Design code	PED 2014/68/EU
Connections	1" FBSP

*Flow rate referred to clean water at 110µm filtration degree.

MATERIALS

Component	Component Material
Filter Housing	Stainless Steel AISI 304
Filter Screen	Stainless Steel AISI 316L
Gaskets EPDM *	EPDM *
Insulation / cladding	Armaflex / Stainless Steel
Pressure Gauges	Stainless Steel AISI 304
Anodes	Magnesium
Magnets	Neodymium
Surface Finishing	Shot Peening and Passivation

*Certified for the following European Drinking Water regulations: UBA, DVGW standard W-270, WRAS and ACS.

HEAD LOSS

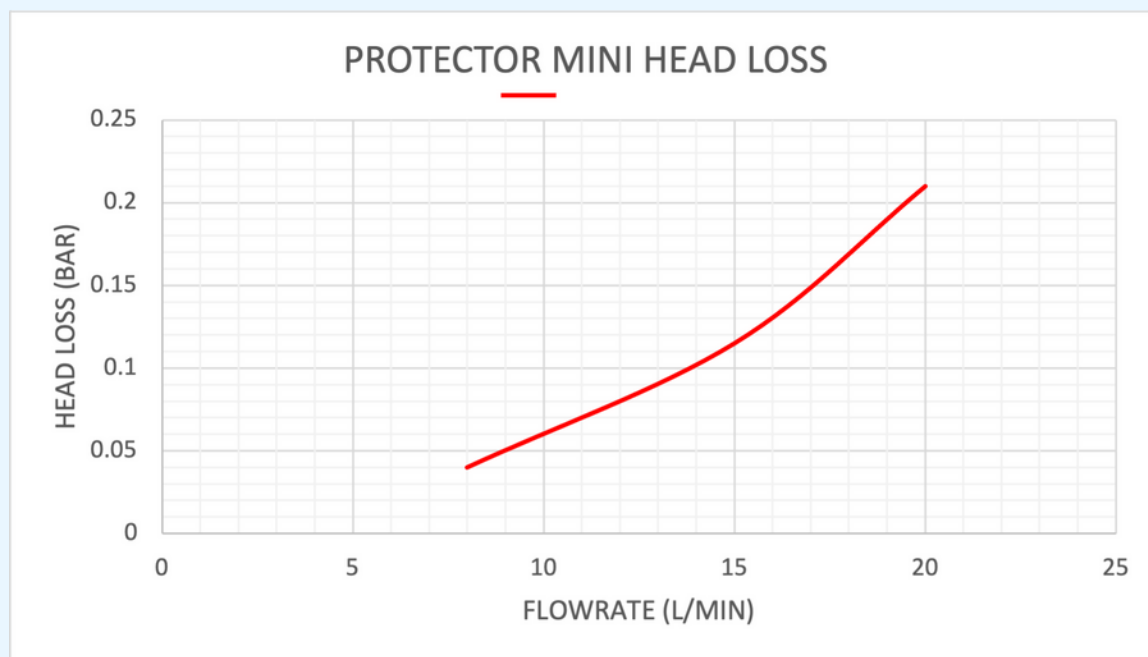

Head loss is calculated with 110µm stainless steel filter and clean water.

Note: Talk to us for higher pressure or temperature projects.

Environmental Culture Change

be a part of it

clean | protect | prevent



LETTER OF COMPLIANCE

IWTM is the Marine Division Partner of Elysator and have developed models specifically suited to the higher demands of the Marine industry operating at higher pressures and higher temperatures.

The marine products are provided worldwide on the World's largest cruise ships working with the leading operators in this sector. Having secured DNV approval in 2003, IWTM are still the only chemical free water treatment manufacturer to have this certification and approvals:

With over 30 years of experience in this technology IWTM has developed the Protector range of products. The Protector range is now available to Elysator UK's land-based customers.

SUTTON BUSINESS CENTRE
RESTMOR WAY
WALLINGTON SM6 7AH

WWW.ELYSATOR.CO.UK
T: +44 208 255 2903
E: INFO@ELYSATORUK.COM