

ELYSATOR ^E
engineering water

IWTM

PROTECTOR MASTER

2022



WWW.ELYSATOR.CO.UK

T: +44 208 255 2903

E: INFO@ELYSATORUK.COM

TABLE OF CONTENTS

03 PROTECTOR MASTER DESCRIPTION

04 PROTECTOR MASTER FUNCTIONS

05 FILTERING ELEMENTS

06 DETAILED INTERNAL AND EXTERNAL
VIEW

07 DIMENSIONS

08 TECHNICAL DATA

09 MULTI-UNITS



PROTECTOR MASTER DESCRIPTION

ALL-IN-ONE FILTRATION AND WATER TREATMENT UNIT.

WHAT IS IT?

The Protector Master is a product from our Marine partner IWTM.

Protector Master is a unique side stream filtration device that engineers the system water to a non-corrosive state. It provides corrosion protection in both new and existing heating and cooling systems, by removing sludge, particles, oxygen and other corrosive products. Therefore the system is maintained in the best possible way, by constantly filtering and engineering the water using electrochemistry and anode technology. The result is that its cleaning and engineering the water at the same time.

Each filter contains neodymium magnets to retain ferrous particles, magnesium anodes to consume oxygen and increase the pH value, and a stainless steel filter element (55µm) to filtrate the water and remove any suspended solids.

Protector Master is completely insulated and cladded to prevent heat loss and condensation.

In closed systems, typical installation will be in side stream, but it can also be installed in the main flow in a modular arrangement for larger systems. This provides a method of easy installation, operation and maintenance.

HOW DOES IT WORK?

The water enters from the inlet connection, then passes around and down past magnets and anodes. During this process, oxygen will be consumed by dissolving the anodes, and excess air will rise up and out of the vent valve. The water will now flow through the filter element/ filter bag so that particles will physically be stopped by either of the filters. The result will be clear water with controlled alkaline pH, without oxygen or particles and sludge.

MAINTENANCE

When the progressive build-up of suspended solids retained by the stainless-steel screen causes an excessive increase of pressure differential between the inlet and outlet connections, the screen must be cleaned. To perform the cleaning operations, there are two options either a normal backflush of the filter, or by complete removal and washing of the filter. The filter can be used to remove chemicals and inhibitors but works well with organic glycol.

PROTECTOR MASTER FUNCTIONS

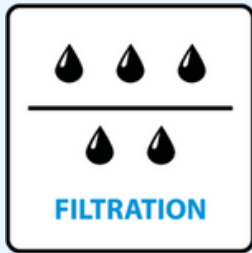

PARTICLE
FILTRATION



MAGNETIC
PROTECTION



REDUCES
DISSOLVED OXYGEN



CORROSION
PREVENTION

Prevents Corrosion

Protector's water treatment features prevent corrosion in the system. This is achieved thanks to magnesium anodes that lower oxygen, regulate pH and reduce electrical conductivity.

All In One

Protector is an "all in one solution". It combines several different technologies in one single extremely functional and reliable device.

Traps Ferrous Particles

Protector is equipped with Neodymium Magnets that trap ferrous particles, drastically increasing the time before manual intervention is needed.

Removes Contamination

Protector cleans and restores recirculating systems by removing suspended particles.

+ PROVIDES	- REPLACES
Sludge and particle removal	Bag filters
Magnetite Removal	Magnet filters
pH adjustment	Chemicals
Oxygen consumption	Air separators
Cathodic / anodic water treatment	Dosing pots + automatic dosing systems

PROTECTOR MASTER FUNCTIONS

FILTERING ELEMENTS

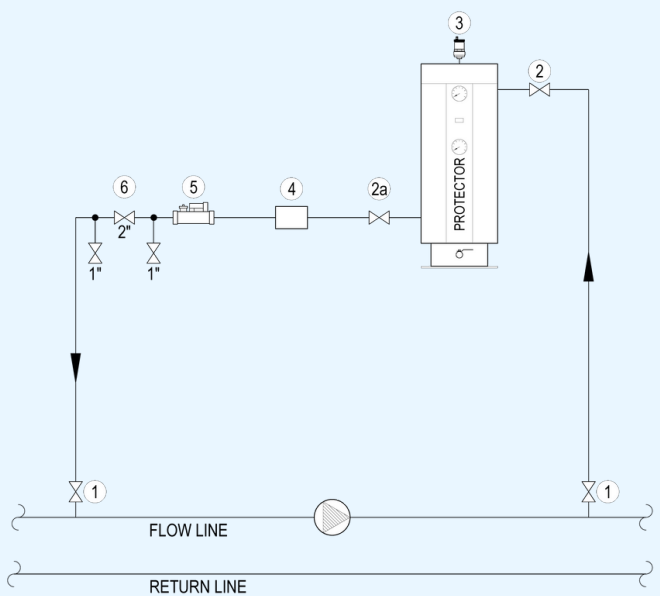

Protector Master keeps your system clean by adapting to your needs. Two different filtering elements, completely interchangeable, remove suspended particles from the recirculating system.

The use of different gauge filters by progressive stepped filtration helps to avoid filters blocking too early.

PARTICLE FILTRATION

Protector Master comes as standard with a robust stainless steel filter which is 40 micron nominal (55 absolute) . Stainless steel AISI 316, 55µm filter.

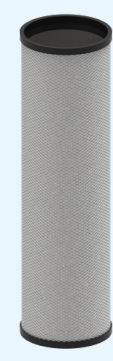

2-Layer S.S Filter

The filter has a large surface which gives a long operating time before cleaning and thus less flushing and refilling.

DETAILED EXTERNAL & INTERNAL VIEW



- 1 Vent pipe + automatic vent valve:** An automatic vent valve is installed at the top of the vent pipe.
- 2 Top insulation cap:** Easily removed when the Protector unit needs maintenance.
- 3 Inlet Pressure Gauge:** Stainless Steel pressure gauge that measures the inlet pressure. Scale 0-10 bar.
- 4 Vessel insulation and cladding:** External cladding in stainless steel and internal Armaflex insulation against cold/hot to prevent condensation.
- 5 Amp meter:** this indicator device measures the intensity of the current produced by the anode relative to the cathode, which is directly related to the corrosiveness of the system water.
- 6 Amp meter button:** tests operation of the swing meter.
- 7 Outlet Pressure Gauge:** Stainless Steel pressure gauge that measures the outlet pressure. Scale 0-10 bar.

8 Drain: The filter is emptied with a manual valve installed on the drain pipe. Can be easily connected to any existing drain manifold / pipe or automatic drain.

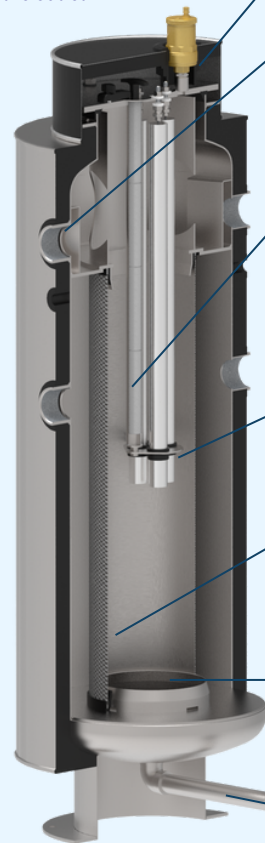

- 1 Vent valve + vent pipe (not shown):** An automatic vent valve is installed at the end of the vent pipe.
- 2 Inlet diverter:** Water entering the Protector is immediately directed towards the inner walls, accelerating the flow and creating a "vortex" that improves separation efficiency.
- 3 Neodymium Magnets:** These dry magnets are installed in front of the sacrificial anodes to protect them from ferrous particles, the neodymium magnets (total length 600mm) are coated in stainless steel to increase their durability and to make maintenance easier. In fact, they do not require manual cleaning because, once extracted from the filter thanks to the handle located on the lid, the dirt precipitates into the filtering element.
- 4 Sacrificial Anodes:** Magnesium Anodes that provide Cathodic protection and lower the fluids conductivity. The anodes also scavenge oxygen and regulate the pH.
- 5 Interchangeable filter elements / bags:** Stainless steel filters comes as standard at 40 micron nominal (55 absolute). S.S filter screens can be replaced with bag filters down to 1 µm. This guarantees a supremely clean circulation water that provides optimal values for the plant and its components.
- 6 Large collection area:** The base design ensures circulation is retained for longer periods, lengthening the time before a manual clean of the filter.
- 7 Drain:** The filter is emptied with a manual valve installed on the drain pipe. Can be easily connected to any existing drain manifold / pipe.

DIMENSIONS

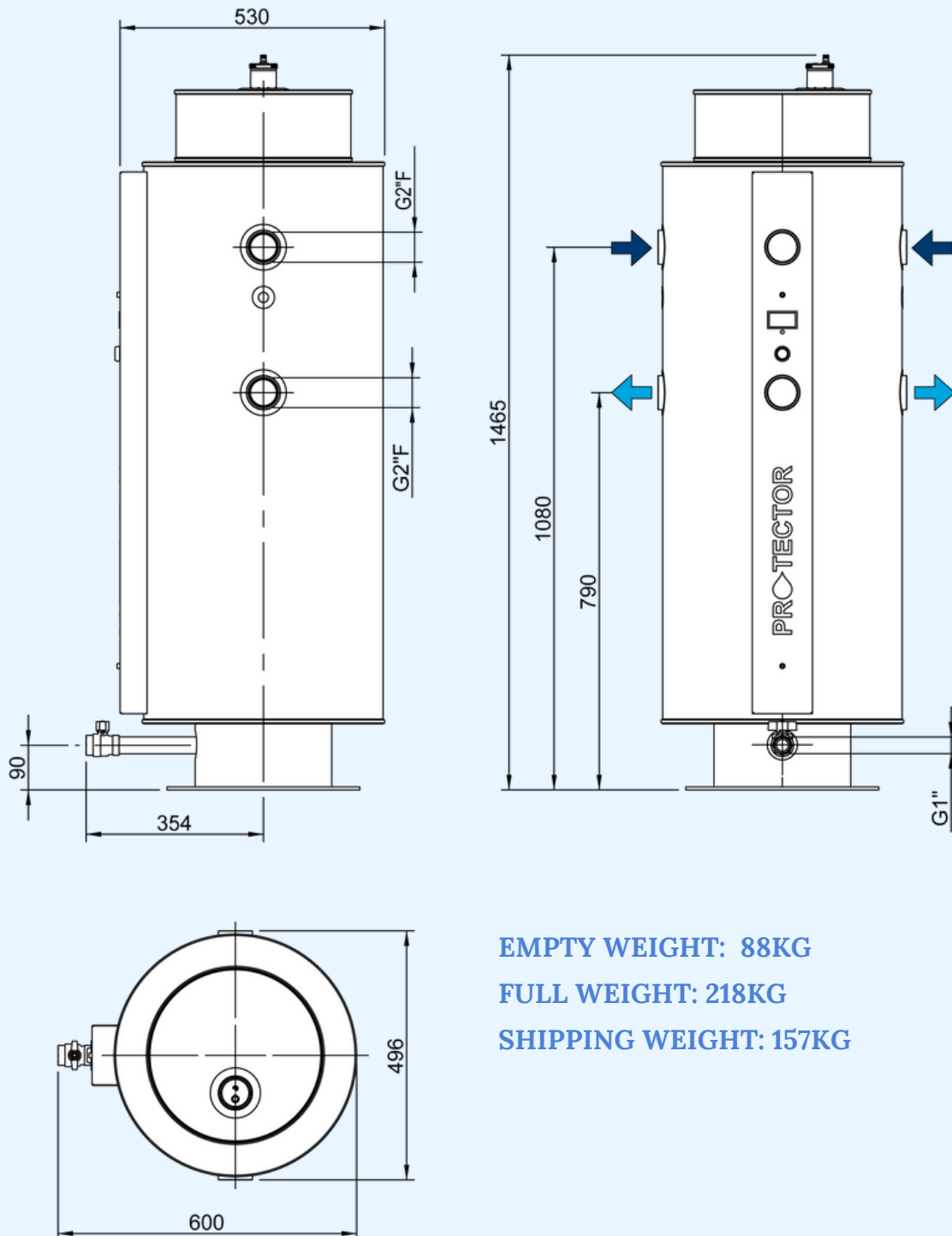

EMPTY WEIGHT: 88KG
FULL WEIGHT: 218KG
SHIPPING WEIGHT: 157KG

TECHNICAL DATA

TECHNICAL SPECIFICATIONS

Parameter	Value
System Volume	Max 70m ³
Water Flow	70 l/min
Design Pressure (bar)	PN 10
Max. Temperature (°C)	95°C
Tank Volume	120L
Design code	PED 2014/68/EU
Connections	2" Female BSPP

*Flow rate referred to clean water at 110µm filtration degree.

HEAD LOSS

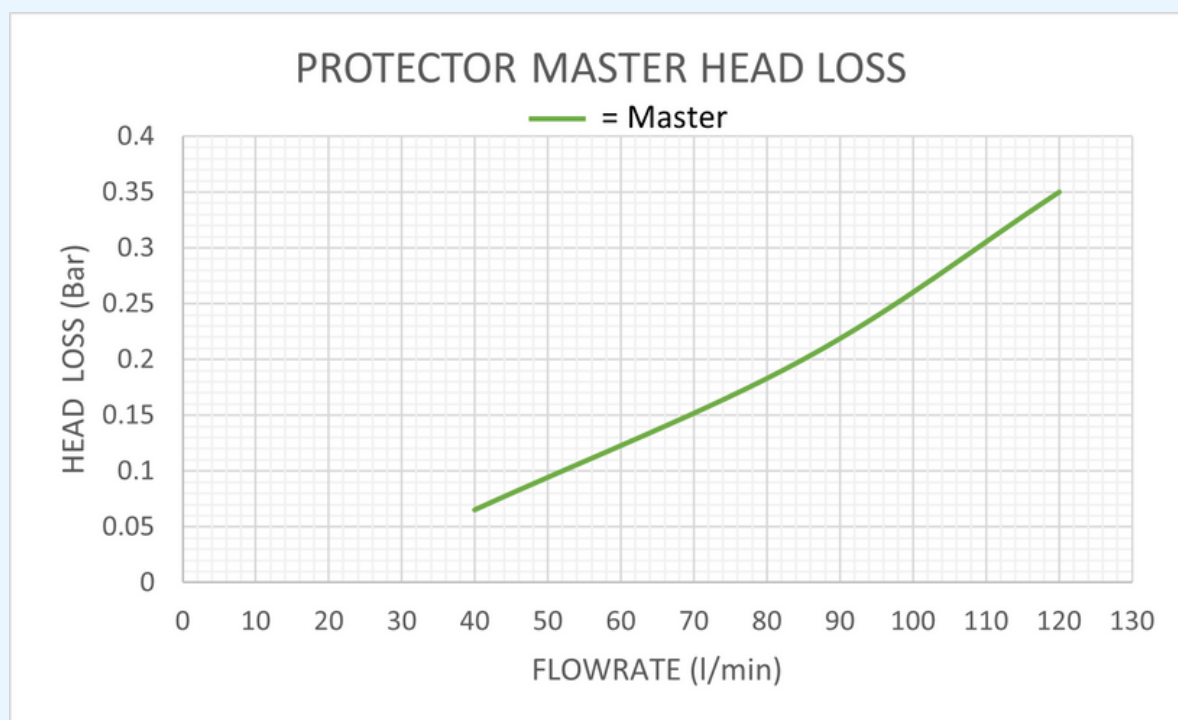

Head loss is calculated with 110µm stainless steel filter and clean water.

Note: Talk to us for systems that operate at higher pressures or higher temperatures.

MATERIALS

Component	Component Material
Filter Housing	Stainless Steel AISI 304
Filter Screen	Stainless Steel AISI 316L
Gaskets EPDM *	EPDM *
Insulation / cladding	Armaflex / Stainless Steel
Pressure Gauges	Stainless Steel AISI 304
Anodes	Magnesium
Magnets	Neodymium
Surface Finishing	Shot Peening and Passivation

*Certified for the following European Drinking Water regulations: UBA, DVGW standard W-270, WRAS and ACS.

MULTI-UNITS



COMPACT MULTI-UNIT SOLUTION FOR HIGHER VOLUMES

For systems with higher volumes, Protector Master can be supplied in multi-units with manifolds ready to be assembled and installed, designed to be compact and space saving. The kit includes the Protector Master, manifolds, isolation valves and all accessories - it is modular and can be tailored to suit existing systems.

AN EFFICIENT ALTERNATIVE

Protector Master modules take up less space and make the installation and handling easier than one large unit, where access may be a problem.

During operation, the Protector multi-units work as a large all-in-one system, but when maintenance is needed, they are as easy and quick to clean as a single unit and do not require a complete emptying of the tank.

FILTERING AND CLEANING CONTINUE DURING MAINTENANCE

When the filtering element needs to be cleaned, and maintenance is necessary, there is no need to stop the entire system.

Each Protector unit can be isolated, cleaned and re-started while the others keep working. This ensures that regular maintenance operations do not affect the quality of the protection and prevention offered by Protector Master.

READY TO GO

The systems are supplied with pre-assembled components ready for final assembly on site for ease of installation. As soon as they are installed in the circuit, they start protecting the plant.

MODULAR SYSTEM + DIFFERENT LAYOUT OPTIONS

The systems are modular and can be manufactured depending on the number of units required (2, 4, 6, 12, etc.) to match the required flow rate. In addition to the number of desired units, they can be designed to work in parallel or in series.



MULTI-UNITS

2 + FILTRATION DEGREES (IN SERIES)

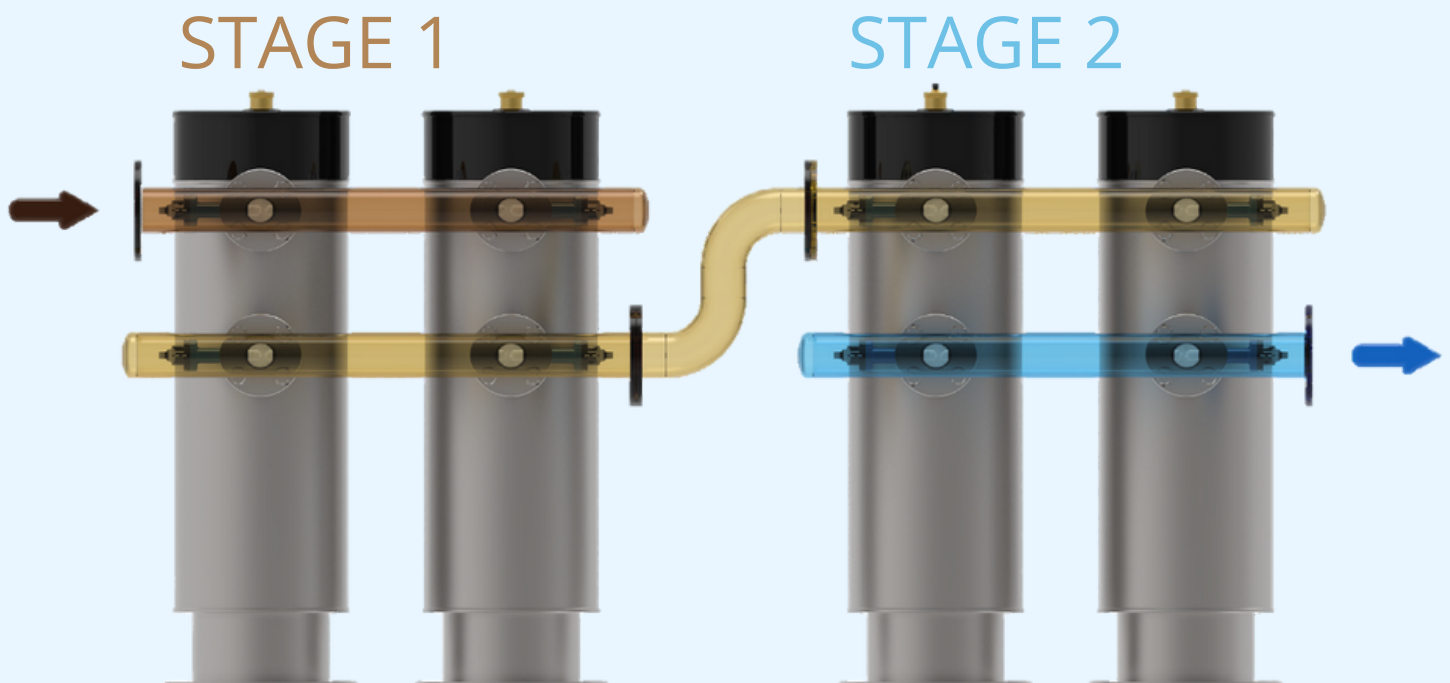

The unit's installed in series, with a connection pipe between each module's in/out manifolds, allow the customer to have two or more (depending on the number of modules) filtration levels in the same system. For example, the customer can start with the standard 55µm (with the stainless-steel mesh) and finish with a 1µm bag filter.

MULTI-UNITS





LETTER OF COMPLIANCE

IWTM is the Marine Division Partner of Elysator and has developed models specifically suited to the higher demands of the marine industry operating at higher pressures and higher temperatures.

The marine products are provided worldwide on the world's largest cruise ships working with the leading operators in this sector. Having secured DNV approval in 2003, IWTM are still the only chemical free water treatment manufacturer to have this certification and approval.

With over 30 years of experience in this technology IWTM has developed the Protector range of products. The Protector range is now available to Elysator UK's land-based customers.

SUTTON BUSINESS CENTRE
RESTMOR WAY
WALLINGTON SM6 7AH

WWW.ELYSATOR.CO.UK
T: +44 208 255 2903
E: INFO@ELYSATORUK.COM