

beingTM

Design solutions with
every body in mind

orangebox

being^{me}_™

can be precisely tailored to help meet the needs of anyone with specific seating requirements or for those people who spend more of their time at a dedicated workstation.

P 03–06

being^{us}_™

shares the same visual design but is more of a general use task chair with solid ergonomic features to suit most people and help them to stay healthy and productive within more agile working environments.

P 07–09

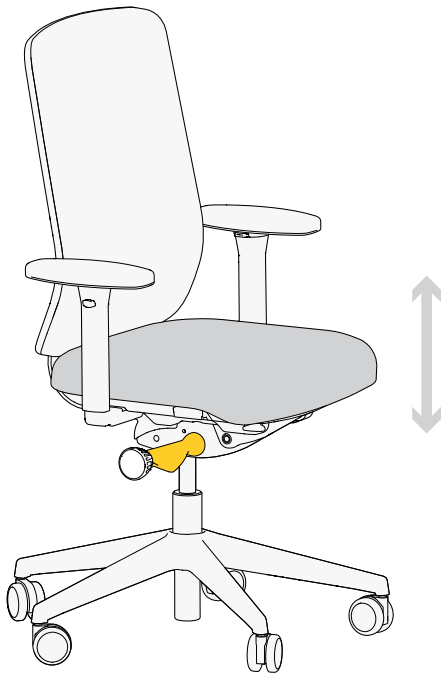

Seat height

When sat in the chair, pull the right hand control paddle up and either press your weight down or slightly lift up from the seat to adjust the height. Release the control to lock the seat at the desired height.

To help keep your pelvis upright and your spine aligned in a natural 'S' shape, thigh to torso angle should be 90° or slightly more.

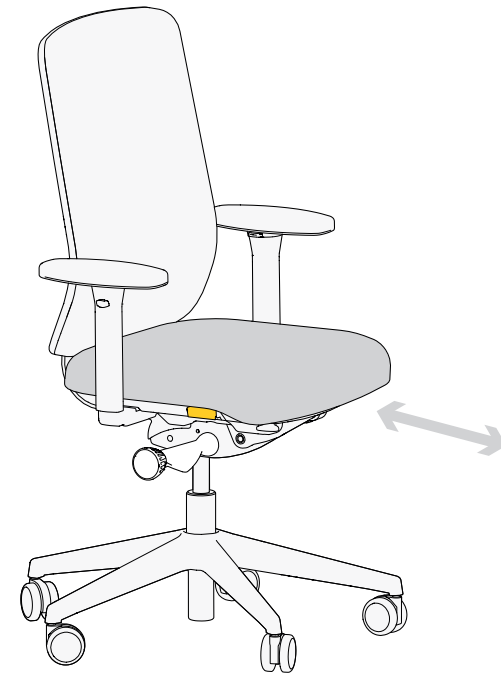

Seat depth

When sat in the chair, pull the right hand control lever out (positioned at the front of the seat) and slide the seat forwards or backwards into the desired position. Release the control to lock the seat at the required depth.

To ensure adequate thigh support without obstructing leg movement, up to three fingers gap should be left between the front of the seat and the back of your knees.

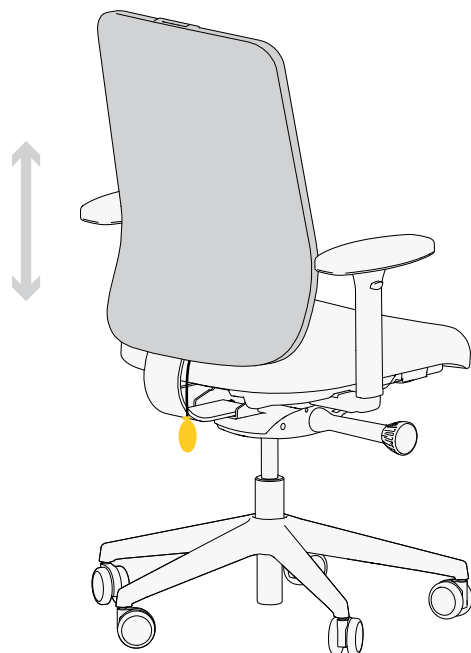

Back height & Inflatable lumbar-cell

To adjust the back height, grip the back and lift up. Make sure the height is set to ensure the pronounced curvature of the backrest sits in the small of the back. Pull the backrest to the top and it will return to the lower point.

The lumbar area of the backrest can be inflated to the desired shape by squeezing the bulb repeatedly. To reduce the size, press the button just above the bulb. The support should fill the area around the belt line without any gaps but not over inflated to feel too hard.

The backrest should support the natural 'S' shape of the spine.



Headrest adjustment optional

To adjust the head rest grip it underneath and pull up or push down to achieve the correct height. The headrest can be adjusted in depth by rotating the padded area to suit. There is also a thumb screw to loosen off the articulated arm section if you need more or less reach. Once in position, tighten up the thumb screw.

Ensure it's positioned to support the nape of your neck when you are sat in the upright working position.

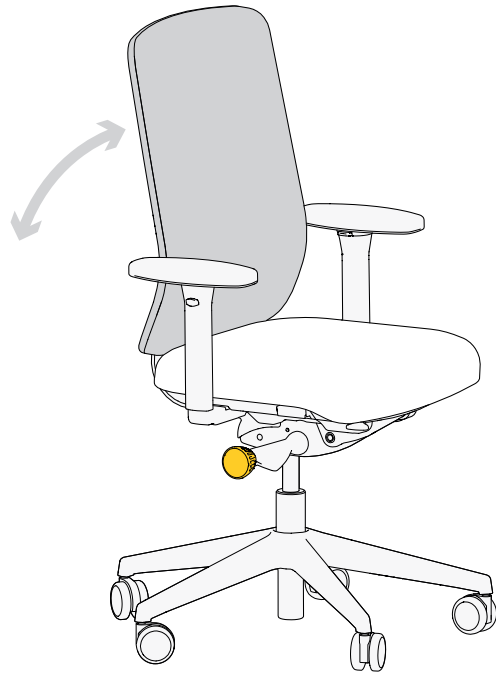

Back recline tension

To balance the chair to suit your body weight, turn the body weight control - clockwise to increase and anti-clockwise to decrease the resistance. Make sure when the chair is unlocked that it's not too hard to recline, or too weak that you don't feel supported.

You can lock the back into position by pulling up the back lock paddle.



Back lock

When sat in the chair, pull the paddle up on the left hand side to lock the chair in one of 4 positions from upright to fully reclined.

Keeping the chair unlocked most of the time will allow you to make full use of the chairs movement, improving blood circulation.

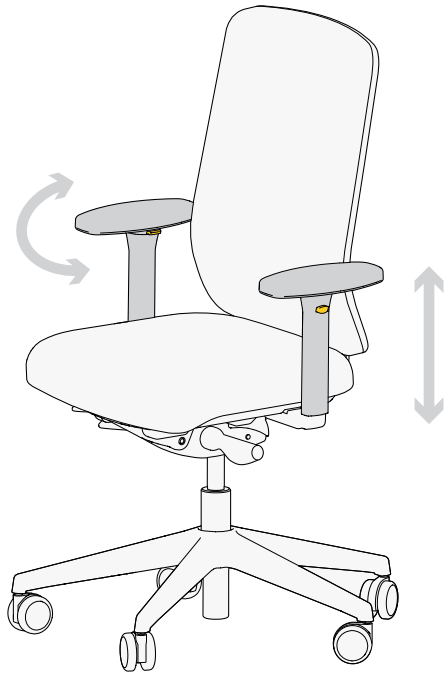

Arm adjustment

Press in the button on the outside of the arm and move the arm up or down into the desired position. Release the button to lock in position. The arm pad can be rotated 180° by pressing the button close to the pad on the inside of the arm to increase or decrease arm pad width.

Make sure your shoulders and upper arms are relaxed by your side, and the forearms are at right angles when the arm pads are just touching your forearms.

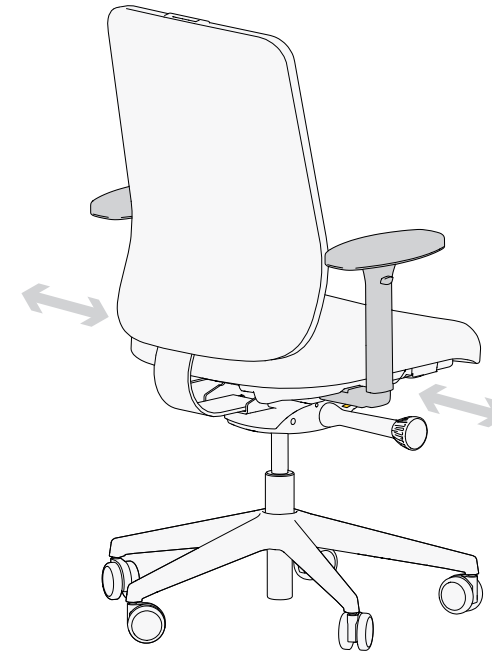

Arm width

Pull down the lever on the underside of the arm bar and slide the arm outwards. Lock the arm width into position by pulling the lever upwards.

You can adjust the angle of the arm pad by pressing the button on the inside of the arm and twisting the pad into position. The arm pads can also be pushed backwards.

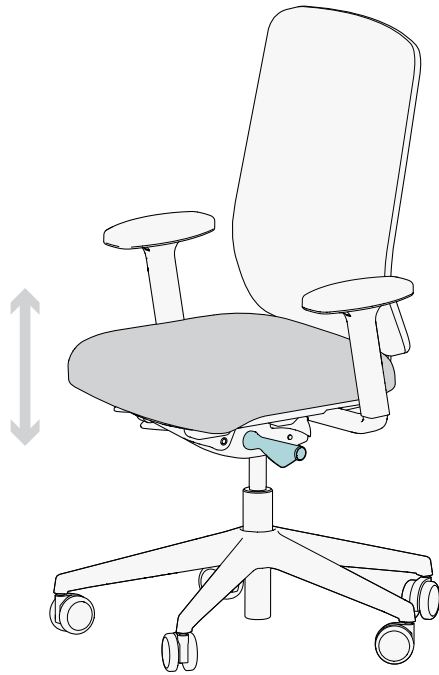

Seat height

When sat in the chair, pull the left hand control paddle up and either press your weight down or slightly lift up from the seat to adjust the height. Release the control to lock the seat at the desired height.

To help keep your pelvis upright and your spine aligned in a natural 'S' shape, thigh to torso angle should be 90° or slightly more.

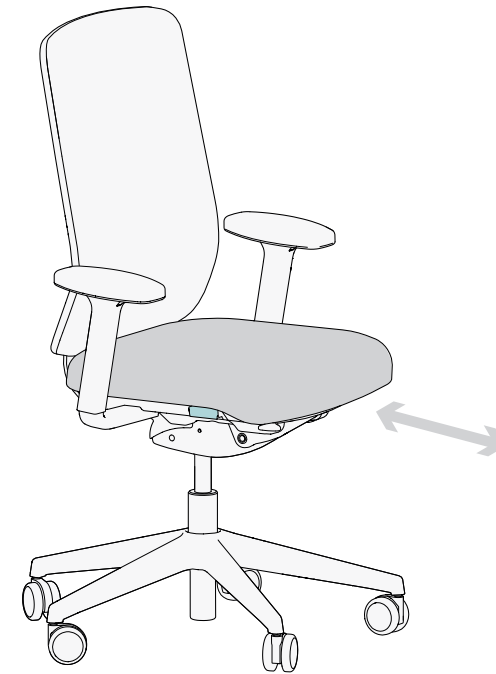

Seat depth

When sat in the chair, pull the right hand control lever out and slide the seat forwards or backwards into the desired position. Release the control to lock the seat at the required depth.

To ensure adequate thigh support without obstructing leg movement, up to three fingers gap should be left between the front of the seat and the back of your knees.

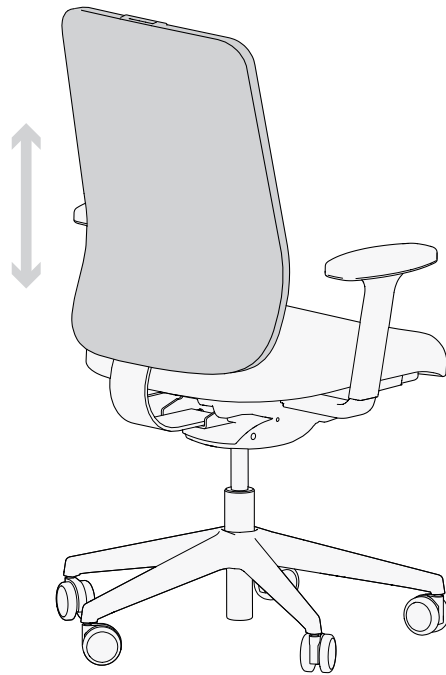

Back height

To adjust the back height, grip the back and lift up. Make sure the height is set to ensure the pronounced curvature of the backrest sits in the small of the back. Pull the backrest to the top and it will return to the lower point.

You can use the inflatable lumbar pumps to fine tune the amount of additional lumbar padding you may need.



Back recline tension & limiter

To balance the chair to suit your body weight, turn the body weight control (which is situated under the front of the chair) clockwise to increase and anti-clockwise to decrease the resistance. Make sure the chair is not too hard to recline, or too weak that you don't feel supported.

You can limit the recline by pulling up the back lock paddle.

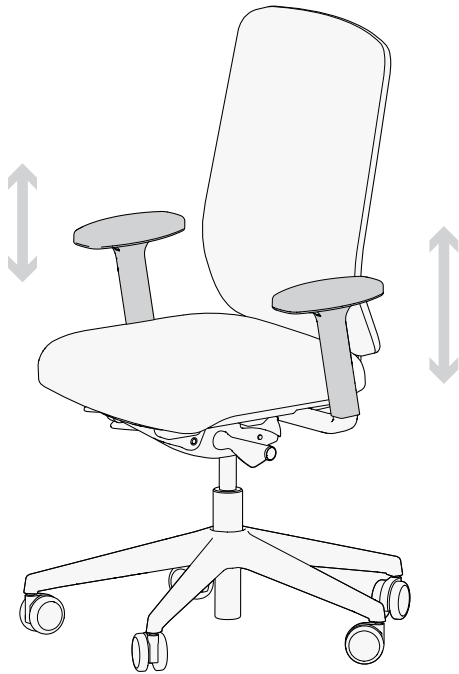

Arm height

Press the button in on the underside of the front of the arm and move the arm up or down into the desired position. Release the button to lock in position.

Make sure your shoulders and upper arms are relaxed by your side, and the forearms are at right angles when the arm pads are just touching your forearms.

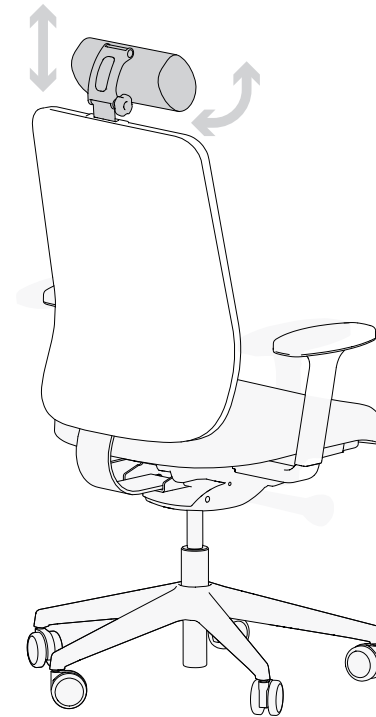

Headrest adjustment optional

To adjust the head rest grip it underneath and pull up or push down to achieve the correct height. Ensure it's positioned to support the nape of your neck when you are sat in the upright working position.

The headrest can be adjusted in depth by rotating the padded area to suit. There is also a thumb screw to loosen off the articulated arm section if you need more or less reach. Once in position, tighten up the thumb screw.

Smartworking® London

38 Northampton Road,
London EC1R 0HU, United Kingdom.
T. +44 (0)20 7837 9922
email. showroom@orangebox.com

Head Office & Manufacturing

Orangebox Limited, Parc Nantgarw,
Cardiff CF15 7QU, United Kingdom.
T. +44 (0) 1443 816 604
email. sales@orangebox.com

Smartworking® Huddersfield

Bates Mill, Colne Road,
Huddersfield HD1 3AG, United Kingdom.
T. +44 (0)1484 536 400
email. smartworkinghuddersfield@orangebox.com

Smartworking® Dubai

Dubai Design District, Building 3 Office 504,
PO Box 333016, Dubai, UAE.
T: +971 (0)4770 7900
email. smartworkingdubai@orangebox.com

Smartworking® New York

320 5th Avenue, Suite 600,
New York, NY 10001
email. nyc@orangebox.com

orangebox