

KLINGER

EDUCATIONAL PRODUCTS

Inspiring Educators Since 1975

KM1500 BlackBoard Mechanics™

Instruction Sheet

06/15 ALF

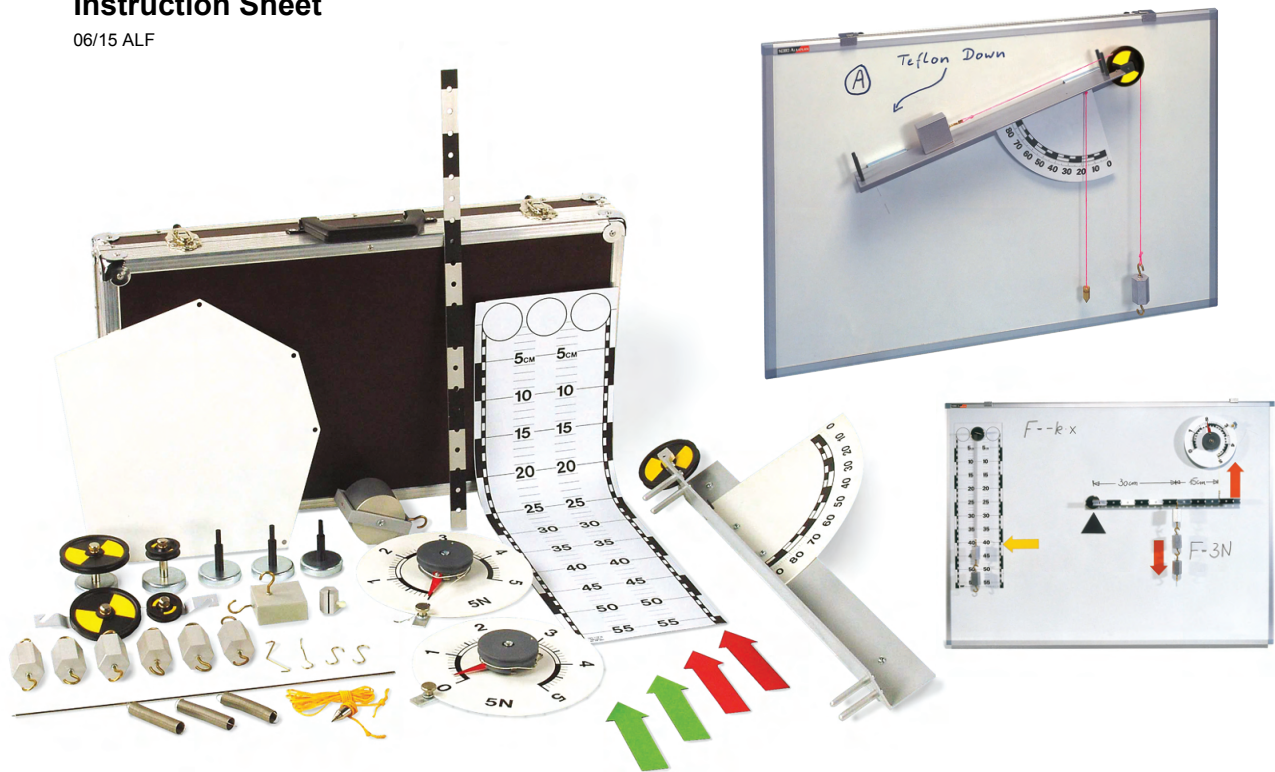

1. Description

The Mechanics Kit – Statics allows performing of all basic experiments on statics. As a special feature all elements are equipped with strong magnetic holders, so that the experimental set-ups can be done securely on a vertical magnetic board. In this way there is no need for any base material and all elements can easily be shifted on the board for quick arrangement of new experiments. The vertical set-up and the large components ensure good visibility from a distance. As there is no base material, its disturbing influence ceases to exist. Furthermore it is possible to write notes directly on the board next to the experiment. If needed the components can be named and physical values, that are

measured and changed, can be charted, e.g. lengths and forces in their actual position. Finally a sketch can be drawn next to the experiment, which shows the basic configuration of that experiment. This sketch can be drawn before setting up the experiment, so that the set-up is done according to the drawing. If the sketch is drawn after the experiment, it is possible to highlight the fundamental principals of the experiment. In this way forces and parallelograms of forces can be depicted for example.

A magnetic board with dimensions of at least 100x100 cm is required for realizing the experiments.

2. Scope of delivery

No.	Component	Quantity
1.	Dynamometers 5 N	2
2.	Inclined plane with fixed pulley and protractor	1
3.	Hooked roller 5 N	1
4.	Aluminium friction block with 2 hooks 2 N	1
5.	Hooked weights 1 N	6
6.	Small pulley	1
7.	Large pulley	1
8.	Double pulley block	1
9.	Lever	1
10.	Steel rod, threaded	1
11.	Counter weight with knurled screw	1
12.	Coil springs	3
13.	Centre of gravity plate	1
14.	Plumb	1
15.	Anchor post	3
16.	Rubber grommets	3
17.	Brass hook	3
18.	Brass clip	1
19.	Magnetic scale	1
20.	Magnetic arrows	4
21.	Magnetic triangle	1
22.	Strings with nooses	4

3. Experiments with the kit

The character of force, combination and resolution of forces

1. Measurement of a force with a dynamometer – force as a vectorial value
2. Shifting of a force along the line of action
3. Hooke's law
4. Combination of forces with common line of action
5. Action equals reaction
6. Combination of forces of different line of actions – using dynamometer
7. Combination of forces of different line of actions – using hooked weights
8. Resolution of a force into two components, perpendicular to each other
9. Resolution of a force into two parallel components

Centre of gravity and states of equilibrium

10. Gravity lines and centre of gravity of a plastic plate
11. States of equilibrium of a hanging body
12. States of equilibrium – centre of gravity outside the lever

Devices to transform forces

13. Equilibrium of forces at the two-sided lever
14. Equilibrium of forces at the one-sided lever
15. Torque
16. Forces at the fixed pulley
17. Forces at the movable pulley
18. Forces at the block and tackle
19. Forces at the inclined plane – using a dynamometer
20. Forces at the inclined plane – using hooked weights
21. Dynamic friction – using a dynamometer
22. Dynamic friction – using weights
23. Static friction
24. Roll friction

Oscillations

25. Period length of a string pendulum
26. Period length of a vertical spring oscillator
27. Resonance of two spring oscillators

4. Notes on some components

1. Dynamometer

The dynamometer can be used in any position. If needed the weight of the strings, hooks etc. have to be taken into account. Its influence is small however when using great forces. The zero position of the pointer can be reached by turning the scale disc. The string has to be wound clockwise onto the scale disc.

2. Inclined plane

The inclined plane can be easily mounted in different angles. The hanging plumb line shows the actual angle.

3. Double pulley block

The Double pulley block can also be used as a movable pulley, just unscrew one pulley. Then the experimental set-up is clearer and the weight of the pulley lower.

4. Magnetic arrows and triangle

The directions of forces or movements in the experiments can be marked with the magnetic arrows. Because of the same lengths of the arrows it should be noted that for forces of different amounts the arrows do not reflect the amount of the forces correctly.

With the magnetic triangle the centre of gravity can be clearly marked.

5. Performing the experiments

1. Measurement of a force with a dynamometer – force as a vectorial value

Equipment

1. Dynamometer
2. Hooked roller
3. Aluminium friction block with two hooks
4. Hooked weight
5. Brass hook
6. 3 strings with nooses, different lengths

Experimental set-up

- Position the dynamometer on the upper part of the magnetic board.
- Attach a string to it and the brass hook to the string.

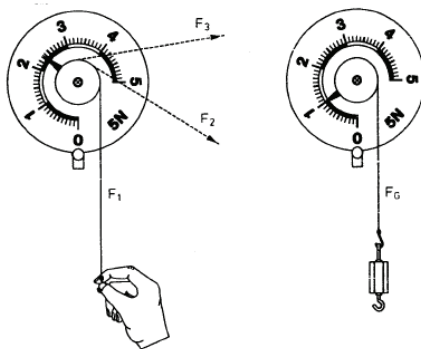

Fig. 1

Experiment procedure

- Perform by hand a gradually stronger force on the dynamometer.
- Let the force act in different directions.
- Finally hang the hooked weight, the friction block and the roller onto the dynamometer.

Result

Forces have different amounts and they can act in different directions. The weight is directed

vertical to the ground. To describe a force the amount and the direction are needed.

2. Shifting of a force along the line of action

Equipment

1. Dynamometer
2. 3 hooked weights
3. Brass hook
4. 3 strings with nooses

Experimental set-up

- Position the dynamometer on the upper part of the magnetic board.
- Attach the three strings to the measuring point.

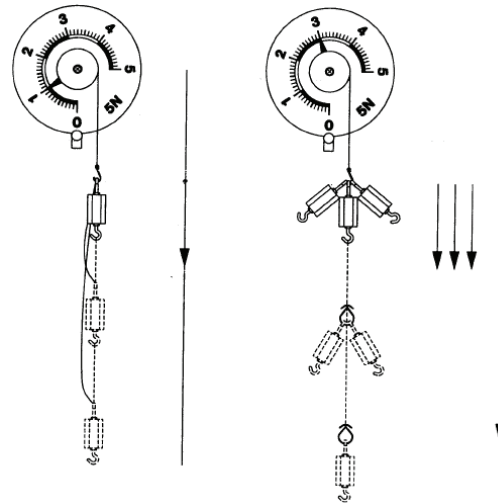

Fig. 2

Experiment procedure

- First attach one weight to the hook of the dynamometer and determine the force.
- Then hang this hooked weight to the lower from noose to noose.
- Next 3 hooked weights are attached to the dynamometer.
- Finally hang one and then the other two hooked weights to the lower nooses.
- Always determine the force.

Result

It is possible to shift a force along its line of action.

3. Hooke's law

Equipment

1. 3 hooked weights
2. 2 coil springs
3. Anchor post
4. Rubber grommet
5. Magnetic scale

Experimental set-up

- Position the magnetic scale vertically on the board.
- Put the anchor post on the upper end.
- Attach the spring to the anchor post and secure it with the rubber grommet.

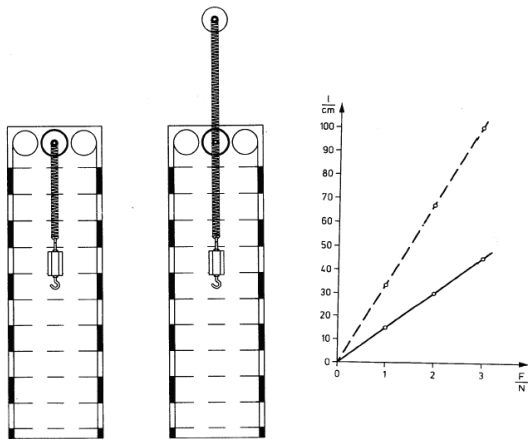

Fig. 3

Experiment procedure

- Mark the position of the lower end of the spring.
- Attach one hooked weight to the spring, measure the extension and enter it into the table.
- Next suspend two and three hooked weights from the spring and determine the respective change of length.
- Repeat the experiment with two springs hanging beneath each other. It is advisable to position the anchor post for the spring above the scale.
- Again the respective change of length and the weights should be entered into the table.
- Plot the change of length as a function of the force.

Table

Weight of the hooked weight F_G in N	Change of length of one spring Δl in cm	Change of length of two springs Δl in cm
0		
1		
2		
3		

Result

The greater the force the longer is the extension. Hooke's law applies: $\Delta l \sim F$. The extension at a certain force is dependent on the property of the spring.

4. Combination of forces with common line of action

Equipment

1. Dynamometer
2. 5 hooked weights
3. 2 strings with nooses

Experimental set-up

- Position the dynamometer on the upper part of the board.
- Attach both strings with nooses to it.

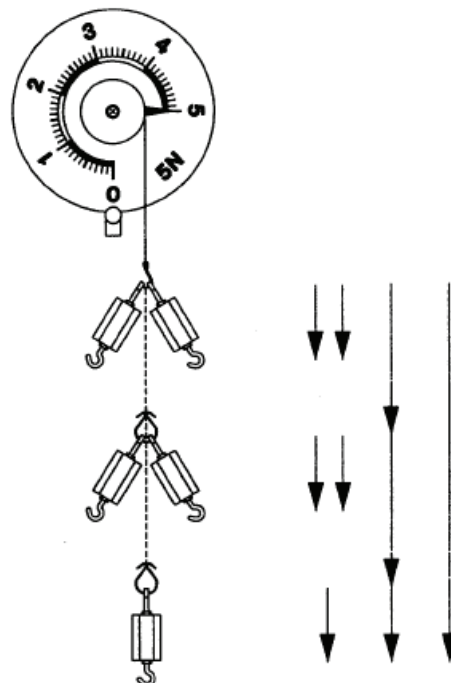

Fig. 4

Experiment procedure

- First attach one hooked weight to the dynamometer, then the others stepwise, alternatively to the dynamometer or to the strings.
- In all cases the forces shown have to be read.

Result

If all forces act in one line of action the total force equals the sum of the part forces. The direction of the total force is the same as that of the part forces.

5. Action equals reaction

Equipment

1. 2 dynamometers
2. String with nooses

Experimental set-up

- Position the two dynamometers next to each other on the magnetic board and attach the short string to the hooks. At first the string is not tightened.

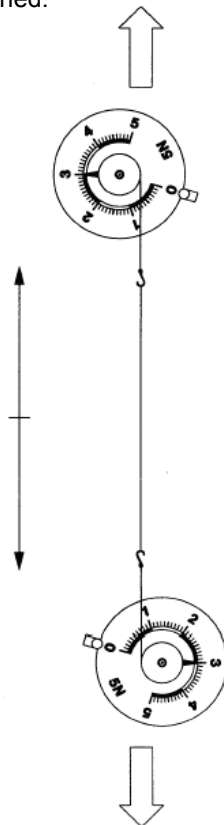

Fig. 5

Experiment procedure

- Shift the left dynamometer more and more to the left.

If the string is tight, each dynamometer shows a force. The forces increase with the movement of the dynamometer. They are equal in all cases.

- Return the left dynamometer to its starting point and gradually shift the right dynamometer outwards.

With the growing distance between the dynamometers always two equal forces arise.

Result

If a force acts on a body, the body reacts with a force of equal amount but opposite direction: action equals reaction.

6. Combination of forces of different line of actions – using dynamometer

Equipment

1. 2 Dynamometers
2. Coil spring
3. Centre of gravity plate
4. 3 anchor posts
5. 3 rubber grommets
6. Hook
7. String with nooses

Experimental set-up

- Position the two dynamometers on both sides of the upper half of the board and connect them with the string.
- Hang the hook with the coil spring on this string.
- Stretch the spring downwards and fix it in this position with the anchor post with rubber grommet.
- An additional anchor post has to be positioned at the place where the hook is.
- Mount the centre of gravity plate in front of the coil spring on the third anchor post so that the spring is hidden and only the hook with anchor post is visible.

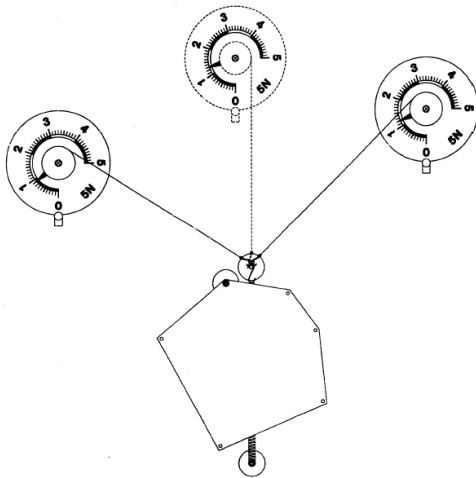

Fig. 6

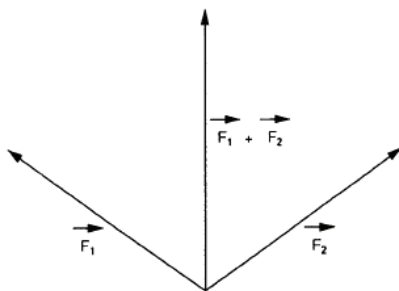

Fig. 6 a

Experiment procedure

- Shift both dynamometers so that the hook does not touch the anchor post any more.
- In this position two forces act on the hook, which are in equilibrium with the force of the spring.
- Draw both forces of the dynamometers in direction and amount on the board.
- Then remove one dynamometer from this set-up and attach the free noose to the measuring point of the remaining dynamometer.
- Shift this dynamometer so that the hook does not touch the anchor post any more.

In this case the force exerted by the dynamometer has the same effect as the two single forces before.

- Draw amount and direction of this force onto the board.

It is represented by the diagonal in the parallelogram of forces.

Result

If two forces act on a body in different directions they can be replaced by one single force. Amount and direction of this force can be determined from the diagonal of the parallelogram of forces.

7. Combination of forces of different line of actions – using hooked weights

Equipment

1. Dynamometer
2. Large pulley
3. Small pulley
4. 6 hooked weights
5. Coil spring
6. Centre of gravity plate
7. 3 anchor posts
8. 3 rubber grommets
9. Brass hook
10. String with nooses, long

Experimental set-up

- Position the two pulleys on both sides of the upper half of the board.
- Put the string over the pulleys and hang 2 hooked weights to it.
- Mount the spring in the lower part of the board on an anchor post with one grommet.
- Connect the other end of the spring with a hook to the string.
- Shift the anchor post downward until the wanted angle between the forces pointing diagonal upwards is reached.
- Next add an anchor post to the position of the hook. Take care that the hook does not touch the post.
- Mount the centre of gravity plate with an additional anchor post so that the spring is hidden and only the hook and the anchor post are visible.

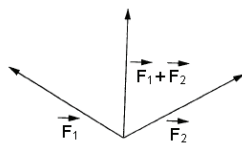
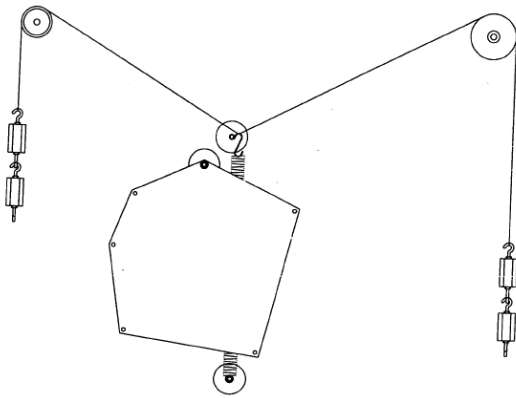

Fig. 7

Experiment procedure

Each of the hooked weights exerts a force on the hook so it remains in this position.

- Draw both forces on the board so that they represent the length and direction of the force vectors.

The objective is to replace these two forces by one force to reach the same effect.

- Replace the string and the hooked weights with a dynamometer and shift it upwards respectively sideways until the hook floats free again in the same position as before.

The dynamometer exerts the same force onto the hook as the hooked weights did before.

- Draw amount and direction of the dynamometer force onto the board.

After removing the dynamometer one can see that the resulting force is equal to the diagonals in the parallelogram of forces of the two single forces.

Result

If two forces act on a body in different directions they can be replaced by one single force. The diagonal in the parallelogram of forces starting from the point of application of the two forces is equal in the amount and direction to the sum of the two single forces.

8. Resolution of a force into two components, perpendicular to each other

Equipment

1. 2 dynamometers
2. 5 hooked weights
3. Pulley
4. Anchor post
5. Rubber grommet
6. Brass hook
7. 2 strings with nooses

Experimental set-up

- Position one dynamometer in the middle of the left part of the board and the other one in the middle of the upper part.
- Connect these with a short string with nooses.
- Hang the brass hook on this string and add another string to the hook.
- Hang the 5 hooked weights into the free noose and put the string over a pulley so that it pulls diagonal right downward.
- Change the position of the upper dynamometer so that the two forces originating from the dynamometers are at a right angle.
- Add the anchor post to the position of the brass hook. Take care that the hook does not touch the post.

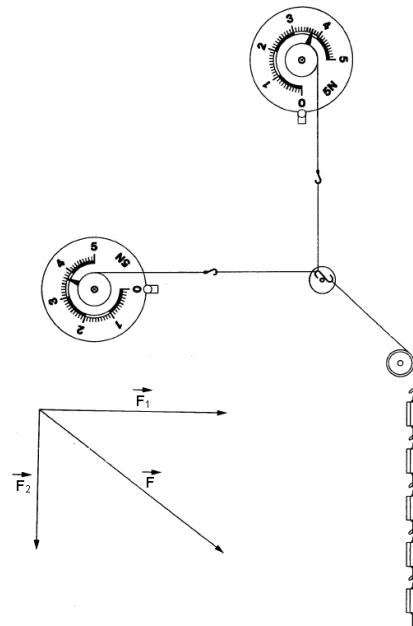

Fig. 8

Experiment procedure

The hooked weights exert a force on the brass hook, pointing diagonal downward. This force can be resolved into two perpendicular components. One force acts vertical the other horizontal. Both forces shown on the dynamometer are the counterpoises to the two components of the resolved force.

- Draw first the amount and direction of the diagonal downward directed force F of the hooked weights into the parallelogram of forces.
- From the starting point of this force a horizontal and a vertical line are then drawn.
- Now construct the parallelogram so that the force exerted by the hooked weights is the diagonal in the rectangle.

The amounts of both part forces starting from the point of application can be read from the parallelogram. These amounts correspond to those shown on the dynamometers. The direction of the part forces acting on the dynamometers is opposite though to these part forces since these are the counterpoises.

Result

Each force can be resolved into two forces perpendicular to each other. The amounts of those part forces correspond to the lengths of the two sides of the rectangle, where the resolved force forms the diagonal. Each of both part forces is smaller than the resolved one.

9. Resolution of a force into two parallel components

Equipment

1. 2 dynamometers
2. Lever
3. 4 hooked weights

Experimental set-up

- Position both dynamometers on the right and left part of the magnetic board at the same height.
- Attach the lever to the dynamometers so that the points of application of the force lie in each case in the last outside hole of the lever.
- Now change the positions of the dynamometers so that the forces act vertically upwards and the lever hangs horizontal.

The deflections on the dynamometers caused by the weight of the lever can be corrected by turning the scale disc.

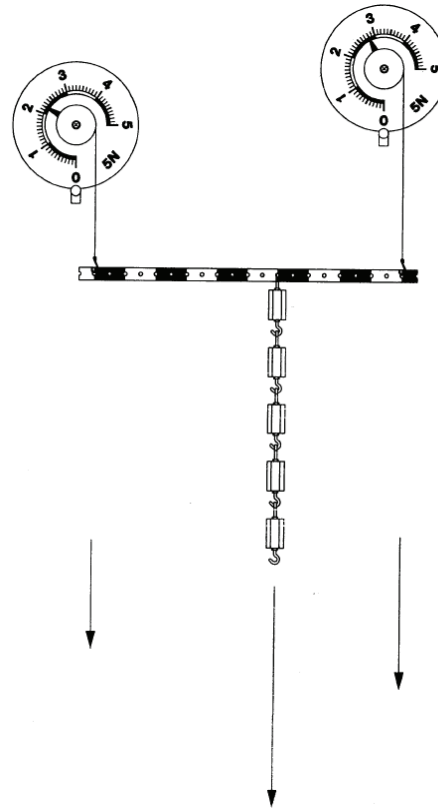

Fig. 9

Experiment procedure

- First determine the (equal) weight shown on both dynamometers.
- Then attach all 4 hooked weights in the middle of the lever and determine the part forces shown on the dynamometers.
- Then move the point of application gradually outwards and determine the part forces. Before the reading it is necessary to adjust the position of the dynamometers so that the lever is horizontal again.
- Enter the part forces F_1 and F_2 and the distances a_1 and a_2 into the table.

The sum of the part forces displayed on the dynamometers is equal to the weight of the hooked weights.

Table

Force F_1 in N	Force F_2 in N	Distance a_1 in cm	Distance a_2 in cm

Result

A force can be resolved into two part forces that act parallel to it. Thereby the sum of the amounts of the part forces is equal to the amount of the total force. The part forces act reciprocally to the distances of the points of application of the part forces from the point of application of the total force.

$$\frac{F_1}{F_2} = \frac{a_2}{a_1}$$

10. Gravity lines and centre of gravity of a plastic plate

Equipment

1. Centre of gravity plate
2. Plumb
3. Anchor post
4. Rubber grommet

Experimental set-up

- Position the anchor post in the middle of the upper half of the board and attach the plate to it at any of the drill holes.
- Mount the plumb on the anchor post and secure it with the rubber grommet.

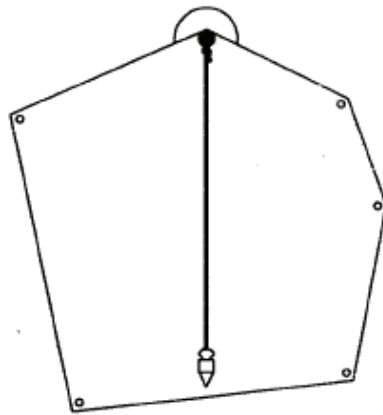

Fig. 10

Experiment procedure

- Draw a thin line with a pencil along the plumb line.
- Then attach the centre of gravity plate at one of the other drill holes, mount the plumb on the anchor post and draw another pencil line along the plumb line.
- Proceed in the same way with the other holes of the plate.

Result

All so-called gravity lines intersect in the same point. This is the centre of gravity of the plastic plate.

- To prove this dismount the plate from the anchor post, bring it in a horizontal position and balance it in the centre of gravity on a pointed pencil.

The plate does not change its position.

Notes

In the strict sense the centre of gravity is in the inner part of the plate. Therefore the balanced plate does not stay not at rest in every position.

11. States of equilibrium of a hanging body

Equipment

1. Lever
2. Steel rod, threaded
3. Anchor post
4. Rubber grommet

Experimental set-up

- Position the anchor post in the middle of the upper half of the board and attach the lever at its middle hole and secure it with the rubber grommet.

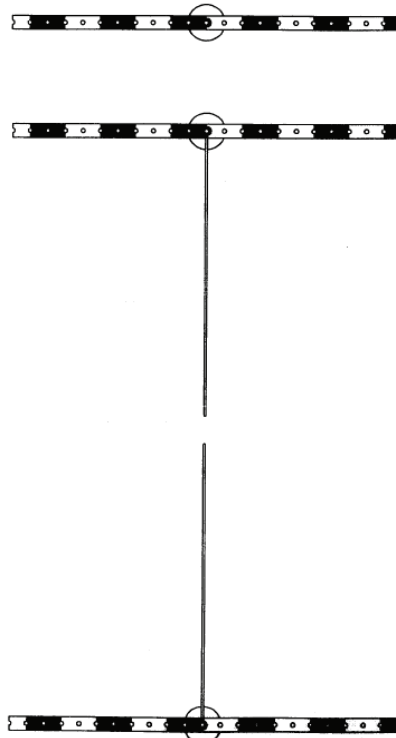

Fig. 11

Experiment procedure

- Bring the lever in different positions and release it.
- Then mount the steel rod pointing downwards in the middle part of the lever.
- Bring the lever again in different positions and release it – with the steel rod hanging below the fulcrum.
- Finally turn the lever 180° so that the steel rod points vertically upwards.
- Release the lever also in this position.

Result

In the first case the lever is in a state of neutral equilibrium. It will stay at rest in every position it is brought to.

In the second case the lever is in a state of stable equilibrium. Moving the lever from this state it will always return to it.

In the third case the lever is in a state of unstable equilibrium. It will stay in this position only for a short time. Any small deviation from this position will bring it into its state of stable equilibrium.

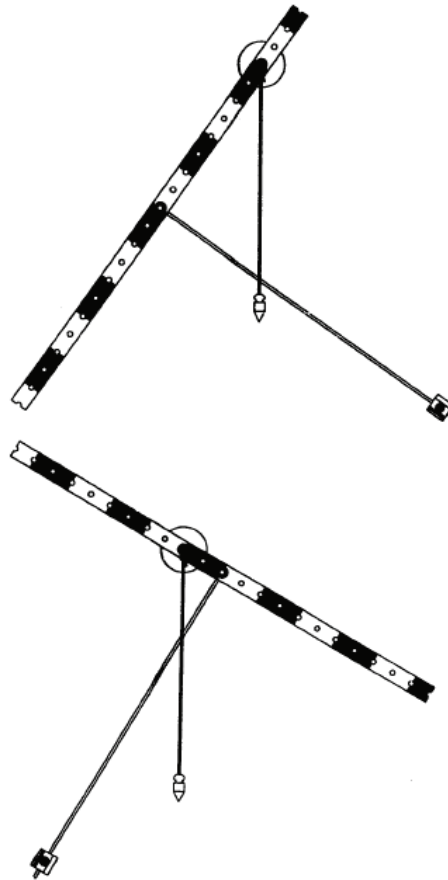

Fig.12

12. States of equilibrium – centre of gravity outside the lever

Equipment

1. Lever
2. Steel rod, threaded
3. Counter weight with knurled screw
4. Plumb line
5. Anchor post
6. Rubber grommet

Experimental set-up

- Screw the steel rod in the middle of the lever.
- Mount the counter weight with the knurled screw near the lower end of the rod.
- Position the anchor post in the middle of the upper half on the board and attach the plumb at the base plate of the anchor post.
- Put the lever on the anchor post at any hole and lock it with the rubber grommet.

Experiment procedure

- Mark the point where the plumb line intersects the rod e.g. with a piece of tape.
- Then attach the lever at another hole to the anchor post and determine the point of intersection of the plumb line and the rod.
- Repeat the experiment with two other holes on the other side of the lever from the viewpoint of the rod.
- Finally remove the lever and the plumb from the anchor post and balance the rod on a fingertip at the marked point.

Result

In all cases the point of intersection of the plumb line and the rod is in the same position. This point lies outside the lever. It is the centre of gravity of this set-up.

13. Equilibrium of forces at the two-sided lever

Equipment

1. 6 hooked weights

2. Lever
3. Steel rod, threaded
4. Counter weight with knurled screw
5. Anchor post
6. Rubber grommet
7. Magnetic triangle

Experimental set-up

- Position the anchor post in the middle of the upper half of the board, attach the lever at its middle hole to the anchor post and secure it with the rubber grommet against sliding down.
- Screw the rod into the lever below the anchor post and fix the counter weight with knurled screw in the middle of the rod.

The higher the position of the counter mass is mounted the higher is the sensitivity of the lever.

- Mark the fulcrum of the lever with the magnetic triangle.

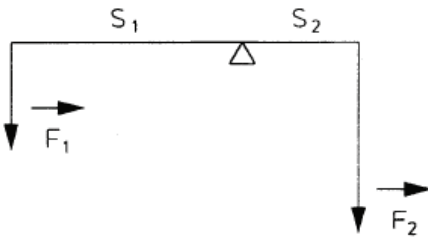
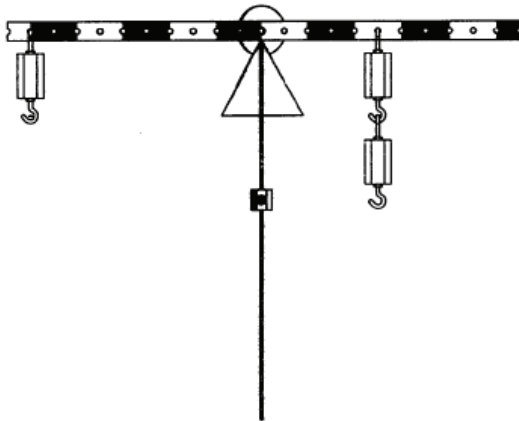

Fig. 13

Experiment procedure

- Hang one hooked weight in the left outer hole.
- Then choose the hole on the right side of the lever, where a hooked weight has to be attached so that the lever is in equilibrium.
- The points on which the forces act upon can be marked with the arrows.

- The distances between the two points of application and the fulcrum have to be measured and entered into the table, as well as the weight of the two hooked weights.
- After that hang a second hooked weight on the right one and look for the hole to reach equilibrium again.
- Enter the forces and the distances into the table.
- Now hang the left hooked weight two holes inwards (8th hole from the fulcrum).
- To establish equilibrium again, put first one, then two and finally four hooked weights in the appropriate position on the right side.
- Enter the lengths of the lever arms and amounts of forces into the table.

Table

Left lever arm s_1 in cm	Force acting on the left side F_1 in N	Right lever arm s_2 in cm	Force acting on the right side F_2 in N	$F_1 \cdot s_1$ in Ncm	$F_2 \cdot s_2$ in Ncm

Result

The further away from the fulcrum of a lever the force acts the smaller it has to be to establish equilibrium. For the mathematical analysis form the product of the force and the length of the lever arm for both sides of the lever (last two columns of the table).

$F_1 \cdot s_1 = F_2 \cdot s_2$ applies.

14. Equilibrium of forces at the one-sided lever

Equipment

1. Dynamometer
2. 6 hooked weights
3. Lever
4. Anchor post
5. Rubber grommet
6. Magnetic triangle

Experimental set-up

- Position the anchor post in the middle of the upper half of the magnetic board.

- Mount the lever (last hole on the left side) on the anchor post and hang the measuring part of the dynamometer into the last hole on the right side.
- Position the dynamometer in such a way that the lever gets in a horizontal position and the action line of the force runs perpendicular downwards.

The deflection on the dynamometer caused by the own weight of the lever can be corrected by turning the scale disc so that the pointer is on zero.

- Mark the fulcrum of the lever with the triangle.

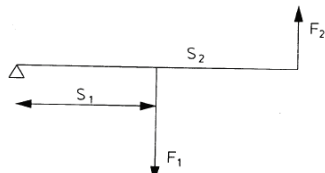
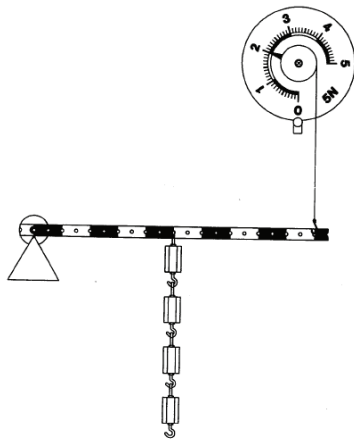

Fig. 14

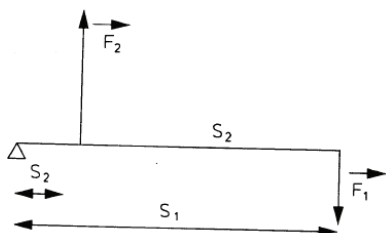
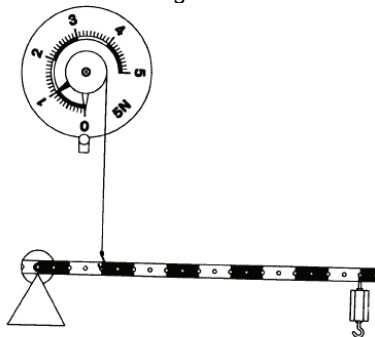

Fig. 14 a

Experiment procedure

- Attach 4 hooked weights to each other and hang them to the lever at a position about half the length of the lever.
- Enter the lengths of the lever arms and the values of the forces into the table.
- First hang the hooked weights in a hole near the fulcrum then to a hole further away. Again enter the physical quantities into the table.
- Detach the dynamometer from the lever and hang it in the 4th hole counted from the fulcrum.
- Adjust the dynamometer so that the lever is horizontal and the action line perpendicular upwards.
- Perform a zero-point calibration of the dynamometer again.
- Now attach one hooked weight successively at three positions to the right from the measuring point of the force.
- Enter the measured physical quantities into the table.

Table

Lever arm s_1 in cm	Force acting down- wards F_1 in N	Lever arm s_2 in cm	Force acting up- wards F_2 in N	$F_1 \cdot s_1$ in Ncm	$F_2 \cdot s_2$ in Ncm

Result

The greater the distance is between the point of application of the force and the fulcrum the smaller is the force to establish equilibrium.

For the mathematical analysis form the products of the lengths of the lever arms and the respective forces (last two columns of the table). For the one-side lever

$$F_1 \cdot s_1 = F_2 \cdot s_2 \text{ applies.}$$

15. Torque

Equipment

1. 2 dynamometers
2. Lever
3. Anchor post
4. Rubber grommet
5. Magnetic triangle

Experimental set-up

- Position the anchor post in the middle of the magnetic board.
- Mount the lever with its middle hole on the anchor post and secure it with the rubber grommet against sliding down.
- Put one dynamometer above the right arm of the lever the other one below the lever.
- Mark the fulcrum of the lever with the triangle.

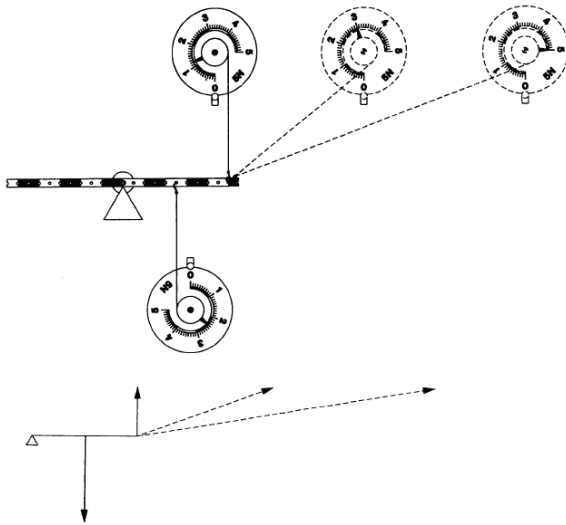

Fig. 15

Experiment procedure

- First hook the measuring point of the upper dynamometer in the last hole of the lever.
- Connect the lower dynamometer to the 5th hole from the fulcrum.
- Change the positions of the dynamometers so that the lever is in a horizontal position and the strings point perpendicularly up-resp. downward.
- While doing this, set on one dynamometer a force of a few Newton.
- Enter the respective distances between the points of application of the forces and the fulcrum of the lever and the corresponding forces into the table.
- Then first vary the point of application of the lower dynamometer twice, finally also the point of application of the upper dynamometer.
- In all cases adjust the lever to a horizontal position and pay attention to the forces acting perpendicularly.
- Enter again the distances from the fulcrum and the corresponding forces into the table.

- Finally change the position of the lower dynamometer in such a way that the direction of the force deviates more and more from the perpendicular. Take care to keep the lever in a horizontal position.

Table

Distance F_1 to fulcrum s_1 in cm	Force 1 F_1 in N	Distance F_2 to fulcrum s_2 in cm	Force 2 F_2 in N	Torque 1 $F_1 \cdot s_1$ in Ncm	Torque 2 $F_2 \cdot s_2$ in Ncm

Result

To describe the equilibrium of a pivoted body the torque can be used. It is the product of the distance from the point of application of the force to the fulcrum and the perpendicular acting force. In case of equilibrium the amount of the right-turning torque is equal to the amount of the left-turning torque

$$F_1 \cdot s_1 = F_2 \cdot s_2$$

The more the force deviates from the direction perpendicular to the lever, the stronger it has to be to keep the system in equilibrium. This result shows, that it is appropriate to define the torque as the product of the distance from the point of application of the force to the fulcrum and the force acting perpendicular to it. The more the force deviates from this direction, the greater its amount has to be so that the torque will be the same.

16. Forces at the fixed pulley

Equipment

1. 6 hooked weights
2. Large pulley
3. Anchor post
4. Rubber grommet
5. Magnetic scale
6. String with nooses

Experimental set-up

- Position the magnetic scale vertically on the board.

- Mount the big pulley in the middle of the upper end of the scale.
- Put the string over the pulley and hang one hooked weight in each noose.

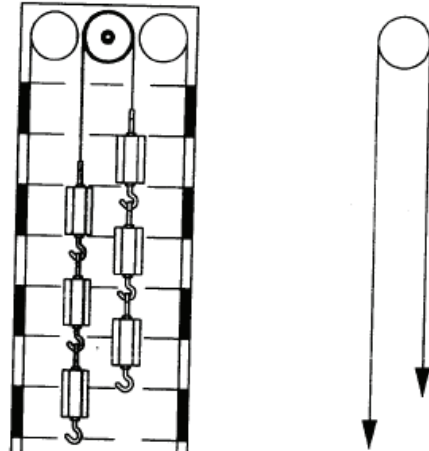

Fig. 16

Experiment procedure

- Raise the number of the hooked weights first to two then to three.
- In all cases bring the hooked weights in different positions and observe the behaviour of the whole set-up.

Result

Equilibrium is obtained when the same force is acting on both sides of the fixed pulley.

17. Forces at the loose pulley

Equipment

1. Dynamometer
2. Large pulley
3. Double pulley block
4. 6 hooked weights
5. Counter weight with knurled screw
6. Anchor post
7. Rubber grommet
8. Magnetic scale
9. String with nooses

Experimental set-up

- Position the magnetic scale vertically on the board.
- Mount the anchor post in the middle of the upper half of the scale.
- Put the large pulley close above.
- Attach one noose of the string to the anchor post and secure it with the rubber grommet.
- Hang the movable block with two pulleys on the string and let it run upwards over the fixed pulley at the upper end of the magnetic scale.
- Attach one hooked weight in the noose at the end of the string and two hooked weights to the movable block.
- To compensate the weight of the movable block also attach the counter weight with knurled screw to the hooked weight and add some plasticine if needed.

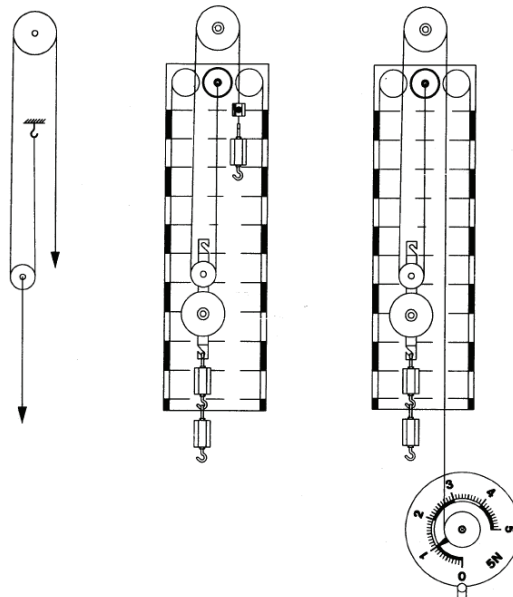

Fig. 17

Fig. 17 a

Fig. 17 b

Experiment procedure 1

- Move the hooked weight along the magnetic scale into different positions and release it.
- Then attach a second hooked weight to the movable block and more hooked weights to the noose to obtain the state of equilibrium.

Experiment procedure 2

- Replace of the hooked weight with a dynamometer and attach its measuring point to the noose where the hooked weight and the counter weight with knurled screw were hanging before.

- Remove the hooked weights from the movable block.
- First perform a zero-point calibration of the dynamometer by turning its scale disc to compensate the weight of the block.
- Then attach the hooked weights one after the other to the movable block and determine the respective forces shown on the dynamometer.

Result

The loose pulley is in a state of equilibrium when the force on the string is half of the force on the pulley.

Note

To perform the experiment it is advisable to remove the large pulley from the block for reasons of clarity and to reduce the weight of the block.

18. Forces at the block and tackle

Equipment

1. 6 hooked weights
2. Small pulley
3. Large pulley
4. Double pulley block
5. Counter weight with knurled screw
6. Anchor post
7. Rubber grommet
8. Magnetic scale
9. Long string with nooses

Experimental set-up

- Position the magnetic scale vertically on the board.
- Mount the large pulley above the scale, the small pulley below the large one and further below the anchor post.
- Attach one noose of the string to the anchor post and secure it with the rubber grommet.
- Pass the string over the small pulley of the movable block, with the small pulley pointing upwards.
- Pass the string further up over the small pulley, then down again over the large pulley of the movable block and finally up over the large pulley.
- Attach the counter weight with knurled screw and if needed some plasticine to compensate the weight of the movable block.

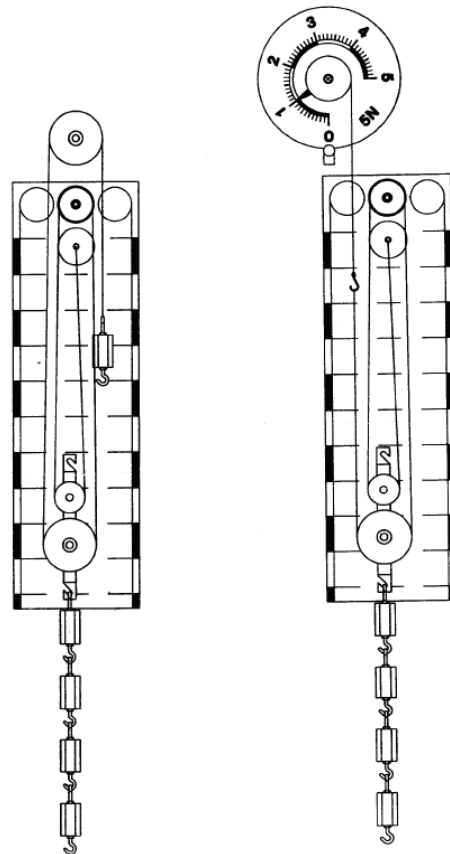

Fig. 18

Fig. 18 a

Experiment procedure

- Attach a hooked weight to the free noose.
- Hang as many hooked weights to the movable block as needed to obtain a state of equilibrium of the block and tackle system.

By moving the block up and down you can check if the block and tackle is in equilibrium in every position.

Result

The block and tackle with 4 pulleys is in a state of equilibrium when the force at the block is 4 times bigger than the force at the end of the string.

Notes

Instead of the upper large pulley a dynamometer can be used (Fig. 18b). It should be positioned at about the same place as the large pulley on the upper end of the magnetic board. In this case the weight of the movable block has to be compensated by a zero-point calibration of the dynamometer. With the attachment of each additional hooked weight the force shown increases by 0.25 N.

19. Forces at the inclined plane – study with the dynamometer

Equipment

1. Dynamometer
2. Inclined plane
3. Hooked roller
4. Lever
5. 2 anchor posts
6. Plumb line
7. 2 rubber grommets
8. String with nooses

Experimental set-up

- Position the inclined plane on the magnetic board and attach the plumb to the upper part of the protractor.
- Adjust the angle to the horizontal first to 10°.
- Put the hooked roller on the surface so that it is close to the board.
- Hang the roller in one noose of the string, which runs over the pulley vertically downwards to the dynamometer.
- Position the lever horizontally underneath the inclined plane on two anchor posts in the 5th and 10th holes from the left lower end of the inclined plane and secure it with rubber grommets.

In this way the height of the inclined plane can be determined as the vertical distance from the horizontal lever to the right lower end of the inclined plane.

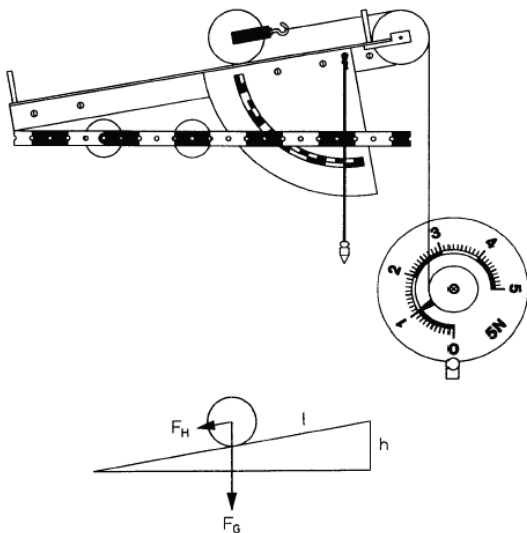

Fig. 19

Experiment procedure

- Gradually increase the angle between the inclined plane and the horizontal from 10° to 40°.
- Measure the heights of the inclined plane and the corresponding parallel forces shown on the dynamometer and enter the values into the table.

Table

Height h cm	Length l in cm	Parallel force F_H in N	Weight of roller F_G in N	$\frac{h}{l}$	$\frac{F_H}{F_G}$

Result

The more the height of the inclined plane is increased the greater is the parallel force. For the mathematical analysis form the quotients of the parallel force F_H and the weight F_G as well as of height h and length l of the inclined plane (last two columns of the table). The comparison of the quotients shows that

$$\frac{F_H}{F_G} = \frac{h}{l} \text{ applies.}$$

Notes

1. The string between the roller and the dynamometer can run horizontally behind the pulley or in any other angle. The only requirement is that it should run parallel to the inclined plane near the roller. The set-up is very clear when the string runs parallel to the inclined plane from the roller to the dynamometer. However with every change of the angle the position of the dynamometer has to be changed too.
2. The state of equilibrium on the inclined plane can be obtained by attaching weights of the same amount as the parallel force to the end of the string instead of the dynamometer.
3. If the mathematical preconditions are fulfilled, the angle can be used in the analysis instead of the height and the length

$$(F_H = F_G \cdot \sin \alpha).$$

20. Forces at an inclined plane – study with the hooked weights

Equipment

1. Inclined plane
2. Hooked roller
3. 4 hooked weights
4. Lever
5. 2 Anchor posts
6. Plumb line
7. 2 rubber grommets
8. String with nooses

Experimental set-up

- Position the inclined plane on the magnetic board and attach the plumb to the upper part of the protractor.
- First mount the inclined plane in horizontal position.
- Put the hooked roller on the surface so that it is close to the board.
- Hang the roller in one noose of the string, which runs over the pulley vertically downwards.
- Position the lever horizontally underneath the inclined plane on two anchor posts in the 5th and 10th holes from the left lower end of the inclined plane and secure it with rubber grommets.

In this way the height of the inclined plane can be determined as the vertical distance from the horizontal lever to the right lower end of the inclined plane.

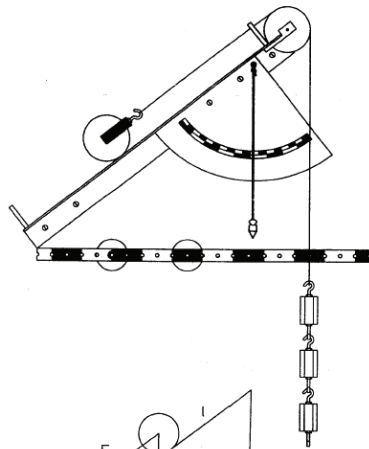

Fig. 20

Experiment procedure

- Attach one hooked weight to the second noose of the string.
- Hold the hooked roller first and increase the angle of the inclined plane so that the hooked weight compensates the parallel force of the hooked roller.
- Measure the height of the inclined plane and enter it with the length of the plane, the weight of the hooked roller and that of the downhill slope force into the table.
- After that attach two hooked weights to the noose and increase the angle till the weight of the hooked weights compensates the parallel force of the hooked roller.
- Repeat the experiment with 3 and 4 hooked weights.

Table

Height h in cm	Length l in cm	Parallel force F_H in N	Weight of hooked roller F_G in N	$\frac{h}{l}$	$\frac{F_H}{F_G}$

Result

The more the height of the inclined plane is increased the greater is the parallel force.

For the mathematical analysis form the quotients of the parallel force F_H and the weight F_G as well as of height h and length l of the inclined plane (last two columns of the table). The quotients are equal.

$$\frac{F_H}{F_G} = \frac{h}{l} \text{ applies.}$$

Notes

Instead of the hooked weights a very light and small weight pan can be used. Then the inclined plane can be set at any given angle. The parallel force can be determined by putting weights on the pan.

21. Dynamic friction - study with the dynamometer

Equipment

1. Dynamometer
2. Inclined plane
3. Aluminium friction block with two hooks
4. 6 hooked weights
5. String with nooses

Experimental set-up

- Position the inclined plane horizontally on the left side of the magnetic board.
- Put the friction block on the left end of the inclined plane with the largest side face down.
- Attach the string with nooses to one hook. The string should run parallel to the inclined plane over the fixed pulley.
- Connect the second noose to the measuring point of the dynamometer.

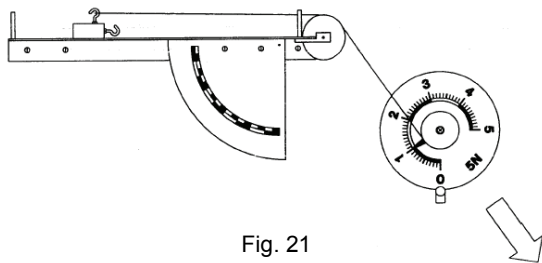

Fig. 21

Experiment procedure

- Shift the dynamometer slowly horizontally resp. diagonally downwards so that the friction block moves in a steady way.
- During this movement read the friction force from the dynamometer.
- Next put the block on its smaller side with the same surface texture and repeat the experiment.

By putting hooked weights on the block the effective weight can be increased gradually.

- After that put sheets of different materials on the inclined plane (e.g. wood, paper, plastic) and repeat the experiments in the same way.

Result

The dynamic friction is dependent on the characteristics of the two materials sliding on each other. It increases proportionally with the weight of the sliding body. It is independent from size of the sliding area.

Notes

The dynamic friction coefficient can be determined by forming the quotient of the dynamic friction force and the weight of the block. One narrow side of the block is coated with a rubber layer. The comparison of the forces of the equally large friction surfaces with different textures shows particularly clearly the dependence of the friction on the kind of the materials sliding one on the other.

22. Dynamic friction - study with weights

Equipment

1. Inclined plane
2. Aluminium friction block with 2 hooks
3. 2 hooked weights
4. Plumb line
5. String with nooses

Experimental set-up

- Position the inclined plane slightly tilted on the upper part of the magnetic board.
- Attach the plumb to the upper part of the protractor.
- Put the friction block on the left end of the inclined plane with the largest side face down.
- Attach the string with nooses to one hook. The string should run parallel to the inclined plane over the fixed pulley.
- Attach a hooked weight to the free noose of the string.

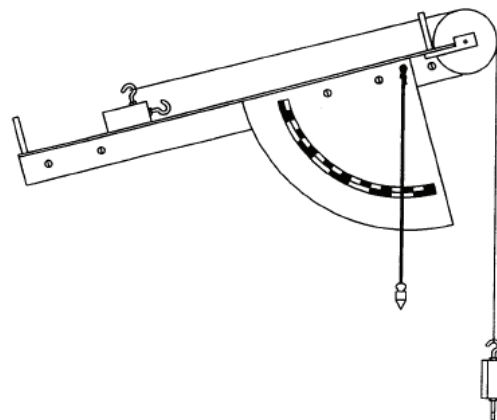

Fig. 22

Experiment procedure

- Decrease the slope of the plane so that the friction block slides with constant speed after a slight push.
- As a measure for the needed force the slope of the plane has to be determined.
- Repeat the experiment in the same way after putting the block on one of its smaller sides.
- Finally increase the force with which the block is pressing onto the inclined plane by gradually putting hooked weights on it.
- Repeat the experiments after putting sheets of different materials (e.g. wood, paper, plastic) on the inclined plane.

Result

The dynamic friction increases proportionally with the weight of the sliding body. It is dependent on the characteristics of the two materials sliding on each other. The dynamic friction is independent from the size of the sliding area.

Notes

1. The force of dynamic friction can be determined by finding out how flat the slope should be so that the hooked weight pulls the block up the plane. It can also be determined by setting the plane gradually steeper and measure the angle at which the friction block pulls the hooked weight upwards.
2. It is also possible to do the experiment without the string and the hooked weight. Put the block on the upper end of the inclined plane and increase its slope until the block, after a slight push, slides down the plane at a constant speed.
3. By changing the slope of the inclined plane the force with which the body presses perpendicular on the surface changes too. Only in the case of a horizontal plane is it equal to the weight. This force decreases with an increase of the slope. For the analysis though it is assumed that the force is constant. Therefore in this experiment only an estimation of the dependence of the friction force is carried out.

23. Static friction

Equipment

1. Dynamometer
2. Inclined plane
3. Aluminium friction block with 2 hooks
4. 6 hooked weights
5. String with nooses

Experimental set-up

- Position the inclined plane horizontally on the left side in the upper half of the board.
- Put the friction block on the left end of the inclined plane.
- Attach the string to one of the hooks and let it run it over the fixed pulley so that it is nearly parallel to the inclined plane.
- Attach the other end of the string to the measuring point of the dynamometer.

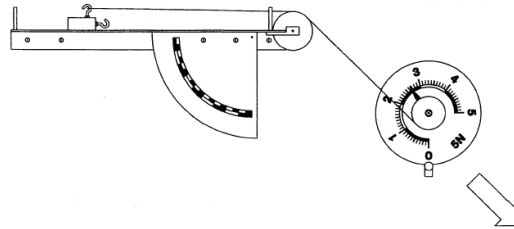

Fig. 23

Experiment procedure

- Shift the dynamometer slowly diagonally to the right downward. Thereby determine the force, which is needed to actuate the friction block.
- Repeat the experiment after putting the block on one of its small sides.
- Finally put sheets of different materials (e.g. wood, metal, paper, plastic) on the surface and repeat the experiment.
- After that gradually load the friction block with hooked weights and determine the respective forces for actuation.

Result

The static friction is dependent on the kind of surfaces sliding on each other. It increases proportional to the force of the pressure. At constant pressure the static friction is the higher the larger the sliding surface is.

In all cases the static friction is higher than the dynamic friction determined in experiment 21.

Notes

Instead of the dynamometer a hooked weight can be attached to the string. Conclusions about the amount of the frictional force are possible by tilting the inclined plane (cf. experiment 21). The experiment can be done without the string by increasing the slope of the inclined plane to such an extent that the friction block just starts to move. Refer to note 3 of experiment 22.

24. Roll friction

Equipment

1. Dynamometer
2. Inclined plane
3. Hooked roller
4. Aluminium friction block with 2 hooks
5. 3 hooked weights
6. String with nooses

Experimental set-up

- Position the inclined plane horizontally in the left upper part of the magnetic board.
- Put the hooked roller on the left end of the inclined plane and attach one end of the string to it.
- Run the string over the fixed pulley and attach it to the dynamometer, which is on the right side below the inclined plane.

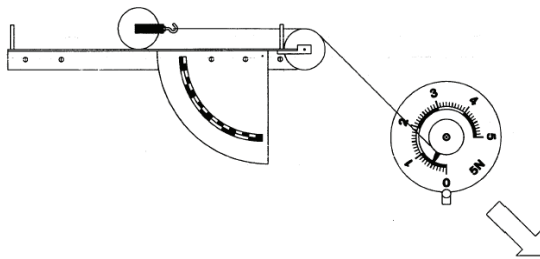

Fig. 24

Experiment procedure

- Shift the dynamometer slowly to the right downward. Thereby determine the force, which is needed to keep the hooked roller moving.
- Then replace the hooked roller by the block loaded with three hooked weights. Its weight equals that of the hooked roller.
- With this procedure determine the force, which is needed to keep the block moving at a constant speed.

Result

Compared to the dynamic and static friction the roll friction is much smaller.

25. Period length of a string pendulum

Equipment

1. 3 hooked weights
2. Anchor post
3. Rubber grommet

4. Brass clip
5. Magnetic scale
6. String with nooses, long
7. Stop watch

Experimental set-up

- Position the magnetic scale vertically on the board.
- Mount the anchor post with a rubber grommet on the middle circle on the upper end of the scale.
- Put the brass clip over the anchor post.
- Hook the nooses of the string onto each end and hang one hooked weight on the string.

The length can be read directly from the scale. The active upper end of the pendulum is in the middle of the brass clip at the beginning of the scale, the lower end in the middle of the weight.

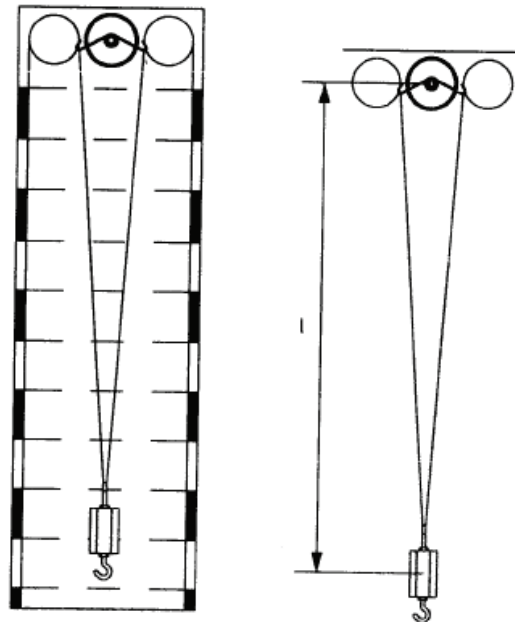

Fig. 25

Experiment procedure 1

Relation between period length and mass of the string pendulum

- Deflect the weight to the edge of the scale and release it.
- Determine the time for 10 periods with the stop watch and enter it into the table.
- Then instead of one hooked weight attach two, finally three hooked weights next to each other on the string.
- Determine the time for 10 periods for each case.

- Repeat the experiments with a different pendulum length (string of another length).

Table

Length <i>l</i> in cm	Mass <i>m</i> in g	Time of 10 periods <i>t</i> in s	Period length <i>T</i> in s

Result

The period length of a string pendulum is not dependent on the mass.

Experiment procedure 2

Relation between period length and pendulum length

The pendulum mass is a hooked weight.

- The pendulum length should be about 50 cm.
- Deflect the hooked weight to the edge of the scale and release it. Determine the time for 10 periods and enter it to the table.
- Decrease the pendulum length to 40 cm and attach the string with an easily detachable noose to the one side of the brass clip.
- Determine the time of 10 periods again and enter it to the table.
- Then decrease the pendulum length gradually.
- Calculate the period length from the time for 10 periods.
- Finally calculate the square of the period length and enter it into the last column of the table.

Table

Length <i>l</i> in cm	Time of 10 periods <i>t</i> in s	Period length <i>T</i> in s	Square of period length <i>T</i> ² in s ²

Result

The longer the pendulum the longer is the period. $T^2 \sim l$ applies.

Notes

- In the first experiment the centre of gravity shifts slightly upwards because two or more hooked weights are hanging next to each other. To make sure that the pendulum length stays unchanged from experiment to experiment put a small piece of wire if necessary (e.g. paperclip) between string and pendulum body.
- The second experiment can be used to confirm the equation for the period time of a string pendulum

$$T = 2\pi \sqrt{\frac{l}{g}}$$

Using the pendulum length *l* and the acceleration of fall *g* the period length can be determined. For each part experiment it is equal to the measured period length.

26. Spring oscillator

Equipment

- 3 hooked weights
- 3 springs
- Anchor post
- Rubber grommet
- Magnetic scale
- Stop watch

Experimental set-up

- Position the magnetic scale vertically on the board and attach the anchor post to the upper end.
- Add the spring and secure it with the rubber grommet.

- Hang a hooked weight to the lower end of the spring.

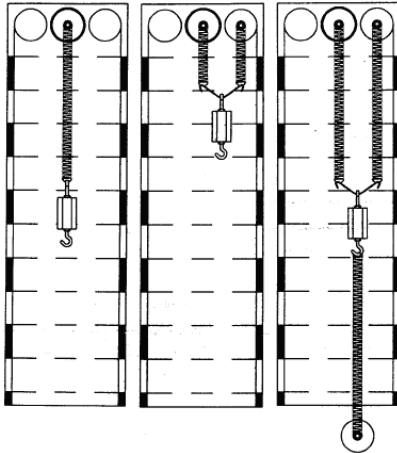

Fig. 26 a

Fig. 26 b

Experiment procedure 1

Relation between period length and mass of the spring oscillator

- Move the hooked weight about 5 cm vertically downwards and release it.
- Determine the time for 10 periods with the stop watch and enter it into the table.
- Then attach consecutively 2 and 3 hooked weights to the spring.
- Enter the times for 10 periods into the table.
- Plot the square of the period length as a function of the mass.

Table

Mass m in g	Time of 10 periods t in s	Period length T in s	Square of period length T^2 in s ²

Result

The period length of a spring oscillator increases with the mass. $T^2 \sim m$ applies.

Experiment procedure 2

Relation between period length and spring constant

- First hang one spring on the anchor post and determine the position of the lower end.
- Then attach one hooked weight to the spring and determine the extension.
- After that suspend two springs hanging below each other from the anchor post and again determine their extension by hanging one hooked weight on them.
- Repeat the experiment with 3 springs.
- Form the quotient of expansion and the acting force for all three cases and enter them into the table.
- In the case of one spring with hooked weight the extension is about 5 cm. Release it and determine the time for 10 periods.
- Repeat the experiment with the other two set-ups (2 and 3 springs).
- Enter the times into the table.
- Plot the square of the period length as a function of the quotient of the extension and the force.

Table

Number of spring s	Force F in N	Spring constant k in N/cm	Time of 10 periods t in s	Period length T in s	Extension l in cm
1	100				
2	100				
3	100				

Result

The quotient of force and expansion of a spring characterises its stiffness (spring constant $k = \frac{F}{l}$). The larger the spring constant the shorter is the period length.

$$T^2 \sim \frac{l}{k} \text{ applies.}$$

Notes

- With an exact determination of the proportionality between T^2 and l/k the weight of the springs and the corresponding extension are to be taken into account.
- In experiment 2 a few springs can be set up next to each other. This decreases the spring constant. This set-up can easily be achieved by

attaching two anchor posts next to each other where each one of the springs is suspended. Connect the lower end of both springs with the brass clip, where you can attach the hooked weights (refer to figure 26 a).

3. Both experiments can be used to confirm the equation for the period length of a spring oscillator

$$T = 2\pi\sqrt{\frac{m}{k}}$$

In this case enter mass m and spring constant k into the equation and calculate the period length. For each part experiment it is equal to the measured period length.

4. The spring constant can be changed by hanging a coil spring to the lower hook of the hooked weight, and attaching its lower end to an additional anchor post (refer to figure 26 b).

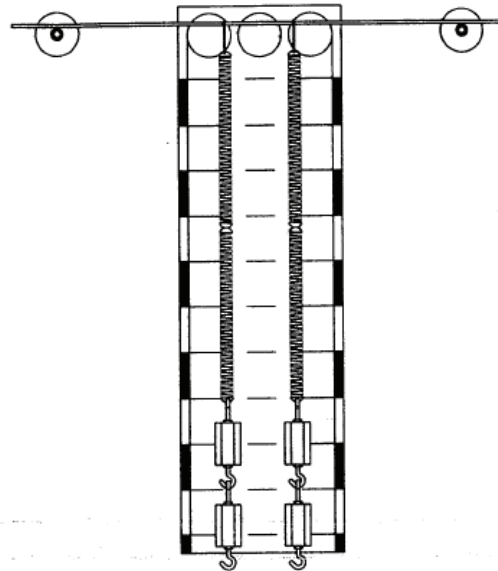

Fig.27

27. Resonance of two spring oscillators

Equipment

1. 4 hooked weights
2. Lever
3. 2 coil springs
4. 2 anchor posts
5. 2 rubber grommets
6. Magnetic scale
7. 2 brass hooks

Experimental set-up

- Position the magnetic scale vertically on the board and attach the anchor posts on the left and right side in the height of the upper end of the scale.
- Secure them with rubber grommets and put the lever over them in a way that almost the whole length of the lever can be used.
- Using the brass hooks hang the two coil springs loaded each with two hooked weights in the middle of the lever with a distance of two holes between them.

Experiment procedure

- Move the lower end of one of the springs about 5 cm vertically downwards and release it.

During swinging this spring transmits its energy to the other oscillator, which starts to swing with steadily increasing amplitude.

Finally the first oscillator comes to rest. Then the energy is transmitted back to the first oscillator.

Result

With coupled oscillators of the same natural frequency, repeated total energy transmission takes place from one oscillator to the other.

Two extenders are added to this kit. If the set is too close to the white board, you can add the plastic extenders to the inclined plane. Unscrew the magnets and add the extenders.