

产品特性

- 通道个数：8通道
- 频率范围：2400-2483.5Mhz
- 供电范围：4.5-8.4V
- 信号格式：D8
- 输出格式：PWM
- 支持回传：支持回传RSSI
- 控制距离：大于1km
- 天线长度：15厘米
- 尺寸：40*26*16毫米
- 重量：11克

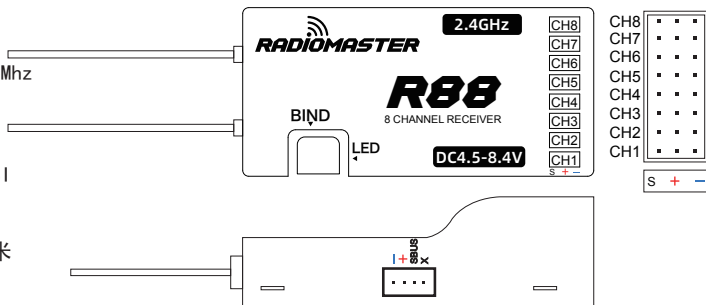

对频方法

1. 接收机按住BIND按钮，同时接通电源，约等待3秒后接收机LED红灯常亮，等待对频
2. 遥控器多协议高频头选择D8协议，并按下[BIND]选项，接收机红灯闪烁，表示对频成功
3. 遥控器退出[BIND]模式，接收机需重新通电，此时接收机红灯常亮，对频成功

失控保护

1. 接收机通电10秒内，按一次BIND按钮，接收机将保存遥控器当前所有通道值，作为失控保值
2. 接收机通电10秒之后，BIND按钮功能将被停用，以防止飞行时误触更改失控保护设置

RSSI输出

此接收机S-BUS输出共计9个通道，为8通道+RSSI输出通道，1-8通道来自遥控器的控制，第9通道是接收机自身输出的信号强度RSSI值，可由飞控读取并发送至OSD设备显示信号强度

频率微调

特别注意 D8和D16协议接收机在正式使用之前，必须使用频率微调功能，消除发射机与接收机之间的频率误差，才可达到最佳遥控距离与稳定性，具体操作方法如下：

1. 将RF Freq. fine tune数值逐渐调低，直到接收机丢失信号，并记录下这个数值（一般为负数）
2. 再RF Freq. fine tune数值逐渐调高，直到接收机丢失信号，并记录下这个数值（一般为正数）
3. 将这两个数字按此公式计算，得出频率微调中点值，并填写在RF Freq. fine tune参数中
(低位数值+高位数值) ÷ 2 = 中点值

例如：得到低位数值为-73，高位数值为35，根据公式计算

$$\text{RF Freq. fine tune} = (-73 + 35) \div 2$$

$$\text{RF Freq. fine tune} = (-38) \div 2$$

$$\text{RF Freq. fine tune} = -19$$

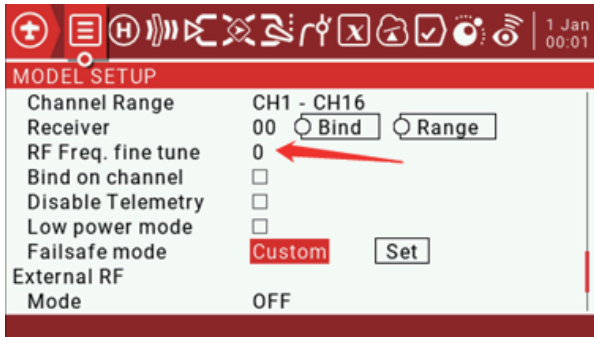

Receiver Specifications

Channels: 8
 Frequency range: 2400-2483.5Mhz
 Power input range: 4.5-8.4V
 Signal format: D8
 Output format: PWM
 Support return: support return RSSI
 Range: more than 1km
 Antenna length:15cn
 Size: 40*26*16mm
 Weight:11g

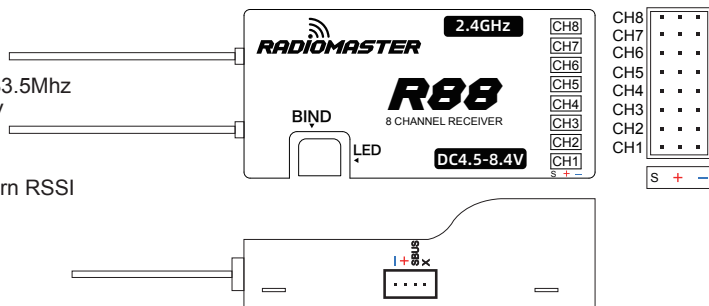

Bind Method

1. Press and hold the BIND button on the receiver then connect power. After approximately 3 seconds, the receiver LED will be RED, the receiver is now in bind mode.
2. Select the D8 protocol for the multi-protocol menu of your remote control, and press the [BIND] option, the red light of the receiver will flash indicating successful bind.
3. Exit bind mode on your remote control and disconnect power to the receiver then power the receiver once more. The LED will now be solid RED indicated the bind is now done. If not please repeat step 1 and 2.

Fail-safe Protection

1. Press the BIND button once within 10 seconds of the receiver being powered on, and the receiver will save all the current channel values of the remote control as the fail-safe value.
2. 10 seconds after the receiver is powered on, the BIND button function will be disabled to prevent accidental changes to the fail-safe settings while preparing the model for flight.

RSSI output

This receiver has a total of 8 PWM channels + 9 SBUS Channels (Sbus has 8 control channels + 1 RSSI channel). Channels 1-8 are controlled by the remote controller, the 9th channel is the signal strength RSSI value output by the receiver, which can be read by various flight controllers and sent to the OSD to Show signal strength in the FPV video feed.

D8 and D16 compatible receivers MUST be frequency fine tuned before flight.

Once the radio is bound to the receiver:

Return to the RF Freq. fine tune option

1. Lower the value until the radio loses the connection with the receiver. Record the value (TUNE_MIN).
2. Raise the value so that the connection is restored, then continue to raise it until the radio loses the connection with the receiver again. Record the value (TUNE_MAX).
3. Calculate the median between the two values $(TUNE_MIN + TUNE_MAX) / 2 = TUNE_MEDIAN$
4. Set RF Freq. fine tune to the median value

Example

Connection is lost at -73 and +35; the median is -19:

Once the Fine Tuning value is known, it can be used for all models which use the same protocol.

For More information visit <https://www.multi-module.org/using-the-module/frequency-tuning>

