

TOOLS NEEDED TO INSTALL DROPOUT SPICE RACK/STORAGE SYSTEM – 8002

#2 PHILLIPS SCREW DRIVER

#1 SQUARE DRIVE

3/16" HEX DRIVER WITH 9" MINIMUM EXTENSION (attached to back of unit), CONNECTED TO A POWER SCREW DRIVER OR RACHET

TAPE MEASURE

PENCIL

PILOT DRILL (THE SIZE OF DRILL IS DEPENDENT ON CABINET MATERIAL)

DESIGN CONSIDERATIONS FOR PLACEMENT OF UNIT

Do not install open side of this unit any closer than 4 ½" from an exhaust hood or nay other obstruction. **Always maintain a minimum of 4 ½" of access clearance!** This is to maintain adequate access to all the contents when racks are filled.

Do not mount door front (customer provided) completely adjacent to a wall or deep cabinet. It is recommended that there be a filler strip or panel (¾" minimum) between the corner and the door on the Dropout. **See drawing below.**

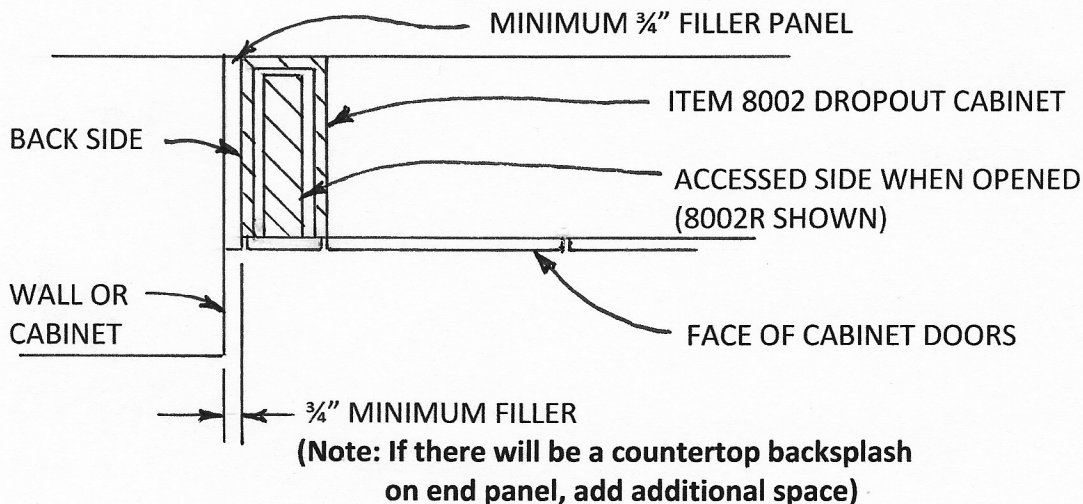

PLAN VIEW