

THC INSERT FLAT HEAD

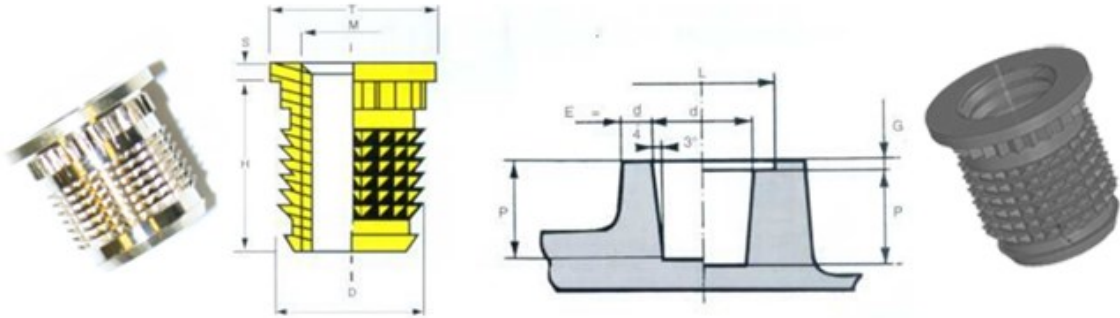

Insertion by THERMIC or
ULTRASONIC process
SERPLAST with collar – THC

All dimensions in mm
Material :- BRASS

| THREAD SIZE | LENGTH | | | | | | | | | PART NUMBER |
|-------------|--------|-----|-----|-----|------|------|-----|--------|--------|---------------|
| | | M | H | D | T | S | d | P mini | E mini | |
| M2 | 4 | 4 | 5 | 0.5 | 3.5 | 6.5 | 1 | 5.2 | 0.5 | 40/THC020H040 |
| M2.5 | 5 | 4 | 5 | 0.5 | 3.5 | 6.5 | 1 | 5.2 | 0.5 | 40/THC025H050 |
| M3 | 5.5 | 4.5 | 6 | 0.5 | 4 | 7 | 1.1 | 6.2 | 0.5 | 40/THC030H055 |
| M3.5 | 6 | 5.5 | 7 | 0.5 | 5 | 7.5 | 1.3 | 7.2 | 0.5 | 40/THC035H060 |
| M4 | 7.5 | 6 | 7.5 | 0.8 | 5.4 | 9 | 1.4 | 7.7 | 0.8 | 40/THC040H075 |
| M5 | 8 | 7 | 8 | 0.8 | 6.4 | 9.5 | 1.7 | 8.2 | 0.8 | 40/THC050H080 |
| M6 | 9 | 8.5 | 10 | 0.8 | 7.9 | 11 | 2 | 10.2 | 0.8 | 40/THC060H090 |
| M8 | 10 | 10 | 12 | 1 | 9.4 | 12 | 2.4 | 12.2 | 1 | 40/THC080H100 |
| M10 | 13 | 12 | 14 | 1 | 11.3 | 15.5 | 2.9 | 14.2 | 1 | 40/THC100H130 |

R.T.S. SALES LINE
01296 330331



For additional information and technical support please contact R.T.S. technical sales department . R.T.S. reserve the right to change specifications at any time . Information given is for guidance only and should not be used for specific design criteria without reference to our application engineers.