

SOCS-TYPE CBM IN STEEL

TECHNICAL DATA SHEET

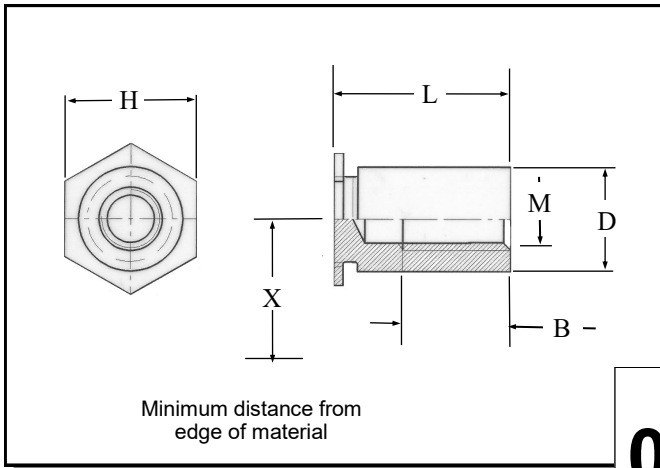

Standoff closed end Captive Nut in steel for thin sheet material

All dimensions in mm
 Material :- Steel 11 MnPb37
 Finish :- Zinc B/Fe Cr3

R.T.S. SALES LINE
01296 330331

THREAD SIZE "M"	HOLE SIZE +0.10	BODY "D"	HEAD "H"	MIN MAT "E"	MIN DIST "X"	PART NUMBER
M3 x 0.50	4.20	4.20	5.00	1.00	6.00	SOCS-03**-CBM1
M3 x 05.0	5.40	5.40	7.00	1.00	7.00	SOCS-03**-CBM2
M4 x 0.70	7.20	7.10	8.00	1.30	8.00	SOCS-04**-CBM
M5 x 0.80	7.20	7.10	8.00	1.30	8.00	SOCS-05**-CBM

THREAD SIZE "M"	ADD STANDARD AVAILABLE LENGTHS TO PART NUMBER **								
	08	10	12	14	16	18	20	22	
M3 x 0.50	08	10	12	14	16	18	20	22	
M3 x 0.50	08	10	12	14	16	18	20	22	
M4 x 0.70	08	10	12	14	16	18	20	22	
M5 x 0.80	08	10	12	14	16	18	20	22	
Thread length Min "B"	4.00	4.00	5.00	6.50	6.50	9.50	9.50	9.50	

For additional information and technical support please contact R.T.S. technical sales department . R.T.S. reserve the right to change specifications at any time . Information given is for guidance only and should not be used for specific design criteria without reference to our application engineers.