

DII- STAINLESS STEEL BLIND RIVETS

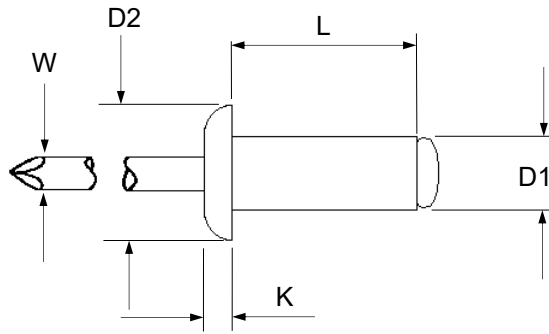

Dome headed stainless steel rivets for material up to 13.00 mm

All dimensions in mm.
Rivet body - Stainless Steel
Stem - Stainless Steel

R.T.S. SALES LINE
01296 330331

TECHNICAL DATA SHEET

BODY Ø D1	GRIP RANGE	LENGTH L	HEAD Ø D2	HEAD DEPTH K	DRILL SIZE	PART NUMBER
3.2	1.50 to 3.0	6.00	6.50	0.80	3.30	DII-3206-O
3.2	3.0 to 5.0	8.00	6.50	0.80	3.30	DII-3208-O
3.2	5.0 to 7.0	10.00	6.50	0.80	3.30	DII-3210-O
3.2	7.0 to 9.0	12.00	6.50	0.80	3.30	DII-3212-O
3.2	9.0 to 11.0	14.00	6.50	0.80	3.30	DII-3214-O
3.2	11.0 to 13.0	16.00	6.50	0.80	3.30	DII-3216-O
4.0	1.0 to 2.50	6.00	8.00	1.00	4.10	DII-4006-O
4.0	2.50 to 4.5	8.00	8.00	1.00	4.10	DII-4008-O
4.0	4.50 to 6.5	10.00	8.00	1.00	4.10	DII-4010-O
4.0	6.5 to 8.5	12.00	8.00	1.00	4.10	DII-4012-O
4.0	8.5 to 10.0	14.00	8.00	1.00	4.10	DII-4014-O
4.0	10.0 to 12.0	16.00	8.00	1.00	4.10	DII-4016-O
4.0	12.0 to 14.0	18.00	8.00	1.00	4.10	DII-4018-O
4.8	1.5 to 4.0	8.00	9.50	1.10	4.90	DII-4808-O
4.8	4.0 to 6.0	10.00	9.50	1.10	4.90	DII-4810-O
4.8	6.0 to 8.0	12.00	9.50	1.10	4.90	DII-4812-O
4.8	8.0 to 9.5	14.00	9.50	1.10	4.90	DII-4814-O
4.8	9.5 to 11.0	16.00	9.50	1.10	4.90	DII-4816-O
4.8	11.0 to 13.0	18.00	9.50	1.10	4.90	DII-4818-O
4.8	13 to 16.0	20.00	9.50	1.10	4.90	DII-4820-O
4.8	17 to 20.0	25.00	9.50	1.10	4.90	DII-4825-O
6.4	3.0 to 4.0	10.00	13.0	1.80	6.50	DII-6410-O
6.4	4.0 to 6.0	12.00	13.0	1.80	6.50	DII-6412-O

For additional information and technical support please contact R.T.S. technical sales department . R.T.S. reserve the right to change specifications at any time . Information given is for guidance only and should not be used for specific design criteria without reference to our application engineers.