

DAS- ALUMINIUM BLIND RIVETS

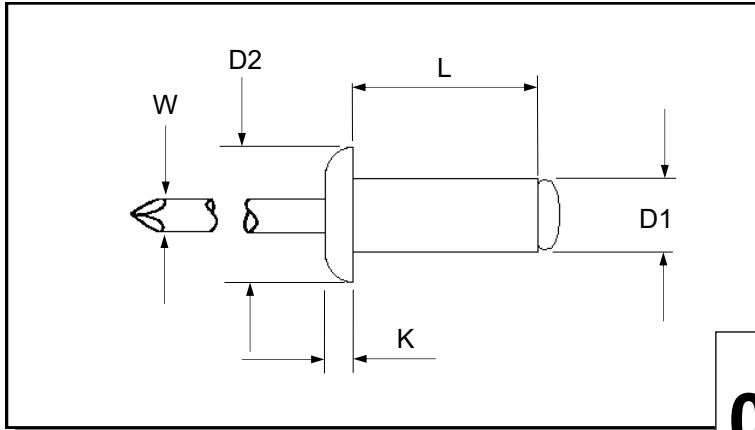

Dome headed Aluminium rivets
for material up to 30.00 mm

All dimensions in mm.
Rivet body - Aluminium
Stem - steel zinc plated

R.T.S. SALES LINE
01296 330331

TECHNICAL DATA SHEET

BODY Ø	GRIP	LENGTH	HEAD Ø	HEAD	DRILL	NAIL Ø	PART NUMBER
4.00	0.5 to 2.5	5.00	8.00	1.20	4.10	2.20	DAS-4005-O
4.00	1.5 to 3.0	6.00	8.00	1.20	4.10	2.20	DAS-4006-O
4.00	3.0 to 4.5	7.00	8.00	1.20	4.10	2.20	DAS-4007-O
4.00	3.0 to 5.0	8.00	8.00	1.20	4.10	2.20	DAS-4008-O
4.00	5.0 to 6.5	10.00	8.00	1.20	4.10	2.20	DAS-4010-O
4.00	6.5 to 8.5	12.00	8.00	1.20	4.10	2.20	DAS-4012-O
4.00	8.5 to 10.5	14.00	8.00	1.20	4.10	2.20	DAS-4014-O
4.00	10.5 to	16.00	8.00	1.20	4.10	2.20	DAS-4016-O
4.00	12.5 to 14.5	18.00	8.00	1.20	4.10	2.20	DAS-4018-O
4.00	14.5 to 16.5	20.00	8.00	1.20	4.10	2.20	DAS-4020-O

For additional information and technical support please contact R.T.S. technical sales department . R.T.S. reserve the right to change specifications at any time . Information given is for guidance only and should not be used for specific design criteria without reference to our application engineers.