

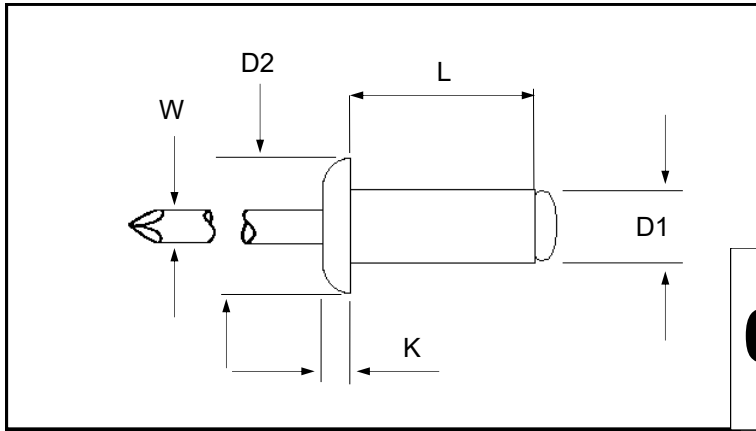

RIVETNUT TECHNOLOGY SYSTEMS LIMITED

DAS- ALUMINIUM BLIND RIVETS 2.4 ø to 6.4 ø

TECHNICAL DATA SHEET



Dome headed Aluminium rivets for material up to 35.00 mm

All dimensions in mm.
Rivet body - Aluminium
Stem - steel zinc plated

R.T.S. SALES LINE
01296 330331

BODY Ø D1	GRIP RANGE	LENGTH L	HEAD Ø D2	HEAD DEPTH K	DRILL SIZE	NAIL Ø W	PART NUMBER
2.40	0.5 to 2.0	4.00	5.00	0.80	2.50	1.45	DAS-2404-O
2.40	2.0 to 4.0	6.00	5.00	0.80	2.50	1.45	DAS-2406-O
2.40	4.0 to 6.0	8.00	5.00	0.80	2.50	1.45	DAS-2408-O
3.00	7.0 to 9.0	12.00	6.00	1.00	3.10	1.80	DAS-3012-O
3.20	1.5 to 3.5	6.00	6.00	1.00	3.30	1.80	DAS-3206-O
3.20	3.5 to 5.5	8.00	6.00	1.00	3.30	1.80	DAS-3208-O
3.20	5.5 to 7.0	10.00	6.00	1.00	3.30	1.80	DAS-3210-O
3.20	7.0 to 9.0	12.00	6.00	1.00	3.30	1.80	DAS-3212-O
3.20	9.0 to 12.0	15.00	6.00	1.00	3.30	1.80	DAS-3215-O
3.20	12.0 to 15.0	18.00	6.00	1.00	3.30	1.80	DAS-3218-O
4.00	1.5 to 3.0	6.00	8.00	1.20	4.10	2.20	DAS-4006-O
4.00	3.0 to 5.0	8.00	8.00	1.20	4.10	2.20	DAS-4008-O
4.00	5.0 to 6.5	10.00	8.00	1.20	4.10	2.20	DAS-4010-O
4.00	6.5 to 8.5	12.00	8.00	1.20	4.10	2.20	DAS-4012-O
4.00	8.5 to 10.5	14.00	8.00	1.20	4.10	2.20	DAS-4014-O
4.00	10.5 to 12.5	16.00	8.00	1.20	4.10	2.20	DAS-4016-O
4.00	12.5 to 14.5	18.00	8.00	1.20	4.10	2.20	DAS-4018-O
4.80	3.0 to 4.5	8.00	9.00	1.50	4.90	2.75	DAS-4808-O
4.80	4.5 to 6.0	10.00	9.00	1.50	4.90	2.75	DAS-4810-O
4.80	6.0 to 8.0	12.00	9.00	1.50	4.90	2.75	DAS-4812-O
4.80	8.0 to 10.0	14.00	9.00	1.50	4.90	2.75	DAS-4814-O
4.80	12.0 to 14.0	16.00	9.00	1.50	4.90	2.75	DAS-4816-O
5.00	12.0 to 14.0	20.00	9.00	1.50	5.10	2.75	DAS-5018-O
6.00	2.0 to 4.0	8.00	11.00	1.60	6.10	2.95	DAS-6008-O
6.40	2.0 to 6.0	12.00	13.00	1.80	6.50	2.95	DAS-6412-O
6.40	9.0 to 12.00	18.00	13.00	1.80	6.50	2.95	DAS-6418-O
6.40	13.0 to 17.0	22.00	13.00	2.00	6.50	2.95	DAS-6422-O
6.40	17.0 to 21.0	26.00	13.00	2.00	6.50	2.95	DAS-6426-O
6.40	25.0 to 30.0	35.00	13.00	2.00	6.50	2.95	DAS-6435-O

Other sizes are available upon request

For additional information and technical support please contact R.T.S. technical sales department . R.T.S. reserve the right to change specifications at any time . Information given is for guidance only and should not be used for specific design criteria without reference to our application engineers.