

CII COUNTERSUNK RIVETS

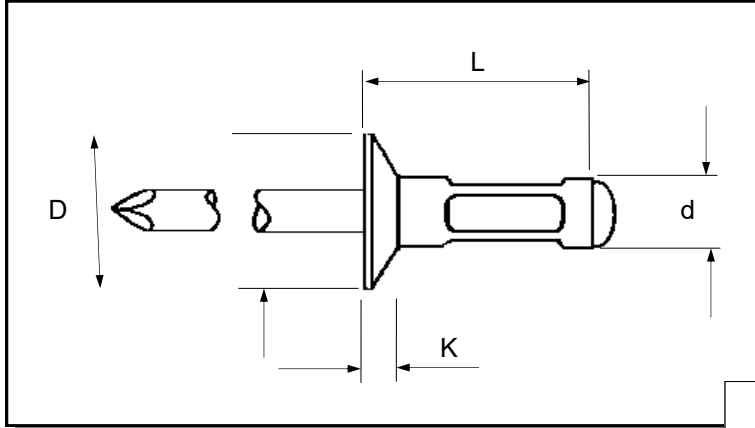

C.K.S. headed Stainless steel rivets for material up to 18.00 mm

All dimensions in mm.
Rivet body - Stainless steel
Stem - Self colour

R.T.S. SALES LINE

01296 330331

BODY Ø d	GRIP RANGE	LENGTH L	HEAD Ø D	HEAD DEPTH K	DRILL SIZE	NAIL Ø W	PART NUMBER
3.20	1.5 to 3.0	6.00	6.30	1.00	3.30	2.10	CII-3206-O
3.20	3.0 to 5.0	8.00	9.30	1.00	3.30	2.10	CII-3208-O
4.00	2.5 to 4.5	8.00	7.50	1.10	4.10	2.50	CII-4008-O
4.00	6.5 to 8.5	12.00	7.50	1.10	4.10	2.50	CII-4012-O
4.80	1.5 to 4.0	8.00	9.00	1.40	4.90	2.90	CII-4808-O
4.80	4.0 to 6.0	10.00	9.00	1.40	4.90	2.90	CII-4810-O
4.80	6.0 to 8.0	12.00	9.00	1.40	4.90	2.90	CII-4812-O
4.80	8.0 to 9.5	14.00	9.00	1.40	4.90	2.90	CII-4814-O
4.80	11.0 to 13.0	18.00	9.00	1.40	4.90	2.90	CII-4818-O

For additional information and technical support please contact R.T.S. technical sales department . R.T.S. reserve the right to change specifications at any time . Information given is for guidance only and should not be used for specific design criteria without reference to our application engineers.