



# User Manual

**iGen450DFc**  
Digital Inverter Generator



**DO NOT RETURN THIS PRODUCT TO THE STORE**  
If you have questions or need assistance, please call customer service at 855-944-3571.

# INTRODUCTION

## TABLE OF CONTENTS

DISCLAIMERS.....	2
ALL RIGHTS RESERVED.....	2
<b>INTRODUCTION</b>	
SPECIFICATIONS.....	3
<b>SAFETY</b>	
SAFETY DEFINITIONS.....	4
SAFETY SYMBOLS.....	4
SAFETY INSTRUCTIONS.....	5
CO SENSOR.....	9
ACTION LABEL.....	9
CONTROL PANEL CO AUTO-SHUTOFF.....	9
<b>COMPONENTS</b>	
GENERATOR COMPONENTS.....	10
CONTROL PANEL COMPONENTS.....	11
<b>ASSEMBLY</b>	
CARTON CONTENTS.....	12
INITIAL OIL FILL.....	12
FUEL.....	13
CONNECT AN LPG/PROPANE TANK.....	13
CONNECT THE BATTERY.....	14
<b>OPERATION</b>	
GENERATOR LOCATION.....	15
GROUNDING.....	15
HIGH ALTITUDE OPERATION.....	15
REMOTE START.....	16
FUEL SELECTOR SWITCH.....	16
BEFORE STARTING THE GENERATOR.....	16
STARTING THE ENGINE: GASOLINE.....	16
STARTING THE ENGINE: PROPANE.....	17
SWITCHING FUEL SOURCES.....	17
STOPPING THE ENGINE.....	17

FREQUENCY OF USE.....	18
AC CIRCUIT BREAKERS.....	18
ECO MODE.....	18
OVERLOAD RESET.....	18
GENERATOR CAPACITY.....	19
POWER MANAGEMENT.....	19
EXTENSION CORDS.....	20
PARALLEL OPERATION.....	20
TRANSPORTING.....	21

## MAINTENANCE

MAINTENANCE SCHEDULE.....	22
MAINTENANCE REPLACEMENT PARTS.....	22
AIR FILTER MAINTENANCE.....	22
ENGINE OIL LEVEL CHECK.....	23
ENGINE OIL CHANGE.....	24
SPARK PLUG MAINTENANCE.....	24
SPARK ARRESTOR SERVICE.....	25
BATTERY MAINTENANCE.....	25
BATTERY REPLACEMENT.....	25
STORAGE.....	26
VALVE CLEARANCE.....	27

## TROUBLESHOOTING

TROUBLESHOOTING.....	29
----------------------	----

## EXPLODED VIEW AND PARTS LIST

ENGINE EXPLODED VIEW.....	30
ENGINE PARTS LIST.....	31
GENERATOR EXPLODED VIEW.....	33
GENERATOR PARTS LIST.....	34

## SCHEMATICS

<b>ESPAÑOL</b> .....	38
<b>FRANÇAIS</b> .....	68

## ALL RIGHTS RESERVED

All rights reserved. No reproduction allowed in any form without written permission from Westinghouse Outdoor Power Equipment, LLC.

**⚠ WARNING:** Operating, servicing, and maintaining this equipment can expose you to chemicals including engine exhaust, carbon monoxide, phthalates, and lead, which are known to the State of California to cause cancer and birth defects or other reproductive harm. To minimize exposure, avoid breathing exhaust, and wear gloves or wash your hands frequently when servicing this equipment. For more information go to [www.P65warnings.ca.gov](http://www.P65warnings.ca.gov).

## DISCLAIMERS

All information, illustrations, and specifications in this manual were in effect at the time of publishing. The illustrations used in this manual are intended as representative reference views only. We reserve the right to make any specification or design change without notice.

<b>⚠ DANGER</b>	
	Read this manual before using or performing maintenance on this product. Failure to follow the instructions and safety precautions in this manual can result in serious injury or death.

## SAVE THESE INSTRUCTIONS

## INTRODUCTION

### SPECIFICATIONS

Specifications	
<b>Model:</b>	iGen4500DFc
<b>Running Watts:</b>	3700 Gas / 3330 LPG
<b>Peak Watts:</b>	4500 Gas / 4050 LPG
<b>Rated Voltage:</b>	120V
<b>Rated frequency:</b>	60 Hz
<b>Phase:</b>	Single phase
<b>Total Harmonic Distortion:</b>	≤ 3%
<b>Engine Displacement:</b>	224 cc
<b>Starting Type:</b>	Recoil, Electric Start, Remote
<b>Fuel Capacity:</b>	3.4 Gal (12.8 L)
<b>Fuel Type:</b>	87–93 octane*
<b>Oil Capacity:</b>	0.63 US qt (0.60 L)
<b>Oil Type:</b>	10W30
<b>Spark Plug:</b>	F7RTC
<b>Spark Plug Gap:</b>	0.024 – 0.032 in. (0.60 – 0.80 mm)
<b>Valve Intake Clearance:</b>	0.0031 – 0.0047 in. (0.08 – 0.12 mm)
<b>Valve Exhaust Clearance:</b>	0.0051 – 0.0067 in. (0.13 – 0.17 mm)
<b>AC Grounding System:</b>	Floating neutral
<b>Voltage Regulator:</b>	Digital
<b>Alternator Type:</b>	Permanent magnet
<b>Maximum Ambient Temperature:</b>	104°F (40°C)
<b>Certifications:</b>	<ul style="list-style-type: none"> <li>• EPA</li> <li>• CARB</li> </ul>

\*Ethanol content of 10% or less. DO NOT use E15 or E85.

### NOTICE

This product is designed and rated for continuous operation at ambient temperatures up to 104°F (40°C). If needed, this product can be operated at temperatures ranging from 5°F (15°C)–122°F (50°C) for short periods. If the product is exposed to temperatures outside of this range during storage, it should be brought back within this range before operation. This product must always be operated outdoors in a well-ventilated area and away from doors, windows, and other vents.

Maximum wattage and current are subject to and limited by such factors as fuel BTU content, ambient temperature, altitude, engine conditions, etc. Maximum power decreases about 3.5% for each 1,000 feet above sea level, and will also decrease about 1% for each 10°F (6°C) above 60°F (16°C) ambient temperature.

### PRODUCT REGISTRATION

For trouble-free warranty coverage, it is important to register your Westinghouse generator.

You can register by:

- Completing and mailing the product registration card included in the carton.
- Registering your product online at: <https://westinghouseoutdoorpower.com/pages/warranty-registration>
- Scanning the following QR code with your smartphone camera. You will be directed to the mobile registration link.



- Sending the following product information to:

Westinghouse Outdoor Power  
Warranty registration  
777 Manor Park Drive  
Columbus, OH 43228

#### For Your Records

Date of Purchase: \_\_\_\_\_

Model Number: \_\_\_\_\_

Serial Number: \_\_\_\_\_

Place of Purchase: \_\_\_\_\_

**IMPORTANT:** Keep your purchase receipt for trouble-free warranty coverage.

# SAFETY

## SAFETY

### SAFETY DEFINITIONS

The words DANGER, WARNING, CAUTION and NOTICE are used throughout this manual to highlight important information. Make sure that the meanings of this safety information is known to all who operate, perform maintenance on, or are near the generator.



**This safety alert symbol appears with most safety statements. It means attention, become alert, your safety is involved! Please read and abide by the message that follows the safety alerts symbol.**

#### ▲ DANGER

Indicates a hazardous situation which, if not avoided, will result in death or serious injury.

#### ▲ WARNING

Indicates a hazardous situation which, if not avoided, could result in death or serious injury.

#### ▲ CAUTION

Indicates a hazardous situation which, if not avoided, could result in minor or moderate injury.

#### NOTICE

Indicates a situation which can cause damage to the generator, personal property, and/or the environment, or cause the equipment to operate improperly.

**Note:** Indicates a procedure, practice or condition that should be followed for the generator to function in the manner intended.

### SAFETY SYMBOLS

Follow all safety information contained in this manual and on the generator.

Symbol	Description
	Safety Alert Symbol
	Electrocution Hazard
	Asphyxiation Hazard
	Burn Hazard. Do not touch hot surfaces.
	Electrical Shock Hazard
	Fire Hazard
	Maintain Safe Distance
	Lifting Hazard
	Read Manufacturer's Instructions
	Do Not Operate in Wet Conditions

## SAFETY INSTRUCTIONS

### CORRECT USE

Example location to reduce risk of carbon monoxide poisoning

- ONLY use outside and downwind, far away from windows, doors and vents.
- Direct exhaust away from occupied spaces

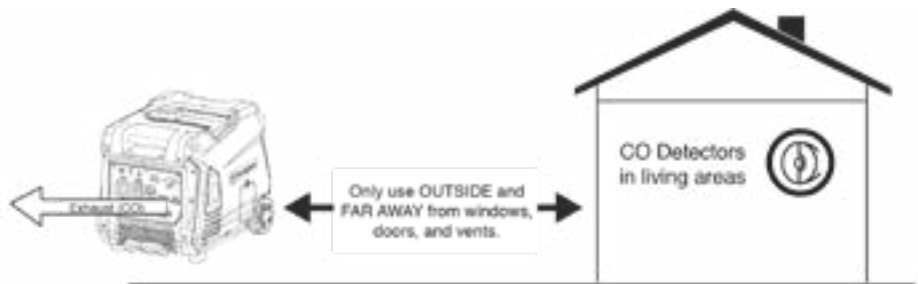

### INCORRECT USE

Do not operate in any of the following locations:

- Near any door, window, or vent
- Garage
- Basement
- Crawl Space
- Living Area
- Attic
- Entry Way
- Porch
- Mudroom

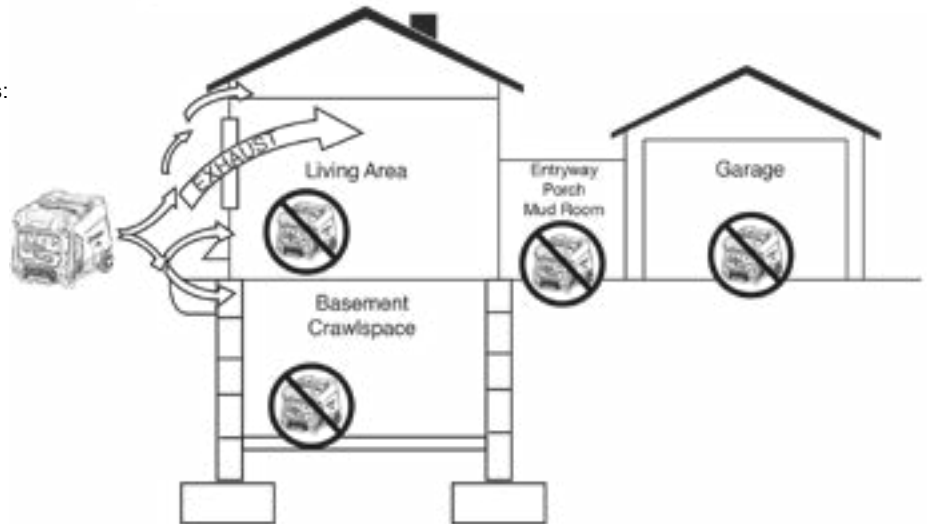

### NOTICE

Install battery-powered carbon monoxide detectors or plug-in carbon monoxide detectors with battery back-up in living areas.

### ⚠ DANGER

Fire and electrocution hazard. **DO NOT** connect to a building's electrical system unless the generator and transfer switch have been properly installed and the electrical output has been verified by a qualified electrician. The connection must isolate the generator power from utility power and must comply with all applicable laws and electrical codes.

### ⚠ DANGER

Using a generator indoors **CAN KILL YOU IN MINUTES**. Generator exhaust contains carbon monoxide. This is a poison you cannot see or smell.



**NEVER** use inside a home or garage, **EVEN IF** doors and windows are open.



Only use **OUTSIDE** and far away from windows, doors, and vents.

### ⚠ DANGER

Electrocution hazard. Never use the generator in a location that is wet or damp. Never expose the generator to rain, snow, water spray, or standing water while in use. Protect the generator from all hazardous weather conditions. Moisture or ice can cause a short circuit or other malfunction in the electrical circuit.

# SAFETY

## GENERAL SAFETY PRECAUTIONS

- **NEVER** use the generator to power medical support equipment.
- **DO NOT** operate the generator when you are tired or under the influence of drugs, alcohol, or medication.
- **DO NOT** use generator with electrical cords which are worn, frayed, bare, or otherwise damaged.
- All electrical tools and appliances operated from this generator must be properly grounded by use of a third wire or be double-insulated.
- When this generator is used to supply a building wiring system the generator must be installed by a qualified electrician and connected to a transfer switch as a separately derived system in accordance with NFPA 70, National Electrical Code.
- If you begin to feel sick, dizzy, or weak while using the generator, move to fresh air **IMMEDIATELY**. See a doctor, as you can have carbon monoxide poisoning.
- Only use **OUTSIDE** and far away from windows, doors, and vents as recommended by the US Department of Health and Human Services Centers for Disease Control and Prevention. Your specific home and/or wind conditions may require additional distance.
- While operating and storing, keep at least five feet
- of clearance on all sides of the generator, including overhead. Allow the generator to cool a minimum of 30 minutes before storage. Heat created by the muffler and exhaust gases could be hot enough to cause serious burns and/or ignite combustible objects.
- **DO NOT** touch the muffler or engine. They are very **HOT** and will cause severe burns. **DO NOT** put body parts or any flammable or combustible materials in the direct path of the exhaust.
- **ALWAYS** remove any tools or other service equipment used during maintenance away from the generator before operating.
- Avoid skin contact with engine oil or gasoline. Wear protective clothing and equipment. Wash all exposed skin with soap and water.
- A transfer switch must be installed by a licensed electrician approved by the authority having jurisdiction. The installation must comply with all applicable laws and electrical codes.

## FUEL SAFETY

- Store fuel in a container approved for gasoline.
- **DO NOT** smoke when filling the generator with gasoline.
- **DO NOT** allow the generator's gas tank to overflow when filling.
- Shut down the engine and allow it to cool for two minutes before adding gasoline or oil to the generator.
- **NEVER** remove the fuel cap when the generator is running. Shut off the engine and allow the unit to cool at least two minutes. Remove the fuel cap slowly to release pressure, keep fuel from escaping around the cap, and to avoid the heat from the muffler igniting fuel vapors. Tighten the fuel cap securely after refueling.
- Wipe spilled fuel from the unit.
- **NEVER** attempt to burn off spilled fuel.
- **NEVER** overfill the fuel tank. Leave room for fuel to expand. Overfilling the fuel tank can result in a sudden overflow of gasoline and result in spilled gasoline coming in contact with **HOT** surfaces.
- Spilled fuel can ignite. If fuel is spilled on the generator, wipe up any spills immediately. Dispose of rag properly. Allow area of spilled fuel to dry before operating the generator.
- Wear eye protection while refueling.
- **NEVER** use gasoline as a cleaning agent.
- Store any containers containing gasoline or LPG/propane in a well-ventilated area, away from any combustibles or source of ignition.

## GASOLINE AND GASOLINE VAPOR (GAS)

### ▲ DANGER

Fire and explosion hazard. Gasoline and LPG/propane are highly explosive and flammable and can cause severe burns or death.

- In case of a gas fire, **DO NOT** attempt to extinguish the flame if the fuel tank valve is in the **ON** position. Introducing an extinguisher to a generator with an open fuel valve could create an explosion hazard.
- Gas has a distinctive odor, this will help detect potential leaks quickly.
- Gas vapors can cause a fire if ignited.
- Gasoline is a skin irritant and needs to be cleaned up immediately if it comes in contact with the skin.



## LIQUID PETROLEUM GAS (LPG/PROPANE)

### ▲ WARNING

Fire and explosion hazard. **NEVER** use a gas container, LPG/propane connector hose, LPG/propane tank or any other fuel item that appears to be damaged.

### ▲ CAUTION

Fire and explosion hazard. Only use approved LPG/propane tanks with an Overfilling Prevention Device (OPD) valve. **ALWAYS** keep the tank in a vertical position with the valve on top and placed at ground level on a flat surface. **DO NOT** allow tanks to be near any heat source. When transporting and storing, turn the propane tank valve to the fully closed position and disconnect the tank. Make sure to **ALWAYS** cover the generator inlet and tank outlet with protective plastic caps.

- LPG/Propane is highly flammable and explosive.
- Flammable gas under pressure can cause a fire or explosion if ignited.
- LPG/Propane can settle in low places because it is heavier than air.
- LPG/Propane has a distinctive odor added to help detect potential leaks.
- **ALWAYS** keep a LPG/Propane tank in an upright position.
- When exchanging LPG/propane tanks, be sure the tank valve is the same type.
- In case of a LPG/propane fire, **DO NOT** attempt to extinguish unless the fuel supply can be shut off safely.
- LPG/propane will burn the skin. Prevent skin contact at all times.
- Keep the propane tank away from the generator exhaust.
- Large (500–1000 gallon) LPG/propane tanks will require a certified plumber to install the fuel line to the generator and the loose regulator is not used (the regulator that is attached to the fuel tank). The pressure as measured at the regulator mounted to the generator must be 7" to 14" of water column. A certified plumber must ensure that the pressure is correct or install a step down regulator if needed.

### ▲ WARNING

Fire and explosion hazard. If there is a strong smell of propane while operating the generator, fully close the LPG/propane tank valve immediately. Once the propane is off, use soapy water to check for leaks on the hose and connections on the tank valve and the generator. **DO NOT** smoke or light a cigarette or check for leaks using any open flame source such as a match or lighter. If a leak is found, contact a qualified technician to inspect and repair the LPG/propane system before using the generator.

#### When starting the generator:

- Make sure that the fuel cap, air filter, spark plug, fuel lines, and exhaust system are properly in place.
- If you spill any gasoline on the tank, allow it to fully evaporate before operating.
- Make sure the generator and LPG/propane tank are on a flat surface before operating.
- If there is a propane odor **DO NOT** start the unit because there may be a potential leak. **NEVER** place a LPG/propane tank near the engine exhaust.

#### When transporting or servicing the generator:

- Make sure the LPG/propane tank and LPG/propane hose are not attached to the generator.
- Disconnect the spark boot to prevent accidental starting.

#### When storing the generator:

- Store away from sparks, open flames, pilot lights, heat, and other sources of ignition.
- **DO NOT** store gas or a LPG/propane tank near furnaces, water heaters, or any other appliances that produce heat or have automatic ignitions.

# SAFETY

## SAFETY LABELS AND DECALS

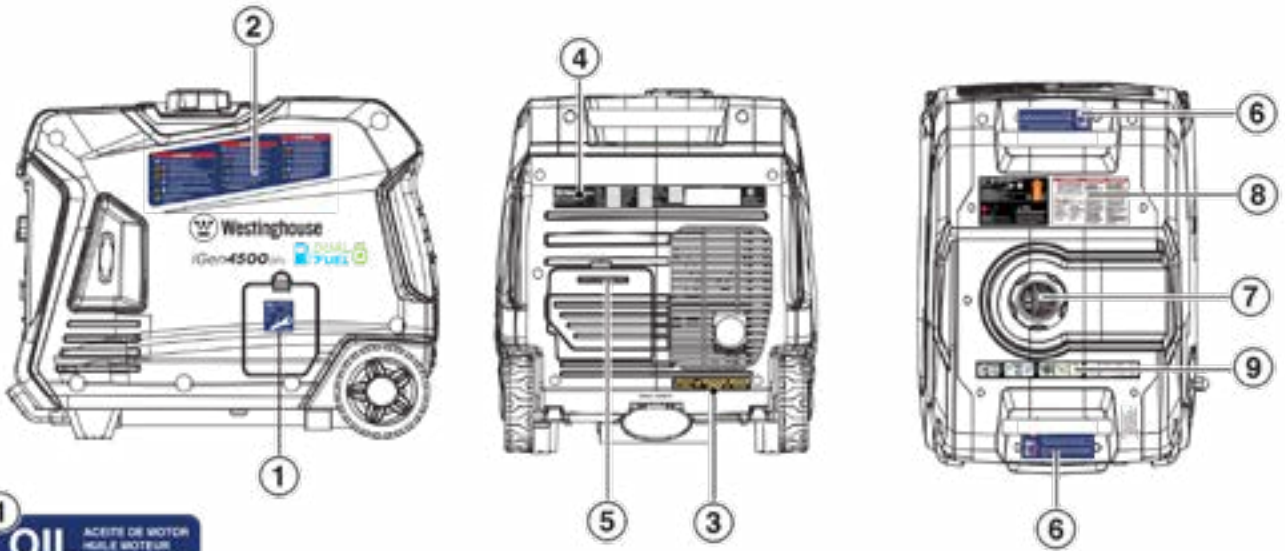

**1 OIL** ACEITE DE MOTOR / OIL  
 Oil Capacity: 5.5 QT / 52.5 L / 55.5 GAL / 500 ML  
 SAE 10W-30  
 Safe Operating Range

**5 BATTERY | BATERÍA | BATTERIE**

**3 CAUTION HOT SURFACES** / **PRECAUCIÓN SUPERFICIES CALIENTES** / **ATTENTION SURFACES CHAUDES**

**6 WARNING ! PELIGRO ! ATTENTION**  
 Operate, store, and transport on firm level surface. Do not rest on exhaust panel. Tipping can cause fuel spillage.  
 Opere, almacene y transporte sobre una superficie firme e nivelada. No descansa sobre el panel de escape. La inclinación puede provocar un derrame de combustible.  
 Utilisez, stockez et transportez sur une surface plane et ferme. Ne vous appuyez pas sur le panneau d'échappement. L'inclinaison peut provoquer un déversement de carburant.

**4** Westinghouse  
 Serial Number

**2 DANGER**  
 Failure to follow warnings, instructions and operator's manual will result in death or serious injury.  
 Generator could cause electrical shock.  
 • 70% of gas fire fatalities.  
 • 22% of deaths in fire in well-ventilated areas.  
 • Generator should never be used when connected to a building.  
 Never fuel and start engine running. Always fuel and start engine with generator off and in well-ventilated area. Always allow unit to cool before refueling.  
 143 muffler and exhaust gases can cause fire. Keep at least 3.4 m (11 ft) clearance from any combustibles or structures, including overhanging.  
 Exhaust contains poisonous carbon monoxide gas that can cause unconsciousness or DEATH. Never Carbon Monoxide enters inside home.  
 For electrical equipment only. Failure to properly ground generator can result in electrocution.

**PELIGRO**  
 No obedezca las advertencias e instrucciones y el manual del operador generará lesiones graves o la muerte.  
 El generador puede causar una descarga eléctrica.  
 • 70% de las muertes por incendios.  
 • 22% de las muertes en incendios en áreas bien ventiladas.  
 • El generador nunca debe usarse cuando está conectado a un edificio.  
 Nunca opere el motor con el tanque de combustible. Siempre opere el generador con el motor apagado y en un área bien ventilada. Siempre espere que el motor se enfríe antes de repostar.  
 Los gases del escape y los gases del escape pueden causar un incendio. Mantenga al menos 3.4 m (11 ft) de distancia de cualquier combustible o estructura, incluso sobresaliente.  
 Los gases de escape contienen un gas venenoso llamado monóxido de carbono que puede causar pérdida de conciencia o MUERTE. Nunca permita que el monóxido de carbono entre en su hogar.  
 Solo para equipos eléctricos. Si no se conecta correctamente el generador puede resultar en electrocución.

**DANGER**  
 No obedecer las advertencias e instrucciones de este manual generará lesiones graves o la muerte.  
 El generador puede causar una descarga eléctrica.  
 • 70% de las muertes por incendios.  
 • 22% de las muertes en incendios en áreas bien ventiladas.  
 • El generador nunca debe usarse cuando está conectado a un edificio.  
 Nunca opere el motor con el tanque de combustible. Siempre opere el generador con el motor apagado y en un área bien ventilada. Siempre espere que el motor se enfríe antes de repostar.  
 Los gases del escape y los gases del escape pueden causar un incendio. Mantenga al menos 3.4 m (11 ft) de distancia de cualquier combustible o estructura, incluso sobresaliente.  
 Los gases de escape contienen un gas venenoso llamado monóxido de carbono que puede causar pérdida de conciencia o MUERTE. Nunca permita que el monóxido de carbono entre en su hogar.  
 Solo para equipos eléctricos. Si no se conecta correctamente el generador puede resultar en electrocución.

**7 DO NOT OVERFILL**  
**3.4 Gal**  
**12.6 L**  
**USE FUEL STABILIZER FOR STORAGE**  
 UTILISEZ UN STABILISATEUR DE COMBUSTIBLE POUR LE STOCKAGE  
 EL USO DEL ESTABILIZADOR DE COMBUSTIBLE PARA EL ALMACENAMIENTO  
 • AT MINIMUM OCTANE 87  
 • AT OCTANO MINIMUM 87  
 • AT OCTANO MINIMUM 87

**8 ACTION LABEL**  
 AUTOMATIC SYSTEM - 100 MINUTE DELAYED START  
 POINT EXHAUST AWAY

**DANGER** Using a generator indoors CAN KILL YOU IN MINUTES. Generator exhaust contains carbon monoxide. This is a poison you cannot see or smell.  
**PELIGRO** Si usa un generador en interiores, POCOS MINUTOS. El escape del generador contiene monóxido de carbono. Es un veneno que no tiene olor ni se puede ver.  
**DANGER** Utiliser un générateur à l'intérieur PEUT VOUS TUE EN QUELQUES MINUTES. Les gaz d'échappement du générateur contiennent du monoxyde de carbone. C'est un gaz toxique invisible et inodore.  
**NEVER** use inside a home or garage. EVEN if doors and windows are open.  
**Only use OUTSIDE** and far away from windows, doors, and vents.  
**NUNCA** lo use dentro de una casa interior o un garage, AUN si las puertas y ventanas están abiertas.  
**Solo usado EN EXTERIORES** y bien lejos de ventanas, puertas y ductos de ventilación.  
**NE JAMAIS** utiliser à l'intérieur d'une maison ou d'un garage, MÊME si les portes et les fenêtres sont ouvertes.  
**Utiliser UNIQUEMENT à l'EXTÉRIEUR** et bien des fenêtres, portes et ventilations.

**9 EZ Start Instructions**  
 GASOLINE SET UP / PROGRAME SET UP / START / MANUAL START / ELECTRIC START / BATTERY START



## CO SENSOR

The CO Sensor monitors for the accumulation of poisonous carbon monoxide gas around the generator when the engine is running. If increasing levels of CO gas are detected, the CO Sensor automatically shuts down the engine.

The CO Sensor will also detect the accumulation of carbon monoxide from other fuel burning sources used in the area of operation. For example, if the exhaust of fuel burning tools is pointed at a CO Sensor-equipped generator, a shut-off may be initiated due to rising CO levels. This is not an error. Hazardous carbon monoxide has been detected. Move and redirect any additional fuel burning sources to dissipate carbon monoxide away from personnel and occupied buildings.

**Note:** Remote start-equipped generators must be restarted with the START/STOP button on the control panel after an automatic shut-down occurs.

Generators are intended to be used outdoors, far from occupied buildings and the exhaust pointed away from personnel and buildings. If misused and operated in a location that results in the accumulation of CO, like in a partially enclosed area, the CO Sensor shuts off the engine, notifies the user with a RED indicator light, and directs the user to read the Action Label for steps to take. The CO Sensor **DOES NOT** replace carbon monoxide alarms. Install battery-powered carbon monoxide alarm(s) in your home.

**▲ WARNING**

Automatic shutoff accompanied with a flashing RED light in the CO Sensor portion of the control panel is an indication that the generator was improperly located. If you start to feel sick, dizzy, weak, or carbon monoxide detectors in your home indicate an alarm, get to fresh air immediately. Call emergency services. You may have carbon monoxide poisoning.

## ACTION LABEL

**ACTION LABEL**

ETIQUETA DE FUNCIONAMIENTO  
ÉTIQUETTE D'ACTION

- MOVE GENERATOR TO AN OPEN, OUTDOOR AREA.
- POINT EXHAUST AWAY.
- DON'T RUN GENERATOR IN ENCLOSED AREAS (i.e. NOT IN HOUSE OR GARAGE).
- MOUVEN EL GENERADOR A UN ÁREA ABIERTA, EN EXTERIORES.
- ORIENTAR EL TUBO DE ESCAPE HACIA AFUERA.
- NO ACTIVAR EL GENERADOR EN ÁREAS CERRADAS (i.e. EN UNA CASA O GARAJE).
- DÉPLACER LA GÉNÉRATRICE DANS UN ESPACE EXTÉRIEUR OUVERT.
- DIRIGIR L'ÉCHAPPEMENT LOIN DE VOUS.
- NE PAS FAIRE FONCTIONNER LA GÉNÉRATRICE DANS DES ENDROITS FERMÉS.

**WARNING**  
ADVERTENCIA  
AVERTISSEMENT

TAMPERING WITH CARBON MONOXIDE SENSOR COULD RESULT IN HAZARDOUS CONDITION  
RACER ALTERACIONES CON SENSOR DE MONÍTOREO DE CARBONO PODRÍA OCASIONAR CONDICIONES PELIGROSAS  
L'ÉCARTATION DE CAPTEUR DE MONITEUR DE CARBONE PEUT ENTRAÎNER DES CONDITIONS DANGEREUSES

**AUTOMATIC SHUTOFF - YOU MUST:**  
ETIQUETA DE FUNCIONAMIENTO:  
ÉTIQUETTE D'ACTION:



- MOVE TO FRESH AIR.
- GET MEDICAL HELP IF SICK, DIZZY OR WEAK.
- MOVER AL AIRE LIBRE.
- OBTENER ATENCIÓN MÉDICA SI SE SIENTE ENFERMO, MAREADO O DÉBIL.
- IRRSER RETIRAR A L'AIR FRAIS.
- CONSULTER UN MÉDECIN SI VOUS ÊTES MALADE, ÉTUNDI OU FAIBLE.



**POINT**  
ORIENTAR  
DIRIGIR

**EXHAUST**  
EL TUBO DE ESCAPE  
L'ÉCHAPPEMENT

**AWAY**  
HACIA AFUERA  
LOIN DE VOUS

## CONTROL PANEL CO AUTO-SHUTOFF



## CO SENSOR INDICATOR LIGHTS

Color	Description
<b>RED</b>	<p>Carbon monoxide accumulated around the generator. After shut-off, the RED indicator light in the CO Sensor area of the control panel will flash to provide notification that the generator was shut-off due to an accumulating CO hazard. The RED light will flash for at least five minutes after a CO shut-off.</p> <p>Move the generator to an open, outdoor area far away from occupied spaces with exhaust pointed away. Once relocated to a safe area, the generator can be restarted. Introduce fresh air and ventilate the area where the generator had shut down.</p>
<b>YELLOW</b>	<p>A CO sensor system fault occurred. When a system fault occurs, the generator is automatically shut down and the YELLOW indicator light in the CO auto-shutoff area of the control panel will flash to provide notification that a fault has occurred. The YELLOW light will flash for at least five minutes after a fault. The generator can be re-started, but may continue to shutoff. A CO sensor fault can only be diagnosed and repaired by an authorized Westinghouse service center.</p>

# COMPONENTS

## COMPONENTS

### GENERATOR COMPONENTS

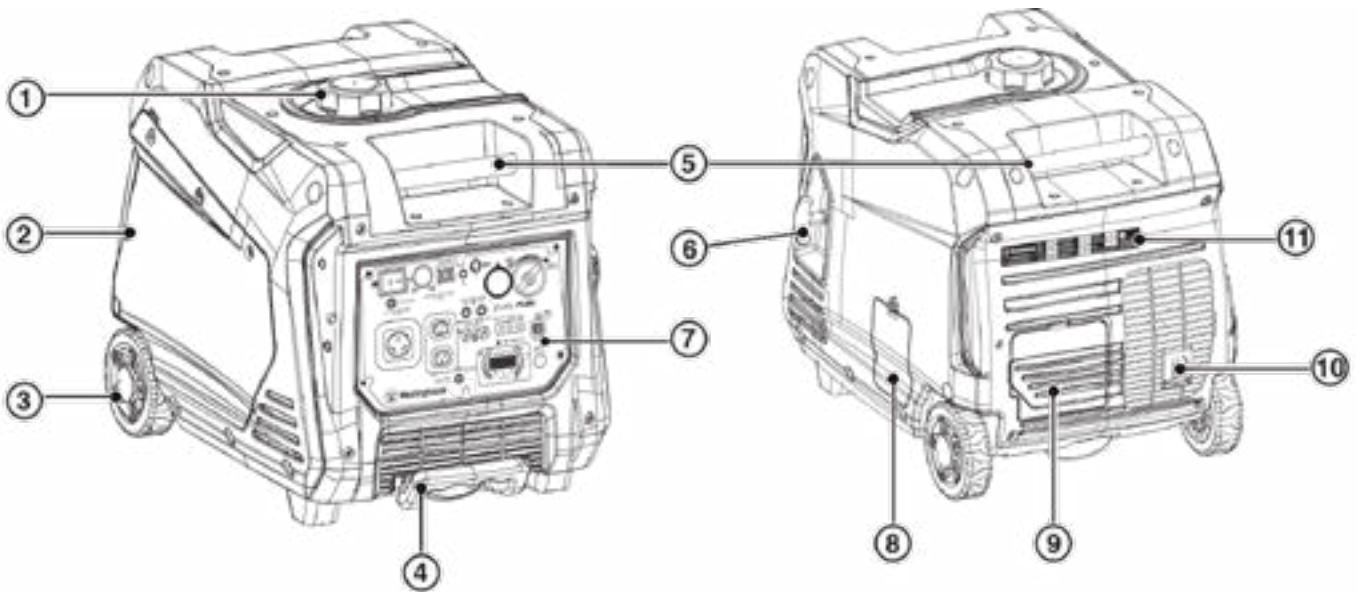

- 1. Fuel Cap:** Add unleaded fuel here. Close the cap until it clicks.
- 2. Engine Service Cover:** Cover provides access to the engine, air cleaner, carburetor, and spark plug.
- 3. Transport Wheels:** Wheels allow one-handed maneuverability when used with the extendable handle.
- 4. Extendable Handle:** Extend and retract the handle by pushing the locking button.
- 5. Carry Handles:** Built-in handles allow easy, two-person transport.
- 6. Recoil Handle:** Pull the recoil handle to manually start the engine.
- 7. Control Panel:** The control panel contains the outlets and operational controls.
- 8. Oil Access Cover:** Cover provides access to the oil fill cap/dipstick and oil drain plug.
- 9. Battery Access Cover:** Cover provides access to the battery and quick-connect plug.
- 10. Muffler and Spark Arrestor:** The spark arrestor prevents sparks from exiting the muffler.
- 11. Model Information Label:** Provides model serial number, voltage/amps, and power rating information.

#### DATA CENTER

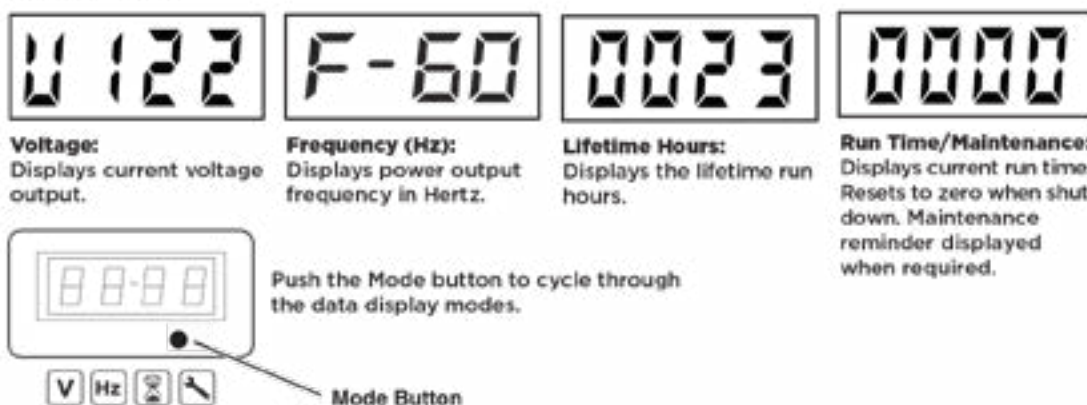

## CONTROL PANEL COMPONENTS

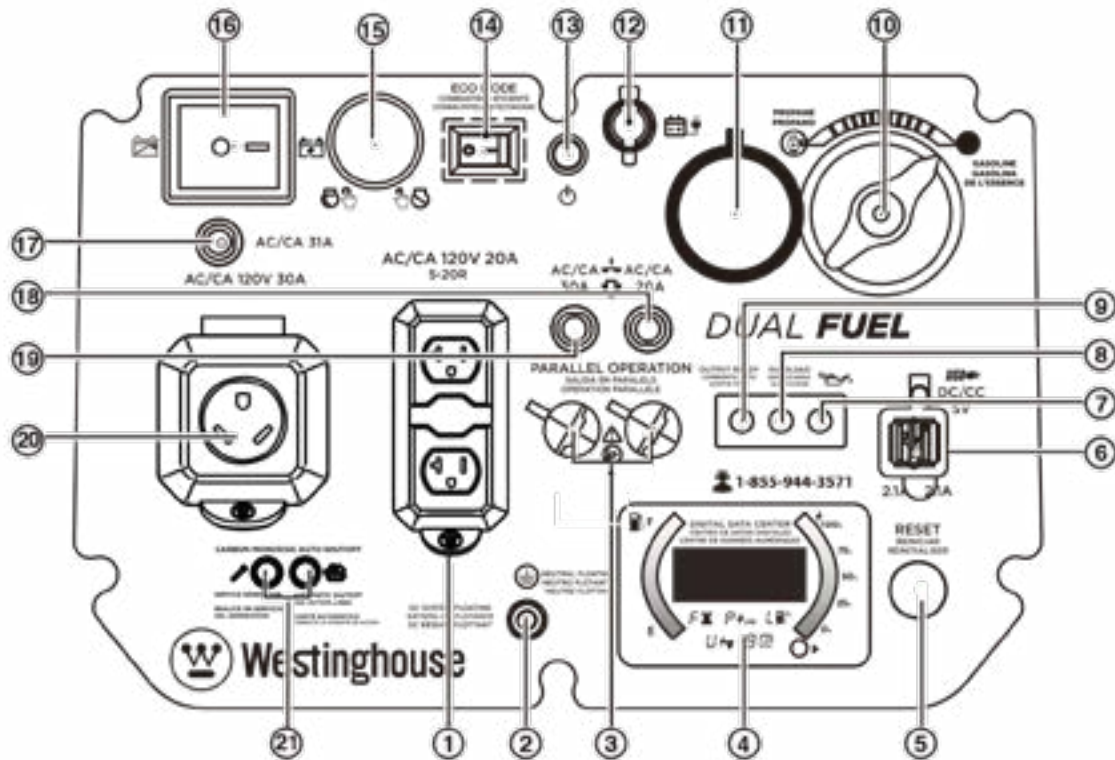

1. **120 Volt AC, 20 Amp Duplex NEMA 5-20R Receptacle:** Receptacle can supply a maximum of 20 Amps.
2. **Ground Terminal:** The ground terminal is used to externally ground the generator.
3. **Parallel Operation Outlets:** A compatible Westinghouse Inverter Generator can be connected for additional power output.
4. **LED Data Center:** Displays remaining run time (F), power output in kW (P), fuel level in liters (L), voltage output (V), and lifetime hours.
5. **Overload Reset:** The generator inverter will automatically switch OFF all AC output to protect the generator if overloaded or if there is a short circuit in a connected appliance.
6. **USB Ports:** Two-port 5V/2.1A USB outlet. Accepts Type A USB plugs.
7. **Low Oil LED:** Indicates low oil level. When the oil level in the crankcase falls below the safe operating limit, the low oil level indicator will illuminate and the generator will automatically shut off the engine.
8. **Overload LED:** Indicates that the generator is overloaded.
9. **Output Ready LED:** Illuminates when the generator is operating normally. Indicates the generator is producing electrical power at the receptacles.
10. **Fuel Selector Switch:** Used to select gas or propane operation.
11. **LPG/Propane Inlet:** Connects a propane tank with the included LPG/propane hose.
12. **Battery Charging Port:** Used to charge the battery with the included battery charger.
13. **Battery Indicator:** Indicates that battery power is ON. Light will remain illuminated while the unit is ON.
14. **Eco Mode:** Eco mode minimizes fuel consumption and noise by adjusting the engine RPM to the minimum required for the current load.
15. **Push-Button Start/Stop:** Push once to automatically start the engine. Push again to stop the engine.
16. **Battery Switch:** Turns battery ON and OFF. Must be ON before electric start or remote start.
17. **Main Circuit Breaker:** The main circuit breaker controls total output of all outlets to protect the generator from overload or short circuit.
18. **20 Amp AC Circuit Breaker:** Circuit breaker limits the current that can be delivered through the NEMA 5-20R receptacle to 20 Amps.
19. **30 Amp AC Circuit Breaker:** Circuit breaker limits the current that can be delivered through the NEMA TT-30 receptacle to 30 Amps.
20. **120 Volt AC, 30 Amp NEMA TT-30R Receptacle:** Receptacle can supply a maximum of 30 Amps.
21. **CO Sensor indicator lights:** The CO Sensor monitors for the accumulation of poisonous carbon monoxide gas. If increasing levels of CO gas are detected, the CO Sensor automatically shuts down the engine.

# ASSEMBLY

## ASSEMBLY

### CARTON CONTENTS

#### ▲ CAUTION

Weight hazard. Always have assistance when lifting the generator.

1. Carefully open the carton.
2. Remove and save the instruction manual, oil bottle, oil funnel, LPG/propane hose, spark plug socket wrench, and battery charger.
3. Remove and discard the packing tray.
4. Unfold the top of the plastic bag enclosing the generator.
5. Carefully cut the vertical corners of the carton to access the generator.
6. Recycle or dispose of the packaging materials properly.

### CARTON CONTENTS

- User manual
- Quick Start Guide/Maintenance Schedule
- LPG/propane hose with regulator
- Remote start key fob (attached to recoil starter)
- 0.63 Quart (0.6 Liter) bottle of SAE 10W-30 Oil
- Battery charger
- Spark plug socket wrench
- Oil Funnel
- Screwdriver

If any parts are missing, contact our service team at [service@wpowereq.com](mailto:service@wpowereq.com) or call 1-855-944-3571.

## INITIAL OIL FILL

### NOTICE

**THIS GENERATOR HAS BEEN SHIPPED WITHOUT OIL.** Do not attempt to crank or start engine before it has been properly serviced with recommended oil. Failure to add engine oil before starting will result in serious engine damage.

### NOTICE

Use of 2-stroke/cycle oil or other unapproved oil types can cause severe engine damage that is not covered under warranty.

The included, recommended oil type for typical use is 10W-30 engine oil. If running the generator in extreme temperatures, refer to the following chart.

Recommended Engine Oil Type									
		10W-30							
	5W-30						10W-40		
	5W-30 Synthetic								
°F	-20	0	20	40	60	80	100	120	
°C	-28.9	-17.8	-6.7	4.4	15.6	26.7	37.8	48.9	
Ambient temperature									

1. On a level surface, remove the oil access cover and oil dipstick.

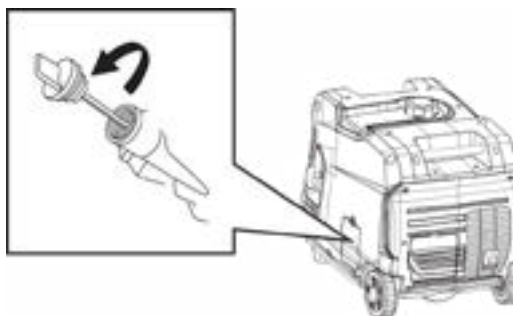

2. Using the supplied funnel and oil, add oil into the engine.

**Note:** As residual oil from the factory may remain in the engine, add the oil incrementally near the end of the bottle to prevent overfilling the engine. See Engine Oil Level Check in the Maintenance section.

3. Wipe the oil dipstick clean. Replace the oil dipstick and hand-tighten.
4. Replace the oil access cover.



## FUEL

### ▲ WARNING

Fire and explosion hazard. Never use a gasoline container, gasoline tank, propane connector hose, propane tanks, or any other fuel item that is broken, cut, torn or damaged.

### ▲ DANGER

Fire and explosion hazard. Do not overfill fuel tank. Fill only to the red fill ring located in the in-tank fuel screen filter. Overfilling may cause fuel to spill onto engine causing a fire or explosion hazard.

### ▲ DANGER

Fire and explosion hazard. **NEVER** refuel the generator while the engine is running. **ALWAYS** turn the engine off and allow the generator to cool for two minutes before refueling.

### NOTICE



**DO NOT** use E15 or E85 fuel in this product. Engine or equipment damage caused by stale fuel or the use of unapproved fuels (such as E15 or E85 ethanol blends) is not covered by warranty. Only use unleaded gasoline containing up to 10% ethanol.

## FUEL REQUIREMENTS

- CLEAN, FRESH, unleaded gasoline, 87–93 octane.
- Up to 10% ethanol (gasohol) is acceptable (where available; non-ethanol fuel is recommended).
- **Do not** use E85 or E15.
- **Do not** use a gas oil mix.
- **Do not** modify the engine to run on alternate fuels.
- **Do not** fuel indoors.

**DO NOT** create a spark or flame while fueling.

## USING FUEL STABILIZER

Adding a fuel stabilizer (not included) extends the usable life of fuel and helps prevent deposits from forming that can clog the fuel system. Follow the manufacturer's instructions for use.

**ALWAYS** mix the correct amount of fuel stabilizer to gasoline in an approved gasoline container before fueling the generator. Run the generator for five minutes to allow the stabilizer to treat the entire fuel system.

## FILLING THE FUEL TANK

1. Turn the generator OFF and allow to cool for a minimum of two minutes before fueling.
2. Place the generator on level ground in a well ventilated area.
3. Clean area around fuel cap and remove the cap slowly.

### NOTICE

Only fill the tank from an approved gasoline container. Make sure the gasoline container is internally clean and in good condition to prevent fuel system contamination.

Slowly add the recommended fuel. **DO NOT** overfill. Fill only to the red maximum fill ring on the fuel screen filter visible in the filler neck.

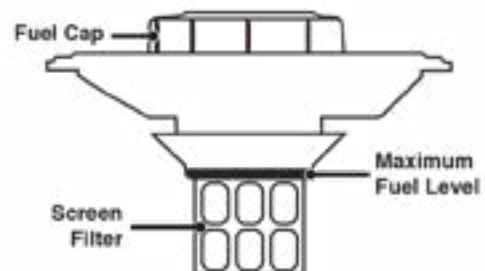

4. Install the fuel cap.

### NOTICE

Fuel can damage paint and plastic. Use caution when filling the fuel tank. Damage caused by spilled fuel is not covered under warranty.

### NOTICE

Clean the fuel screen filter of debris before and after each fueling. Remove the fuel screen filter by slightly compressing it while removing it from the fuel tank.

## CONNECT AN LPG/PROPANE TANK

### NOTICE

- The LPG/propane tank can be of any capacity but the tank must conform to the standard as listed in Fuel Safety section.
- Propane tanks that use liquid withdrawal system can not be used on these models.
- Verify the re-qualification date on the tank has not expired.
- **DO NOT** use included LPG/propane hose for any other appliances.



# ASSEMBLY

## NOTICE

- All new tanks must be purged of air and moisture prior to filling. Used tanks that have not been plugged or kept closed must also be purged. The purging process should be done by a propane supplier (Tanks from an exchange supplier should have been purged and filled properly).
- **ALWAYS** position the tank so the connection between the valve and the gas inlet will not cause sharp bends or kinks in the hose.

## ▲ WARNING

Explosion hazard. **DO NOT** start generator if you smell propane. **ALWAYS** fully close the propane tank valve and disconnect the LPG/propane hose from the generator when not in use.

1. Turn the generator OFF and place on a flat surface in a well ventilated area.
2. Verify that the propane tank valve is in the fully closed position.
3. Remove the cover on the generator propane inlet valve.
4. Use your fingers to hand thread the LPG/propane hose (included) to the propane inlet on the generator.

**IMPORTANT: DO NOT** use thread seal tape or any other type of sealant to seal the LPG/propane hose connection.

5. Tighten the LPG/propane hose connector to the generator with a 19 mm or adjustable wrench. **DO NOT** over-tighten.

**Torque: 5-10 lb-ft.**

6. Remove the safety plug or cap from the propane tank valve and attach the other end of the hose to the LPG/propane connector on the tank. Hand-tighten.
7. Turn the propane tank valve to the fully open position. Check all connections for leaks by wetting the fittings with a solution of soap and water. Bubbles which appear or bubbles which grow indicate that a leak exists. If a leak exists at a fitting, turn the propane tank valve to the fully closed position and tighten the fitting. Open the propane tank valve and recheck the fitting with the soap and water solution. If the leak continues or if the leak is not at a fitting then **DO NOT** use the generator and contact customer service.

## CONNECT THE BATTERY

1. Push down the battery access cover tab and pull the cover forward to remove it.



2. Verify that the rubber battery strap is firmly securing the battery in place. If loose, pull on the strap and hook it onto the mounting base.

**Note:** If the strap is loose behind the battery, remove the battery, reconnect the strap, replace the battery, then thread the strap under the battery quick connect cables.

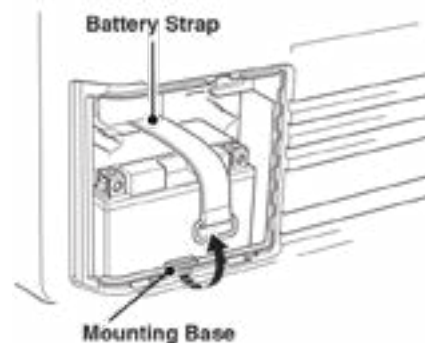

3. A quick-connect battery plug is pre-installed on the battery. Remove the cable tie securing the plugs then push firmly to connect them.

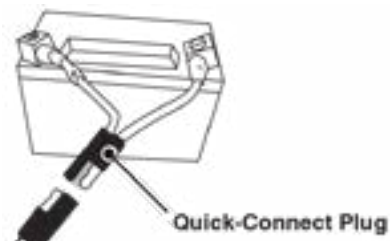

4. Align the tabs on the bottom of the battery access cover with the generator case then push to reinstall the cover.

**Note:** The generator is equipped with a battery charging feature. Once the engine is running, a small charge will slowly recharge the battery.

## OPERATION

### GENERATOR LOCATION

Read and understand all safety information before starting the generator.

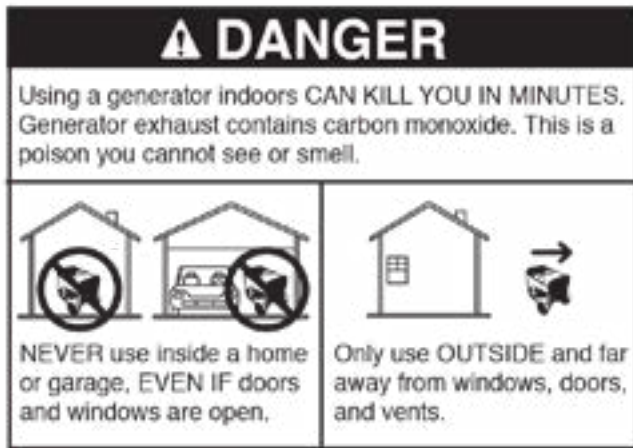

**NEVER** operate the generator inside any building, including garages, basements, crawlspaces, sheds, enclosure, or compartment, including the generator compartment of a recreational vehicle.

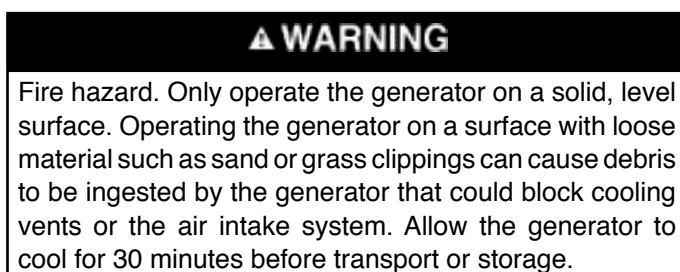
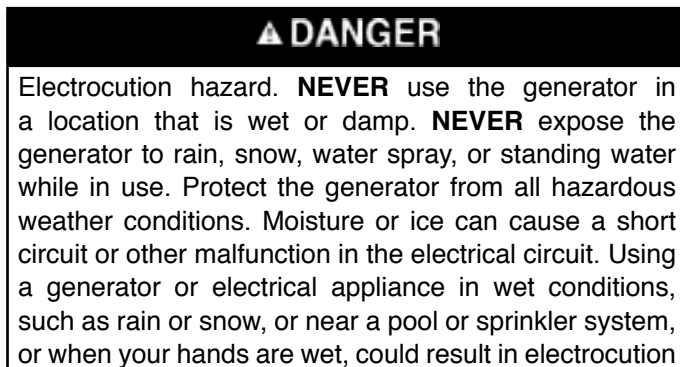

The generator should be on a flat, level surface at all times (Even while not in operation). The generator must have at least 5 ft. (1.5 m) of clearance from all combustible material.

**DO NOT** operate the generator in the back of a SUV, camper, trailer, truck bed (regular, flat, or otherwise), under stairs, next to walls or buildings, or in any other location that will not allow for adequate cooling of the generator and/or the muffler. **DO NOT** contain generators during operation.

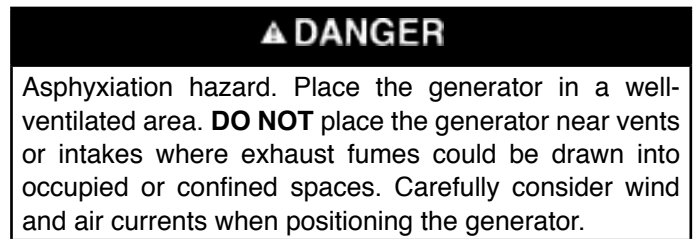

### GROUNDING

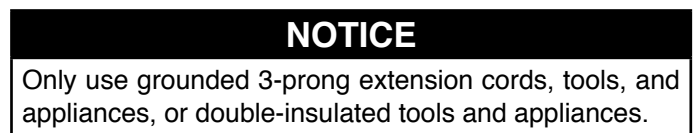
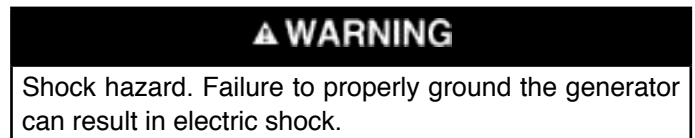

The generator neutral is floating. The generator ground terminal is connected to the frame of the generator, the metal non-current-carrying parts of the generator, and the ground terminals of each receptacle. The generator (stator winding) is isolated from the frame and from the AC receptacle ground pin. Electrical devices that require a grounded receptacle pin connection may not function properly.

If this generator will be used only with cord and plug equipment connected to the receptacles mounted on the generator, National Electric Code does not require that the unit be grounded. However, other methods of using the generator may require grounding to reduce the risk of shock or electrocution.

Before using the ground terminal, consult a qualified electrician, electrical inspector, or local agency having jurisdiction for local codes or ordinances that apply to the intended use of the generator.

### HIGH ALTITUDE OPERATION

Engine power is reduced the higher you operate above sea level. Output will be reduced approximately 3.5% for every 1000 feet of increased altitude from sea level.

High altitude adjustment is required for operation at altitudes over 5,000 ft. (1524 m). Operation without this adjustment will cause decreased performance, increased fuel consumption, and increased emissions.

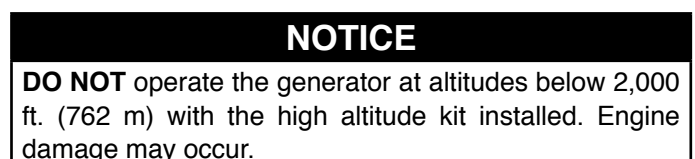

**High Altitude Carburetor Kit: Part# 518965**

**High Altitude DF Regulator: Part# 518516**

# OPERATION

**Note:** You must purchase both the Dual Fuel Regulator and Carburetor Kit for proper high altitude operation.

## REMOTE START

### ▲ WARNING

Verify that the area around the generator is clear before remote starting the generator.

The remote start key fob included with the generator should be attached to the recoil handle or control panel. If your unit was shipped without a key fob, contact Westinghouse customer service.

The generator can be started remotely from up to 99 feet (30 meter) using the remote start key fob.

**Note:** As the batteries in the remote start key fob drain, operational distance will decrease.

**Remote replacement batteries: (2) CR2016**

## REPROGRAMMING THE REMOTE START

If the remote start key fob is replaced or needs re-paired to the generator, follow this procedure.

1. Turn the generator battery switch to the ON position.
2. Push and hold the ON/OFF button for 10 seconds, then release. The start indicator light will flash green.

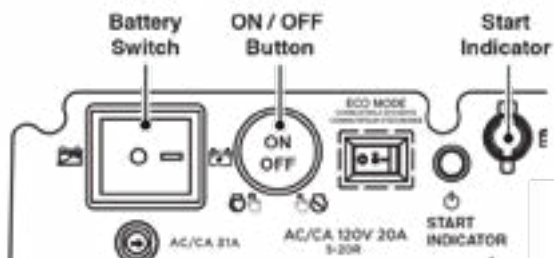

3. Push the ON button on the remote start key fob. It will pair with generator automatically and the start indicator light on the generator will stop flashing.



## FUEL SELECTOR SWITCH

Position the fuel selector switch on the front control panel to the desired fuel choice.

Turn the fuel selector switch fully upward for gasoline operation.



Turn the fuel selector switch fully downward for propane operation.



## BREAK-IN PERIOD

For proper break-in, **DO NOT** exceed 50% of the rated running watts (2250 watts) during the first five hours of operation. Vary the load occasionally to allow stator windings to heat and cool and help seat the piston rings.

## BEFORE STARTING THE GENERATOR

Verify that:

- The generator is placed in a safe, appropriate location.
- The generator is on a dry, flat, and level surface.
- The engine is filled with oil.
- All loads are disconnected.

### ▲ DANGER

Fire and explosion hazard. **DO NOT** move or tip the generator during operation.

## STARTING THE ENGINE: GASOLINE

1. Verify that fuel is in the gas tank.
2. Turn the fuel selector switch on the control panel to gasoline operation.
3. Turn the fuel tank valve to the ON position.

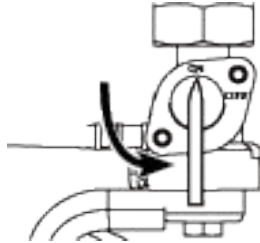

4. Push the Run/Stop switch to the Run position.
5. Firmly grasp and pull the recoil handle slowly until you feel increased resistance, then pull rapidly.

## STARTING THE ENGINE: PROPANE

### ▲ DANGER

Fire and explosion hazard. **ALWAYS** turn the propane tank valve to the fully closed position if not running the generator on propane.

1. Make sure the LPG/propane hose is correctly connected to the generator and propane tank.
2. Turn the fuel selector switch to propane operation.
3. Fully open the valve on the propane tank.
4. Push the Run/Stop switch to the Run position.
5. Firmly grasp and pull the recoil handle slowly until you feel increased resistance, then pull rapidly.

## SWITCHING FUEL SOURCES

### ▲ DANGER

Fire and explosion hazard. **DO NOT** add gasoline to the fuel tank or connect the LPG/propane hose to the generator while the generator is in operation.

The fuel source can be switched while the engine is running if a propane tank is connected to the generator **BEFORE** operation.

### GASOLINE TO PROPANE

**IMPORTANT:** Load capacity is reduced when running on propane. Make sure the generator can supply enough (running) and surge (starting) watts for the items you are powering before switching to propane.

1. Fully open the valve on the propane tank.
2. Turn the fuel selector switch to propane operation.
3. Turn the fuel tank valve to the OFF position.

### PROPANE TO GASOLINE

1. Turn the fuel tank valve to the ON position.
2. Turn the fuel selector switch to gasoline operation.
3. Turn the propane tank valve to the fully closed position.

**Note:** When switching to propane operation the engine may run rough for a few seconds while it purges gasoline in the carburetor.

If the engine stops when switching fuel sources, disconnect all loads then restart the unit on the fuel source of choice.

## STOPPING THE ENGINE

1. Turn off and unplug all connected electrical loads.

**IMPORTANT:** **NEVER** start or stop the generator with electrical devices connected.

2. Let the generator run with no load for several minutes to stabilize internal temperatures of the engine.
3. Push the Run/Stop switch to the Stop position.

**Note:** Alternately, if the generator is used infrequently, turn the fuel tank valve to the OFF position to limit the residual fuel remaining in the carburetor float bowl. The engine will stop when fuel in the carburetor and fuel line is exhausted.

4. If operating on propane, turn the propane tank valve to the fully closed position.

# OPERATION

## FREQUENCY OF USE

If the generator will be used on an infrequent or intermittent basis (more than one month before next use), refer to the Storage section of this manual for information regarding fuel deterioration.

## AC CIRCUIT BREAKERS

The circuit breakers will automatically switch OFF if there is a short circuit or a significant overload of the generator at each receptacle.

If an AC circuit breaker switches OFF automatically, check that the appliance is working correctly and it does not exceed the rated load capacity of the circuit before resetting the AC circuit breaker ON.



## ECO MODE

### NOTICE

Always start the generator with ECO MODE OFF. Allow the engine speed to stabilize and the OUTPUT READY LED to illuminate before switching ECO MODE ON.

**Note:** Do not use ECO MODE when in parallel operation with another Westinghouse generator.

ECO MODE minimizes fuel consumption and noise by adjusting the engine RPM to the minimum required for the current load.

Turn ECO MODE ON when powering small appliances with continuous loads such as a computer or electric light.

Turn ECO MODE OFF when powering large surge loads such as an air conditioner or electric pump.

To turn on ECO MODE, verify that the OUTPUT READY LED is illuminated green, then push the switch to the ON position. If no load is present, the generator RPM will drop to idle speed. The generator will detect loads as they are applied and increase engine RPM.

To run the generator at maximum power and RPM, push the ECO MODE switch to the OFF position.

## OVERLOAD RESET

The generator will automatically switch OFF all AC output to protect the generator if overloaded or if there is a short circuit in a connected appliance. However, the engine will continue to run. Marginal overloading that temporarily illuminates the OVERLOAD LED may shorten the service life of the generator.

OVERLOAD on the control panel will illuminate red and the green OUTPUT READY will be OFF.

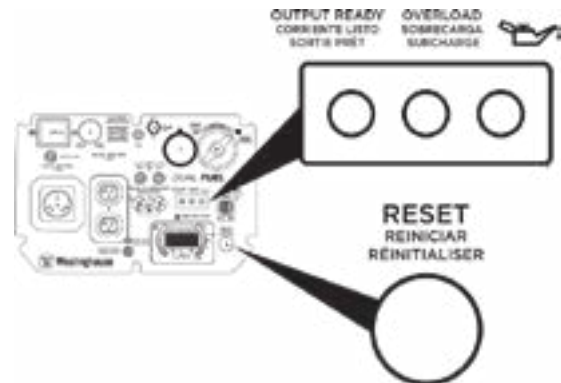

To restore AC output:

1. Turn off and unplug all connected electrical loads.
2. Push the RESET button on the control panel until the OVERLOAD LED goes OFF and the OUTPUT READY LED is illuminated.
3. Reset the circuit breakers if OFF.
4. Verify that the intended running and surge loads do not exceed the generator's capacity.
5. Reconnect electrical loads sequentially, allowing the generator to stabilize after each load is connected.



## GENERATOR CAPACITY

### NOTICE

**DO NOT** overload the generator's capacity. Exceeding the generator's wattage/amperage capacity can damage the generator and/or electrical devices connected to it.

Make sure the generator can supply enough continuous (running) and surge (starting) watts for the items you will power at the same time.

The total power requirements (Volts x Amps = Watts) of all appliances connected must be considered. Appliance and power tool manufacturers usually list rating information near the model or serial number.

To determine power requirements:

1. Select the items you will power at the same time.
2. Total the continuous (running) watts of these items. This is the amount of power the generator must produce to keep the items running. See the wattage reference chart.
3. Estimate how many surge (starting) watts you will need. Surge wattage is the short burst of power needed to start electric motor-driven tools or appliances such as a circular saw or refrigerator. Because not all motors start at the same time, total surge watts can be estimated by adding only the item(s) with the highest additional surge watts to the total rated watts from step 2.

#### Example:

Tool or Appliance	Running Watts*	Starting Watts*
RV Air Conditioner (11,000 BTU)	1010	1600
TV (Tube Type)	300	0
RV Refrigerator	180	600
Radio	200	0
Light (75 Watts)	300	0
Coffee Maker	600	0
	2590 Total Running Watts*	1600 Highest Starting Watts*
	Total Running Watts	2590
	Highest Starting Watts	+ 1600
	Total Starting Watts Needed	4190

\*Wattages listed are approximate. Verify actual wattage.

## POWER MANAGEMENT

To prolong the life of the generator and attached devices, use care when adding electrical loads to the generator. There should be nothing connected to the generator outlets before starting the engine. The correct and safe way to manage generator power is to sequentially add loads as follows:

1. With nothing connected to the generator, start the engine as described in this manual.
2. Plug in and turn on the first load, preferably the largest load you have.
3. Permit the generator output to stabilize (engine runs smoothly and attached device operates properly).
4. Plug in and turn on the next load.
5. Again, permit the generator to stabilize.
6. Repeat steps 4 and 5 for each additional load.

### Wattage Reference

Tool or Appliance	Estimated Running Watts*	Estimated Starting Watts*
Incandescent Lights (4 Quantity x 75 Watts)	300	0
TV (Tube Type)	300	0
Sump Pump (1/3 hp)	800	1300
Refrigerator or Freezer	700	2200
Well Pump (1/3 hp)	1000	2000
Furnace (1/2 hp)	800	2350
Radio	200	0
Drill (3/8", 4 amps)	440	600
Circular Saw (Heavy Duty, 7-1/4")	1400	2300
Miter Saw (10")	1800	1800
Table Saw (10")	2000	2000

\*Wattages listed are approximate. Verify actual wattage.

# OPERATION

## EXTENSION CORDS

### ▲ WARNING

Asphyxiation hazard. Extension cords running directly into the home increase the risk of carbon monoxide poisoning through any openings. If an extension cord running directly into your home is used to power indoor items, there is a risk of carbon monoxide poisoning to people inside the home. Always use battery-powered carbon monoxide detector (s) that meet current UL 2034 safety standards when running the generator. Regularly check the detector (s) battery.

### ▲ WARNING

Asphyxiation hazard. When operating the generator with extension cords, make sure the generator is located in an open, outdoor area, far away from occupied spaces with exhaust pointed away.

### ▲ WARNING

Fire and electrocution hazard. Never use worn or damaged extension cords. Damaged or overloaded extension cords could overheat, arc, and burn resulting in death or serious injury.

Before connecting an AC appliance or power cord to the generator:

- Use grounded 3-prong extension cords, tools, and appliances, or double-insulated tools and appliances.
- Make sure the tool or appliance is in good working order. Faulty appliances or power cords can create a potential for electric shock.
- Make sure the electrical rating of the tool or appliance does not exceed the rated power of the generator or the receptacle being used.

## EXTENSION CORD SIZING

Only use grounded 3-prong extension cords marked for outdoor use that are rated for the electrical load.

Total Amperage	Minimum Gauge, Outdoor Rated	
	Up to 50 FT (15 M)	Up to 100 FT (30 M)
Up to 10A	12	8
Up to 15A	10	8
Up to 20A	10	6
Up to 30A	8	6
Up to 35A	6	6

## PARALLEL OPERATION

### ▲ WARNING

Fire and electrocution hazard. Never connect or disconnect the parallel cord leads when a generator is running.

### NOTICE

Connecting the iGen4500DFc to a generator that is not compatible can cause a low voltage output that can damage tools and appliances powered by the generator.

Parallel operation gives you the ability to link the iGen4500DFc to a compatible Westinghouse Inverter Generator for combined running and peak power output. A Westinghouse parallel cord (purchased separately) is required for parallel operation. This cord can be purchased from an authorized Westinghouse Generator dealer.

**Note:** Do not use ECO MODE when in parallel operation with another Westinghouse generator.

**Parallel cord (50A/6000 Watts): Part# 507PC**

**Note:** Compatible Westinghouse generators without parallel ports can be operated in parallel with the receptacle-mounted parallel cable, Part# 260041.

1. Make sure the battery switch and the ECO MODE switch are in the OFF position.
2. Connect the black and red parallel cable leads to the black parallel ports on each corresponding generator control panel as shown below. Connect the black lead to the left port, the red lead to the right port.

**Note:** DO NOT connect two red leads or two black leads into the same generator.

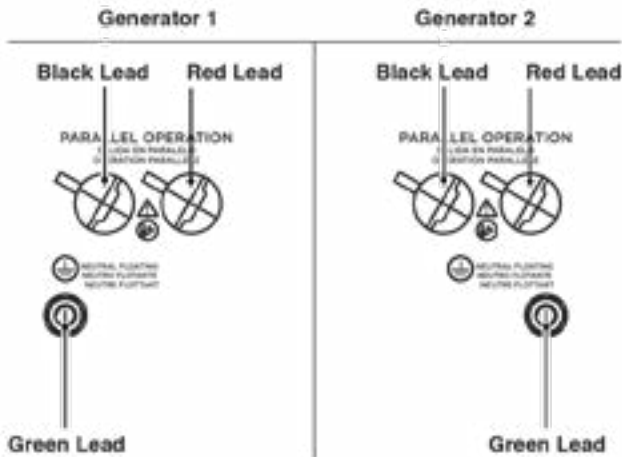

3. Connect the green ground lead to the ground terminal on each generator and tighten the nut.
4. Start one of the generators and wait until the OUTPUT READY LED illuminates.
5. Start the second generator and wait until the OUTPUT READY LED illuminates before connecting a load.
6. Connect additional loads as described in Power Management on page 18.
7. Unplug all loads before stopping the generators.

## TRANSPORTING

### ▲ CAUTION

Weight hazard. Always have assistance when lifting the generator.

- Allow the generator to cool a minimum of 30 minutes before transporting.
- If operating on LPG, turn the propane tank valve to the fully closed position.
- Disconnect the LPG/propane hose from the generator and propane tank.
- Replace all protective covers on the generator control panel.
- Only use the generator's fixed handle(s) to lift the unit or attach any load restraints such as ropes or tie-down straps. Do not attempt to lift or secure the generator by holding onto any of its other components.
- Keep the unit level during transport to minimize the possibility of fuel leakage or, if possible, drain the fuel or run the engine until the fuel tank is empty before transport.
- The generator wheels are only intended for hand transport. The wheels are not suitable for towing the generator either on or off-road.
- Use the extendable handle for one-person, hand transport. To deploy the handle, push on the locking button and pull on the handle until it's fully extended. To stow it, push on the locking button and push on the handle until it's fully retracted. Only extend or retract the handle while the generator is OFF, stationary, and resting on a horizontal surface. Do not use the extendable handle to lift the generator entirely off the ground, tow it, or up-end it.

### ▲ CAUTION



Fire hazard. Do not up-end the generator or place it on its side. Fuel or oil can leak and damage to the generator may occur.

# MAINTENANCE

## MAINTENANCE

### MAINTENANCE SCHEDULE

Regular maintenance will improve performance and extend the service life of the generator. Follow the hourly or calendar intervals, whichever occurs first. More frequent service is required when operating in adverse conditions as noted below.

<b>Before Each Use</b>
Check engine oil
<b>After First 25 Hours or First Month</b>
Change engine oil
<b>After 50 Hours or Every 6 Months</b>
Change engine oil <sup>1</sup> Clean air filter <sup>2</sup>
<b>After 100 Hours or Every 6 Months</b>
Inspect/clean spark arrestor Inspect/clean spark plug Replace fuel filter <sup>3</sup> Inspect/adjust valve clearance <sup>3</sup>
<b>After 300 Hours or Every Year</b>
Replace spark plug Replace air filter

- <sup>1</sup> Change oil every month when operating under heavy load or in high temperatures.
- <sup>2</sup> Clean more often under dirty or dusty conditions. Replace air filter if it cannot be adequately cleaned.
- <sup>3</sup> Recommend service to be performed by authorized Westinghouse service dealer.

### MAINTENANCE REPLACEMENT PARTS

Description	Part Number
Foam air filter	5691
Oil drain plug crush washer	94007
Spark arrestor	6790
Battery	511019
Spark plug	

### ENGINE SERVICE COVER

Remove the engine service cover to access the air filter, carburetor, and spark plug. Remove the cover screws then pull the cover straight out with both hands to prevent damage to the grommet posts on the cover.

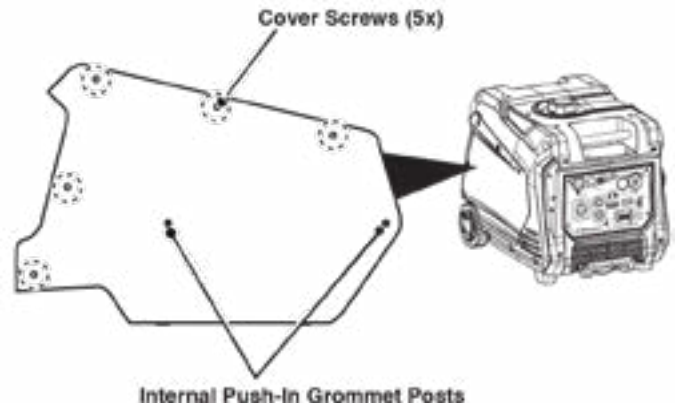

### AIR FILTER MAINTENANCE

#### ▲ WARNING

Fire hazard. Never use gasoline or other flammable solvents to clean the air filter. Use only household detergent soap to clean the air filter.

The air filter must be cleaned after every 50 hours of use or six months (frequency should be increased if the generator is operated in a dusty environment).

1. Place the generator on a level surface and allow the engine to cool for several minutes.
2. Remove the engine service cover.
3. Turn the knobs on the air cleaner cover to the unlocked position. Tip the cover down to remove.



**Note:** The air filter element is oil soaked. Use an appropriate cleaning container.

#### NOTICE

Avoid skin contact with engine oil. Wear protective clothing and equipment. Wash all exposed skin with soap and water.

- Remove the foam air filter from the air cleaner housing and wash it by submerging the element in a solution of household detergent soap and warm water. Slowly squeeze the foam to thoroughly clean.

## NOTICE

DO NOT twist or tear the foam air filter element during cleaning or drying. Only apply slow but firm squeezing action.

- Rinse the air filter element by submerging it in fresh water and applying a slow squeezing action. Allow the filter to dry thoroughly.



## NOTICE

Do not pollute. Follow the guidelines of the EPA or other governmental agencies for proper disposal of hazardous materials. Consult local authorities or reclamation facility.

- Dip the foam air filter in clean engine oil then squeeze out all excess oil. The engine will smoke when started if too much oil is left in the filter.
- Install the foam air filter in the housing and lock the air cleaner cover in place.
- Install the engine service panel.

**Air Filter: Part# 5691**

## ENGINE OIL LEVEL CHECK

### ▲ CAUTION

Avoid skin contact with engine oil. Wear protective clothing and equipment. Wash all exposed skin with soap and water.

## NOTICE

Always use the specified engine oil. Failure to use the specified engine oil can cause accelerated wear and/or shorten the life of the engine.

When using the generator under extreme, dirty, dusty conditions or in extremely hot weather, change the oil more frequently.

Ambient air temperature will affect engine oil performance. Change the type of engine oil used based on weather conditions.

Recommended Engine Oil Type									
		10W-30							
	5W-30						10W-40		
	5W-30 Synthetic								
°F	-20	0	20	40	60	80	100	120	
°C	-28.9	-17.8	-6.7	4.4	15.6	26.7	37.8	48.9	
Ambient temperature									

Check the engine oil level before each use or every 8 hours of operation.

- Place the generator on a level surface and allow the engine to cool for several minutes.
- Remove the oil access cover.
- With a damp rag, clean around the oil dipstick.
- Remove the oil dipstick and wipe the dipstick clean.

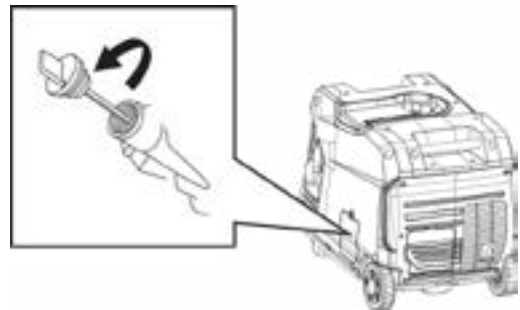

- Screw the dipstick fully into the filler neck. Remove the dipstick and verify that the oil level is within safe operating range.



- If low, add recommended engine oil incrementally and recheck until the level is between the L and H marks on the dipstick. DO NOT overfill. If over the full mark on dipstick, drain the oil to reduce oil level to the full mark on dipstick.
- Replace the oil dipstick and hand-tighten.
- Install the oil access cover.



# MAINTENANCE

## ENGINE OIL CHANGE

### ▲ WARNING

Accidental start-up. Remove the spark plug boot from the spark plug when working on the generator. Also remove the battery quick-connect plug from the battery.

When using the generator under extreme, dirty, dusty conditions or in extremely hot weather, change the oil more frequently. Change the oil while the engine is still warm from operation.

1. Place the generator on a level surface and allow the engine to cool for several minutes.
2. Remove the engine service cover. Disconnect the spark plug wire from the spark plug and place the wire where it cannot contact the spark plug.
3. Remove the oil access cover.
4. With a damp rag, clean around the oil dipstick. Remove the dipstick and wipe clean.
5. Remove the rubber plug under the oil drain bolt and place an oil pan (or suitable container) under the drain hole.
6. Using a 10mm wrench, remove the oil drain bolt and allow the oil to drain.

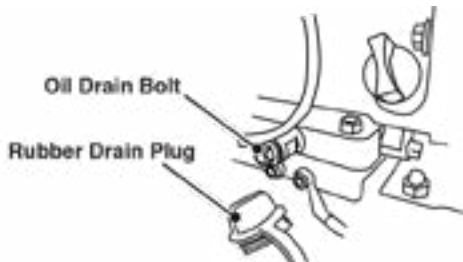

7. Install the oil drain plug and tighten securely. Install the rubber plug.

**Note:** A new oil drain plug crush washer is recommended at each oil change.

**Drain plug crush washer: Part# 94007**

8. Slowly pour oil into the oil fill opening until the level is between the L and H marks on the dipstick. Stop frequently to check the oil level. DO NOT overfill.

**Maximum oil capacity:** 0.63 US qt (0.60 L)

9. Replace the dipstick and hand-tighten.
10. Connect the spark plug wire and install the engine service cover.

### NOTICE

Do not pollute. Follow the guidelines of the EPA or other governmental agencies for proper disposal of hazardous materials. Consult local authorities or reclamation facility.

## SPARK PLUG MAINTENANCE

Inspect and clean the spark plug after every 100 hours of use or six months. Replace the spark plug after 300 hours of use or every year.

1. Place the generator on a level surface and allow the engine to cool.
2. Remove the engine service cover.
3. Remove the spark plug boot by firmly pulling the spark plug boot directly away from the engine.
4. Clean the area around the spark plug.
5. Remove the spark plug with the included spark plug socket wrench.

### NOTICE

Never apply any side load or move the spark plug laterally when removing the spark plug.

6. Inspect the spark plug. Replace if electrodes are pitted, burned, or the insulator is cracked. Only use a recommended replacement plug.

### Recommended Spark Plug Replacement

Westinghouse Model Number	Torch	NGK	Bosch	Autolite
iGen4500DFc	F7RTC	BPR7ES	WR5D	62

7. Measure the spark plug electrode gap with a wire-type feeler gauge. If necessary, correct the gap by carefully bending the side electrode.

**Spark plug gap:** 0.024 – 0.032 in. (0.60 – 0.80 mm)

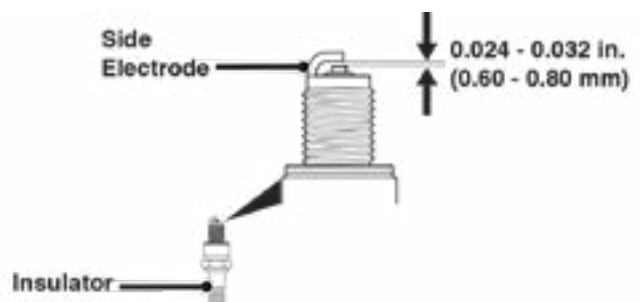

8. Carefully install the spark plug finger tight, then tighten as additional 3/8 to 1/2 turn with the spark plug wrench.
9. Install the spark plug boot and engine service cover.

## SPARK ARRESTOR SERVICE

Check and clean the spark arrestor after every 100 hours of use or six months. Failure to clean the spark arrestor will result in degraded engine performance.

1. Place the generator on a level surface and allow the muffler to cool before servicing the spark arrestor.
2. Remove the cover screws and the muffler cover. Use a screw driver to remove the spark arrestor.

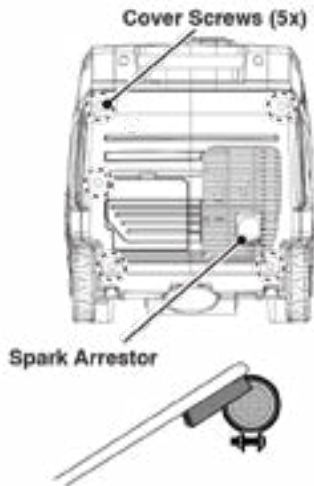

3. Carefully remove the carbon deposits from the spark arrestor screen with a wire brush. The spark arrestor must be free of breaks and tears. Replace the spark arrestor if damaged.

**Spark Arrestor: Part# 6790**

4. Reinstall the spark arrestor and muffler cover.

## BATTERY MAINTENANCE

The battery shipped with the generator has been fully charged. A battery may lose some charge when not in use for prolonged periods of time. If the battery is unable to crank the engine, plug the included 12V charger into the battery charging port on the control panel.

**Note:** If the generator is not run, charge the battery overnight once a month.

### ▲ CAUTION

The supplied battery charger is not a trickle charger and is not intended for continuous use. Do not use the battery charger for more than 8 hours (overnight) to prevent overcharging the battery.

**Note:** Once started, the generator will charge the battery after 30–60 minutes of use. If you do not regularly run the generator, charge the battery overnight once a month to keep it ready for use. Charge the battery in a dry location.

1. Plug the charger into the battery charging port on the control panel. Plug the wall receptacle end of the battery charger into a 120 Volt AC wall outlet.
2. Unplug the battery charger from wall outlet and control panel jack after 8 hours of charging.

## BATTERY REPLACEMENT

**Battery, 12V/6.5 Ah: Part# 511019**

### ▲ WARNING

Burn hazard. The battery contains sulfuric acid (electrolyte) which is highly corrosive and poisonous. Wear protective clothing and eye protection when working near the battery. Keep children away from the battery.

### ▲ CAUTION

Battery posts, terminals contain lead and lead compounds. Wash hands after handling.

1. Remove the battery access cover.
2. Remove the quick-connect plug and remove the battery strap. Remove the battery from the unit.
3. Disconnect the quick-disconnect cable leads from the battery.
4. On the replacement battery, connect the white (-) quick-connect cable to the battery negative terminal. Slide the rubber boot over the connection hardware.
5. Connect the red (+) quick-connect cable to the battery positive terminal. Slide the rubber boot over the connection hardware.
6. Lift the battery strap and install the battery into the generator. Thread the battery strap under the quick-connect cables and secure it on the mounting base.
7. Connect the quick-connect plug and install the battery access cover.

### NOTICE

Dispose of the used battery properly according to the guidelines established by your local or state government.

# MAINTENANCE

## STORAGE

Proper storage preparation is required for trouble-free operation and generator longevity.

### NOTICE

Gasoline stored for as little as 30 days can deteriorate, causing gum, varnish, and corrosive buildup in fuel lines, fuel passages and the engine. This corrosive buildup restricts the flow of fuel, which can prevent the engine from starting after a prolonged storage period. The use of fuel stabilizer significantly increases the storage life of gasoline. Full-time use of fuel stabilizer is recommended. Follow the manufacturer's instructions for use.

STORAGE TIME	RECOMMENDED PROCEDURE
Less than 1 month	No service required.
2 to 6 months	Fill with fresh gasoline and add gasoline stabilizer. Drain the carburetor float bowl.
6 months or longer	Drain the fuel tank and carburetor float bowl.

## SHORT TERM STORAGE

- Allow the generator to cool a minimum of 30 minutes before storage.
- If operating on LPG, turn the propane tank valve to the fully closed position and disconnect the LPG/propane hose from the generator and propane tank.
- Replace all protective covers on the generator control panel.
- Wipe the generator with a moist cloth. Clean any debris from the air inlets under the control panel and muffler cooling vents.
- Store the generator in a well-ventilated, dry location away from sparks, open flames, pilot lights, heat, and other sources of ignition such as areas with a spark-producing electric motor or where power tools are operated.
- Do not store the generator, gasoline, or propane tanks near furnaces, water heaters, or any other appliances that produce heat or have automatic ignitions.
- With the engine and exhaust system cool and all surfaces dry, cover the generator to keep out dust. Do not use a plastic sheet as a dust cover. Non-porous materials trap moisture and promote rust and corrosion.

## LONG TERM STORAGE

Even properly stabilized fuel can leave residue and cause corrosion if left long term. If storing the generator for two to six months, drain the float bowl to prevent gum and varnish buildup in the carburetor.

## DRAINING THE FLOAT BOWL

1. Remove the engine service cover.
2. Locate the drain hose extending from the bottom of the carburetor float bowl.

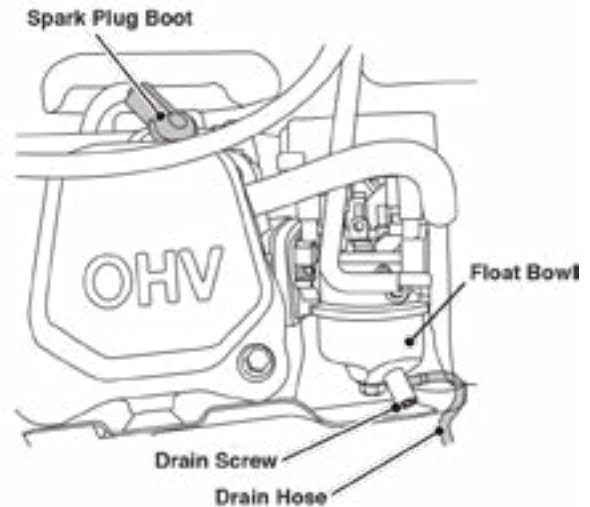

3. Place the loose end of the hose outside the generator into an approved gasoline container to catch the drained fuel.
4. Loosen the float bowl drain screw and allow the fuel to drain. Tighten the float bowl drain screw.
5. Route the drain hose between the air cleaner housing and the engine service cover. Install the engine service cover.

## DRAINING THE FUEL TANK

If storing the generator for longer than six months, drain the fuel tank to prevent fuel separation, deterioration, and deposits in the fuel system.

1. Unscrew the fuel tank cap. Remove the fuel screen filter by slightly compressing it while removing it from the tank.
2. Using a commercially available gasoline hand pump (not included), siphon the gasoline from the fuel tank into an approved gasoline container. DO NOT use an electric pump.
3. Reinstall the fuel screen filter and the fuel tank cap.
4. Start the generator and allow it to run until the generator engine stops.
5. Push the battery switch to the OFF position.
6. Disconnect the battery quick-connect plug.
7. Remove the spark plug.

8. Put a teaspoon of engine oil into the cylinder and pull the recoil handle until resistance is felt. At this position the piston is coming up on its compression stroke and both valves are closed. Storing the engine in this position will help prevent internal corrosion. Return the recoil handle gently.
9. Reinstall the spark plug. Leave the spark plug boot disconnected to prevent accidental starting.
10. Install the engine service cover.

5. Insert a feeler gauge between the rocker arm and the valve stem to measure valve clearance.

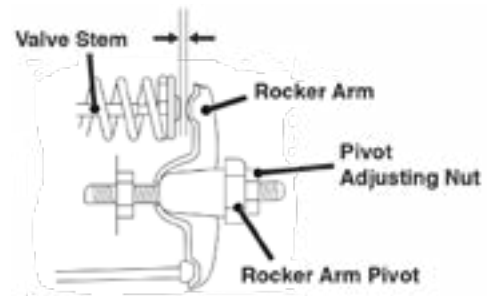

## VALVE CLEARANCE

### NOTICE

Checking and adjusting valve clearance must be done when the engine is cold.

1. Remove the rocker arm cover and carefully remove the gasket. If the gasket is torn or damaged, it must be replaced.
2. Remove the spark plug so the engine can be rotated more easily.
3. Rotate the engine to top dead center (TDC) by pulling the recoil handle slowly. Looking through the spark plug hole, the piston should be at the top (both valves are closed).
4. Both the rocker arms should be loose at TDC on the compression stroke. If they are not, rotate the engine 360°.

### Intake Valve

### Exhaust Valve

Valve Clearance	0.0031 – 0.0047 in (0.08 – 0.12 mm)	0.0051 – 0.0067 in (0.13 – 0.17 mm)
Torque	8-12 N•m	8-12 N•m

6. If an adjustment is necessary, hold the rocker arm pivot and loosen the pivot adjusting nut.
7. Turn the rocker arm pivot to obtain the specified clearance. Hold the rocker arm pivot and re-tighten the pivot adjusting nut to the specified torque.

**Torque: 106 inch-pound (12 N•m)**

8. Perform this procedure for the other valve.
9. Install the gasket, rocker arm cover, and spark plug.

# TROUBLESHOOTING

## TROUBLESHOOTING

PROBLEM	POSSIBLE CAUSE	CORRECTION
Engine will not start	Out of fuel.	Refuel.
	Bad fuel, generator stored without treating or draining gasoline, or refueled with bad gasoline.	Drain the fuel tank. Refuel with fresh gasoline.
	Dirty air filter.	Clean the air filter.
	Low engine oil level stopped generator.	Check engine oil level. Add engine oil if low.
	Spark plug wet with fuel (flooded engine).	Wait five minutes. Turn Run/Stop switch to the OFF position. Pull recoil handle rapidly several times. If the generator does not start, remove spark plug and dry.
	Spark plug faulty, fouled, or improperly gapped.	Gap or replace the spark plug. Reinstall.
	Fuel system malfunction, fuel pump failure, ignition malfunction, valves stuck, etc.	Contact Westinghouse customer service toll-free at 1 (855) 944-3571.
	CO sensor removed or modified	Return to original configuration
	CO sensor activated or system fault occurred	Relocate generator/ Contact Westinghouse customer service toll free at 1 (855) 944-3571.
Engine starts, then shuts down	Out of fuel.	Refuel.
	Incorrect engine oil level.	Check engine oil level.
	Dirty air filter.	Clean the air filter.
	Contaminated fuel.	Drain the fuel tank. Refuel with fresh gasoline.
	Defective low oil level switch.	Contact Westinghouse customer service toll-free at 1 (855) 944-3571.
Engine lacks power	Air filter restricted.	Clean or replace air filter.
	Bad fuel, generator stored without treating or draining gasoline, or refueled with bad gasoline.	Drain the fuel tank. Refuel with fresh gasoline.
	Fuel system malfunction, fuel pump failure, ignition malfunction, valves stuck, etc.	Contact Westinghouse customer service toll-free at 1 (855) 944-3571.
Engine runs rough or bogs when load applied	Dirty air filter.	Clean the air filter.
	Generator overloaded.	Unplug some devices.
	Faulty power tool or appliance.	Replace or repair tool or appliance. Stop and restart the engine.
	Fuel system malfunction, fuel pump failure, ignition malfunction, valves stuck, etc.	Contact Westinghouse customer service toll-free at 1 (855) 944-3571.
No power at AC receptacles	AC circuit breaker/s tripped.	Check AC loads and reset circuit breaker/s.
	Faulty power tool or appliance.	Replace or repair tool or appliance. Stop and restart the engine.
	Faulty generator.	Contact Westinghouse customer service toll-free at 1 (855) 944-3571.
Frost on the propane tank or regulator	If the temperature of the propane tank drops below the dew point, condensation on the tank may turn to frost or ice. This typically occurs in humid conditions.	Providing all the propane fuel handling equipment is functioning normally, no correction is needed.
	The Propane tank is not equipped with an Overfilling Prevention Device (OPD).	If you suspect your propane fuel tank is not equipped with an OPD device, discontinue operation immediately and replace the propane fuel tank with a propane tank equipped with a an OPD.
	Propane fuel tank overfilled.	If you suspect your propane fuel tank has been overfilled, discontinue operation immediately and return the propane fuel tank to the place of purchase or refilling.



# TROUBLESHOOTING

## TROUBLESHOOTING

PROBLEM	POSSIBLE CAUSE	CORRECTION
Propane fuel smell	Fuel regulator or fuel hose and fittings not securely sealed.	Using a soap solution check each connection and tighten as needed.
	Propane fuel regulator vent active.	The propane fuel regulator is equipped with a vent that will allow a small amount of propane fuel vapor to escape from the regulator when the propane tank valve is opened. This can be normal providing the venting of the propane is brief. If you suspect that this is abnormal, immediately discontinue use and have the propane regulator inspected by a qualified technician.
	Residual fuel from the carburetor dispersing after operation.	Normal, no correction is needed.
Poor performance or engine stalling on Propane	Propane fuel line kinked or crushed.	Inspect propane fuel line and remove kinks or other obstructions.
	Fuel selector valve not properly positioned.	Rotate the fuel valve fully until the pointer is directly in line with the desired fuel.
	Gasoline not purged from the carburetor before switching to propane.	Close the propane fuel tank valve. Move the fuel selector switch to gas. Start the engine and allow the engine to run until the gasoline has been consumed in the carburetor. Begin propane start up procedure.

# EXPLODED VIEWS

---

## EXPLODED VIEW AND PARTS LIST

### ENGINE EXPLODED VIEW

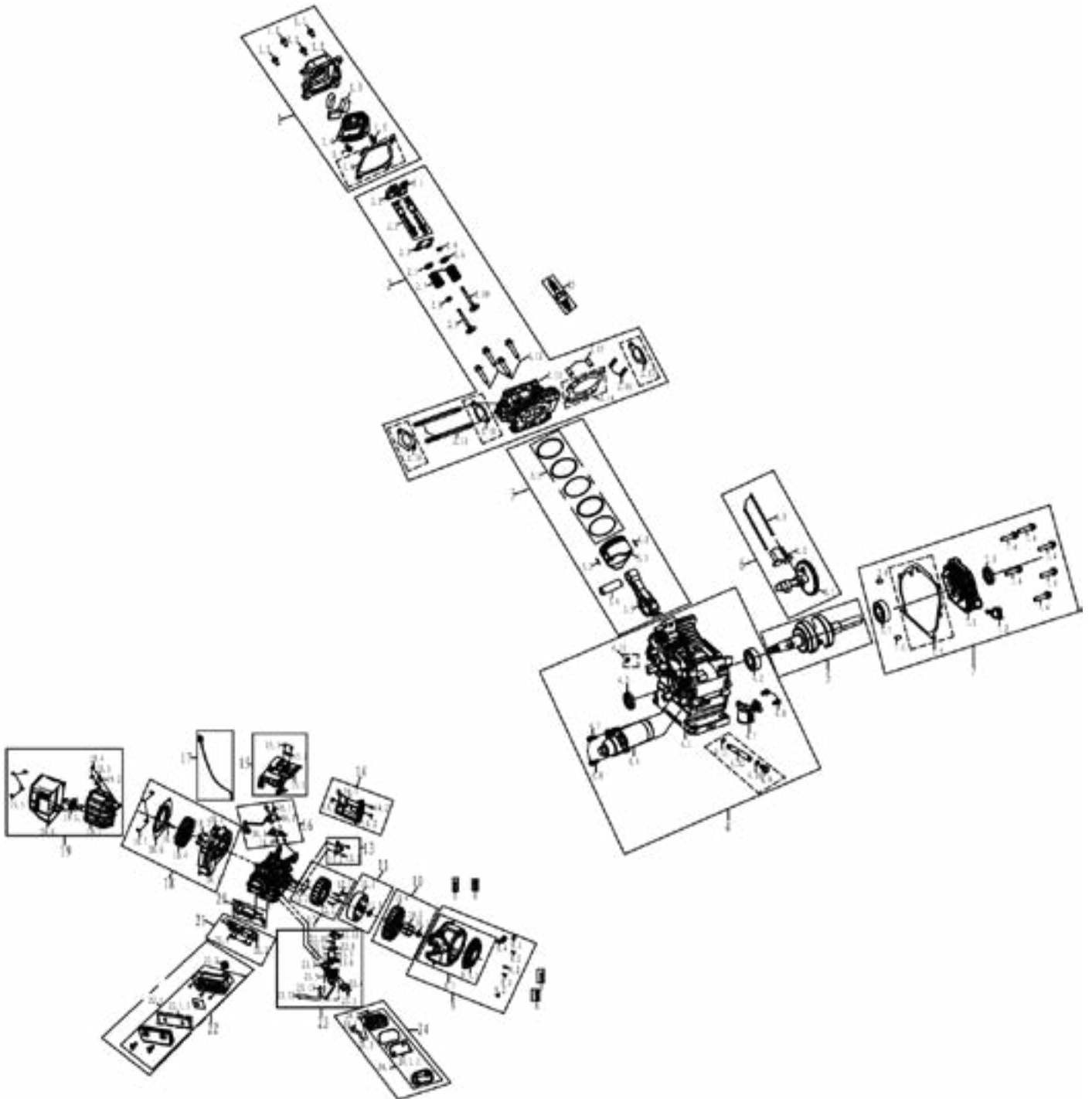

## ENGINE PARTS LIST

NO.	CODE	DESCRIPTION
1		CYLINDER HEAD COVER ASSEMBLY
1.1	91325	BOLT M6
1.2	241115	CYLINDER HEAD COVER
1.3	339915	POLYURETHANE SCREEN
1.4	241116	CYLINDER HEAD INTERNAL COVER
1.5	91322	BOLT M5
1.6	96200	CYLINDER HEAD COVER GASKET
2	50020041	CYLINDER HEAD KIT ASSEMBLY
2.1	242101	ROCKING ARM
2.2	91818	ROCKING ARM WITH TIGHT BOLT ASSEMBLY
2.3	242202	VALVE RETAINER ASSEMBLY
2.4	241804	TOP CAP
2.5	241801	INTAKE VALVE SPRING SEAT
2.6	241802	EXHAUST VALVE SPRING SEAT
2.7	246001	VALVE SPRING
2.8	241806	INTAKE VALVE SPRING LOWER SEAT
2.9	241704	INTAKE VALVE
2.10	245904	EXHAUST VALVE
2.11	91029	AIR INLET STUD BOLT
2.12	91359	BOLT M8
2.13	331001	CYLINDER HEAD
2.14	96058	CYLINDER HEAD GASKET
2.15	240905	CYLINDER HEAD LOCATING PIN
2.16	91007	AIR EXHAUST STUD BOLT
2.17	96055	EXHAUST GASKET
2.18	96182	INTAKE GASKET
2.19	96051	CARBURETOR GASKET
3		PISTON & PISTON RING ASSEMBLY
3.1	241607	PISTON RING ASSEMBLY
3.2	241301	PISTON PIN RING
3.3	241211	PISTON
3.4	245503	PISTON PIN
3.5	331500	CONNECTING ROD ASSEMBLY
4		CRANKCASE ASSEMBLY
4.1	330202	CRANKCASE
4.2	93010	BEARING
4.3	93507	CRANKCASE OIL SEAL
4.4	97447	STARTING MOTOR ASSEMBLY
4.5	91333	BOLT M6
4.6	91334	BOLT M6
4.7	245113	OIL SENSOR
4.8	91329	BOLT M6
4.9	91816	OIL DRAIN BOLT
4.10	94007	OIL DRAIN BOLT WASHER
4.11	94035	OIL DRAIN BOLT WASHER

NO.	CODE	DESCRIPTION
4.12	91831	OIL DRAIN SOLENOID
5	240364	CRANKSHAFT ASSEMBLY
6	50150005	CAMSHAFT ASSEMBLY
6.1	332003	CAMSHAFT ASSEMBLY
6.2	246103	VALVE LIFTER
6.3	241901	PUSH ROD
7	50200031	CRANKCASE COVER KIT ASSEMBLY
7.1	240116	CRANKCASE COVER
7.2	245601-276	DIPSTICK ASSEMBLY
7.3	93507	CRANKCASE OIL SEAL
7.4	91347	BOLT M8
7.5	96041	CRANKCASE GASKET
7.6	240904	CRANKCASE LOCATING PIN
7.7	93010	BEARING
8	599601	METAL CLIP
9		RECOIL STARTER ASSEMBLY
9.1	330501	RECOIL STARTER ASSEMBLY
9.1.1	5324	RECOIL COVER
9.2	91329	BOLT M6
9.3	500017-231	RECOIL HANDLE COVER
9.4	500018	RECOIL HANDLE
10		IMPELLER ASSEMBLY
10.1	91864	STARTER PULLEY COMPRESSION BOLT
10.2	334501	STARTER PULLEY
10.3	334601	IMPELLER
11	50760002	ROTOR KIT ASSEMBLY
11.1	90003	NUT M14
11.2	500191	ROTOR
12		STATOR ASSEMBLY
12.1	91400	BOLT M6
12.2	503410	STATOR
12.3	240904	CRANKCASE LOCATING PIN
13	50740002	TRIGGER KIT ASSEMBLY
13.1	91329	BOLT M6
13.2	339902	TRIGGER
14		WIND-LEAD-COVER ASSEMBLY
14.1	330503	WIND-LEAD-COVER
14.2	91325	BOLT M6
15	50620001	UPPER WIND DEFLECTORASSEMBLY
15.1	330502	UPPER WIND DEFLECTOR
15.2	249914	CRIMPING BLOCK
15.3	91325	BOLT M6
16		IGNITION COIL ASSEMBLY
16.1	91333	BOLT M6
16.2	339909	IGNITION COIL

# EXPLODED VIEWS

## ENGINE PARTS LIST CONTINUED

NO.	CODE	DESCRIPTION
16.3	339903	HIGH-VOLTAGE PACKAGE MOUNTING BRACKET
16.4	90016	NUT M6
17	335803	TEMPERATURE SENSOR
18	50630001	CENTRIFUGAL FAN HOUSING KIT ASSEMBLY
18.1	244306	CENTRIFUGAL FAN HOUSING
18.2	244304	CENTRIFUGAL FAN PLUG
18.3	91343	BOLT M8
18.4	244606	IMPELLER
18.5	91419	BOLT M8
18.6	334302	CENTRIFUGAL FAN COVER
18.7	91330	BOLT M6
19		EXHAUST MUFFLER ASSEMBLY
19.1	243782	MUFFLER
19.1.1	6790	SPARK ARRESTER
19.2	94216	FLAT WASHER
19.3	94206	SPRING WASHER
19.4	90011	NUT M8
19.5	91330	BOLT M6
19.6	500057	MUFFLER COVER
20	240511	SHIELD
21		BRACKET ASSEMBLY
21.1	91330	BOLT M6
21.2	249917	BRACKET
22		AIR FILTER ASSEMBLY
22.1	332901	AIR FILTER ASSEMBLY
22.1.1	5691	AIR FILTER
22.2	95918	CONNECTING PIPE
23		CARBURETOR ASSEMBLY
23.1	332301	CARBURETOR CONNECTION BLOCK
23.2	92219	SCREW M4
23.3	90016	NUT M6
23.4	94226	STEEL WASHER
23.5	332810	CARBURETOR ASSEMBLY
23.6	249925	STEPPER MOTOR BRACKET
23.7	92055	CROSS SCREW STUD M4
23.8	249949	STEPPER MOTOR
23.9	249950	STEPPER MOTOR
23.10	92240	CROSS SCREW STUD M4
23.11	249934	WATERPROOF COVER
23.12	517906	LOW PRESSURE HOSE
23.13	599302	LOW PRESSURE HOSE HOOP
24		RESONANT CAVITY ASSEMBLY
24.1	337001	RESONANT CAVITY ASSEMBLY
24.1.1	5697	FOAM FILTER

NO.	CODE	DESCRIPTION
24.2	249919	PLUG
24.3	95602	BREATHER TUBE
24.4	94407	FUEL LINE CLAMP
25	97109	SPARK PLUG



# EXPLODED VIEWS

## GENERATOR EXPLODED VIEW

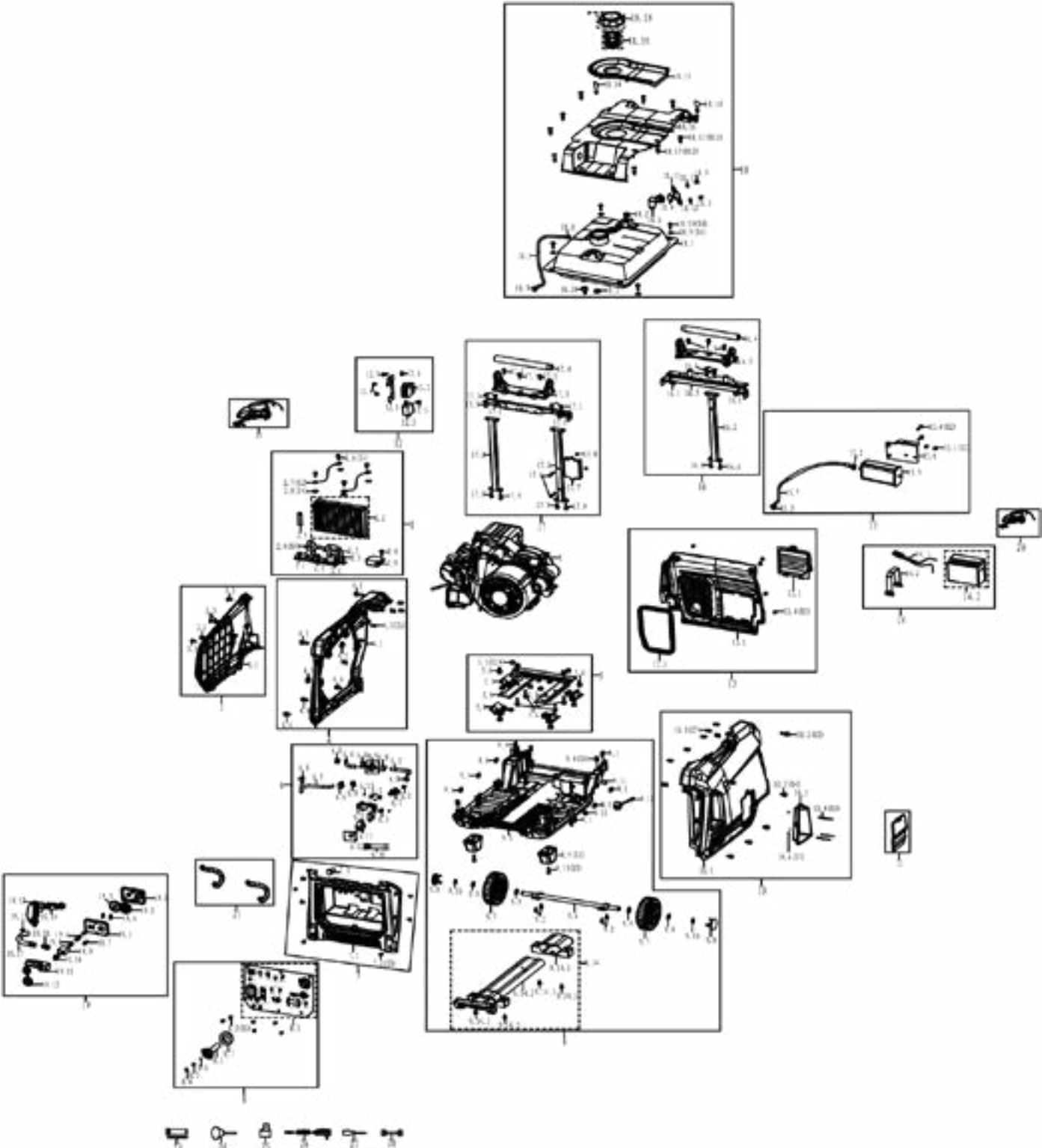

# EXPLODED VIEWS

## GENERATOR PARTS LIST

NO.	CODE	DESCRIPTION
1	1148224 220013	ENGINE ASSEMBLY DHLG225
2	100100007	INVERTER ASSEMBLY
2.1	91325	BOLT M6
2.2	503147	INVETER MODULE
2.3	503013	BRACKET
2.4	91322	BOLT M5
2.5	599601	METAL CLIP
2.6	91325	BOLT M6X12
2.7	500044	SHORT WIRE
2.8	94003	TOOTH WASHER
2.9	503048	DC VOLTAGE REGULATOR
3	100150006	LEFT PANEL ASSEMBLY
3.1	503039-221F	LEFT PANEL
3.2	92097	SCREW M6
3.3	92079	STOP BOLT M6
4		LEFT FRAME ASSEMBLY
4.1	503005-221	LEFT FRAME
4.2	91345	BOLT M8
4.3	500060	LOCK CLIP M6
4.4	92097	SCREW M6
4.5	500007	FUEL TANK ISOLATION PAD A
5		BRACKET ASSEMBLY
5.1	503001	BRACKET
5.2	503002	BRACKET
5.3	503003	BRACKET
5.4	503004	ISOLATION PAD
5.5	90044	NUT M8
5.6	91348	BOLT M8
6		BRACKET ASSEMBLY
6.1	91325	BOLT M6
6.2	503017	BRACKET
6.3	503772	FUEL LINE
6.4	503773	FUEL LINE
6.5	503020L	FUEL LINE
6.6	503044	CLIP
6.7	503062	FUEL SWITCH
6.8	503034	FUEL LINE CLAMP
6.9	516401	FILTER
6.10	503677	GAS CONTROL LINE
6.11	500242	CABLE TRAY
6.12	500011	FUEL SWITCH HOLDER
6.13	92014	SCREW
7		PANEL REAR COVER ASSEMBLY
7.1	503016	PANEL REAR COVER
7.2	92078	SCREW M6
7.3	505027	WIRE SLEEVE

NO.	CODE	DESCRIPTION
8	100110012	PANEL KIT ASSEMBLY
8.1	503802	PANEL ASSEMBLY
8.1.1	9222	ROCKER SWITCH
8.1.2	9227-31	THERMAL PROTECTOR
8.1.3	6404	WATERPROOF CAP
8.1.4	9223	ONE PUSH BUTTON SWITCH
8.1.5	9224	ECO SWITCH
8.1.6	9079	WATERPROOF CAP
8.1.7	9225	START INDICATOR
8.1.8	9226	CHARGING SOCKET
8.1.9	9227-30	THERMAL PROTECTOR
8.1.10	6404	WATERPROOF CAP
8.1.11	9227-20	THERMAL PROTECTOR
8.1.12	6404	WATERPROOF CAP
8.1.13	9228	IGNITER
8.1.14	9229	USB
8.1.15	503108	USB DUST COVER
8.1.16	9230	VOLTAGE RESET SWITCH
8.1.17	9235	LED
8.1.18	9232	PARRALLEL SOCKET
8.1.19	9122	WATERPROOF COVER
8.1.20	6032	L5-20R RECEPTACLE
8.1.21	9194	DUST COVER
8.1.22	9132	GROUNDING BOLT
8.1.23	6015	RV SOCKET
8.1.24	6849	DUST COVER
8.1.25	9236	CO WARNING LIGHT
8.1.26	9236	CO WARNING LIGHT
8.2	91825	SCREW & FLAT WASHER M5
8.3	503123	KNOB
8.4	500068	HANDLE PANEL PLUG
8.5	92032	SCREW M4
8.6	94325	FLAT WASHER
8.7	503310	KNOB PLUG
9		BASEBOARD ASSEMBLY
9.1	90027	SQUARE NUT
9.2	91325	BOLT M6
9.3	503045	BOTTOM PLATE
9.4	500060	LOCK CLIP M6
9.5	503026	ISOLATION PAD
9.6	503023	AXLE
9.7	503031	WHEEL
9.8	503032	WHEEL COVER
9.9	94022	STEEL WASHER
9.10	500321	AXLE WILD CARD
9.11	503053	LIMIT BLOCK

# EXPLODED VIEWS

## GENERATOR PARTS LIST CONTINUED

NO.	CODE	DESCRIPTION
9.12	503052	BASE OIL COVER
9.13	91334	BOLT M6
9.14	100310003	PULL ROD KIT ASSEMBLY
9.14.1	503033	PULL ROD SEAT
9.14.2	503035	PULL ROD
9.14.3	91334	BOLT M6X3
10	100280017	RIGHT FRAME KIT ASSEMBLY
10.1	503021-221F	RIGHT FRAME
10.2	91345	BOLT M8X20
10.3	500060	LOCK CLIP M6
10.4	503067	BLIND RIVET
10.5	503036-052	HANDLE DECORATIVE BOARD
10.6	94249	FLAT WASHER
10.7	92097	SCREW M6X20
11	503022-221	OBSERVATION COVER
12	100450001	CO MODULE ASSEMBLY
12.1	503807	CO MODULE BRACKET
12.2	599070	CO MODULE
12.3	599071	CO FLAMEOUT ACTUATOR
12.4	92328	BOLT M4
12.5	91325	BOLT M6
12.6	90016	NUT M6
13		MUFFLER PANEL ASSEMBLY
13.1	503027	MUFFLER PANEL
13.2	500108	MUFFLER EXHAUST SEALING STRIP
13.3	503040	COVER
13.4	92078	SCREW M6
14	100250003	BATTERY KIT ASSEMBLY
14.1	503165	BATTERY CABLE
14.2	599606	BATTERY TIE
14.3	511019	BATTERY
15		CARBON CANNISTER ASSEMBLY
15.1	91325	BOLT M6
15.2	94411	FUEL LINE CLAMP
15.3	94403	FUEL LINE CLAMP
15.4	91334	BOLT M6
15.5	543301L	CARBON CANISTER ASSEMBLY
15.6	503043	BRACKET
15.7	95016	CARBON CANISTER AND AIR FILTER CONNECTING PIPE
16		BRACKET ASSEMBLY
16.1	91325	BOLT M6
16.2	503006	LIFTER
16.3	503008	BRACKET
16.4	503009	HANDLE
16.5	503042	BRACKET

NO.	CODE	DESCRIPTION
16.6	91330	BOLT M6X20
17		BRACKET ASSEMBLY
17.1	91325	BOLT M6
17.2	503007	LIFTER
17.3	503008	BRACKET
17.4	503009	HANDLE
17.5	503011	BRACKET
17.6	91335	BOLT M6
17.7	503790	CONTROL MODULE
17.8	90010	NUT M6
17.9	91330	BOLT M6
18	100070011	FUEL TANK
18.1	503775	FUEL TANK
18.2	500008	FUEL TANK ISOLATION PAD
18.3	91322	BOLT M5
18.4	500252	SEALING RING
18.5	95127	CARBON CANISTER AND FUEL TANK CONNECTING PIPE
18.6	500247	GASOLINE SENSOR
18.7	94411	FUEL LINE CLAMP
18.8	94403	FUEL LINE CLAMP
18.9	96801	FUEL TANK GASKET
18.10	91397	BOLT M6
18.11	500244	PRESS PLATE
18.12	500324	SEALING WASHER
18.13	500068	HANDLE PANEL PLUG
18.14	503025	PLUG
18.15	503029	FUEL SLOT
18.16	503038-221	TOP COVER
18.17	92078	SCREW M6
18.18	503028	FUEL CAP
18.19	518801	FUEL TANK FILTER
18.20	503782	FUEL NOZZLE
19	100010004	PRESSURE REDUCING VALVE ASSEMBLY
19.1	503131	UPPER COVER
19.2	503134	GEAR
19.3	503133	GEAR
19.4	92007	SCREW M4
19.5	503132	LOWER COVER
19.6	503129	SWITCH AXIS
19.7	92019	SCREW M4
19.8	503130	O-RING
19.9	503128	TEE
19.10	503126	INTAKE CONNECTOR
19.11	503199	PROTECTIVE COVER
19.12	503136	PLUG

# EXPLODED VIEWS

---

## GENERATOR PARTS LIST CONTINUED

NO.	CODE	DESCRIPTION
19.13	50280014	PRESSURE REDUCING VALVE
19.14	545332	PRESSURE REDUCING VALVE
19.15	96120	GASKET
19.16	503127	OURLET CONNECTOR
19.17	517907	LOW PRESSURE HOSE
20	503805	DEPUTY WIRING HARNESS
21	503082	BELLOWS
22	503808	DEPUTY WIRING HARNESS
23	99011	SPARK PLUG SLEEVE
24	500942	FUNNEL
25	99629	OIL BOTTLE
26	511043	CHARGER
27	99506	DUAL - PURPOSE SCREWDRIVER
28	99585	FIXED WRENCH







[www.WestinghouseOutdoorPower.com](http://www.WestinghouseOutdoorPower.com)  
Service Hotline (855) 944-3571  
777 Manor Park Drive, Columbus, OH 43228

® and Westinghouse are trademarks of Westinghouse Electric Corporation.  
Used under license by Westinghouse Outdoor Power Equipment.  
© 2023 MWE Investments, LLC All Rights Reserved.