



WVT-881

KURZANLEITUNG / QUICK GUIDE

Outdoor Richtfunk 5GHz



Abb. unverbindlich

**Lieferumfang:**

- 1x WVT-881\*
- 1x Kurzanleitung und Sicherheitshinweise
- 1x Montagematerial

**Items included in the delivery:**

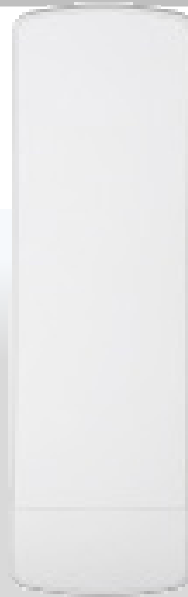
- 1x WVT-881\*
- 1x Quick installation guide and security note
- 1x Mounting material

**Besondere Ausstattungsmerkmale:**

- Richtfunk für Videoübertragung
- 5GHz Frequenzbereich
- Bis zu 300Mbit/s
- Bis zu 3km Reichweite
- Bis zu 40Mbit/s bei 3km

**Special features:**

- Long range wireless transceiver
- 5GHz frequency
- Up to 300Mbps
- Up to 3km transmission distance
- Up to 40Mbps at 3km

\*für den Betrieb einer Richtfunkstrecke werden zwei WVT-881 benötigt. Beachten Sie die lokalen Bestimmungen.

*\*Two WVT-881 are required for operating a directional radio link. Observe the local regulations.*



## Wichtige Sicherheitshinweise und Warnungen

Der folgende Inhalt befasst sich mit der ordnungs- und bestimmungsgemäßen Verwendung des Radars und der Vermeidung von Gefahren und Sachschäden während des Betriebs. Lesen Sie das Handbuch sorgfältig durch, bevor Sie das Radar benutzen, halten Sie sich strikt an das Handbuch und bewahren Sie es zum späteren Nachschlagen sorgfältig auf.

### Betriebsanforderungen

- Stellen oder installieren Sie das System nicht an einem Ort, der dem direkten Sonnenlicht ausgesetzt, oder in der Nähe einer Wärmequelle ist.
- Halten Sie das System von Feuchtigkeit, Staub oder Ruß frei um die Funktion zu sichern.
- Montieren Sie das System an einem stabilen Ort, damit es nicht herunterfallen kann.
- Lassen Sie keine Flüssigkeit auf ungeschützte Stellen des Systems tropfen oder spritzen.
- Betreiben Sie das System innerhalb des Nennbereichs der Leistungsaufnahme und -abgabe.
- Nehmen Sie das System nicht auseinander.
- Transportieren, verwenden und lagern Sie das System unter den zulässigen Feuchtigkeits- und Temperaturbedingungen.
- Sorgen Sie für einen ausreichenden Mindestabstand zu Objekten und Gegenständen im Erfassungsbereich

### Elektrische Sicherheit

- Verwenden Sie die in der Region empfohlenen Netzkabel und halten Sie sich an die Nennleistungsspezifikation.
- Verwenden Sie das mit dem System gelieferte Netzteil; andernfalls kann es zu Verletzungen von Personen und zu Geräteschäden kommen.

## Important safety warning

The following content deals with the proper and intended use of the radar and the avoidance of hazards and property damage during operation. Read the manual carefully before using the radar, strictly adhere to the manual and keep it in a safe place for future reference.

### Operating Requirements

- Do not place or install the system in a location exposed to direct sunlight, or near a heat source.
- Keep the system free from moisture, dust or soot to ensure proper operation.
- Mount the system in a stable place so that it cannot fall down.
- Do not allow liquid to drip or splash on unprotected areas of the system.
- Operate the system within the rated range of power input and output.
- Do not disassemble the system.
- Transport, use and store the system under the permissible humidity and temperature conditions.
- Ensure a sufficient minimum distance to objects and objects in the detection range.

### Electrical Safety

- Use the regionally recommended power cords and adhere to the rated power specification.
- Use the power supply provided with the system; failure to do so may result in personal injury and equipment damage.

## Technische Zeichnung / Technical drawing

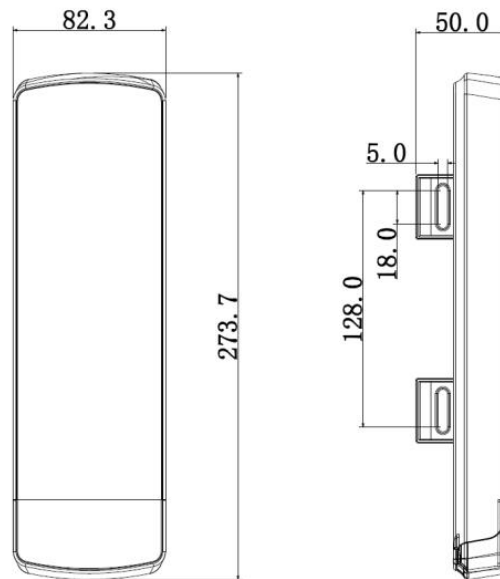

Alle Angaben in mm [inch]. Zeichnung nicht maßstabgerecht. Irrtum, technische Änderungen, geringe Maß- und Gewichtsabweichungen vorbehalten.

All dimensions in mm[inch]. Drawings not true to scale. We reserve the right to change technical specifications including slight variation in size and weight, technical changes, errors excepted.

## Spezifikation / Specifications

Wireless Features	
Wireless Standard	IEEE802.11 a/n
Working Frequency	5745~5825MHz(extended range: 4920~6100MHz)
Wireless Speed	300Mbps
Modulation Mode	OFDM
Antenna	Built-in antenna: gain 15dBi
Output Power	27dBm (max)
Receiving Sensitivity	-74dBm@65Mbps, -96dBm@1Mbps
Transmission Distance	0-3KM
Wireless Direction Angle	Horizontal 40°, vertical 15°
Hardware	
Power	1*PoE RJ45(IN: 220V, OUT: 24V/0.5A);
Power Consumption	Max. 8W
Ethernet Port	1*LAN RJ45 + 1*LAN RJ45 from passive PoE adapter
Indicator Light	Wi-Fi status indicator light / LAN port indicator light / Power indicator light / Signal intensity indicator light
Working Temperature	-30°C ~ +70°C
Storage Temperature	-30°C ~ +80°C
Working Humidity	5% ~ 95%RH(no condensation)
Equipment Dimension	280mmx30mmx80mm
Equipment Weight	0.45Kg
Mast Diameter	40mm~60mm

Software	
Encryption Type	WEP/WPA-PSK/WPA2/CCMP(AES)/TKIP
Network Mode	Route/Network Bridge
Working Mode	Access Point/Client/WDS AP/WDS client/WDS Repeater
Security Mechanism	IP/MAC address filtering, hide network name, etc.
Network Protocol	TCP/UDP/ARP/ICMP/DHCP/HTTP/NTP
TDMA Enhancement	Support(TDMA eliminate hidden nodes influence and greatly improve one-to-many performance)
Auto ACK Timing Adjustment	Support(Auto optimize parameter within long-distance communication and make the performance optimal)
Management and Log	NTP, SNMP, Syslog, Telnet
Webpage Configuration Management	Support webpage configuration
Firmware Update	Support firmware webpage update
Long-Distance Communication Throughput Rate	≤40Mbps@3km
Bandwidth Flexible	5M/10M/20M/40MHz

## Schematischer Aufbau / Line connection

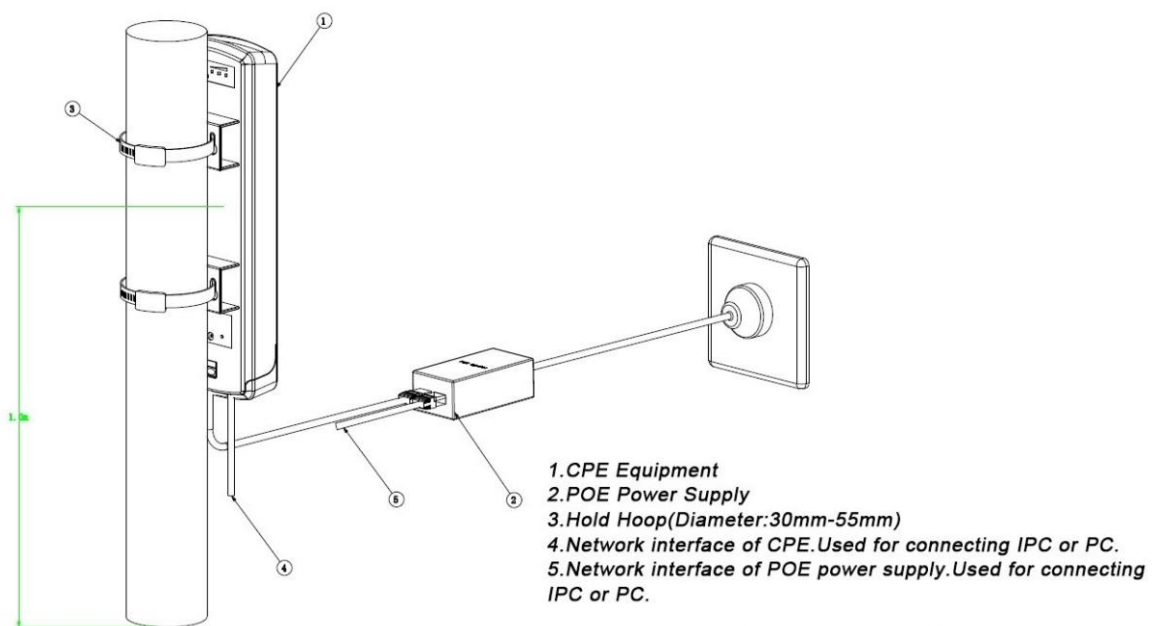

Note: the recommended installation height is 4m, and no barrier between two points. The actual installation height is determined by the installation environment.

## Port Beschreibung / Port description

Port	Beschreibung	Description
POE	Versorgen Sie den WVT-881 mit 24V Versorgung und Datenübertragung durch Anschluss von Twisted-Pair mit POE-Port.	Provide WVT-881 with 24V power supply and data transmission by connecting twisted-pair with POE port.
LAN	Kann verwendet werden, um die IP-Kamera genau wie den "LAN"-Anschluss anzuschließen, Sie können einen der beiden LAN-Anschlüsse wählen, um das Debugging des Geräts durchzuführen	Can be used to connect IP camera just like "LAN" port, can choose either LAN port to do the device debugging.

## System Beispiel / Example

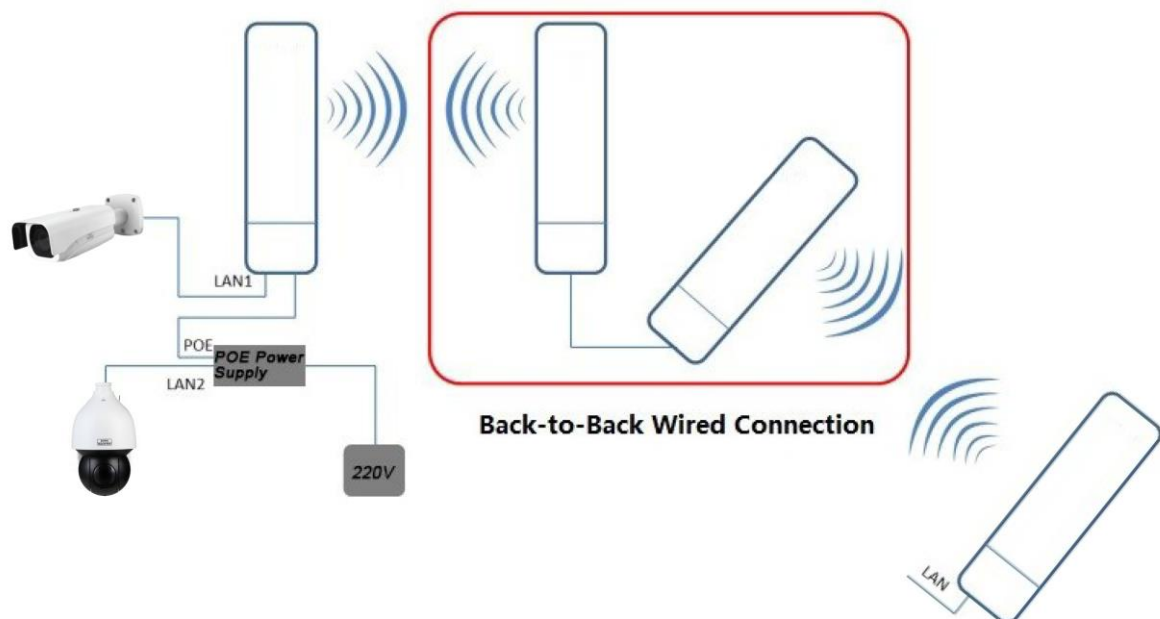

### Inbetriebnahme

- Installieren Sie das System am gewünschten Ort.
- Schließen Sie das System an die Betriebsspannung / PoE an.
- Installieren Sie den IP-Finder und öffnen Sie das Webinterface des Systems
  - **Username: admin**
  - **Password: admin**

Download IP-Finder: [Link](#)

### Getting started

- *Install the system in the desired location.*
- *Connect the system to power / PoE.*
- *Install the IP-Finder and open devices webinterface*
  - **Username: admin**
  - **Password: admin**

Download IP-Finder: [Link](#)

www.Santec-Video.de ► Downloads & Software ► SANTEC IP-Finder & Config Tool

Schritt 1 Konfigurieren Sie die Host-IP-Adresse mit "192.168.1.x "(x kann nicht 36 sein)  
Zum Beispiel 192.168.1.180

Step 1 Configure host IP address with "192.168.1.x "(x can't be 36)  
For example 192.168.1.180

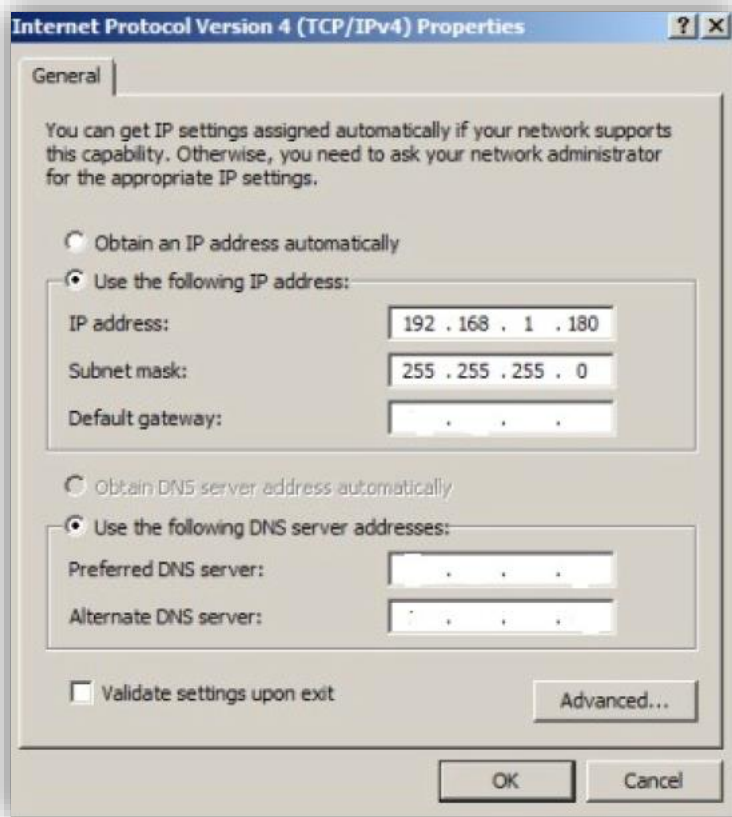

Schritt 2 Geben Sie die Standard-IP-Adresse 192.168.1.36 des WVT-881-Geräts in den Browser ein, das System öffnet die Startseite.

Step 2 Enter the default IP address 192.168.1.36 of WVT-881 equipment in the browser, the system will display login page.

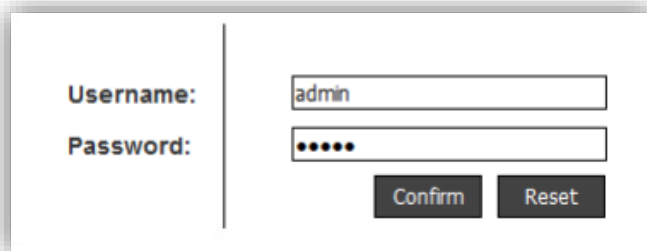

Schritt 3 Geben Sie den Benutzernamen und das Passwort ein (der Standardwert für Benutzernamen und Passwort ist admin) und klicken Sie auf "Confirm". Das System zeigt die Seite der Statusanzeige an, die den Betriebszustand des Geräts, die aktuelle Einstellung, die Softwareversion und einige andere grundlegende Informationen enthält.

Step 3 Enter user name and password (the default of both user name and password is admin), click "login". The system displays the page of status display, which includes the equipment's working condition, current setting, software version and some other basic information.

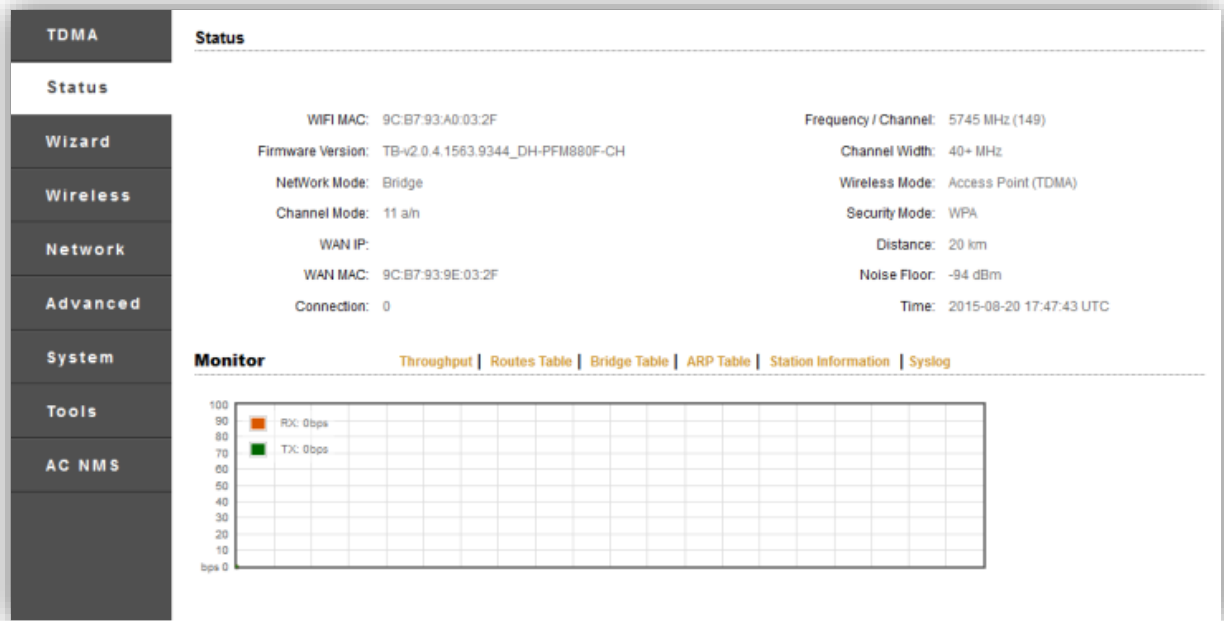

Schritt 4 Klicken Sie auf der linken Seite auf "Setup-Assistent", der dem Benutzer helfen kann, das Gerät sehr schnell zu konfigurieren schnell zu konfigurieren, z. B. Netzwerk-konfiguration, Wireless-Modus usw. Sie können auf die entsprechende Konfigurationsseite aufrufen, indem Sie auf das Menü links auf der Seite klicken. Es werden grundlegende Netzwerkparameter-Konfiguration angezeigt. Die Standardkonfiguration des Geräts ist "Bridge Mode", die IP-Adresse des LAN-Ports ist "192.168.1.36", daher wird den Benutzern dringend empfohlen, die IP-Adresse zu ändern, sobald sie das Gerät anmelden. Hinweis: Die IP-Adresse des Geräts ist innerhalb desselben LANs eindeutig, achten Sie also darauf, die IP Adresse entsprechend dem Design zu ändern und sicherzustellen, dass die IP-Adresse innerhalb desselben Netzwerks nicht in Konflikt gerät.

Step 4 Click "setup wizard" on the left, which can help users to configure the equipment very quickly, such as network configuration, wireless mode and etc. You can also enter the corresponding configuration page by clicking the menu on the left side of the page. It will display basic network parameter configuration. The equipment default configuration is "Bridge Mode", the IP address of LAN port is "192.168.1.36", so the users are strongly advised to modify the IP address as soon as they login the equipment.

Note: The equipment IP is unique within the same LAN, so pay attention to modify the IP address according to the design and make sure IP won't conflict within the same network.

**TDMA**

**Status**

**Wizard**

**Wireless**

**Network**

**Advanced**

**System**

**Tools**

**AC NMS**

**Network**

This wizard page helps to set the basic network parameters, please click the left "Network" menu for detail setting.

Bridge Mode    LAN IP: 192.168.1.36    LAN Netmask: 255.255.255.0

Next

Schritt 5 Klicken Sie auf "Weiter" und es werden die grundlegende Konfiguration der drahtlosen Parameter und die Optionen für die drahtlose Verschlüsselungsoptionen. Die beiden am häufigsten verwendeten Drahtlos-Modi von Geräten sind "Client" und "Access Point". Innerhalb desselben LAN sollte der Server in Übereinstimmung mit der drahtlosen Verschlüsselungsoption, der Netzwerknamenoption und der Passwort Option des drahtlosen Client-Geräts übereinstimmen.

Anmerkung:

Im "Station"-Modus wird das Gerät, das die Kameraseite verbindet, im Allgemeinen im Client-Modus betrieben.

Step 5 Click "Next" and it will display basic wireless parameter configuration and wireless encryption options. Two most commonly used wireless modes of equipment are "Client" and "Access Point". Within the same LAN, the server should be in accordance with wireless encryption option, network name option and password option demand of client wireless device.

Note:

Under "Station" mode, the equipment which connects camera end is generally set as client mode.



<b>TDMA</b>	<b>Wireless</b>
<b>Status</b>	Your current country code is Compliance Test. If you want to change country code, please click the wireless menus left side to change. This wizard page helps to set the basic wireless and wireless security. Please click the left "Wireless" menu for detail setting.
<b>Wizard</b>	
<b>Wireless</b>	Wireless Mode: Access Point SSID: MySSID Output Power: High Frequency, MHz: 5745 MHz (149) Channel Width: 40+ MHz Wireless Security(?): WPA WPA2-PSK Key: [masked] <input type="checkbox"/> Show
<b>Network</b>	
<b>Advanced</b>	
<b>System</b>	
<b>Tools</b>	
<b>AC NMS</b>	<input type="button" value="Last"/> <input type="button" value="Next"/>

Schritt 6 Klicken Sie auf "Weiter" und es wird die Seite "Wizard-Finish" angezeigt.

Step 6 Click "Next" and it will display "Wizard-Finish" page.

<b>TDMA</b>	<b>Wizard-Finish</b>
<b>Status</b>	You have finished the wizard. Please click "Change" to save all your settings, and click "Apply" to reboot and make your settings work.
<b>Wizard</b>	
<b>Wireless</b>	<input type="button" value="Last"/> <input type="button" value="Change"/>
<b>Network</b>	
<b>Advanced</b>	
<b>System</b>	
<b>Tools</b>	
<b>AC NMS</b>	



Schritt 7 Klicken Sie auf die Schaltfläche "Ändern", um alle Einstellungen zu speichern, und dann auf die Schaltfläche "Übernehmen", damit Ihre Einstellungen übernommen werden. Sie können auch auf "Last" klicken, um die vorherige Konfiguration zu ändern.

Step 7 Click "Change" button to save all the settings, then click "Apply" button to make your settings valid. You can also click "Last" to modify previous configuration.

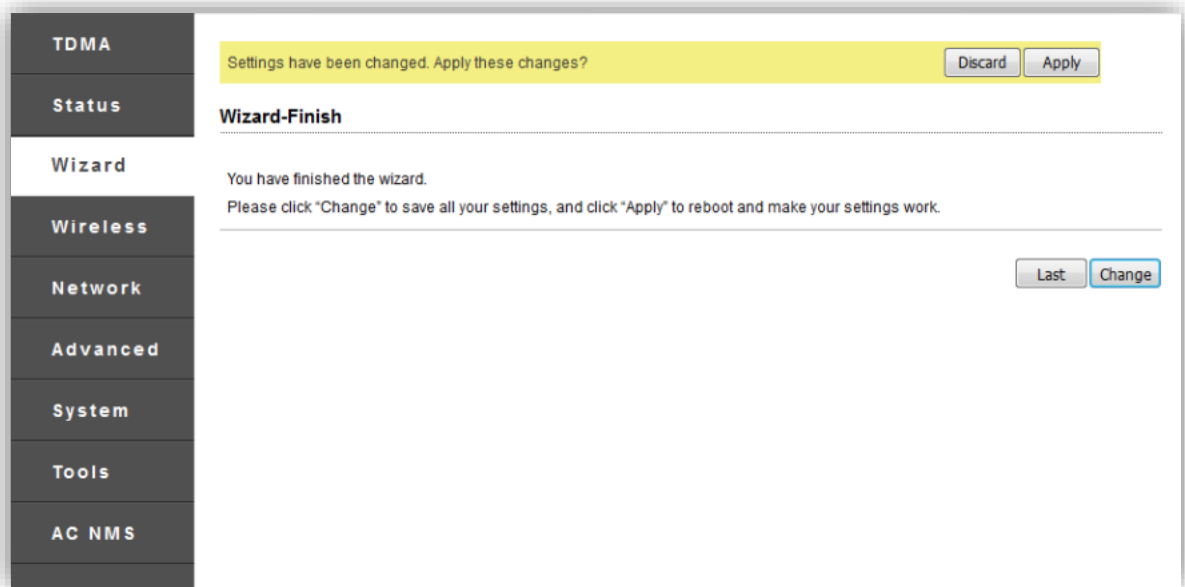

## Cyber Security Information

Die BURG-WÄCHTER KG folgt der branchenüblichen Praxis bei der Produkt- / Softwareprüfung und dem Umgang mit gefundenen Schwachstellen von Produkten und Produktsoftware, um das Risiko für Kunden zu minimieren. Leider kann für eine vollständige Sicherheit von Produkten, Software und Diensten, die nach bestem Wissen und Gewissen erstellt und geprüft werden, eine vollständige Fehlerfreiheit, die nicht von möglicherweise böswilligen Angreifern überwunden werden kann, nicht gänzlich garantiert werden. Dies betrifft nicht nur BURG-WÄCHTER Geräte, sondern vielmehr die Allgemeinheit von vernetzbaren Geräten die über Kommunikationsschnittstellen und Dienste verfügen. Die BURG-WÄCHTER KG kann garantieren, dass wir uns bemühen das Risiko auf ein Minimum zu reduzieren.

Die Behebung von Schwachstellen ist ein fortlaufender Prozess, da immer neue Schwachstellen, u.a. in Netzwerkprotokollen und Diensten, gefunden werden und nicht gänzlich ausgeschlossen werden können.

Bei Fragen zum Produkt oder dessen Einrichtung wenden Sie sich bitte an: [camera-service@burg.biz](mailto:camera-service@burg.biz)

## Cyber security information

*The BURG-WÄCHTER KG follows the industry-standard practice of dealing with found product weaknesses and product software in order to minimize the risk for customers. Unfortunately, for complete security of products, software and services that are created and verified to the best of our knowledge and belief, complete freedom from errors that can't be overcome by potentially malicious attackers can't be fully guaranteed. This does not only apply to devices of BURG-WÄCHTER devices, but rather to the generality of networkable devices. BURG-WÄCHTER can guarantee that we try to reduce the risk to a minimum.*

*Fixing vulnerabilities is an ongoing process because there are always new vulnerabilities, e.g. in network protocols and services, and can't be completely excluded.*

*If you have any questions, please contact [camera-service@burg.biz](mailto:camera-service@burg.biz)*

## DSGVO Hinweis

Beim Einsatz von Videosicherheitssystemen werden personenbezogene Daten in automatisierter Form erhoben, verarbeitet und genutzt. Derartige Daten stehen unter dem Schutz der DSGVO, die als EU-Verordnung direkt in Deutschland Anwendung findet. Verantwortlich für den Betrieb und die Verarbeitung der Daten ist der Betreiber der Anlage. Bei der Installation der Videosicherheitsanlage sind geeignete technisch-, organisatorische Maßnahmen zur Wahrung der Persönlichkeitsrechte Betroffener zu ergreifen.

## GDPR information

When using video security systems, personal data is collected in an automated manner, processed and used. Such data are under the protection of the GDPR, which is direct as an EU regulation. The operator of the system is responsible for the operation and processing of the data. When installing the video security system, appropriate technical and organizational measures must be taken to safeguard the personal rights of those affected.

## Allgemeine Sicherheitshinweise

- Vor Inbetriebnahme des Gerätes sollte dieses Handbuch sorgfältig gelesen und als Nachschlagewerk verwahrt werden.
- Vor jeder Reinigung muss das Gerät ausgeschaltet und von der Betriebsspannung getrennt werden. Benutzen Sie für die Reinigung ein feuchtes Tuch. Benutzen Sie keine scharfen Reinigungsmittel oder Sprühdosen. Das Typenschild darf nicht ersetzt werden.
- Benutzen Sie keine Zusatzgeräte, die nicht vom Hersteller des Gerätes empfohlen wurden. Diese können die Funktionalität des Gerätes beeinflussen und schlimmstenfalls Verletzungen und einen elektrischen Schlag herbeiführen oder sogar Feuer auslösen.
- Betreiben Sie das Gerät niemals in der Nähe von Wasser oder anderen Flüssigkeiten.
- Das Gerät sollte an einem sicheren Ort und auf fester Unterlage gemäß den Angaben des Herstellers installiert werden. Schweres Gerät sollte mit großer Sorgfalt transportiert werden. Schnelle Halts, übermäßige Krafteinwirkungen und unebener Boden können die Ursache sein, dass das Gerät zu Boden fällt und schweren Schaden an Personen und anderen Objekten verursacht.
- Eventuell am Gerät befindliche Öffnungen dienen der Entlüftung und schützen das Gerät vor Überhitzung. Diese Öffnungen dürfen niemals zugedeckt oder zugestellt werden. Sorgen Sie dafür, dass das Gerät nicht überhitzt wird.
- Verwenden Sie nur die empfohlene Betriebsspannungsversorgung. Wenn Sie nicht sicher sind, ob die am Installationsort vorhandene Stromversorgung verwendet werden kann, fragen Sie Ihren Händler.
- Ein Gerät, das von einer polarisierten Stromversorgung versorgt wird, hat meistens als Sicherheitsvorkehrung einen Netzanschlusstecker mit unterschiedlichen Klinken, welche nur auf eine Art und Weise mit der Netzsteckdose verbunden werden können. Versuchen Sie niemals, diese Sicherheitsvorkehrung eines polarisierten Steckers außer Betrieb zu setzen.
- Wenn das Gerät eine Stromversorgung mit Erdungsanschluss erfordert, dann sollte es auch nur an eine entsprechende Netzsteckdose mit Erdungsanschluss angeschlossen werden. Steht eine solche Schukosteckdose nicht zur Verfügung, dann sollte sie von einem Elektriker installiert werden.
- Anschlusskabel sollten so verlegt werden, dass man nicht darauf treten kann oder dass sie durch herab fallende Gegenstände beschädigt werden können.
- Bei einem Gewitter oder bei längerer Nutzungspause sollte das Gerät immer von der Betriebsspannung getrennt werden. Lösen Sie auch andere Kabelverbindungen. Auf diese Weise schützen Sie das Gerät vor Blitzschäden oder Stromstößen.
- Setzen Sie Netzsteckdose und Netzkabel niemals einer Überbelastung aus. Feuer und elektrische Schläge können die Folge sein.
- Stecken Sie niemals Gegenstände durch die Öffnungen des Geräts. Sie können Spannungs- führende Teile berühren und einen elektrischen Schlag erhalten.
- Vergießen Sie auch niemals Flüssigkeiten über das Gerät.
- Bei Betriebsstörungen oder einem vollständigen Betriebsausfall schalten Sie das Gerät aus und trennen es von der Versorgungsspannung. Versuchen Sie niemals, selbst Wartungs- oder Reparaturarbeiten bei geöffnetem Gehäuse durchzuführen, da Sie sich gefährlichen Spannungen aussetzen. Überlassen Sie Wartungs- oder Reparaturarbeiten ausschließlich qualifizierten Fachwerkstätten.
- Als Ersatzteile dürfen nur Teile verwendet werden, die vom Hersteller zugelassen wurden oder solche, die identische Leistungsdaten aufweisen. Nicht genehmigte Ersatzteile können zu Schäden an Personen (elektrischer Schlag) und Gerät (Feuer) führen.
- Nach jeder Wartung oder Reparatur des Geräts muss das Gerät auf einwandfreien Betrieb überprüft werden.
- Die Installation des Geräts darf nur von qualifiziertem Personal ausgeführt werden und muss den örtlichen Spezifikationen und Vorschriften entsprechen, beachten Sie die Datenschutz Grundverordnung.
- Bei Einsatz dieser Kamera an Orten mit stark unterschiedlichen Lichtverhältnissen ist die Blendeneinstellung anzupassen.
- Bitte beachten Sie im Fall der Entsorgung unbrauchbarer Geräte die geltenden gesetzlichen Vorschriften.



Dieses Symbol bedeutet, dass elektrische und elektronische Geräte am Ende ihrer Nutzungsdauer vom Hausmüll getrennt entsorgt werden müssen. Bitte entsorgen Sie das Gerät bei Ihrer örtlichen kommunalen Sammelstelle.



Bei Kameras mit einem IR-Scheinwerfer:  
Bewahren Sie stets einen Abstand von > 1m, um gesundheitlichen Schäden vorzubeugen.  
Schauen Sie nie direkt in den IR-Scheinwerfer hinein, um Augenschäden zu vermeiden.

### CE Richtlinien

Vorsicht: Änderungen und Modifizierungen, die nicht ausdrücklich durch die zuständige Genehmigungsbehörde genehmigt worden sind, können zum Entzug der Genehmigung zum Betreiben des Gerätes führen. Dieses Gerät entspricht den CE-Richtlinien.

## General safety precautions and safety instructions

- Before operating the appliance, please read this manual carefully and retain it for further reference.
- Before cleaning the appliance, it has to be switched off and unplugged from the power outlet. Wipe the appliance with a soft damp cloth.  
Do not use harsh cleansers or aerosols for cleaning. The type label may not be replaced.
- Do not use attachments unless recommended by the manufacturer as they may affect the functionality of the appliance and result in the risk of fire, electric shock or injury.
- Never install the appliance in areas exposed to water or other liquids.
- The appliance has to be installed in a safe and stable location which is able to carry the weight of the appliance. Quick stops, excessive force, and uneven surfaces may cause the appliance to fall causing serious injury to persons and damage to objects.
- Openings in the appliance, if any, are provided for ventilation to ensure reliable operation of the appliance and to protect it from overheating. These openings must not be covered or blocked. Please make sure that the appliance does not overheat.
- The appliance should only be operated from the type of power source indicated on the marking label. If you are not sure of the type of power supplied at the installation location, please contact your local dealer.
- An appliance which is powered through a polarized plug (a plug with one blade wider than the other) will fit into the power outlet only one way. This is a safety feature. If you are unable to insert the plug into the outlet, try reversing the plug. Do not defeat the safety purpose of the polarized plug.
- If the appliance is powered through a grounding-type plug, the plug will only fit into a grounding-type power outlet. This is a safety feature. If your outlet does not have the grounding plug receptacle, contact your local electrician.
- Route power cords and cables in a manner to protect them from damage by being walked on or pinched by items placed upon or against them.
- For protection of the appliance during a lightning storm or when it is left unattended and unused for a longer period, unplug the appliance from the wall outlet. Disconnect any antennas or cable systems that may be connected to the appliance. This will prevent damage to the appliance due to lightning or power-line surges.
- Do not overload wall outlets and extension cords as this can result in a risk of fire or electric shock.
- Never insert items into the openings of the appliance. They may touch parts under electric current which may cause an electric shock.
- Never pour any liquids over the appliance.
- In case of any operating interruption or a complete operating failure please switch off the appliance and disconnect it from the wall outlet. Never attempt to service or repair the appliance yourself, as opening or removing covers may expose you to dangerous voltage or other hazards. Refer all servicing to qualified service personnel.
- When replacement parts are required, be sure that the service technician uses replacement parts specified by the manufacturer or that have the same characteristics as the original part. Unauthorized substitutions may result in fire, electric shock or other hazards.
- Upon completion of any service or repairs to the appliance, ask the service technician to perform safety checks to verify that the appliance is in proper operating condition.
- The appliance must only be installed by qualified service personnel and has to comply with local specifications and regulations, e.g. GDPR.
- At the installation site, the camera has to be adjusted to the given light conditions (see OSD).
- Please respect the local legal regulations on waste if you need to dispose of discarded appliances.



This symbol means that electrical appliances need to be disposed of properly and not simply with unsorted household refuse. Please respect local regulations on waste disposal.



For cameras equipped with IR LEDs:  
Please make sure to always keep a distance of > 1m to avoid damages to your health. Never look directly into the IR-LEDs – this may cause eye damages!

### CE compliance

Attention: Any changes or modifications to this appliance which have not been explicitly approved of by the respective regulatory authority, may lead to a prohibition of usage of this appliance. This appliance complies with the CE guidelines.



## GNU GPL Lizenzhinweis

Beachten Sie, dass dieses Produkt u.a. Open Source Software enthält, welche unter der GNU General Public License (GPL) lizenziert ist. Wir verweisen auf die Lizenzbestimmungen der GPL, um eine GPL-konforme Verwendung der Programme sicherzustellen.

Der ausgedruckte Lizenztext der GPL V2 liegt diesem Produkt bei.  
Der Lizenztext der GPL kann auch von der Homepage unter

[www.santec-video.com/Download/GNU\\_GPL/GNU\\_GPL\\_V2.pdf](http://www.santec-video.com/Download/GNU_GPL/GNU_GPL_V2.pdf)

heruntergeladen werden.

Sie und jeder Dritte erhalten auf Anfrage den vollständigen und maschinenlesbaren Open Source Quellcode der unter der GPLv2 lizenzierten Software. Der Quellcode kann entweder als kostenfreie Download-Link oder alternativ auf einem üblichen Datenträger (zu Selbstkosten) zur Verfügung gestellt werden. Dieses Angebot ist gültig für einen Zeitraum von drei Jahren ab dem Zeitpunkt, zu dem Sie die Software heruntergeladen haben bzw. ab dem Zeitpunkt, zu dem wir das Produkt versendet haben.

Bitte richten Sie Ihre entsprechende Anfrage an:

SANTEC BW AG  
Wormgermühle  
58540 Meinerzhagen  
Deutschland

Tel: +49 2358 905 490  
Fax: +49 2358 905 4490  
E-Mail: camera-service@burg.biz

Bitte beachten Sie, dass wir keinen Support oder Garantie für die Fehlerfreiheit des Quellcodes geben können. Der Quellcode stellt lediglich einen Teil der Gesamtsoftware dar.

## GNU GPL License note

*Certain open source components are licensed pursuant to GNU General Public License. This establishes that the customers have the right to acquire, modify and redistribute the source code of said software in accordance with the terms of the GNU General Public License or Lesser General Public License.*

*A printed copy of the license text GPL V2 is included in this product shipment.  
The license text can also be downloaded from our homepage at*

[www.santec-video.com/Download/GNU\\_GPL/GNU\\_GPL\\_V2.pdf](http://www.santec-video.com/Download/GNU_GPL/GNU_GPL_V2.pdf)

*You as well as any other third party may request to have access to the complete and machine-readable open source code for the GPLv2 licensed software. The source code can be provided as free-of-charge download link or, alternatively, on a common data storage device (at cost price). This offer is valid for up to three years after you downloaded the software or after the product has been shipped to you.*

*Please send your request to the following address:*

SANTEC BW AG  
Wormgermühle  
58540 Meinerzhagen  
Germany

Tel: +49 2358 905 490  
Fax: +49 2358 905 4490  
E-Mail: camera-service@burg.biz

*We can't give support or guarantee for squeaky-cleanliness of source codes. The source codes are only a part of whole software.*

## GNU General Public License

Version 2, June 1991

This page mirrors the text from <http://www.gnu.org/licenses/gpl-2.0.html>.

Copyright © 1989, 1991 Free Software Foundation, Inc.

51 Franklin Street, Fifth Floor, Boston, MA 02110-1301, USA

Everyone is permitted to copy and distribute verbatim copies of this license document, but changing it is not allowed.

### Preamble

The licenses for most software are designed to take away your freedom to share and change it. By contrast, the GNU General Public License is intended to guarantee your freedom to share and change free software—to make sure the software is free for all its users. This General Public License applies to most of the Free Software Foundation's software and to any other program whose authors commit to using it. (Some other Free Software Foundation software is covered by the GNU Lesser General Public License instead.) You can apply it to your programs, too.

When we speak of free software, we are referring to freedom, not price. Our General Public Licenses are designed to make sure that you have the freedom to distribute copies of free software (and charge for this service if you wish), that you receive source code or can get it if you want it, that you can change the software or use pieces of it in new free programs; and that you know you can do these things. To protect your rights, we need to make restrictions that forbid anyone to deny you these rights or to ask you to surrender the rights. These restrictions translate to certain responsibilities for you if you distribute copies of the software, or if you modify it. For example, if you distribute copies of such a program, whether gratis or for a fee, you must give the recipients all the rights that you have. You must make sure that they, too, receive or can get the source code. And you must show them these terms so they know their rights. We protect your rights with two steps:

(1) copyright the software, and (2) offer you this license which gives you legal permission to copy, distribute and/or modify the software.

Also, for each author's protection and ours, we want to make certain that everyone understands that there is no warranty for this free software. If the software is modified by someone else and passed on, we want its recipients to know that what they have is not the original, so that any problems introduced by others will not reflect on the original authors' reputations.

Finally, any free program is threatened constantly by software patents. We wish to avoid the danger that redistributors of a free program will individually obtain patent licenses, in effect making the program proprietary. To prevent this, we have made it clear that any patent must be licensed for everyone's free use or not licensed at all. The precise terms and conditions for copying, distribution and modification follow.

### TERMS AND CONDITIONS FOR COPYING, DISTRIBUTION AND MODIFICATION

0. This License applies to any program or other work which contains a notice placed by the copyright holder saying it may be distributed under the terms of this General Public License. The "Program", below, refers to any such program or work, and a "work based on the Program" means either the Program or any derivative work under copyright law: that is to say, a work containing the Program or a portion of it, either verbatim or with modifications and/or translated into another language. (Hereinafter, translation is included without limitation in the term "modification".) Each licensee is addressed as "you".

Activities other than copying, distribution and modification are not covered by this License; they are outside its scope. The act of running the Program is not restricted, and the output from the Program is covered only if its contents constitute a work based on the Program (independent of having been made by running the Program). Whether that is true depends on what the Program does.





1. You may copy and distribute verbatim copies of the Program's source code as you receive it, in any medium, provided that you conspicuously and appropriately publish on each copy an appropriate copyright notice and disclaimer of warranty; keep intact all the notices that refer to this License and to the absence of any warranty; and give any other recipients of the Program a copy of this License along with the Program.

You may charge a fee for the physical act of transferring a copy, and you may at your option offer warranty protection in exchange for a fee.

2. You may modify your copy or copies of the Program or any portion of it, thus forming a work based on the Program, and copy and distribute such modifications or work under the terms of Section 1 above, provided that you also meet all of these conditions:

1. You must cause the modified files to carry prominent notices stating that you changed the files and the date of any change.
2. You must cause any work that you distribute or publish, that in whole or in part contains or is derived from the Program or any part thereof, to be licensed as a whole at no charge to all third parties under the terms of this License.
3. If the modified program normally reads commands interactively when run, you must cause it, when started running for such interactive use in the most ordinary way, to print or display an announcement including an appropriate copyright notice and a notice that there is no warranty (or else, saying that you provide a warranty) and that users may redistribute the program under these conditions, and telling the user how to view a copy of this License. (Exception: if the Program itself is interactive but does not normally print such an announcement, your work based on the Program is not required to print an announcement.)

These requirements apply to the modified work as a whole. If identifiable sections of that work are not derived from the Program, and can be reasonably considered independent and separate works in themselves, then this License, and its terms, do not apply to those sections when you distribute them as separate works. But when you distribute the same sections as part of a whole which is a work based this License, whose permissions for other licensees extend to the entire whole, and thus to each and every part regardless of who wrote it.

Thus, it is not the intent of this section to claim rights or contest your rights to work written entirely by you; rather, the intent is to exercise the right to control the distribution of derivative or collective works based on the Program.

In addition, mere aggregation of another work not based on the Program with the Program (or with a work based on the Program) on a volume of a storage or distribution medium does not bring the other work under the scope of this License.

3. You may copy and distribute the Program (or a work based on it, under Section 2) in object code or executable form under the terms of Sections 1 and 2 above provided that you also do one of the following:

1. Accompany it with the complete corresponding machine-readable source code, which must be distributed under the terms of Sections 1 and 2 above on a medium customarily used for software interchange; or,
2. Accompany it with a written offer, valid for at least three years, to give any third party, for a charge no more than your cost of physically performing source distribution, a complete machine-readable copy of the corresponding source code, to be distributed under the terms of Sections 1 and 2 above on a medium customarily used for software interchange; or,
3. Accompany it with the information you received as to the offer to distribute corresponding source code. (This alternative is allowed only for noncommercial distribution and only if you received the program in object code or executable form with such an offer, in accord with Subsection b above.)



The source code for a work means the preferred form of the work for making modifications to it. For an executable work, complete source code means all the source code for all modules it contains, plus any associated interface definition files, plus the scripts used to control compilation and installation of the executable. However, as a special exception, the source code distributed need not include anything that is normally distributed (in either source or binary form) with the major components (compiler, kernel, and so on) of the operating system on which the executable runs, unless that component itself accompanies the executable.

If distribution of executable or object code is made by offering access to copy from a designated place, then offering equivalent access to copy the source code from the same place counts as distribution of the source code, even though third parties are not compelled to copy the source along with the object code.

4. You may not copy, modify, sublicense, or distribute the Program except as expressly provided under this License. Any attempt otherwise to copy, modify, sublicense or distribute the Program is void, and will automatically terminate your rights under this License. However, parties who have received copies, or rights, from you under this License will not have their licenses terminated so long as such parties remain in full compliance.

5. You are not required to accept this License, since you have not signed it. However, nothing else grants you permission to modify or distribute the Program or its derivative works. These actions are prohibited by law if you do not accept this License. Therefore, by modifying or distributing the Program (or any work based on the Program), you indicate your acceptance of this License to do so, and all its terms and conditions for copying, distributing or modifying the Program or works based on it.

6. Each time you redistribute the Program (or any work based on the Program), the recipient automatically receives a license from the original licensor to copy, distribute or modify the Program subject to these terms and conditions. You may not impose any further restrictions on the recipients' exercise of the rights granted herein. You are not responsible for enforcing compliance by third parties to this License.

7. If, as a consequence of a court judgment or allegation of patent infringement or for any other reason (not limited to patent issues), conditions are imposed on you (whether by court order, agreement or otherwise) that contradict the conditions of this License, they do not excuse you from the conditions of this License. If you cannot distribute so as to satisfy simultaneously your obligations under this License and any other pertinent obligations, then as a consequence you may not distribute the Program at all. For example, if a patent license would not permit royalty-free redistribution of the Program by all those who receive copies directly or indirectly through you, then the only way you could satisfy both it and this License would be to refrain entirely from distribution of the Program.

If any portion of this section is held invalid or unenforceable under any particular circumstance, the balance of the section is intended to apply and the section as a whole is intended to apply in other circumstances.

It is not the purpose of this section to induce you to infringe any patents or other property right claims or to contest validity of any such claims; this section has the sole purpose of protecting the integrity of the free software distribution system, which is implemented by public license practices. Many people have made generous contributions to the wide range of software distributed through that system in reliance on consistent application of that system; it is up to the author/donor to decide if he or she is willing to distribute software through any other system and a licensee cannot impose that choice.

This section is intended to make thoroughly clear what is believed to be a consequence of the rest of this License.

8. If the distribution and/or use of the Program is restricted in certain countries either by patents or by copyrighted interfaces, the original copyright holder who places the Program under this License may add an explicit geographical distribution limitation excluding those countries, so that distribution is permitted only in or among countries not thus excluded. In such case, this License incorporates the limitation as if written in the body of this License.



9. The Free Software Foundation may publish revised and/or new versions of the General Public License from time to time. Such new versions will be similar in spirit to the present version, but may differ in detail to address new problems or concerns.

Each version is given a distinguishing version number. If the Program specifies a version number of this License which applies to it and “any later version”, you have the option of following the terms and conditions either of that version or of any later version published by the Free Software Foundation. If the Program does not specify a version number of this License, you may choose any version ever published by the Free Software Foundation.

10. If you wish to incorporate parts of the Program into other free programs whose distribution conditions are different, write to the author to ask for permission. For software which is copyrighted by the Free Software Foundation, write to the Free Software Foundation; we sometimes make exceptions for this. Our decision will be guided by the two goals of preserving the free status of all derivatives of our free software and of promoting the sharing and reuse of software generally.

#### NO WARRANTY

11. BECAUSE THE PROGRAM IS LICENSED FREE OF CHARGE, THERE IS NO WARRANTY FOR THE PROGRAM, TO THE EXTENT PERMITTED BY APPLICABLE LAW. EXCEPT WHEN OTHERWISE STATED IN WRITING THE COPYRIGHT HOLDERS AND/OR OTHER PARTIES PROVIDE THE PROGRAM “AS IS” WITHOUT WARRANTY OF ANY KIND, EITHER EXPRESSED OR IMPLIED, INCLUDING, BUT NOT LIMITED TO, THE IMPLIED WARRANTIES OF MERCHANTABILITY AND FITNESS FOR A PARTICULAR PURPOSE. THE ENTIRE RISK AS TO THE QUALITY AND PERFORMANCE OF THE PROGRAM IS WITH YOU. SHOULD THE PROGRAM PROVE DEFECTIVE, YOU ASSUME THE COST OF ALL NECESSARY SERVICING, REPAIR OR CORRECTION.

12. IN NO EVENT UNLESS REQUIRED BY APPLICABLE LAW OR AGREED TO IN WRITING WILL ANY COPYRIGHT HOLDER, OR ANY OTHER PARTY WHO MAY MODIFY AND/OR REDISTRIBUTE THE PROGRAM AS PERMITTED ABOVE, BE LIABLE TO YOU FOR DAMAGES, INCLUDING ANY GENERAL, SPECIAL, INCIDENTAL OR CONSEQUENTIAL DAMAGES ARISING OUT OF THE USE OR INABILITY TO USE THE PROGRAM (INCLUDING BUT NOT LIMITED TO LOSS OF DATA OR DATA BEING RENDERED INACCURATE OR LOSSES SUSTAINED BY YOU OR THIRD PARTIES OR A FAILURE OF THE PROGRAM TO OPERATE WITH ANY OTHER PROGRAMS), EVEN IF SUCH HOLDER OR OTHER PARTY HAS BEEN ADVISED OF THE POSSIBILITY OF SUCH DAMAGES.

#### END OF TERMS AND CONDITIONS

How to Apply These Terms to Your New Programs If you develop a new program, and you want it to be of the greatest possible use to the public, the best way to achieve this is to make it free software which everyone can redistribute and change under these terms.

To do so, attach the following notices to the program. It is safest to attach them to the start of each source file to most effectively convey the exclusion of warranty; and each file should have at least the “copyright” line and a pointer to where the full notice is found.

[one line to give the program's name and an idea of what it does.]

Copyright (C) [yyyy] [name of author]

This program is free software; you can redistribute it and/or modify it under the terms of the GNU General Public License as published by the Free Software Foundation; either version 2 of the License, or (at your option) any later version.

This program is distributed in the hope that it will be useful, but WITHOUT ANY WARRANTY; without even the implied warranty of MERCHANTABILITY or FITNESS FOR A PARTICULAR PURPOSE. See the GNU General Public License for more details.

You should have received a copy of the GNU General Public License along with this program; if not, write to the Free Software Foundation, Inc., 51 Franklin Street, Fifth Floor, Boston, MA 02110-1301, USA.



Also add information on how to contact you by electronic and paper mail.

If the program is interactive, make it output a short notice like this when it starts in an interactive mode:

Gnomovision version 69, Copyright (C) [year]  
[name of author]

Gnomovision comes with ABSOLUTELY NO WARRANTY;  
for details type 'show w'. This is free software, and you are welcome to redistribute it under certain  
conditions; type 'show c' for details.

The hypothetical commands 'show w' and 'show c' should show the appropriate parts of the General  
Public License. Of course, the commands you use may be called something other than 'show w'  
and 'show c'; they could even be mouse-clicks or menu items—whatever suits your program.

You should also get your employer (if you work as a programmer) or your school, if any, to sign a  
“copyright disclaimer” for the program, if necessary. Here is a sample; alter the names:

Yoyodyne, Inc., hereby disclaims all copyright  
interest in the program 'Gnomovision' (which  
makes passes at compilers) written by James  
Hacker.

[signature of Ty Coon], 1 April 1989  
Ty Coon, President of Vice

This General Public License does not permit incorporating your program into proprietary programs. If  
your program is a subroutine library, you may consider it more useful to permit linking proprietary  
applications with the library. If this is what you want to do, use the GNU Lesser General Public License  
instead of this License.

Copyright notice above.

51 Franklin Street, Fifth Floor, Boston, MA 02110, USA  
Verbatim copying and distribution of this entire article is permitted in  
any medium without royalty provided this notice is preserved.

**Hinweise**

Wir weisen darauf hin, dass derart gekennzeichnete Elektro- und Elektronikgeräte sowie Batterien, nicht über den Hausmüll, sondern getrennt bzw. separat gesammelt werden müssen. Bitte erkundigen Sie sich bei der zuständigen Stelle in Ihrer Stadt/Gemeinde nach Sammelstellen für Batterien und Elektromüll.



Hiermit erklärt die SANTEC BW AG, dass das vorliegende Gerät der Richtlinie 2014/35/EU Niederspannungsrichtlinie, 2014/53/EU (EMC), 2011/65/EU (RoHS).

Der vollständige Text der EU-Konformitätserklärung ist unter der folgenden Internetadresse abrufbar: [www.burg.biz](http://www.burg.biz) Bei technischen Fragen zum Produkt lesen Sie bitte die ausführliche Bedienungsanleitung und beachten Sie die FAQ, die Sie auf folgender Webseite finden: [www.burg.biz](http://www.burg.biz). Sollten Sie dennoch Fragen haben, wenden Sie sich bitte per E-Mail an: [camera-service@burg.biz](mailto:camera-service@burg.biz)

**Impressum**

Das Copyright dieser Bedienungsanleitung liegt ausschließlich bei der SANTEC BW AG. Jegliche Vervielfältigung auch auf elektronischen Datenträgern bedarf der schriftlichen Genehmigung der SANTEC BW AG. Der Nachdruck – auch auszugsweise – ist verboten. Alle genannten Firmen- und Produktnamen sind Warenzeichen oder eingetragene Warenzeichen bzw. Marken der jeweiligen Inhaber. Irrtum und technische Änderungen vorbehalten.

Irrtum und technische Änderungen vorbehalten.

© Copyright: SANTEC BW AG  
Wormgermühle  
58540 Meinerzhagen, Germany

**Notes**

Please be aware that electrical and electronic equipment and batteries shall not be disposed of as household waste, but rather collected separately. Please obtain information on the collecting points for electrical waste from the responsible authority of your municipality.



SANTEC BW KG hereby declares that this device complies with Directive 2014/35/EU Low Voltage, 2014/53/EU, (RED) 2014/30/EU, (EMC), 2011/65/EU (RoHS). The full text of the EU Declaration of Conformity can be found on [www.burg.biz](http://www.burg.biz). If you have technical questions about this device, please read the detailed user manual and the FAQ sheet which you will find on the following website: [www.burg.biz](http://www.burg.biz). If, however, you still have questions, please send an e-mail to: [camera-service@burg.biz](mailto:camera-service@burg.biz)

**Copyright**

All rights reserved. This publication may not be reproduced, stored in a retrieval system or transmitted, in any form or by any means (electronic, mechanical, photocopying, recording or otherwise), without the written prior permission of SANTEC BW AG. No reproduction of any part or excerpts thereof are permitted. Errors excepted. Specifications are subject to change without notice for quality improvement. All companies or products mentioned in this publication are trademarks, registered trademarks or brands of the respective company. Subject to technical changes without notice. Errors excepted. Specifications are subject to change without notice for quality improvement.

