

2

1

SQUEEZETOPS

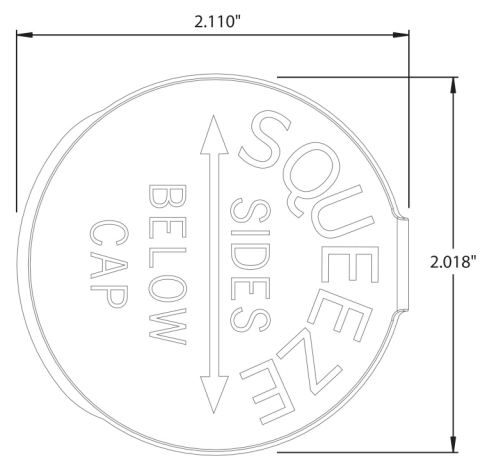

PST-60

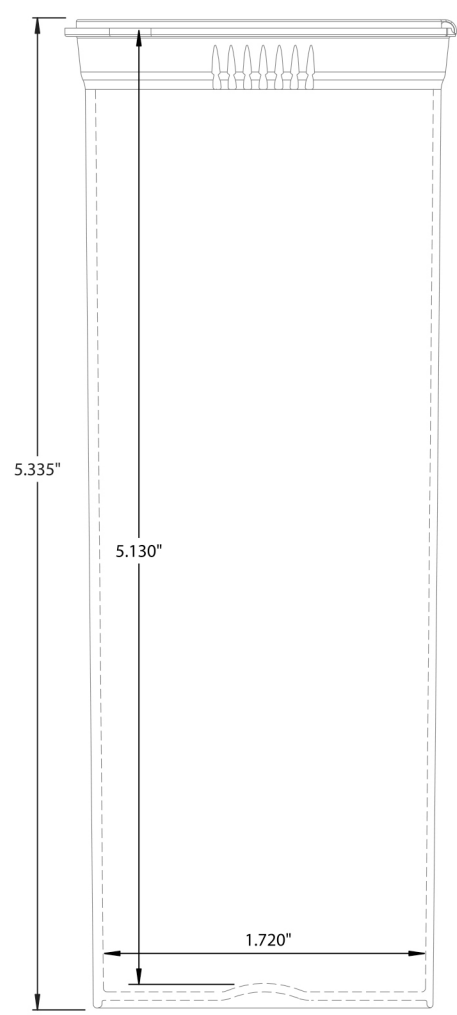

NOTE: All dimensions +/-0.030" unless otherwise noted.

B

B

A

A

PROPRIETARY AND CONFIDENTIAL
 THE INFORMATION CONTAINED IN
 THIS DRAWING IS THE SOLE
 PROPERTY OF ██████████
 ANY REPRODUCTION IN PART OR AS
 A WHOLE WITHOUT THE WRITTEN
 PERMISSION OF ██████████
 IS PROHIBITED.

NEXT ASSY	USED ON	
APPLICATION		

DIMENSIONS ARE IN INCHES
 TOLERANCES:
 FRACTIONAL ±
 ANGULAR: MACH ± BEND ±
 TWO PLACE DECIMAL ±
 THREE PLACE DECIMAL ±

MATERIAL
 Clear Medical Grade PP
 Flint Hills 13T25A or Equivalent

FINISH

DO NOT SCALE DRAWING

	NAME	DATE
DRAWN	Frank Turcaz	2/21/2019
CHECKED		
ENG APPR.		
MFG APPR.		
Q.A.		
COMMENTS:		

SQUEEZETOPS PST-60 Part Specification Drawing		
SCALE:1:1	WEIGHT:	SHEET 1 OF 1

2

1