

OPERATION & SAFETY MANUAL



WARNING

*These instructions are for your personal safety. Always ensure that you have read and understood these instructions before using the machinery. **SAVE THESE INSTRUCTIONS FOR FUTURE REFERENCE.***

TABLE OF CONTENTS

TOPIC	PAGE
Safety Information	3
Environmental, Transport, Storage & Disposal	5
General Information	6
Technical Data	7
Intended Use	7
Available Tooling	7
Packages	8
Voltage & Power Supply	9
Safety Features	9
Noise Levels, Vibrations & Emissions	10
CE Declaration of Conformity	11
Operating Instructions	12
Starting & Using the Machine	12
Rotation Speed Dial & Tightening Set Screws	13
Navigating Through Knuckle Bends	14
Navigating Through P-Traps	15
Maintenance Program	16
Warranty Periods	16
Maintenance	17
Replacing Carbon Brushes	17
Replacing Safety Clutch Spring	20
Inspecting the Shaft for Damage	21
Servicing the Flexible Shaft & its Outer Casing	22
Changing the Flexible & Shaft Flexible Shaft Extension	22
Accessories & Spare Parts	23
Practical Tips & Safety Advice	25
Picote MINI CLEANER +C 8/16	27
+C Operating Instructions	28
+C Technical Data	30
+C Spare Parts	31
Troubleshooting Flowchart	32
Warranty Policy & Procedure	33

To watch practical demonstration videos, take a course, or to download an electronic copy of these Instructions, please visit www.picoteinstitute.com. Please note that videos and courses are not intended as a replacement or alternative to this operating and safety manual, but only as an additional learning tool.

SAFETY INFORMATION

SAVE ALL WARNINGS AND INSTRUCTIONS FOR FUTURE REFERENCE

WARNING

This section contains important safety information. Failure to comply could result in serious injury.

Safety Symbols

Safety symbols are used throughout this manual to draw attention to potential hazards.



Danger risk of serious injury or death by electrocution, follow instructions.



Danger risk of serious injury, follow instructions.



Danger risk of serious injury from rotating parts, follow instructions.



Danger risk of serious injury from hot parts, follow instructions.



Danger do not touch. Risk of injury, follow instructions.

Personal Protective Equipment (PPE)

Always use Personal Protective Equipment including suitable protective clothing, footwear plus:



Suitable eye protection to protect against sewage, chemicals or dust from irritating eyes.



Suitable ear protection to protect against hearing loss.



Suitable heat and cut-resistant gloves to help prevent any hand injuries. Any open injuries or skin irritations should always be covered to avoid contact with sewage, chemicals or dust.



Suitable respirator to prevent any dust or fumes being inhaled or consumed, which could cause occupational asthma or dermatitis.

GENERAL MACHINE SAFETY INFORMATION

SAVE ALL WARNINGS AND INSTRUCTIONS FOR FUTURE REFERENCE

WARNING



This section contains important safety information. Failure to comply could result in serious injury or death.

Always read all safety warnings and instructions. Failure to follow warnings and instructions may result in electric shock, fire and/or serious injury.



1. **Always wear eye and ear protection as well as heat and cut-resistant gloves.**

Other personal protective equipment, such as dust mask, gloves and overalls should be worn when necessary. Dust produced when working can be dangerous to your health, inflammable or explosive. **Always wear appropriate personal protective equipment.**

2. Make sure the pipe has been opened and ventilated to prevent any gases accumulating.
3. Always ensure that the machine is fully turned off and unplugged before inspection, maintenance, or installing any accessories to the machine. Always follow the instructions in the manufacturer's manual.
4. Before each use inspect the machine carefully for any potential break or damage. **Change damaged parts immediately.** It is especially important to check the end of the flexible power shaft for any signs of wear and tear, and repeat the process for the outer casing.
5. When in use, it is very important that the machine is stable and on an even surface at all times.
6. **Never leave the machine running unattended.** Always hold the flexible shaft with both hands firmly when operating the machine.
-  7. **Do not touch the Cutter or Grinding Chains immediately after use;** they may be hot and could burn your skin
8. If the working environment is extremely hot and humid, or badly polluted by conductive dust, use a GFCI-enabled power outlet to ensure the safety of the operator.
9. Make sure that the job location is well ventilated before grinding or drilling. Always use a vacuum extraction system in the pipe to remove dust. The operator must wear a dust mask when using dry grinding to clean pipes.
10. Ensure that the ventilation openings are kept clear when working in dusty conditions. If it should become necessary to clear dust, first unplug the machine. Avoid damaging internal parts.
-  11. **Do not use the machine on any materials containing asbestos.**
12. **Never touch rotating parts.** Do not stand on the machine.
13. Only use this machine with the accessories and spare parts offered by Picote Solutions. Accessories and spare parts should only be used in the pipe intended and as described by Picote Solutions.
14. Only operate the foot pedal or OPC as instructed. Never place anything on it in place of a foot.
15. **Do not use the Mini Cleaner or Mini Cleaner +C with an extension.**

SAVE ALL WARNINGS AND INSTRUCTIONS FOR FUTURE REFERENCE

⚠ WARNING *This section contains important safety information. Failure to comply could result in serious injury or death*

ENVIRONMENTAL

Operational Ambient Temperature Range:	-10°C to 50 °C or 14°F to 122°F frost and condensation free
Storage Ambient Temperature Range:	-20°C to 60 °C or -4°F to 140 °F frost and condensation free
Maximum Altitude:	2000m or 6500 ft. Derate above 1000m or 3280ft: 1% / 100m or 328ft
Maximum Humidity:	95% non-condensing
Camera Maximum Humidity:	90% non-condensing

TRANSPORT

The Mini Cleaner +C should be transported in a car or other vehicle and laid down and secured with ratchet straps to prevent any sudden movements or accidents caused by hard braking or an accident.

Never transport the machine with a tool attached to the shaft. Always retract the camera back to its housing during transport.

If using a pick-up or trailer to transport Picote Millers always suitably cover the unit to protect it from the elements.

STORAGE

It is recommended that Picote Millers be stored indoors to protect them from rain and sunlight, and also in a constant ambient temperature. The best way to store the machines is using the same box that the machine has been shipped in.

If the Mini Cleaner or Mini Cleaner +C has been stored in an environment colder than +10 °C or 50 °F, the machine should be stood at room temperature for 24 hours before use.

If the Mini Cleaner or Mini Cleaner +C has been stored for long periods of time (over 2-3 months), it should be checked and tested according to the maintenance programme before use.

Charge the DVR battery fully before storing for long periods. **Do not leave the DVR unit unattended while it is charging.**

DISPOSAL

The Mini Cleaner motor, control box, electric wires, axle package including slip ring, camera monitoring box, power supply and camera head can be disposed in Europe at Waste Electrical and Electronic Equipment (WEEE) collection points.

The Miller frame, reel, flexible shaft, camera cable reel and name plate can be recycled in metal waste collection points.

The outer casing of the shaft and the camera plastic supports can be disposed of as plastic waste.

Always follow the local waste handling rules and regulations.



Li-ion

The +C camera monitoring box includes a Li-ion battery.

GENERAL INFORMATION

SAVE ALL WARNINGS AND INSTRUCTIONS FOR FUTURE REFERENCE

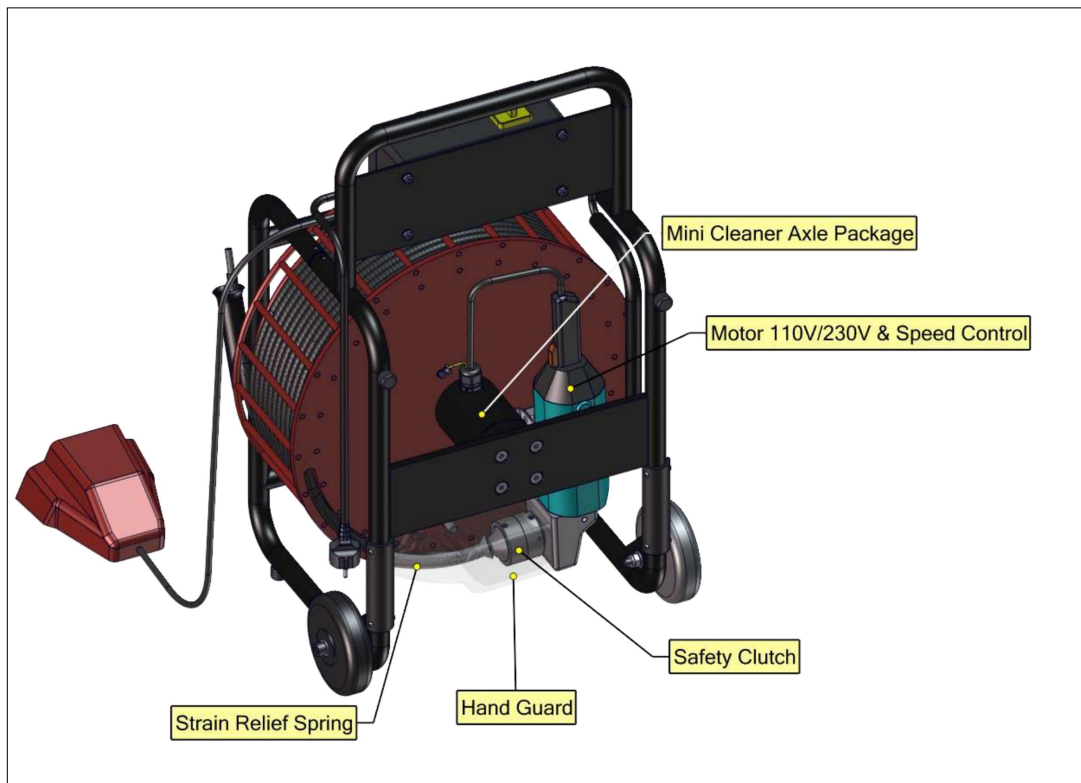

CAUTION When in use always lay the machine down horizontally on the floor. When not in use some non-hazardous Picote Flexible Shaft Lubricant might leak from the hand guard.

TECHNICAL DATA

SAVE ALL WARNINGS AND INSTRUCTIONS FOR FUTURE REFERENCE

Size (mm/inches)	Shaft (mm/ inches)	Range (m/ft)	Recommended Pipe Diameters (mm/inches)	Rotating Speed (rpm)	Output (W)	Power Source	Weight (kg/lbs)
740x519x404 29"x20"x16"	8 / 1/3"	16 / 50	DN32-DN75 / 1¼"-3" DN100 / 4" only for cleaning through non- symphonic toilet (in some regions)	500-2900*	110V:1100 230V:1200	Electric Motor	26.5 / 59
				*Optimal rotation speed 900-2100 rpm (speed dial 2-4). Check page 13 for further information.			

INTENDED USE

This machine is intended for the following uses;

1. Cleaning and unblocking pipes and drains by grinding.
2. Descaling pipes.
3. Opening lateral connections.
4. Picote Brush Coating™ with the Mini Coating Pump.

AVAILABLE TOOLING

Always follow the Picote Solutions instructions when installing and using the machine with accessories.

Cleaning Chain	Cyclone Chains	Original Chains
Smart Cutter™	Smart Cutter™ - with Cleaning Panels	Mini Sweeper
3D Chains	Twister Mini Flexi	Special Drill Head
Coating Brushes	Cleaning Brushes	Smart Cleaner

Please check Picote Solutions Quick Cleaning Guides and Tool Manuals for more detailed information:

www.picoteinstitute.com

The Mini Cleaner and Mini Cleaner +C come complete with Tool Packages depending on region:

North America (NA) : Mini Cleaner Cleaning Package or Mini Cleaner Cutting Package

Rest of World (ROW) : Mini Cleaner Tool Kit for use on DN32-DN40 or 1¼"-1½" pipes

PACKAGES INCLUDED

SAVE ALL WARNINGS AND INSTRUCTIONS FOR FUTURE REFERENCE

INCLUDED TOOLS IN MINI CLEANER PACKAGE (ROW)

3540000816TK	Mini Cleaner Tool Kit (ROW)
1000818025	Hub 8.5x18x25 (DN32-40)
1381084032	Cleaning Chain DN32
1381084040	Cleaning Chain DN40
2125000032CL	Cleaning Brush DN32
2125000040CL	Cleaning Brush DN40
1240035045	Cleaning Panel DN32 35x45 (10 pcs)
1240040050	Cleaning Panel DN40 40x50 (10 pcs)

INCLUDED TOOLS IN MINI CLEANER CUTTING PACKAGE (NA)

3540000818CU	Mini Cleaner Cutting Package (NA)
1360080051	Smart Sweeper Head DN40-DN50 (1½"-2")
1000818025	Smart Cleaner Hub 8.5x18x25 DN32-DN40 (1¼"-1½")
1201030050	Side Grinding Panel 30x50 DN40 (1½") Package
1230000054	Twister Mini Flexi DN50 (2")

INCLUDED TOOLS IN MINI CLEANER CLEANING PACKAGE (NA)

3540000818CL	Mini Cleaner Cleaning Package (NA)
1360080051	Smart Sweeper Head DN40-DN50 (1½"-2")
1000818025	Smart Cleaner Hub 8.5x18x25 DN32-DN40 (1¼"-1½")
1201030050	Side Grinding Panel 30x50 DN40 (1½") Package
1381084040	Cleaning Chain DN40 (1½")
1300212025	Front Drill Head 25mm for DN50 (2") pipes

Check out the overall list of the available tools and spare parts from page 23-24.

SAVE ALL WARNINGS AND INSTRUCTIONS FOR FUTURE REFERENCE

Ensure that the supply voltage is correct. The voltage of the power source must match the value given on the nameplate of the machine within the tolerances of $\pm 10\%$. Machines with a 230V plate can be used in 220V mains and 110V machines in the 120V grid.

The machine has been double sealed according to European standards. The power source has to be grounded.

Camera power supply can operate with Input: 110VAC ~ 240 VAC, Output: 12V DC 1200mA. The DVR unit has in-built 5200 mAh Li-ion battery (7.4 V).

Power Plugs

For safety purposes only use grounded outlets. If the plug does not fit securely or match the outlet **do not force it** — contact an electrician to determine required power supply. Never alter the plug in any way. Use the plug with an extension cord only if it can be fully inserted into the receptacle. Use the Mini Cleaner or Mini Cleaner +C with a heavy duty extension cord only.

If a power generator is used as power source ensure that the power rating is sufficient.

220-230V: EU Schuko 230 V 16 A. Power cable lead minimum thickness 1.5mm^2 .

110-125V: The Mini Cleaner and Mini Cleaner +C is equipped with a 16 amp (125V) NEMA 16 amp plug. Power cable lead minimum thickness $2.5\text{mm}^2 / 14\text{AWG}$. The Mini Cleaner and Mini Cleaner +C must be supplied with sufficient power and proper current rating. A minimum of 15 amps are needed to operate it safely and efficiently. When used with an extension cord, the cord must be a 3 prong, 16 amp (125 V). If power generator is used, minimum 3 kW required. Adapters may be necessary for generator connections. Contact your Reseller or Picote technical support for more information.

AUSTRALIA/UK: Mini Cleaners & Mini Cleaners +C in these regions have special plugs.

Australia: CEE 16 A 230 V colour blue. Power cable minimum lead thickness 2.5mm^2 .

UK: UK Plug BSEN 60309 16 A 110 V colour yellow. Power cable lead minimum thickness 2.5mm^2 .

The Mini Cleaner and Mini Cleaner +C requires a transformer to comply with the site power regulations and safe usage in UK.

NOTE: If working with a generator always use the 110 V transformer. Do not plug directly in to the generator.

SAFETY FEATURES



The machine is equipped with an Emergency Switch Off Button. The power supply to the motor is cut off when the Emergency Switch Off Button is pushed. Always make sure the Emergency Switch Off Button is pressed or completely unplug the machine when the machine accessories (e.g. Cutter or Grinding Chains) are not inside a pipe. Always unplug the machine from the power source when performing any maintenance or repairs to the machine.

The machine is operated by foot pedal (Operator Presence Control or 'OPC'). When the control is not held down the machine stops. Never place any kind of object on the pedal in place of a foot (such as a brick).

NOISE LEVELS, VIBRATIONS & EMISSIONS

SAVE ALL WARNINGS AND INSTRUCTIONS FOR FUTURE REFERENCE



This section contains important safety information. Failure to comply could result in serious injury or loss of hearing.

The typical A-weighted noise level determined according to **EN60745**:



WEAR EAR PROTECTION

Sound pressure level (LpA): 90 dB (A)

Sound power level (LWA): 103 dB (A)

Emissions during actual use of the machine can differ from declared values depending on the ways that the machine is used. Safety measures to protect the operator should be determined by actual conditions, taking into account all aspects of the operating cycle (such as when the machine is switched off and when it is running idle).

Due to continuing product development the specifications herein are subject to change without notice!

VIBRATION

Hand vibration levels depend on the distance from the tool head to the user and working conditions. The vibration levels detailed below have been measured at the Picote training facilities in Finland. Vibration has been determined according to ISO-5349 and EU-directive 2002/44/EG.

Safe daily exposure time for user:

Exposure Action Value (EAV) 2,5 m/s²

Exposure Limit Value (ELV) 5,0 m/s²

Tooling	Working Distance m/ft	EAV	ELV
Original Cleaning Chain DN32 / 1¼"	0-2m / 0-6.6ft	50min	3h 18min
Original Cleaning Chain DN32 / 1¼"	5-7m / 16-23ft	9h 37min	Over 24h
Original Cleaning Chain DN50 / 2"	0-2m / 0-6.6ft	7h 13min	Over 24h
Original Cleaning Chain DN50 / 2"	5-7m / 16-23ft	Over 24h	Over 24h
Mini Smart Sweeper DN50 / 2"	0-2m / 0-6.6ft	Over 24h	Over 24h
Mini Smart Sweeper DN50 / 2"	5-7m / 16-23ft	17min	1h 8min
Special Drill Head DN50 / 2"	0-2m / 0-6.6ft	5h 27min	21h 48min
Special Drill Head DN50 / 2"	5-7m / 16-23ft	Over 24h	Over 24h
Twister Mini Flexi DN50 / 2"	5m / 16ft	6h 9min	Over 24h
Smart Cutter™ DN50 / 2"	5m / 16ft	Over 24h	Over 24h
Cyclone Chain PVC DN100 / 4"	2m / 6.6ft	21h 58min	Over 24h
Cyclone Chain PVC DN100 / 4"	5-7m / 16-23ft	15h 43min	Over 24h

CE DECLARATION OF CONFORMITY

SAVE ALL WARNINGS AND INSTRUCTIONS FOR FUTURE REFERENCE

We Picote Solutions Oy Ltd as the responsible manufacturer declare that the following Picote Solutions Oy Ltd drain cleaning machines:

Mini Cleaner

Model No: 8/16

and

Mini Cleaner +C

Model No: 8/16

are of series production and

Conform to the following EU Directive:

2006/42/EY

And are manufactured in accordance with the following standards or standardised documents:

EN62841-1

EN62841-13

ISO-5349-1:2001

The technical documentation is kept by our authorised representative in Europe who is:

Picote Solutions Oy Ltd, Pienteollisuustie 24
06450 Porvoo, Finland

31st July 2020

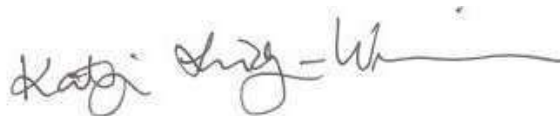

Katja Lindy-Wilkinson

C.E.O.

Picote Solutions Oy Ltd

Pienteollisuustie 24, 06450 Porvoo, Finland

OPERATING INSTRUCTIONS

SAVE ALL WARNINGS AND INSTRUCTIONS FOR FUTURE REFERENCE

Before operation:

WARNING



- Before installing Picote tools, always make sure that the machine is fully turned off and unplugged.

CAUTION



- Always round off the sharp edges of the shaft to avoid cuts and to make it easier to insert the shaft into the tool or leader to be used.

- Check that there is the correct length of flexible shaft (without its plastic casing) at the end of the flexible shaft and that all screws have been loosened so that the shaft can be easily inserted inside the tool. Position the shaft inside the tool, as far as it will go, and tighten the screws. **Consult accessory manuals (cutters & grinding chains) for detailed information.**

While in operation:

- Always lay the machine down horizontally on the floor. During drilling, grinding and cutting processes, always use a separate vacuum extraction system or run water in the drain to remove dust.

STARTING & USING THE MACHINE

WARNING

This section contains important safety information. Failure to comply could result in serious injury.

1. The machine has an operator presence control or 'OPC'. When the control is not held down, the machine stops. The machine can also be stopped by pushing the Emergency Stop Button down, rotating the power gear to "O" or unplugging the machine.
2. Check the rotational speed of the shaft before powering up. The control of the rotational speed is located in the motor. The rotational speed can be selected from 1 to 4.
3. Place the tool inside the pipe.
4. Turn on the power switch.
5. Release the Red Emergency Switch Off Button.
6. The machine starts when the OPC foot pedal is pressed down. Always hold the flexible shaft with both hands firmly while operating the machine.
7. Rotating the tool slowly makes it easier to move the tool forward inside the pipe.
8. The life span of the shaft outer casing can be prolonged by using a Sleeve Bearing designed for the outer casing.

There is a mechanical safety clutch installed in Mini Miller. If the machine is overloaded the safety clutch separates the shaft from the motor. User will hear a loud noise when this happens. Release the foot pedal, pull the shaft back a little bit and continue working. If the safety clutch is released constantly the silicone spring inside of it may have worn down. Look at the Safety Clutch— Spring Change instructions to change the spring. Brief changing instructions can be found also in this manual pages 20-21.

Avoid overloading the motor.

OPERATING INSTRUCTIONS

SAVE ALL WARNINGS AND INSTRUCTIONS FOR FUTURE REFERENCE

WARNING

This section contains important safety information. Failure to comply could result in serious injury.



The optimal rotation speed of the Mini Cleaner and Mini Cleaner +C is **between 2-4 (900-2100 rpm) depending on the work**. Minimum rotation speed is usually preferred when moving the tool around tight bends. When beginning work adjust the speed up to the level which seems to work the best.

Do not use a higher rotation speed than setting 4 (2100 rpm) as it may cause overheating between the shaft and the outer casing.

The speed dial can be found on the motor itself (see image right). Set the speed by rotating the button. Check the corresponding rotation speed from the table below.

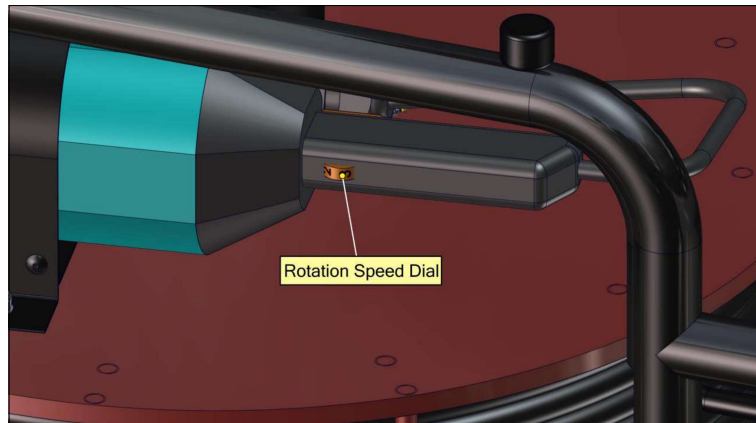

Rotation Speed	Speed dial					
3200						X
2700					X	
2100			X			
1500		X				
900	X					
600	X					
	1	2	3	4	5	6

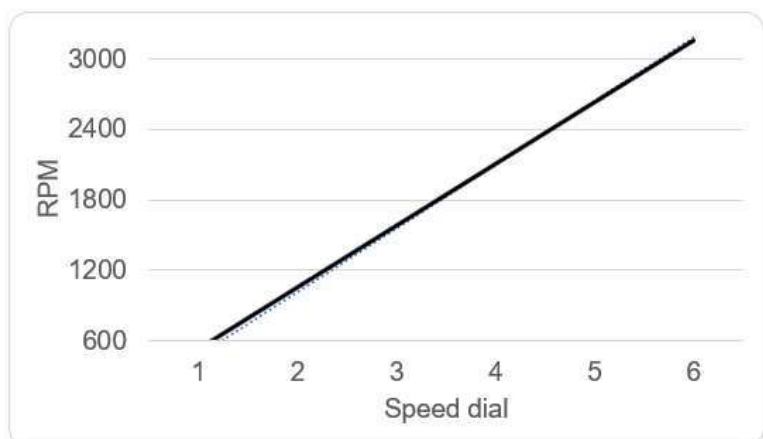

TIGHTENING THE SET SCREWS

When you add a tool always tighten the screws starting from the screw furthest away from the end of the flexible shaft (where applicable).



NAVIGATING DN32-DN50 / 1¼" -2" KNUCKLE BENDS

SAVE ALL WARNINGS AND INSTRUCTIONS FOR FUTURE REFERENCE

Step 1. Always keep the Mini Cleaner and Mini Cleaner +C as close as possible to the pipe where work takes place. This way only a small portion of the shaft is unsupported.

Step 2. Place the tool completely inside the pipe before powering up. Rotating the tool slowly makes it easier to move the tool through tight bends.

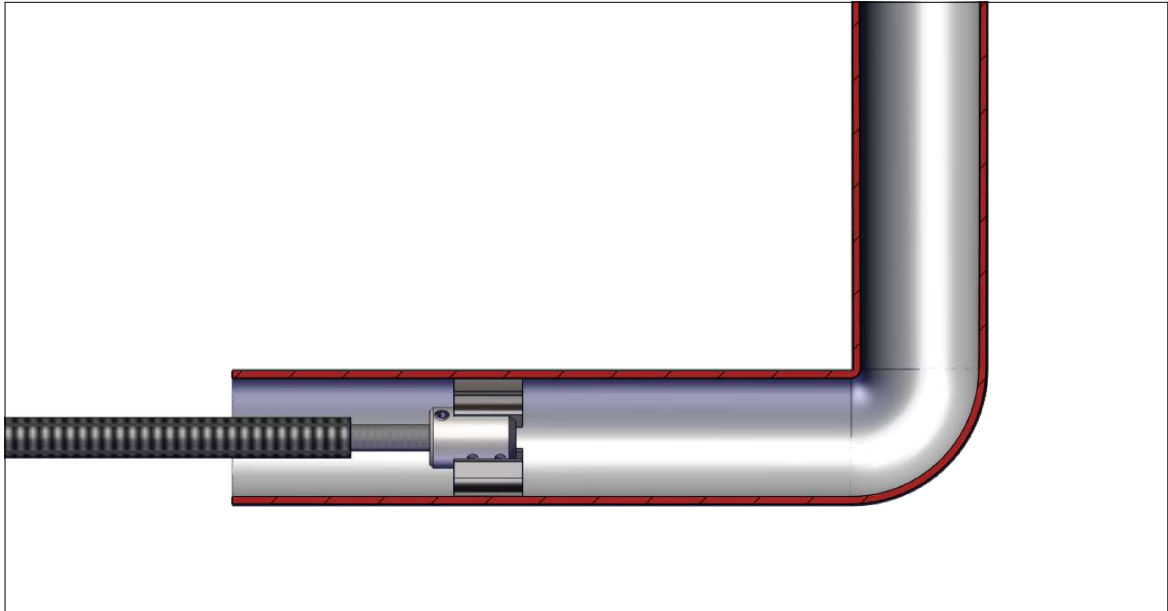

Step 3. Push and rotate at the same time at a low speed. The shaft is flexible enough to navigate through several 90° bends. Move the tool constantly back and forth in the pipe. The special spring outer casing in the Mini Cleaner and Mini Cleaner +C can melt because of the friction heat created if the tooling is kept in the same place for long periods of time.



NAVIGATING THROUGH DN50/2" P-TRAPS

SAVE ALL WARNINGS AND INSTRUCTIONS FOR FUTURE REFERENCE

Step 1. Place the tool completely inside the pipe before powering up. Rotating the tool slowly makes it easier to navigate through tight bends.

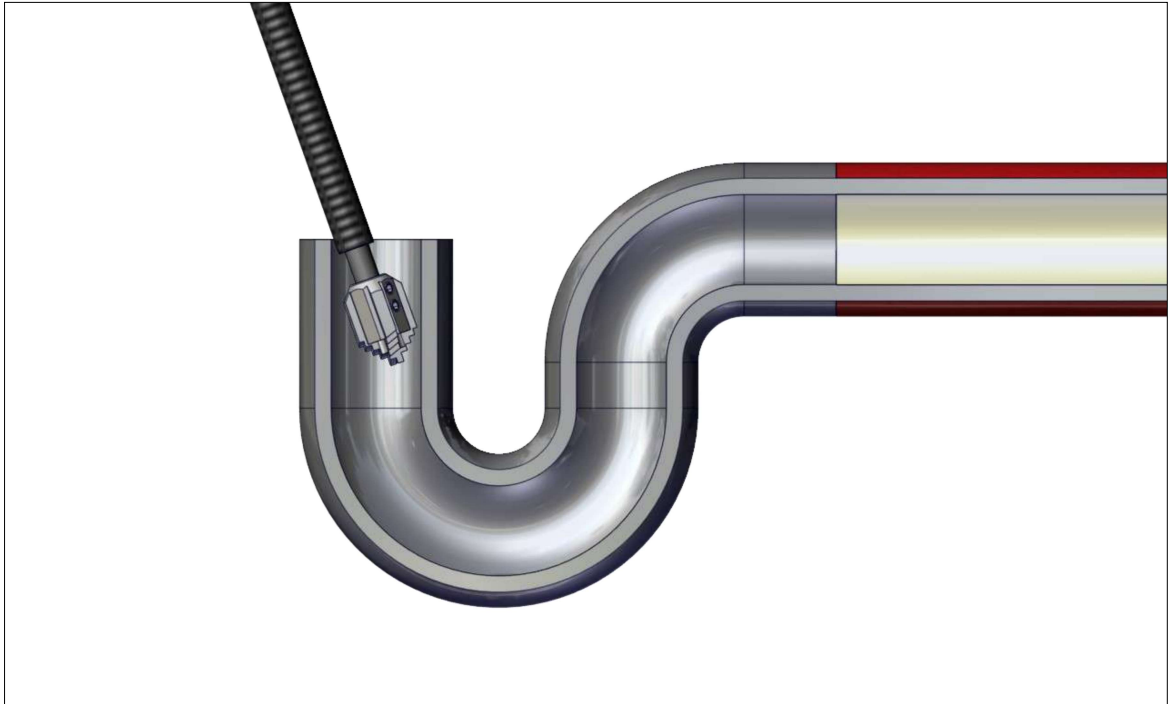

Step 2. Move tool constantly back and forth in the pipe. The special spring outer casing in the Mini Cleaner/ Mini Cleaner +C can melt because of friction heat created by tooling being kept in the same place over long periods of time.

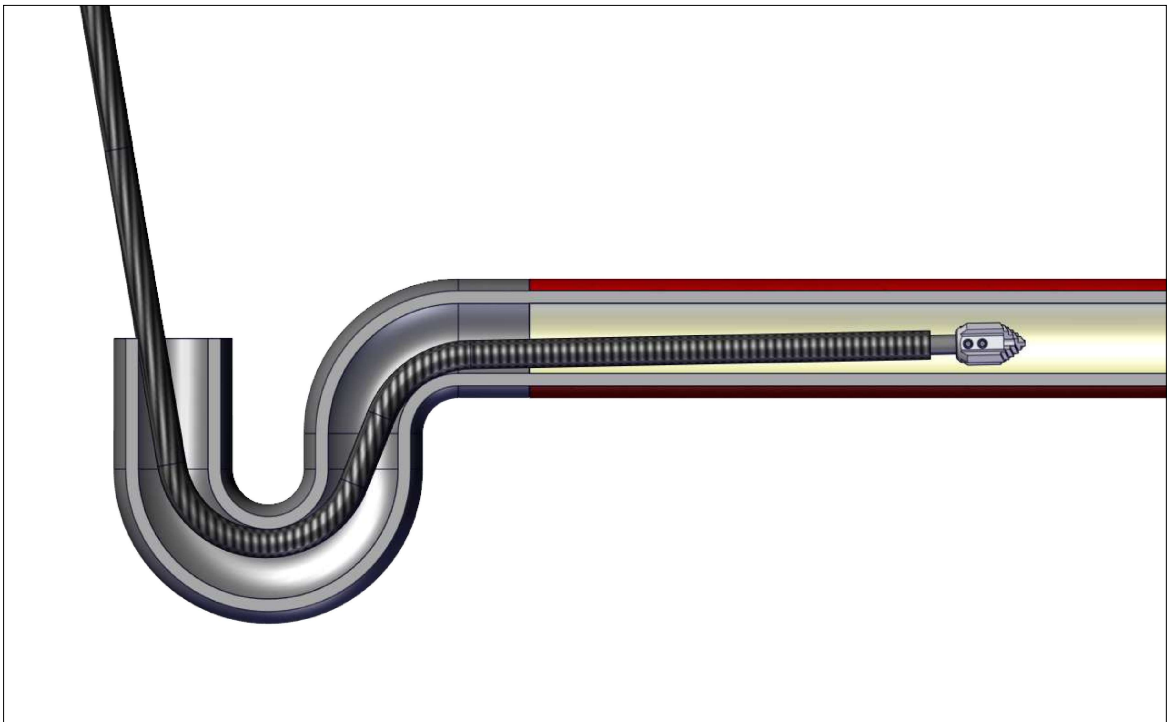

MAINTENANCE PROGRAMME & WARRANTY PERIODS

SAVE ALL WARNINGS AND INSTRUCTIONS FOR FUTURE REFERENCE

Maintenance task	Months			
	3	6	12	24
Change motor carbon brushes			I	R
Tightness of motor fixing			I	I
Alignment of motor			I	I
Condition of frame			I	I
Condition of wheels & rubber bushes			I	I
Condition of control box			I	I
Condition of electric cables	I	I	I	I
Condition of electrical connections	I	I	I	I
Lubricate Shaft	P	P	P	P
Operation of E-Stop	I	I	I	I
Safety Clutch Silicone Ring	I	I	I	I
Operation of Safety Clutch	I	I	I	I

I: Inspect, fix or replace if needed.

P: Perform, replace if needed.

R: Replace

WARRANTY PERIODS

Picote Solutions grants limited warranty for certain machines, equipment & components. Read more detailed information on page 33 (Picote Warranty Policy and Procedure).

Service Period	3 months	6 months	1 year
A			
B			
C			

A Milling machine & spare parts, except;

B Electric motors

C Service Centre repair work



1. Before performing any maintenance always check that the machine is fully turned off and unplugged.
2. Always inspect the flexible shaft before each use. If there are potential weak points, or the shaft is damaged, cut off the damaged length using a band saw or replace the entire shaft as needed.
3. For safety and efficiency, always keep the machine and its motor, drive unit, ventilation and cooling slots clean.
4. Remove the hand guard and check that the screws for the shaft socket are securely tightened (weekly).
5. Check that all the bolts and screws on the machine are securely tightened.
6. It is recommended that the oil in the bevel gear should be changed about every 12 months. Only use regular oil developed for gearboxes.

REPLACING CARBON BRUSHES

Remove and check carbon brushes regularly and replace when worn down to the limit mark. See page 16 for maintenance intervals. Keep the carbon brushes clean and free to slip in the holders. Both carbon brushes should be replaced at the same time. Use only identical carbon brushes.

The complete motor needs to be removed in order to change both of the carbon brushes. Follow the steps shown below.

Use a screwdriver to remove the brush holder caps. Take out the worn carbon brushes, insert the new ones and secure the brush holder caps.

Step 1. Open Allen bolts and remove the hand guard.

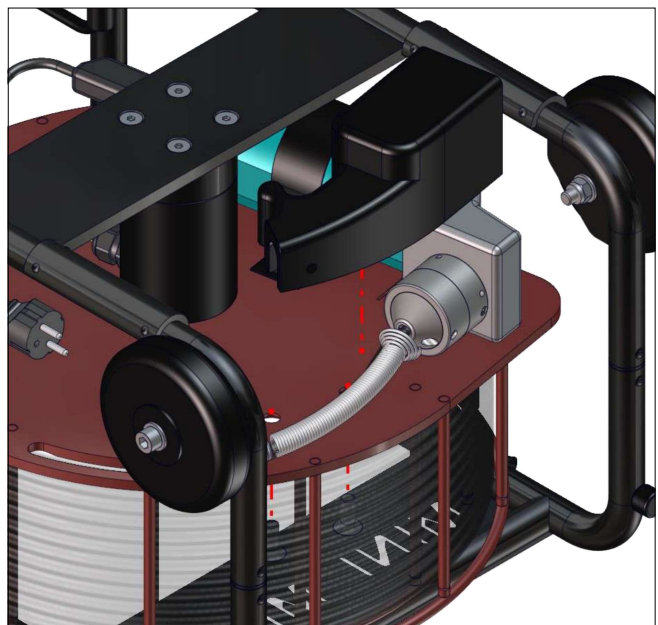

Step 2. Open Set Screws and detach the shaft from the Safety Clutch.

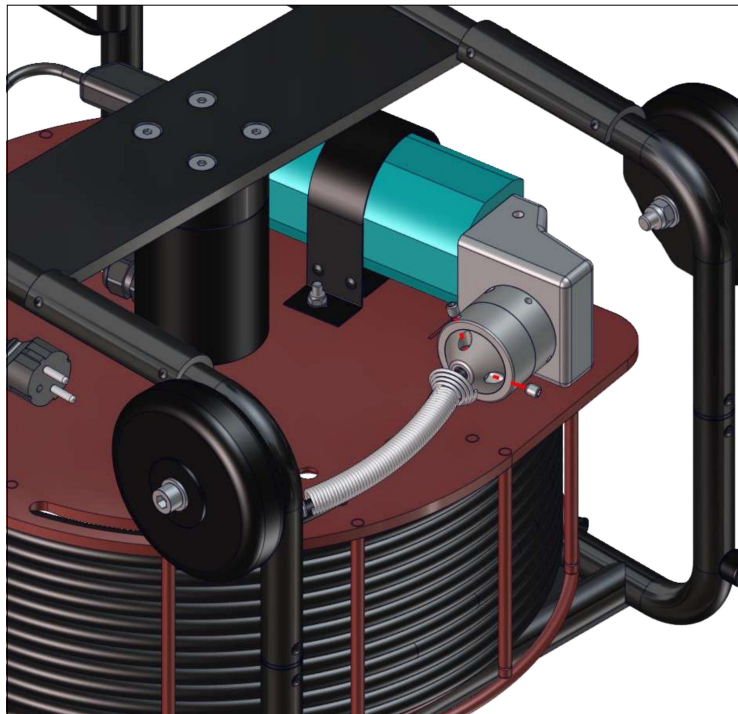

Step 3. Open the Allen Bolts which attach the motor to the reel.



SAVE ALL WARNINGS AND INSTRUCTIONS FOR FUTURE REFERENCE

Step 4. Open the protective caps with a screwdriver and replace both of the carbon brushes. Repeat the steps in opposite order to reassemble. Tighten the Hex Bolt M8x25 which is attaching the motor to the reel in torque of 12 Nm. **Recommended use of Loctite 542.**

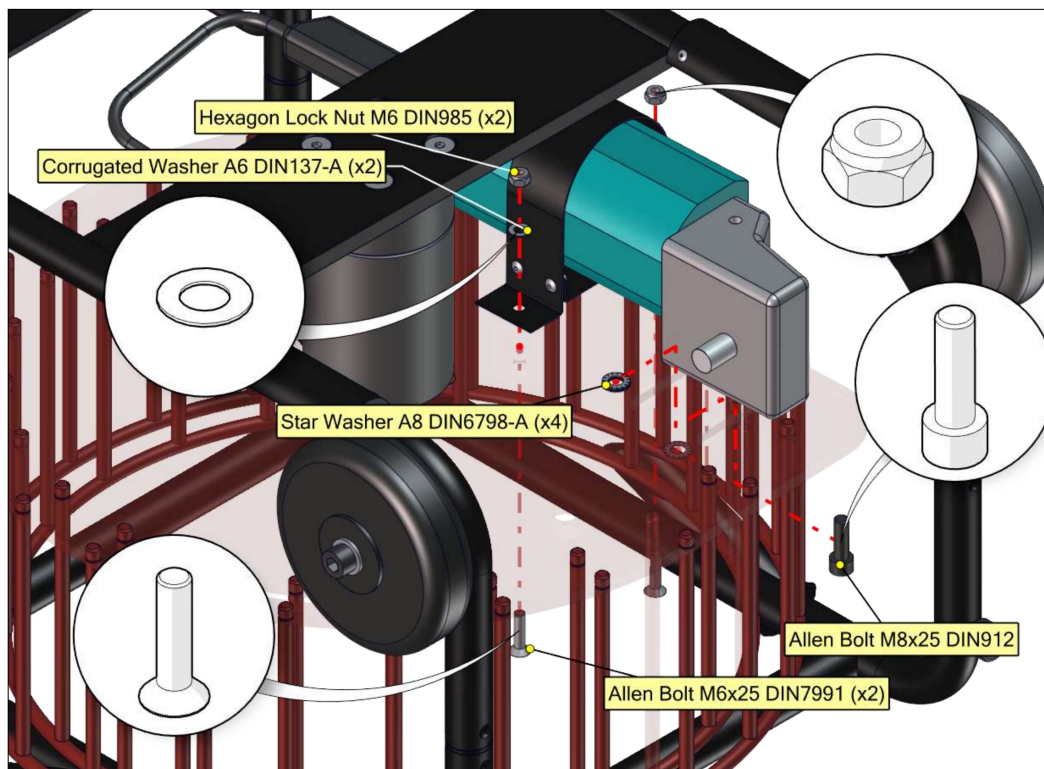
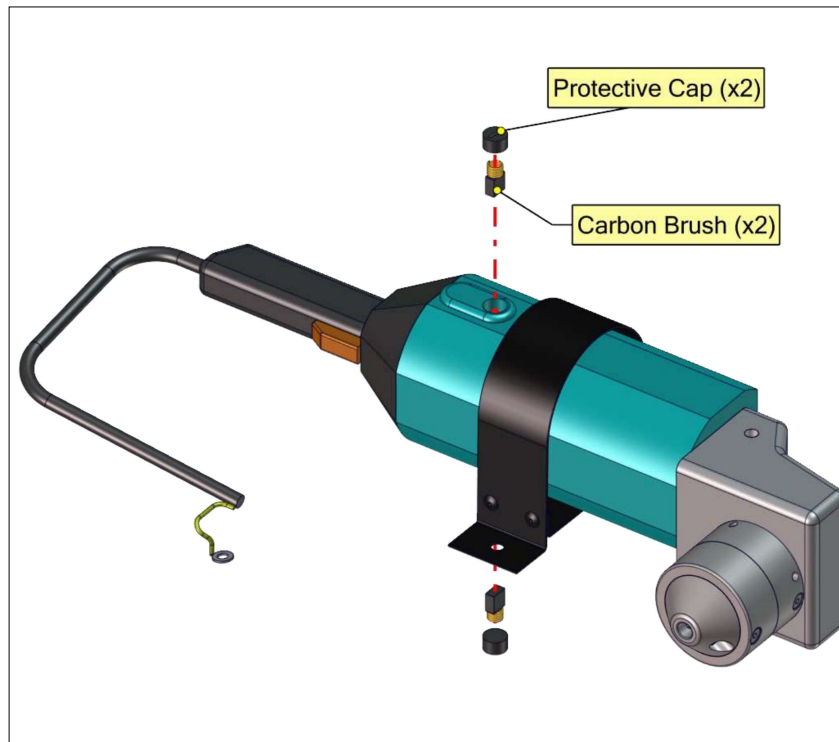

REPLACING SAFETY CLUTCH SPRING

Remove and check the silicone spring of the Safety Clutch regularly and replace when worn down. When safety clutch begins to release constantly the spring should be changed.

The silicone spring can be easily changed even in field conditions.

Step 1. Remove the hand guard and detach the flexible shaft from the Safety Clutch. Open and remove four screws from the Safety Clutch Covers.

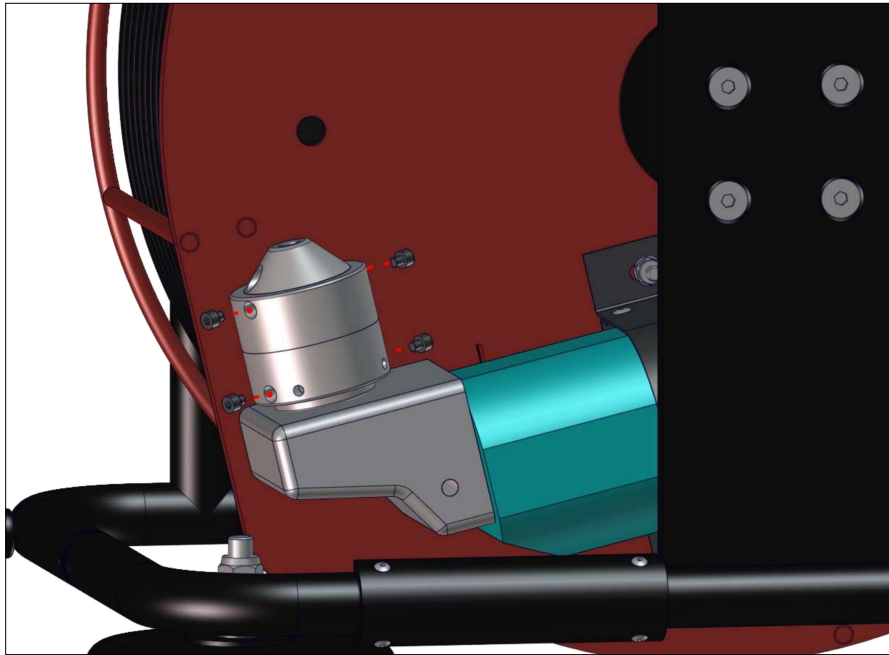

Step 2. Remove the Upper Cover and push the Lower Cover down.

NOTE: The silicone ring for the Mini Cleaner and Mini Cleaner +C is **RED**.

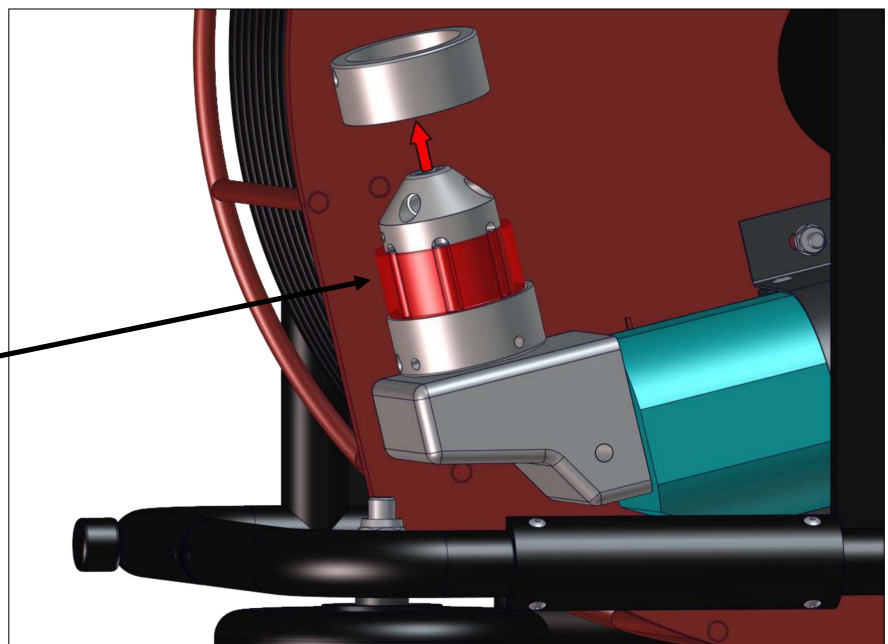

Step 3. Remove the old Silicone Spring and replace it with a new one. Be careful not to drop axles from the heart of the clutch. Repeat the steps in **reverse order**.

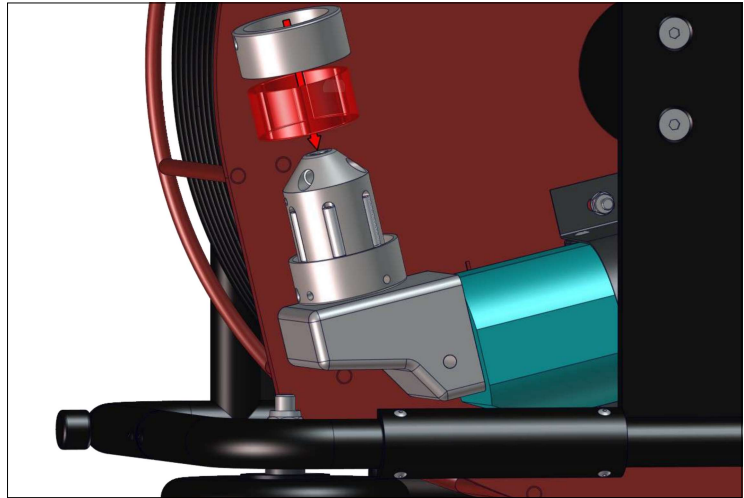

Step 4. The correct way to install shaft into the safety clutch is shown below. There should only be 3mm or 1/8" in-between the outer casing and safety clutch. Push the shaft all the way to the end of the safety clutch.

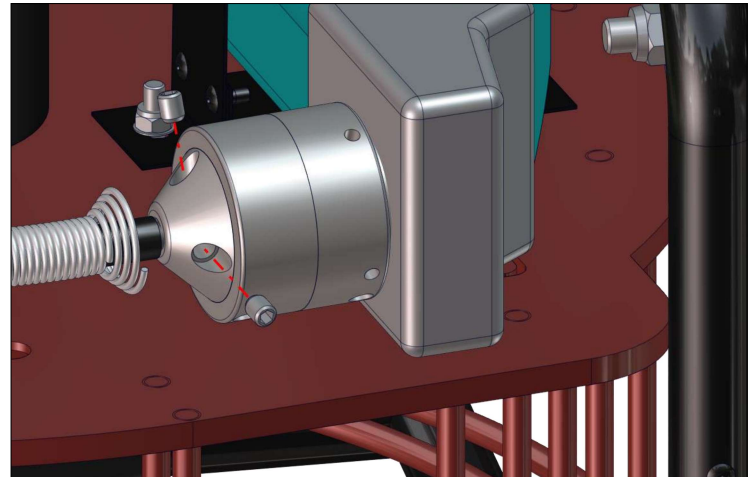

Recommended : use Loctite 542.

INSPECTING FLEXIBLE SHAFT FOR DAMAGE

Carefully inspect the flexible shaft and its casing on a regular basis to ensure that there are no signs of wear and tear. Change the flexible shaft and casing as and when required. Damaged shaft needs to be trimmed back before attaching tools (see examples to right).



SERVICING THE FLEXIBLE SHAFT & ITS OUTER CASING

The flexible shaft is pre-treated with Picote Flexible Shaft Lubricant and the casing replaced prior to shipping. Always inspect the condition of the shaft and its outer casing regularly. Also, inspect at least once a week that the shaft is well attached under the hand guard at the machine end. If the shaft appears to have gaps between the windings from the beginning to the end, the entire shaft will need to be replaced.

Lubricant can be added between the flexible shaft and its outer casing when the shaft is attached to the machine. In order to add lubricant the shaft needs to be disconnected from the clutch and removed from the reel. The shaft needs to be taken out from outer casing about 1–1,5m (3-5ft) and lubricant needs to be added on the other side - inside the cavity. No more than **40ml/40g/1.4oz** will be required for the entire shaft. Too much lubricant can cause a strain on the cable. After the lubricant has been poured, the free shaft end should be pushed through the outer casing. The shaft will push the lubricant evenly inside the outer casing. Connect the shaft to the machine and rotate with low rotation speed so that the shaft will push excess lubricant to the outside. Use a mat to protect the work area under the machine to prevent damage to floors.

Keeping the shaft well lubricated will prolong its life span and decrease the friction caused by the shaft when it turns around. Lower friction will decrease the burden caused to the motor.

If preferred, the shaft can be taken out of its outer casing for lubrication.

Appropriate oil to use: Picote Flexible Shaft Lubricant (available from your reseller)

CHANGING THE FLEXIBLE SHAFT

Only use the shaft and its special outer casing specified by Picote Solutions. Order the replacement shaft from your reseller. The flexible shaft is pre-treated with Picote Flexible Shaft Lubricant and the casing replaced prior to shipping.

1. Loosen the bolts holding the hand guard and remove the hand guard.
2. Open bolt which is holding strain relief spring.
3. Loosen the screws in the safety clutch that hold the shaft. Pull strain relief spring away from the shaft. Pull the old shaft out of the machine.
4. Insert new shaft. Before inserting the shaft inside the safety clutch, add strain relief spring and tighten it. Verify that the shaft goes all the way to the end. Tighten the screws.
5. Mount the hand guard. Tighten the bolts.

FLEXIBLE SHAFT EXTENSION

Flexible extension shafts **are NOT available** for the Mini Cleaner or Mini Cleaner +C. **Do not** extend the shaft with extensions in any situations.

▲WARNING

You must use only the Picote Solutions accessories and attachments with the machine described in this operations manual. The use of other accessories or attachments could present a risk of injury or death. The accessories or attachments should only be used in the proper and intended manner, and always follow Picote Solutions instructions.

MINI CLEANER

3540000816	Mini Cleaner 8/16
3540000816US	Mini Cleaner 8/16 110V US
3540000816UK	Mini Cleaner 8/16 110V UK
3540001816	Mini Cleaner +C EU, 230v with cleaning tools
3540001816UK	Mini Cleaner +C UK, 110v with cleaning tools
3540001816US	Mini Cleaner +C US, 110v with cleaning package
3540001818US	Mini Cleaner +C US, 110v with cutting package

SPARE PARTS

131203108517	Mini Cleaner Replacement Shaft with Spring Casing 16.5m
9311713099	Mini Cleaner Shaft Spring Casing only 16.5m
9530000134-1	Strain Relief Spring Mini Cleaner for Safety Clutch
900001204	Mini Cleaner Safety Clutch
900001203	Silicone Spring for Mini Cleaner (RED)
1350000020	Picote Flexible Shaft Lubricant 0.5 liters
1350000021	Picote Flexible Shaft Lubricant Package, includes 6 bottles

The Picote Mini Cleaner and Mini Cleaner +C machines are delivered with special tools for small pipe cleaning & descaling. Tools are available for larger pipe sizes. Please consult The Mini Cleaner Quick Guides on the Picote Institute for the full range of tooling options.

MINI CLEANER TOOL PACKAGES

3540000816TK	Mini Cleaner Tool Kit
35400000818CU	Mini Cleaner Cutting Package
35400000818CL	Mini Cleaner Cleaning Package
3540000816TK	Mini Cleaner Tool Kit
1000818025	Hub 8.5x18x25 (DN32-40)
1381084032	Cleaning Chain DN32
1381084040	Cleaning Chain DN40
2125000032CL	Cleaning Brush DN32
2125000040CL	Cleaning Brush DN40
1240035045	Cleaning Panel DN32 35x45 (10 pcs)
1240040050	Cleaning Panel DN40 40x50 (10 pcs)

ACCESSORIES & SPARE PARTS

SAVE ALL WARNINGS AND INSTRUCTIONS FOR FUTURE REFERENCE

3540000818CU	Mini Cleaner Cutting Package (USA)
1360080051	Smart Sweeper Head DN40-DN50 (1.½"-2")
1000818025	Smart Cleaner Hub 8.5x18x25 DN32-DN40 (1¼"-1.½")
1201030050	Side Grinding Panel 30x50 DN40 (1.½") Package
1230000054	Twister Mini Flexi DN50 (2")
3540000818CL	Mini Cleaner Cleaning Package (USA & ROW)
1360080051	Smart Sweeper Head DN40-DN50 (1.½"-2")
1000818025	Smart Cleaner Hub 8.5x18x25 DN32-DN40 (1¼"-1.½")
1201030050	Side Grinding Panel 30x50 DN40 (1.½") Package
1381084040	Cleaning Chain DN40 (1.½")
1300212025	Front Drill Head 25mm for DN50 (2") pipes
PIPE CLEANING TOOLS FOR SMALL PIPES:	
1000818025	Smart Cleaner Hub 8.5x18x25 DN32-DN40 (1¼"-1.½")
1240035045	Cleaning Panel DN32 / 1¼" Package (35x45)
1240040050	Cleaning Panel DN40 / 1.½" Package (40x50)
1381084032	Cleaning Chain DN32 / 1¼"
1381084040	Cleaning Chain DN40 / 1.½"
2125000032CL	Cleaning Brush DN32 / 1¼"
2125000040CL	Cleaning Brush DN40 / 1.½"
1381084070P	Cyclone DN70/ 3" for 8mm / ½" Shaft PVC
1380084050P	Original DN50 / 2" PVC
2120000075	Cleaning Brush DN50 / 2"
2120000100	Cleaning Brush DN70 / 3"
1201025040	Side Grinding Panel DN32 / 1¼"Package (25x40)
1201030050	Side Grinding Panel DN40 / 1.½" Package (30x50)
1360080051	Smart Sweeper Head DN40-DN50 / 1.½"-2"
1360080071	Smart Sweeper Head DN70 / 3"
1300212025	Front Drill Head 25mm for DN50 / 2" pipes
1300214042	Front Drill Head 35-40mm for DN70 / 3" pipes
900000935	Mini Sweeper Leg DN50 / 2"
900000942	Mini Sweeper Leg DN70 / 3"
1230000054	Twister Mini Flexi DN50 / 2"
1230000074	Twister Mini Flexi DN70 / 3"
1310820029	Special Drill Head Cutter DN32-DN40 / 1¼"-1.½" (8x20x29)

Here are some useful tips on how to get the most out of your Picote system. Always use the recommended tools for maintenance to avoid personal injury.



CUTTING THE FLEXIBLE SHAFT



Always inspect the flexible shaft before each use. Run the machine briefly in clockwise direction to allow the shaft to return to its resting position. If there are potential weak points or the shaft is damaged, cut off the damaged length using a band saw. For most tools, the shaft should extend ~40mm (1 ½") past the casing. Hubs and Original chains without a leader require more exposed shaft.

CUTTING THE OUTER CASING



Always inspect the outer casing before each use. The easiest and safest way to shorten the outer casing to the correct length is using a sheath cutter. Only the necessary amount of bare shaft should be exposed at any time.



SHAFT ROUNDER



The Shaft Rounder is used to smooth the end of the flexible shaft, preventing the user from being cut by the otherwise sharp metal edge.



PRACTICAL TIPS & SAFETY ADVICE

SAVE ALL WARNINGS AND INSTRUCTIONS FOR FUTURE REFERENCE

Here are some useful tips on how to get the most out of your Picote system.
Always use the recommended tools for maintenance to avoid personal injury.



CREATING LEADERS

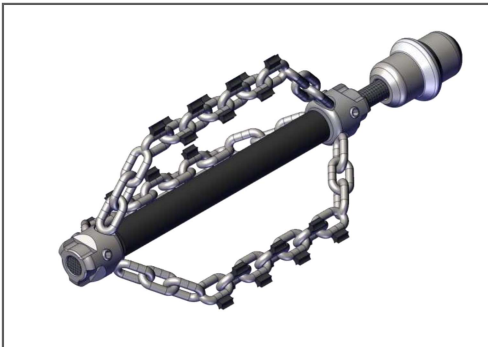

You can extend the life of the flexible shaft and increase productivity on site by making individual leaders for the most commonly used tools. This way you easily and quickly switch between tools. **Leaders should always be used if the situation permits it.**



ADDING A VISUAL MARKER FOR SAFETY



If not using a “leader” attach a visual marker (tape) on the outer casing of the flexible shaft. Place it around 500mm (20”) from the end of the shaft. The marker will indicate the tools location and help prevent possible injury from the rotating parts by alerting you when the tool is about to exit the pipe.



MINI CLEANER +C 8/16

SAVE ALL WARNINGS AND INSTRUCTIONS FOR FUTURE REFERENCE



This machine is intended for the following uses:

1. Tool for inspecting pipes before, during and after work (Navigates through DN50 (2") bends and P-traps)
2. pipe work as the CCTV camera is fitted with a integrated Sonde (512 hz)

Always follow Picote Solutions instructions when installing and using the machine with accessories.

CAUTION

This section contains operating instructions only for Mini Cleaner +C camera kit

BEFORE OPERATION:

1. Before using the +C camera kit, install an SD card to SD card slot.
2. Connect DVR to camera reel with included cable



STARTING & USING THE MACHINE

DVR Icons:

1. SD Card
2. Battery level
3. Image Reverse
4. Image Reverse & Mirror
5. Image Mirror
6. Timestamp
7. LED Brightness
8. Record
9. Meter Counter





1. Live video

Press  to turn on/off the DVR

Press  to start/stop recording

Press  to mirror or/and reverse the image

Press  to adjust the brightness of the camera LEDs

Press  to take a picture

2. Video settings menu

Press  to enter settings menu

Use  and  to navigate in the menu

Press  to confirm the selection

Press  to exit to exit the settings menu

3. Playback menu

Press  to enter playback mode

Use  and  to browse through the files

Press  to confirm the selection and preview media files

Use  and  to preview previous/next file

Press  to playback video

Press  to enter the play settings

4. Playing video

Press  to play/pause the video

Press  to stop playing the video

Press  to rewind

Press  to forward

Press  to change rewind/forward speed

5. DVR settings menu

Press  to enter video settings,

then press  to enter DVR settings

	ITEM	PARAMETER
General	Unit Weight	14 Kg / 31 lbs
Camera	Camera Size	Φ14mm×20.5mm (Main body)
	Video Resolution	PAL 720×576 25FPS Max. NTSC 720×488 30FPS Max
	Front Lens	Sapphire
	Shell Material	304# Stainless Steel
	Lighting	Built-in 4xLED (White)
	Water-Proof	20 m / 65ft Water
	Power Consumption	40 mA (LED OFF), 60 mA (LED ON)
DVR	Screen	7-inch 16:9 color LCD screen
	Screen Resolution	800x480 RGB
	Features	Sonde, image mirror, image flip
	External Memory	SD Memory Card up to 32GB
	Cable Length	30 m / 100ft
	Meter Counter	Yes
	Single Charge Work Time	6 Hours
	Charging time	8 Hours
	Language	English, German, French, Spanish, Italian, Chinese, Japanese, Russian, Portuguese
Tool Box	Size	380x260x150 mm (15x10x6 in.)(L x W x H)

SAVE ALL WARNINGS AND INSTRUCTIONS FOR FUTURE REFERENCE

MINI CLEANER +C update kit

3540002000EU	Mini Cleaner +C EU
3540002000US	Mini Cleaner +C US
3540002000UK	Mini Cleaner +C UK
3540002000AU	Mini Cleaner +C AU

SPARE PARTS

900001760	Mini Cleaner +C Camera Head
900001754	Mini Miller +C Camera Head
900001688	+C Charger EU
900001691	+C Charger US
900001689	+C Charger UK
900001804	Mini Miller +C Camera Rod
900001805	Mini Cleaner +C Camera Rod
900001758	Electric cable +C
900001755	Monitoring Box +C

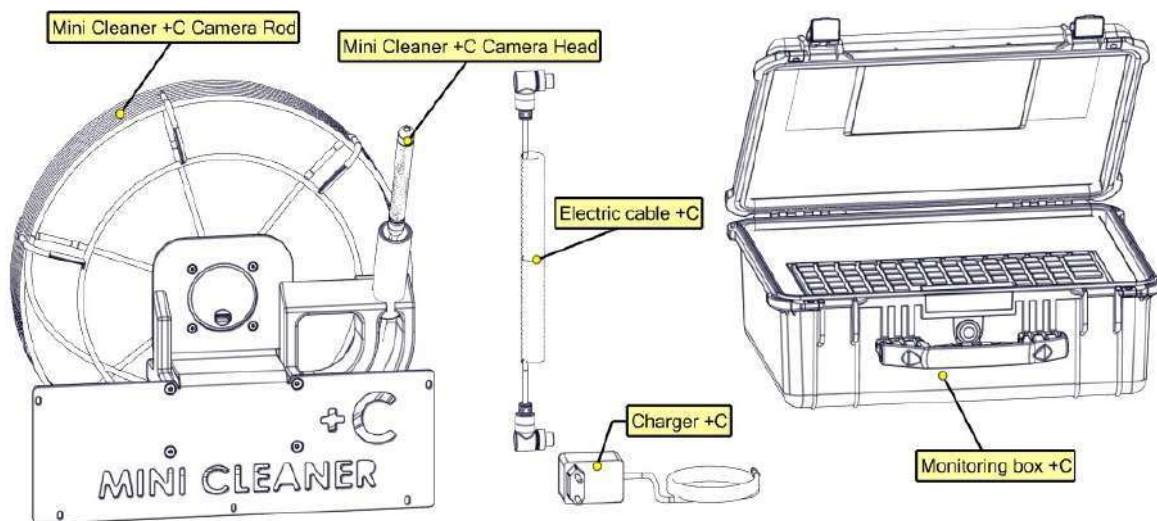

Number (config)	Description (config)	Qty
900001758	Electric cable +C	1
900001688 (EU), 900001691 (US), 900001689 (UK), 900001690 (AU)	Charger +C	1
900001760	Mini Cleaner +C Camera Head	1
900001755	Monitoring box +C	1
900001805	Mini Cleaner +C Camera Rod	1

TROUBLESHOOTING FLOWCHART

SAVE ALL WARNINGS AND INSTRUCTIONS FOR FUTURE REFERENCE

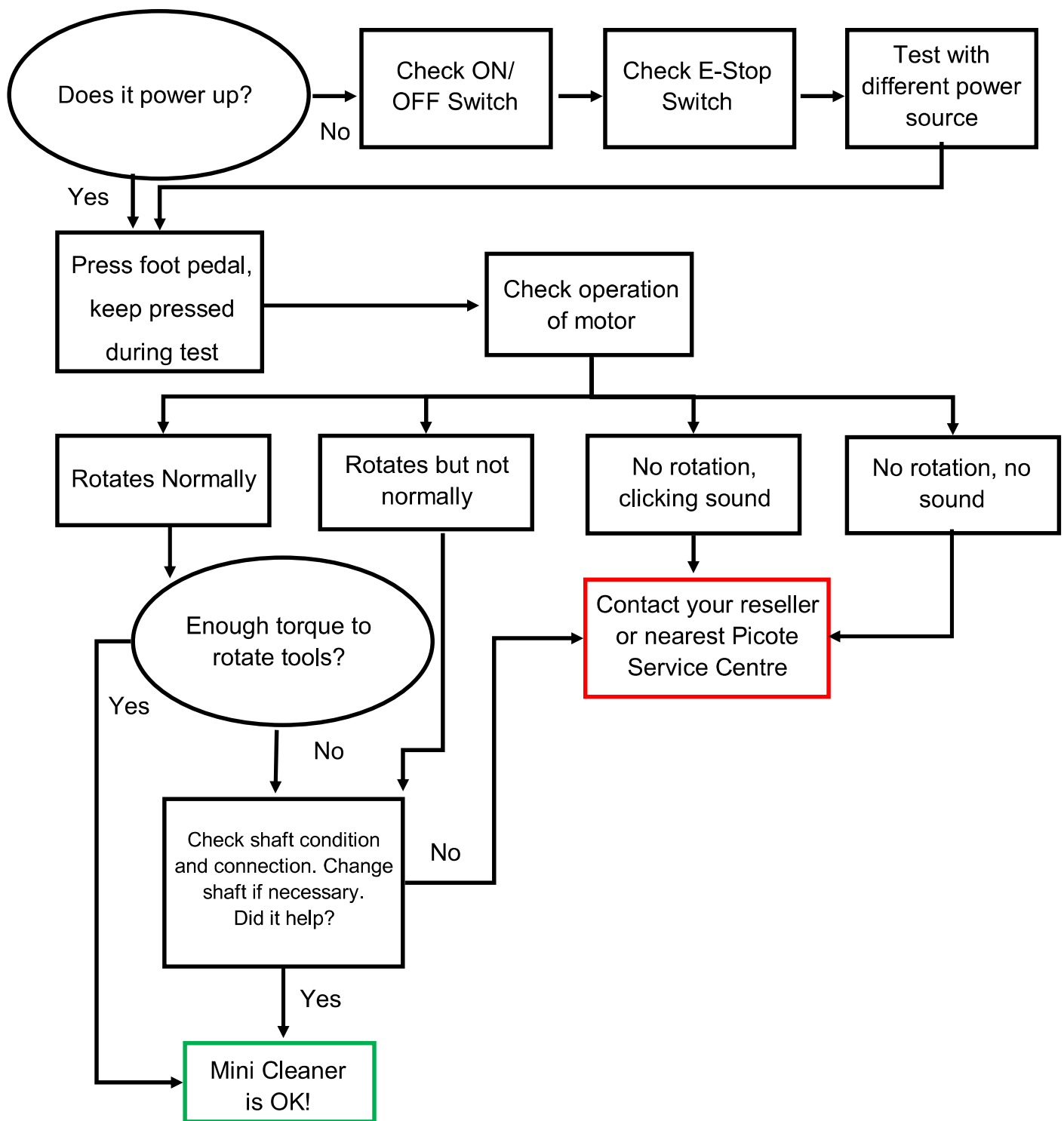

If there is problem that you cannot resolve with this manual, please consult your Picote Reseller or Picote Solutions.

Limited Warranty:

Picote warrants to the original End User that the Product purchased by such End User will operate in accordance with, and substantially conform to their published specifications when shipped or otherwise delivered to the End User and for a period of one (1) year, except electric motors for which the warranty period shall be six (6) months, provided, however, that Picote does not warrant any claim or damage under this Warranty if such claim or damage results from:

1. Consumable parts or normal wear and tear resulting from use of the Products,
2. Product overload or overheated motor,
3. Regular periodic maintenance of Products,
4. Misuse, neglect, or improper installation or maintenance of the Products, or use of Products not for their intended purpose,
5. Products that have been altered, modified, repaired, opened or tampered with by anyone other than Picote or an authorized Picote Service Centre, or unsuitable or unauthorized spare parts, accessories or third party products when using the Products or;
6. the use of the Products not in compliance with their respective Documentation, user manuals, safety and maintenance instructions, and any usage restrictions contained therein, or
7. accident, fire, power failure, power surge, or other hazard.

Otherwise, the Products are sold AS IS. End User is responsible for using the Products within their specifications and instructions as contained in the Documentation.

EXCEPT AS SPECIFIED IN THIS WARRANTY, ALL EXPRESS OR IMPLIED CONDITIONS, REPRESENTATIONS, AND WARRANTIES INCLUDING, WITHOUT LIMITATION, ANY IMPLIED WARRANTY OR CONDITION OF MERCHANTABILITY, FITNESS FOR A PARTICULAR PURPOSE, NONINFRINGEMENT, SATISFACTORY QUALITY OR ARISING FROM A COURSE OF DEALING, LAW, USAGE, OR TRADE PRACTICE, ARE HEREBY EXCLUDED TO THE EXTENT ALLOWED BY APPLICABLE LAW. TO THE EXTENT AN IMPLIED WARRANTY CANNOT BE EXCLUDED, SUCH WARRANTY IS LIMITED IN DURATION TO THE WARRANTY PERIOD. BECAUSE SOME STATES OR JURISDICTIONS DO NOT ALLOW LIMITATIONS ON HOW LONG AN IMPLIED WARRANTY LASTS, THE ABOVE LIMITATION MAY NOT APPLY. This disclaimer and exclusion shall apply even if the express warranty set forth above fails of its essential purpose.

Revision number: Rev. 5

Author: Ville Hukkanen

Accepted: Dawn Greig 25/11/20

Date: NOV. 2020

Please Contact:

Your Reseller / Salesperson or Picote

www.picotesolutions.com



International Offices

Finland. United Kingdom. USA.

Technical Support

support@picotesolutions.com

Production & R&D

Pienteollisuustie 24
06450 Porvoo, Finland
support@picotesolutions.com

Claims

claims@picotesolutions.com

Authorized Resellers:

www.picotesolutions.com/resellers