

Display Cabinet

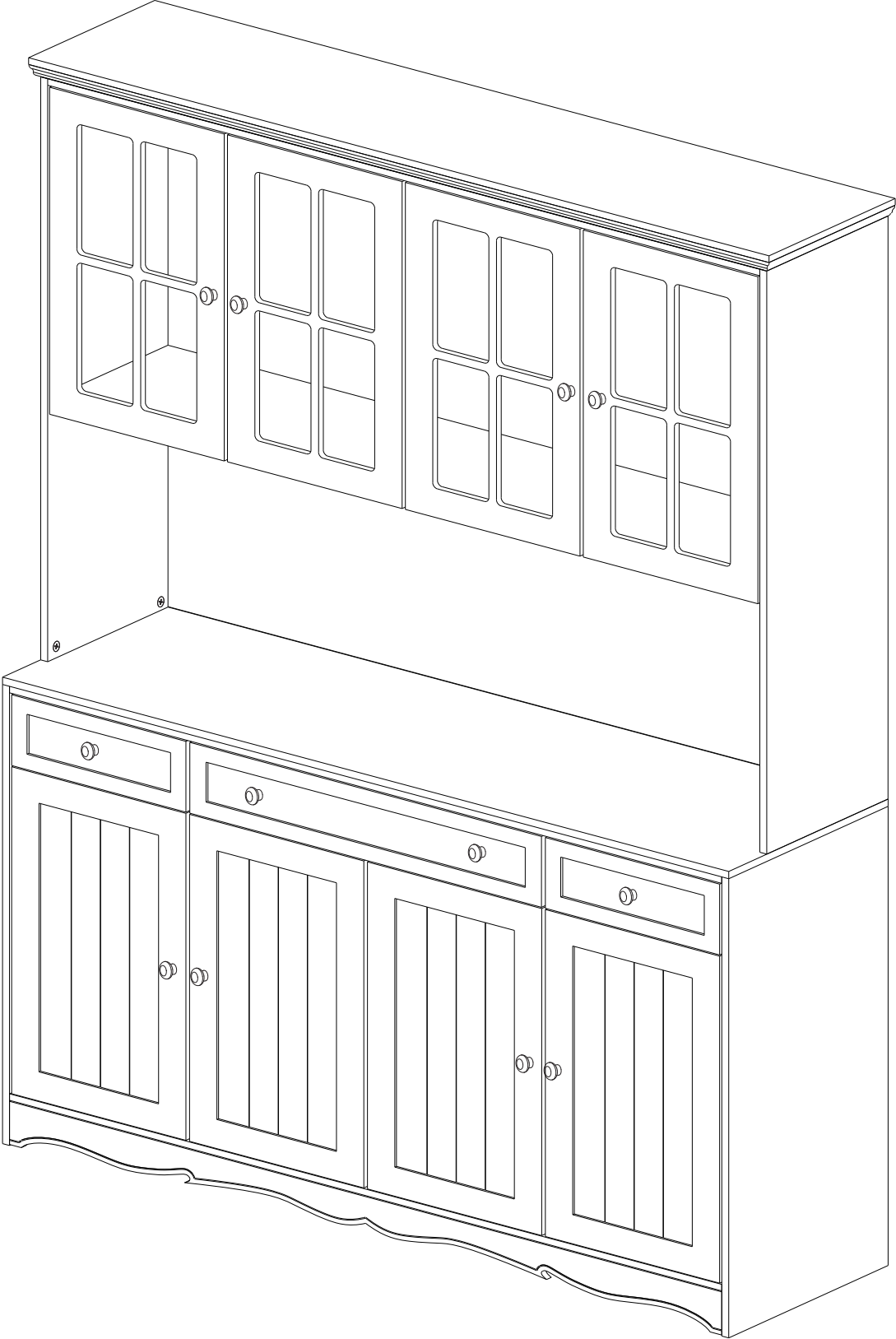

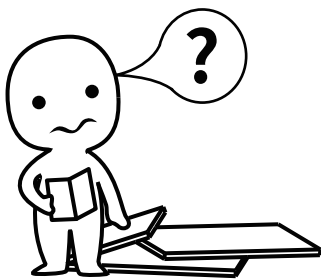

IMPORTANT INFORMATION!

please read the entire manual before starting to assemble and/or using this product. follow the manual thoroughly and keep it for further reference.

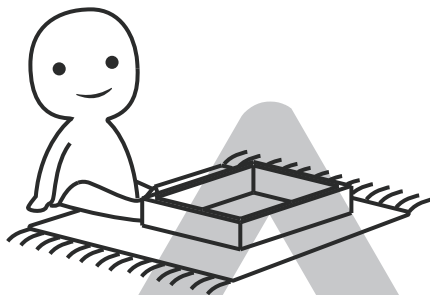
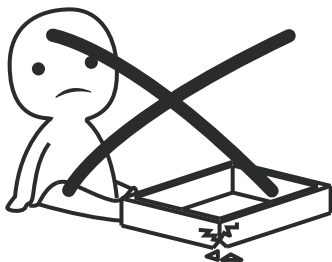

AVOID SCRATCHES!

In order to avoid scratching this furniture should be assembled on a soft layer- could be a rug.

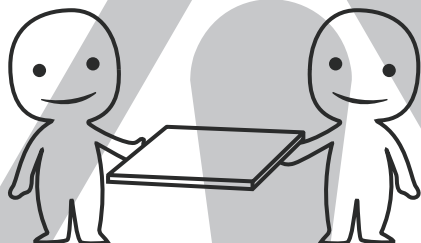

IMPROVE EFFICIENCY !

Try to find a partner to install with you, which can speed up the installation efficiency and shorten the time.

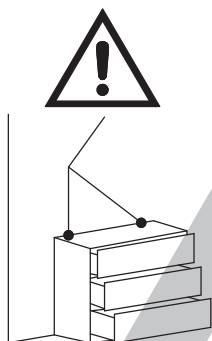

ANTI-TOPPLE WARNING !

Overturnd furniture can cause serious or fatal crush injuries. To prevent tipping over, be sure to use the wall attachment, if not included with this product. Please purchase the wall attachment that fit your wall. If unsure, seek professional advice. Please read and follow each step of the instructions carefully.

IMPORTANT !

It is important that any product which is assembled using any kind of screw is re-tightened 2 weeks after assembly, and once every 3 months - in order to assure stability through-out the lifespan of the product.

For regular maintenance and cleaning of the product, for the frame, please use a rag dipped in neutral detergent to fully wipe it, and then dry it with a clean rag. For glass materials, wipe with a rag dampened with water glass cleaner, and then dry with a dry rag.

Do not use an electric screwdriver, and do not use too much force when installing, because the board is easy to break.

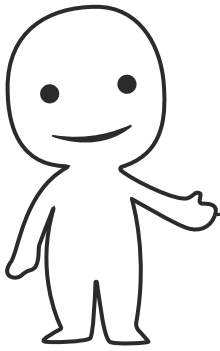

Please prepare the following tools

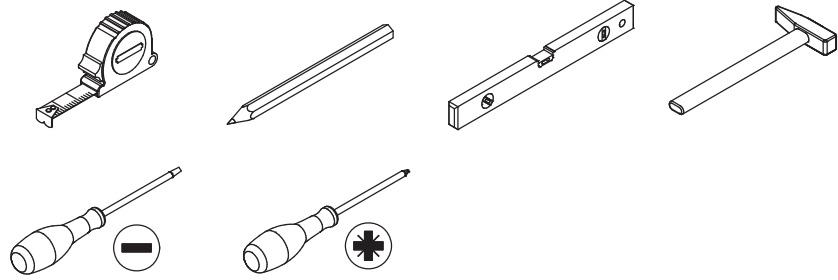

When installing, please carefully confirm whether each screw corresponds to the manual, accessories with similar shapes can be distinguished by size

A x 82

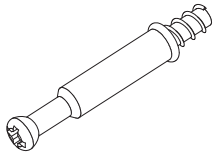

∅6 x 35 mm

B x 82



∅15 x 12 mm

C x 124



∅3 x 12 mm

D x 12

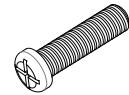

∅4 x 16 mm

CL x 6

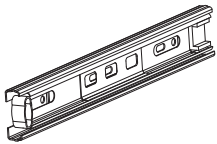

CR x 6

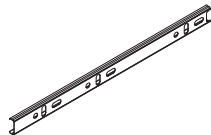

G x 8

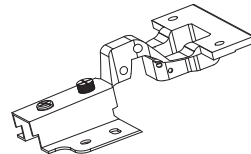

H x 16

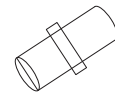

I x 12

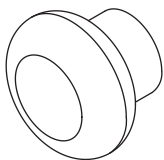

J x 2

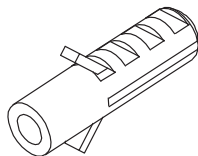

K x 4

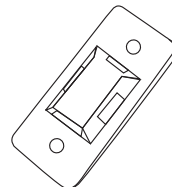

L x 2

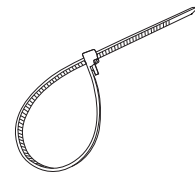

M x 8

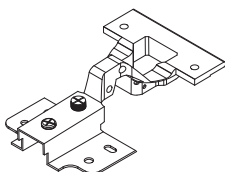

N x 1

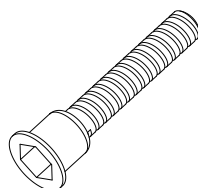

∅6 x 40 mm

O x 24

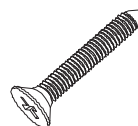

∅4 x 30 mm

P x 1

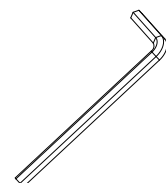

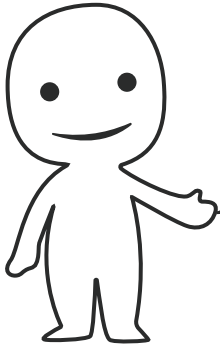

Please prepare the following tools

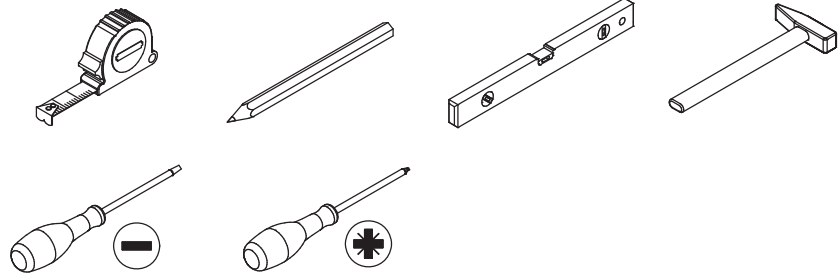

When installing, please carefully confirm whether each screw corresponds to the manual, accessories with similar shapes can be distinguished by size

R x 16



S x 16



∅3 x 16 mm

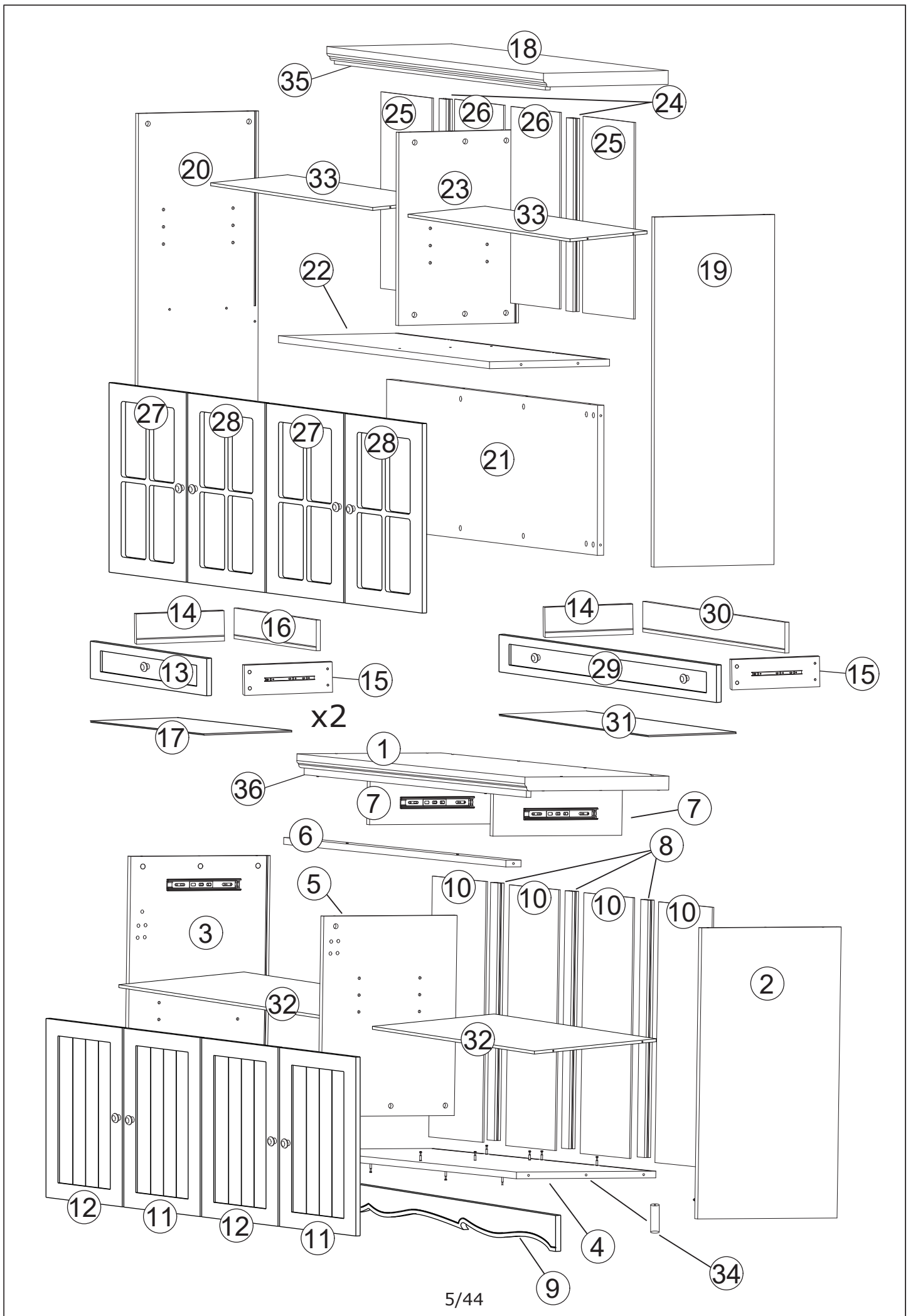

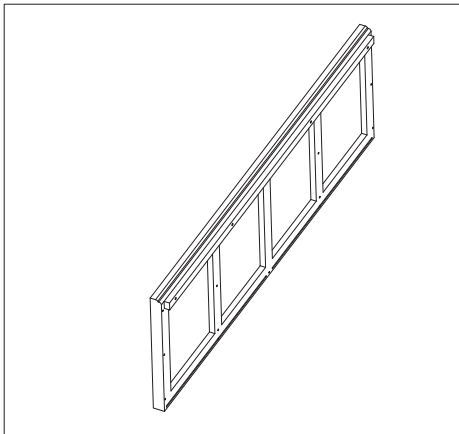

1 | 1 PC

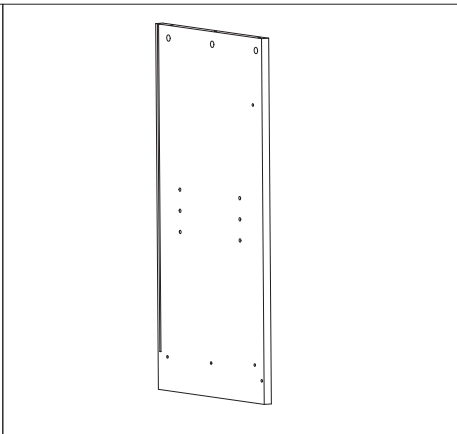

2 | 1 PC

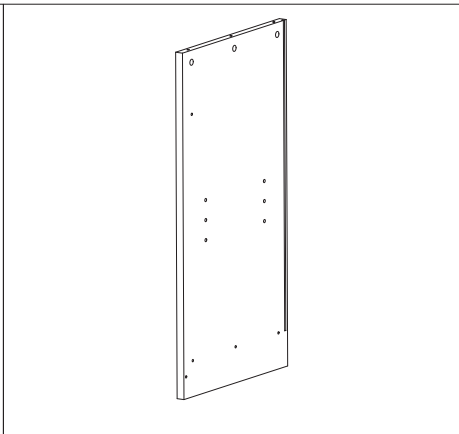

3 | 1 PC

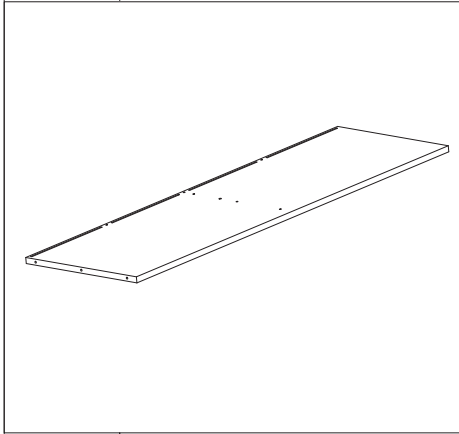

4 | 1 PC

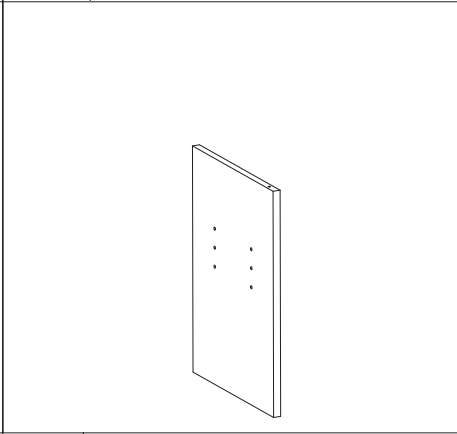

5 | 1 PC

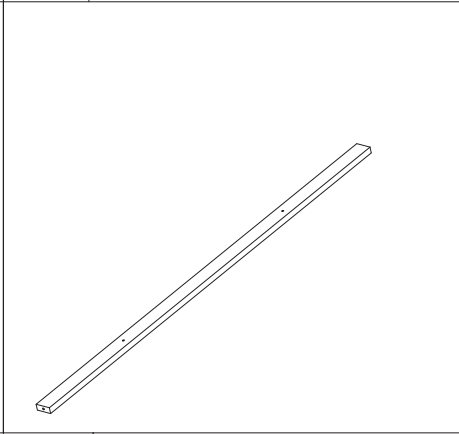

6 | 1 PC

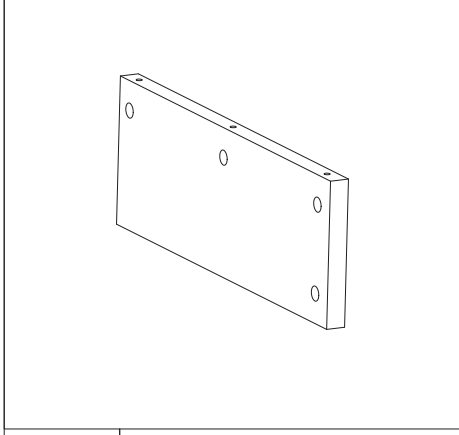

7 | 2 PCS

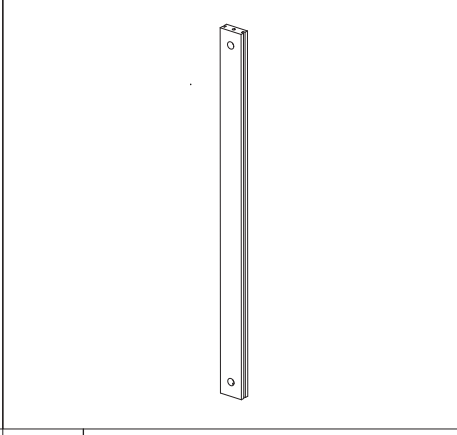

8 | 3 PCS

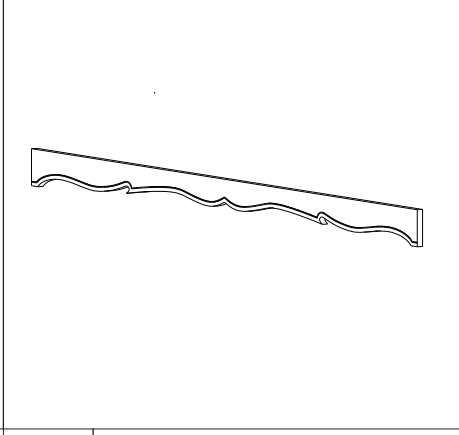

9 | 1 PC

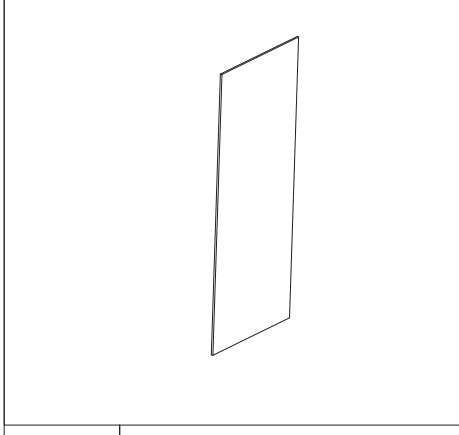

10 | 4 PCS

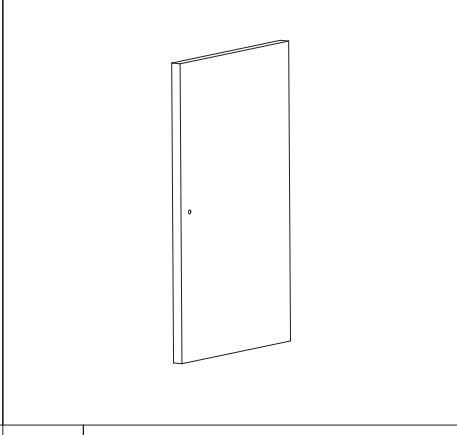

11 | 2 PCS

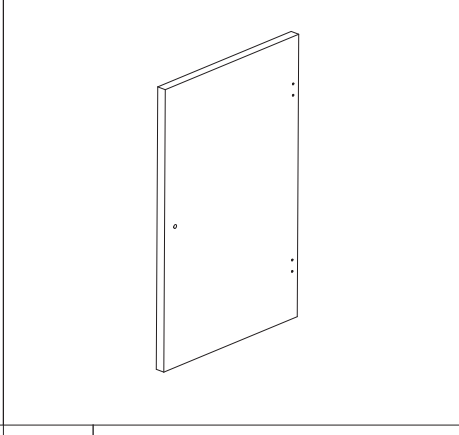

12 | 2 PCS

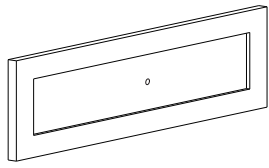

13 2 PCS

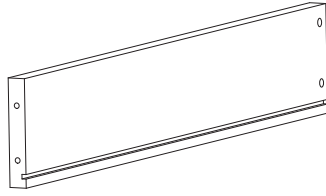

14 3 PCS

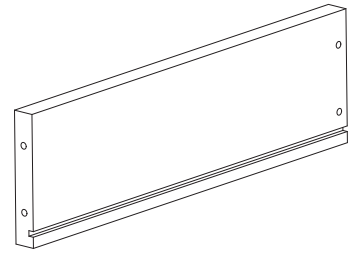

15 3 PCS

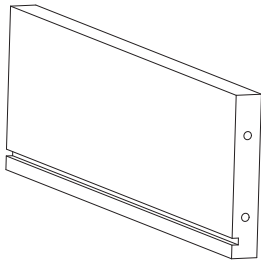

16 2 PCS

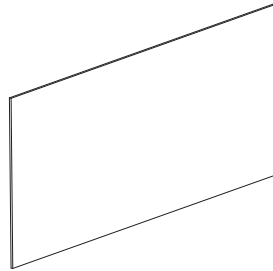

17 2 PCS

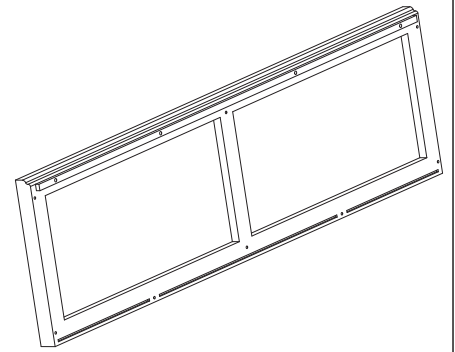

18 1 PC

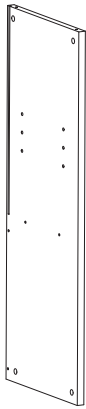

19 1 PC



20 1 PC

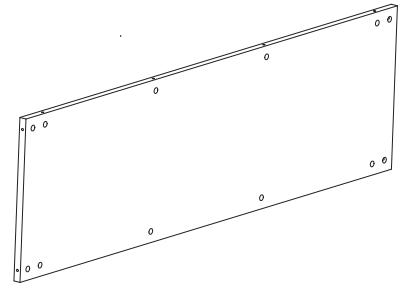

21 1 PC

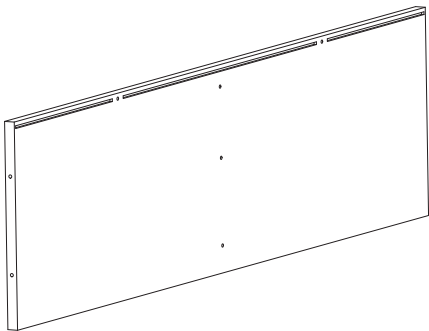

22 1 PC

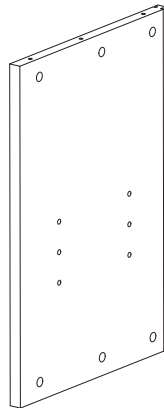

23 1 PC



24 2 PCS

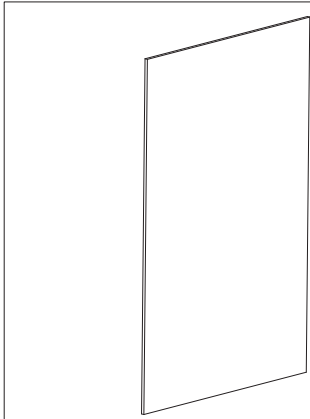

25 | 2 PCS

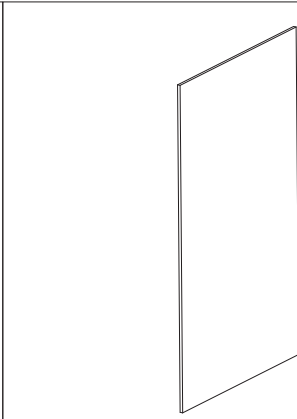

26 | 2 PCS

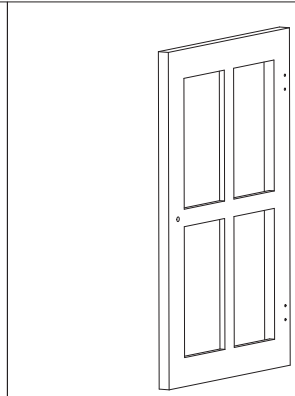

27 | 2 PCS

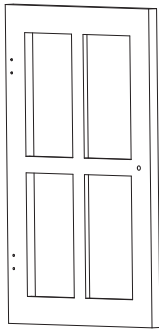

28 | 2 PCS

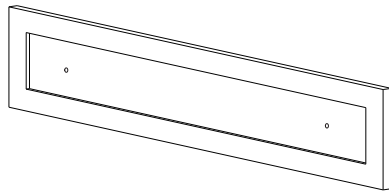

29 | 1 PC

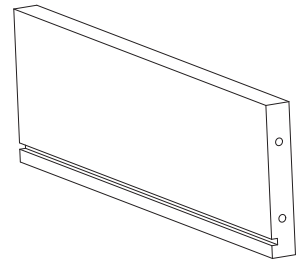

30 | 1 PC

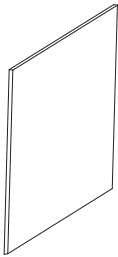

31 | 1 PC

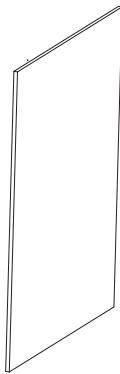

32 | 2 PCS

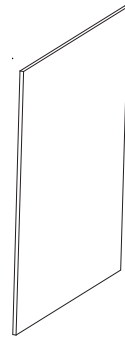

33 | 2 PCS

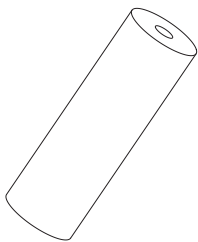

34 | 1 PC

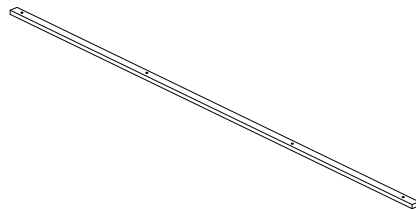

35 | 1 PC

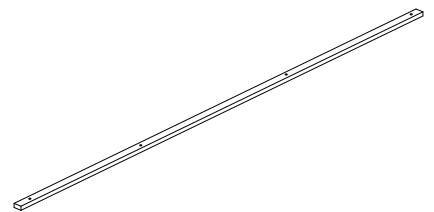

36 | 1 PC

1

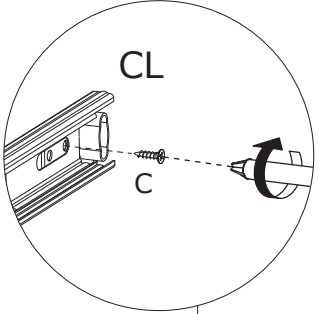
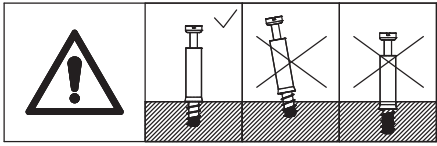
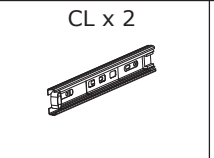
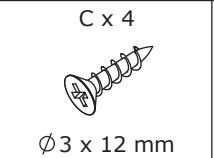
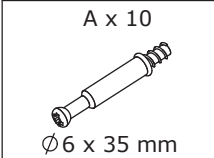

Insert quickfit screw(A) into corresponding holes in plate 2 and 3 with a screwdriver as shown.
Fix slide rail(CL) to plate 2 and 3 using screw(C) as shown.

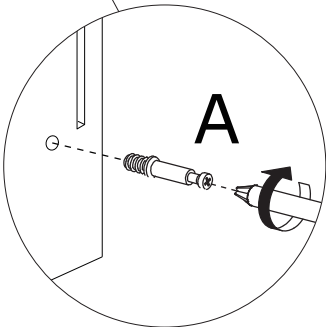
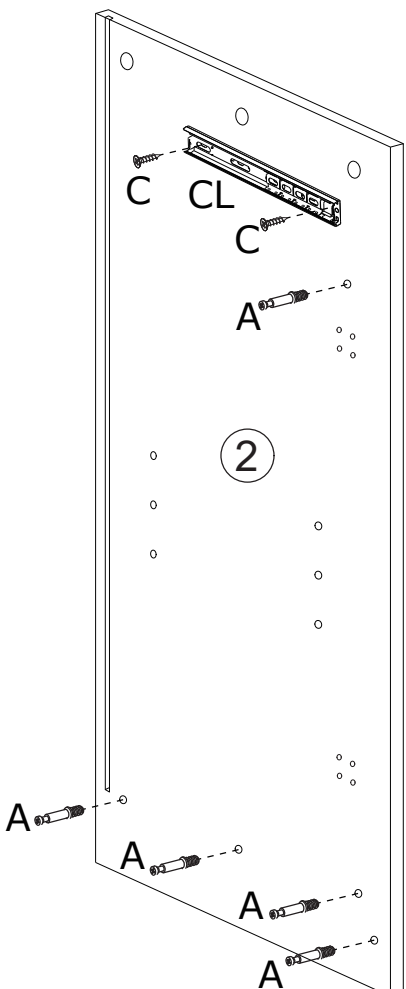
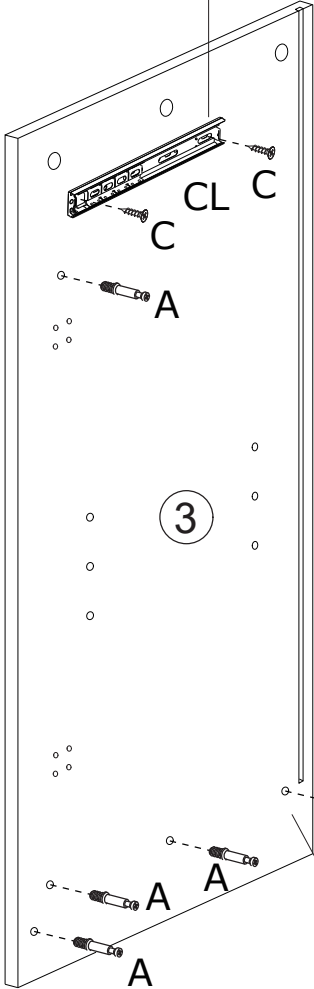

2

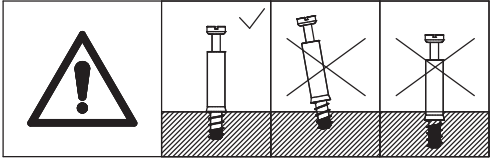
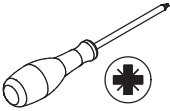
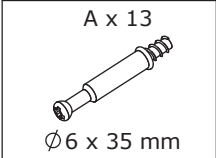

Insert quickfit screw(A) into corresponding holes in plate 4 and 6 with a screwdriver at first.

Flip the two plate, and insert quickfit screw(A) as well.

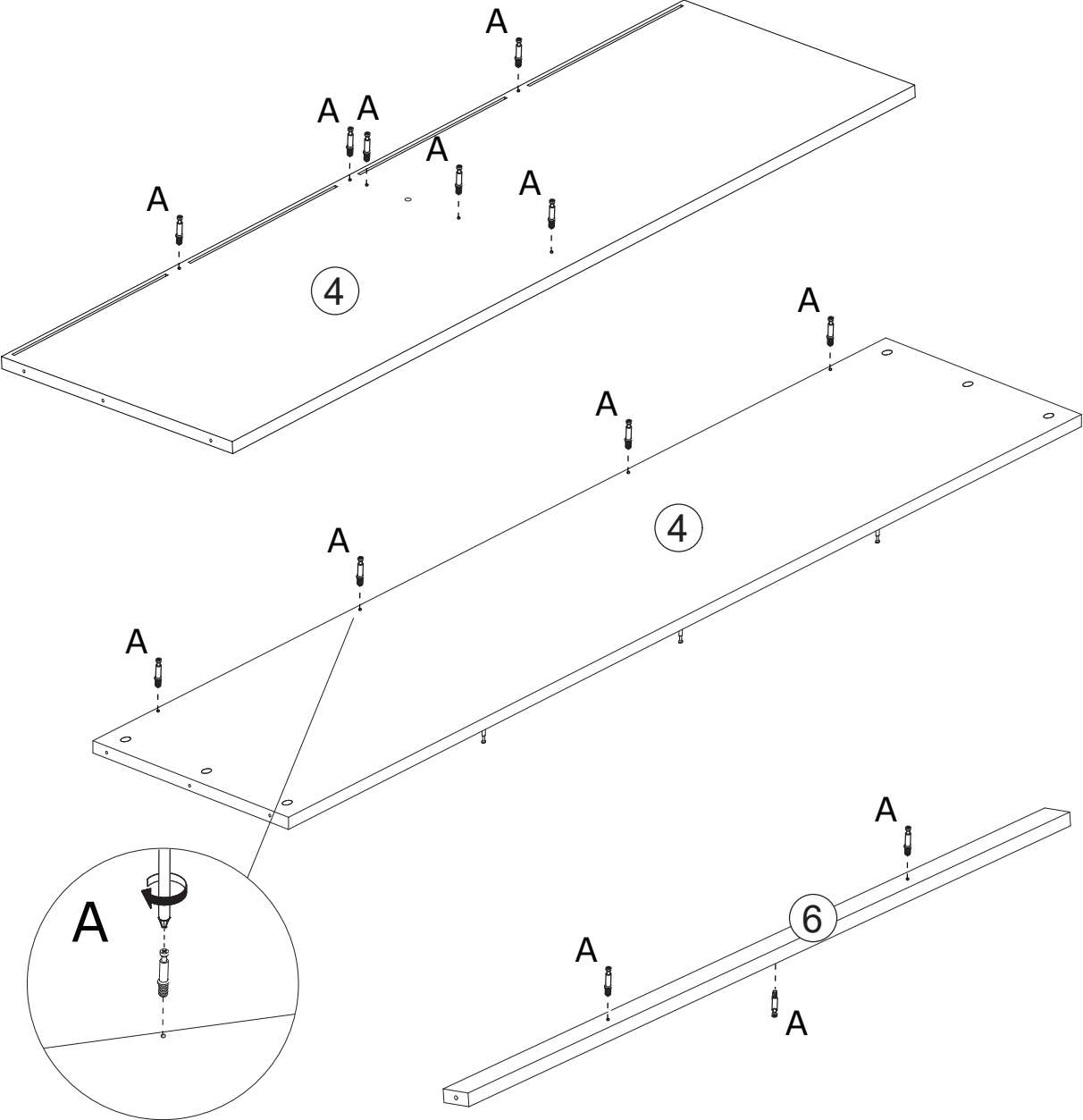

3

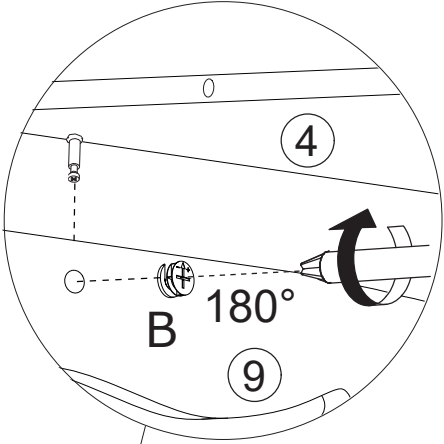
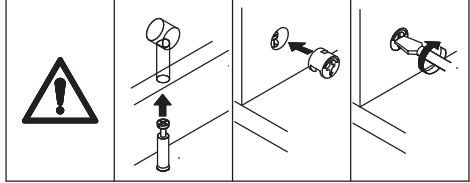
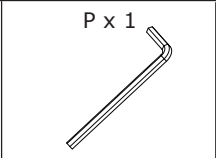
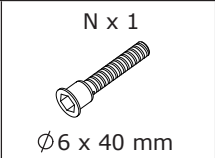
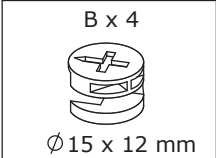

Connect plate 4 with plate 9, insert cam lock(B) into holes in plate 9 and turn clockwise to tighten as shown.

Fix leg support 34 to plate 4 using screw(N) as shown.

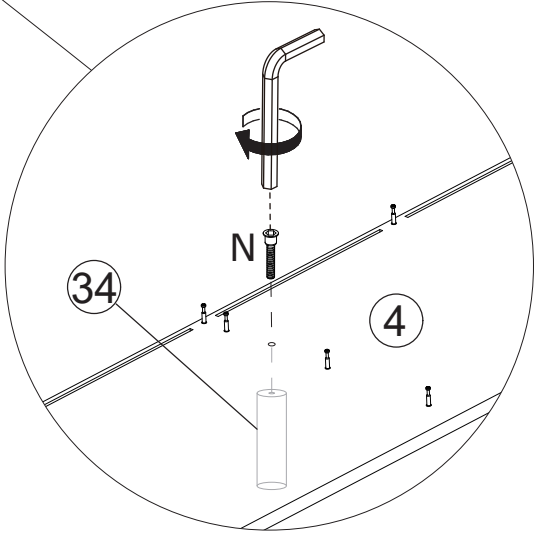
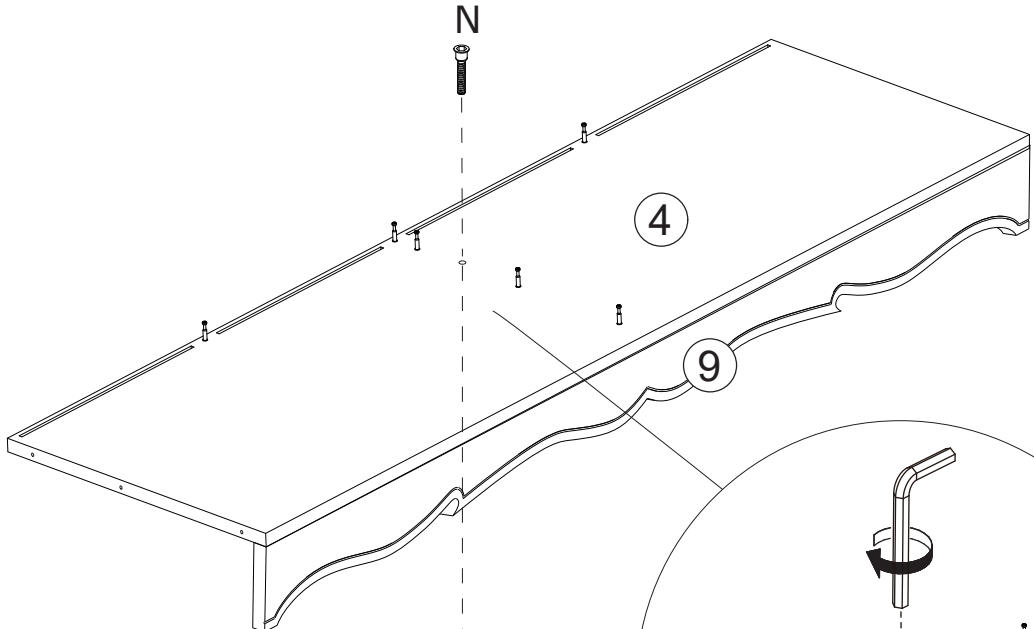
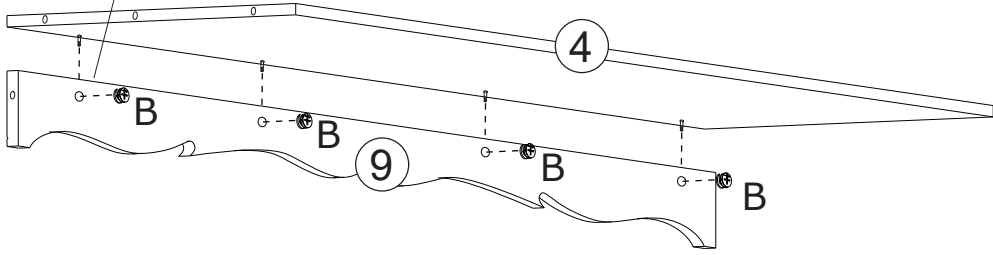

4

B x 4
Ø15 x 12 mm

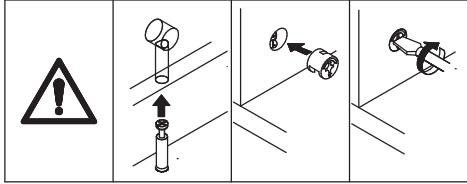
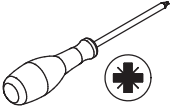

Connect plate 4 and 6 with plate 5, insert cam lock(B) into holes in plate 5 and turn clockwise to tighten as shown.

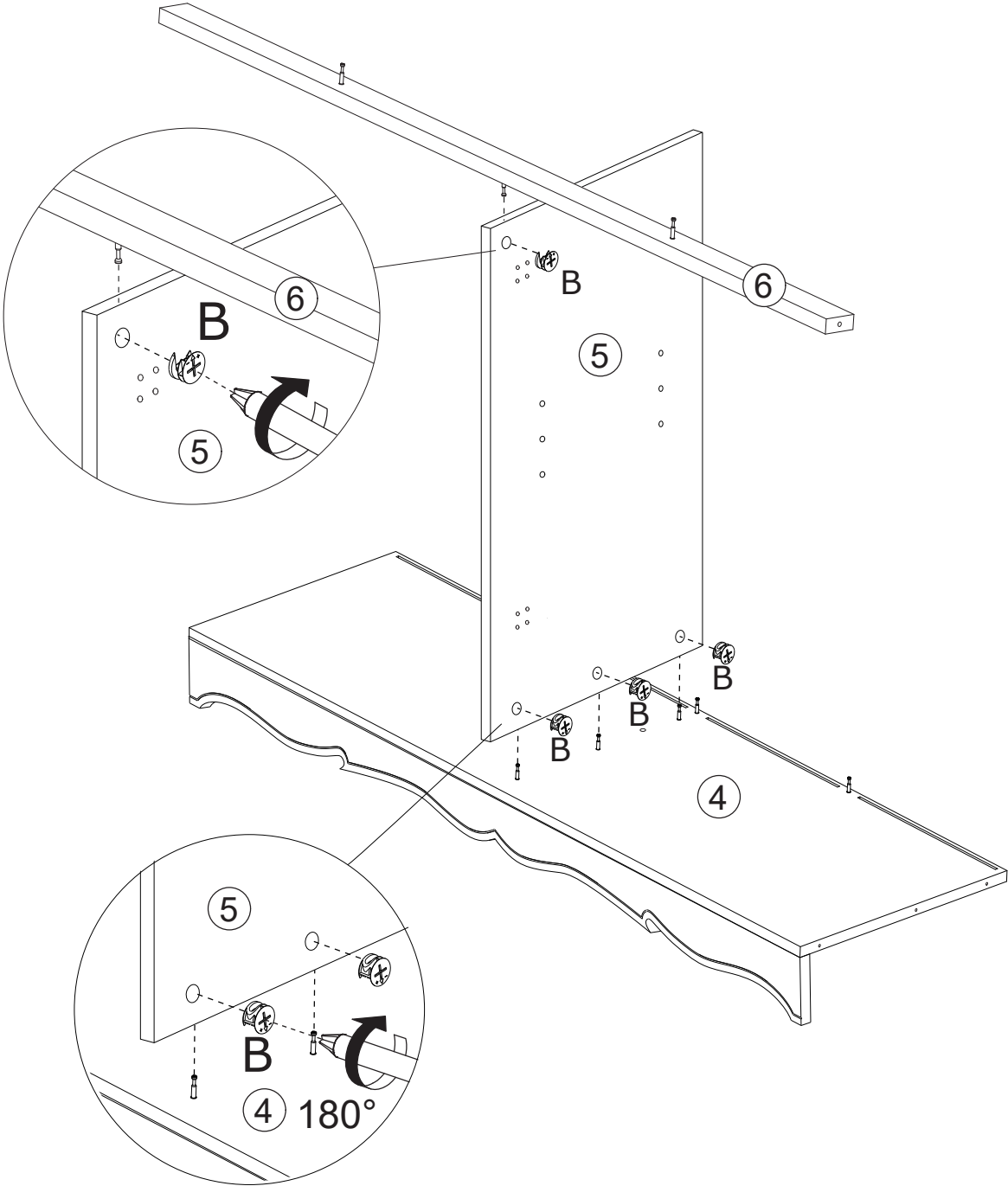

5

B x 10
Ø15 x 12 mm

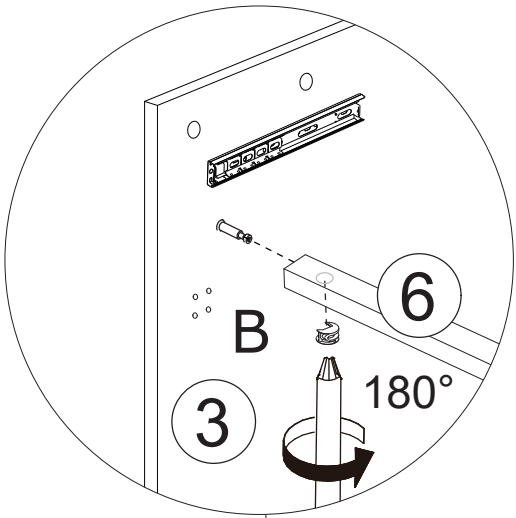
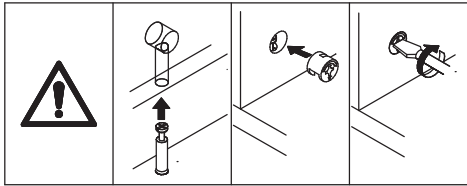
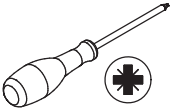

Connect plate 2 and 3 with plate 4,9 and 6, insert cam lock(B) into holes in plate 4,9,6 and turn clockwise to tighten as shown.

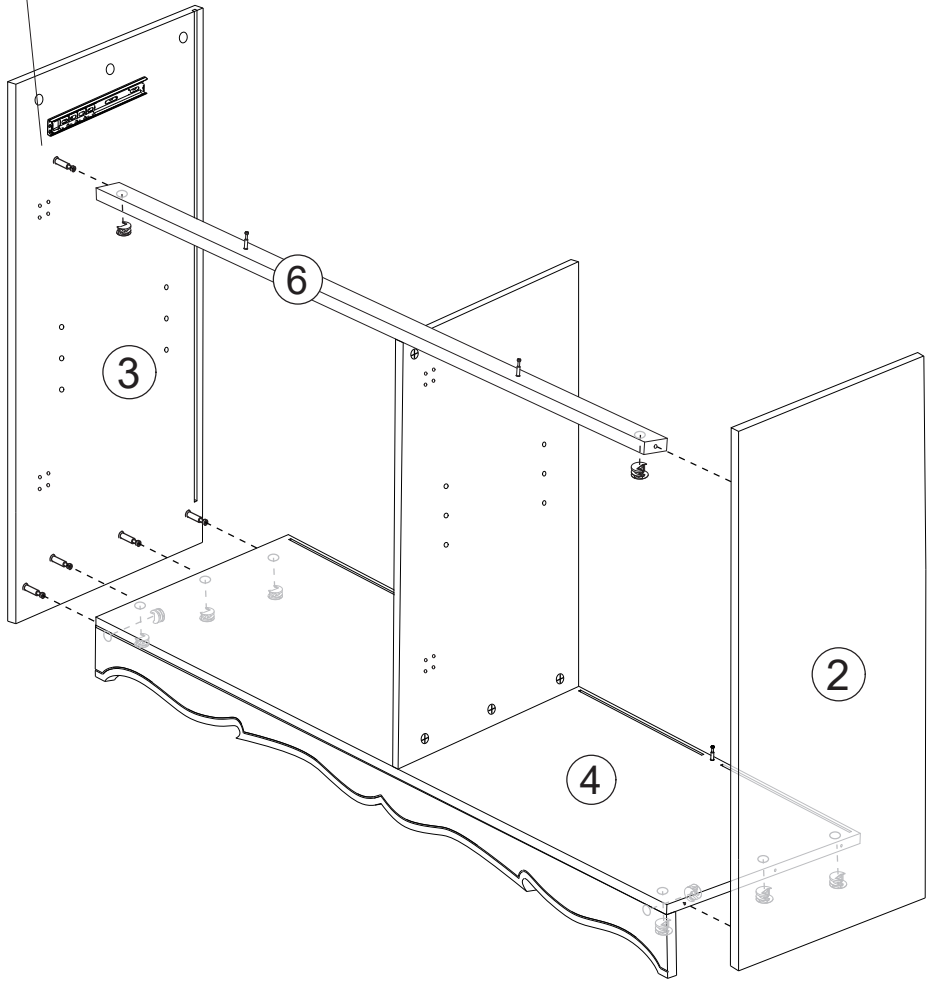

6

B x 3
Ø 15 x 12 mm

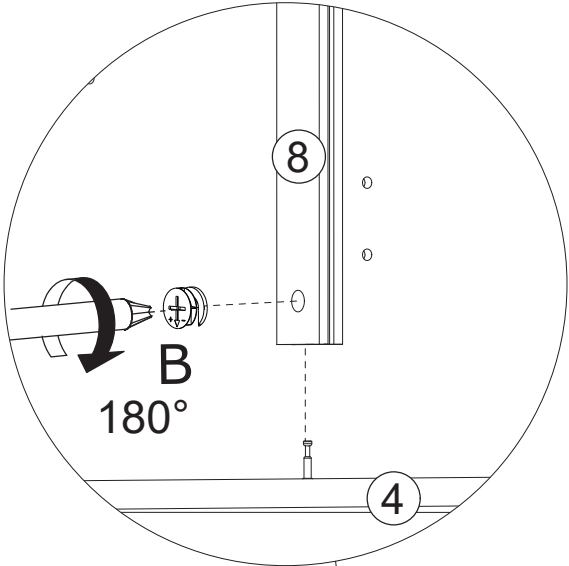
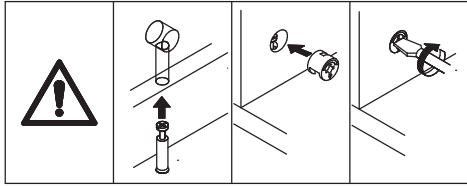
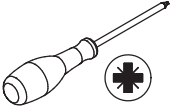

Attach plate 8 to plate 4, insert cam lock (B) into holes in plate 8 and turn clockwise to tighten as shown.

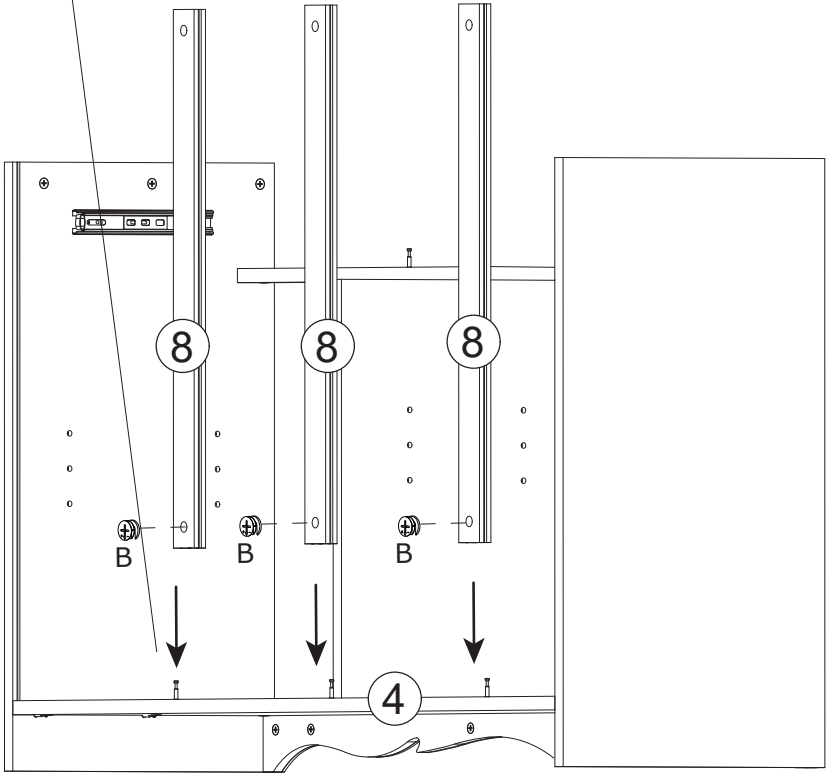

7

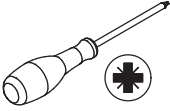

Slide plate 10 into available slots as shown.

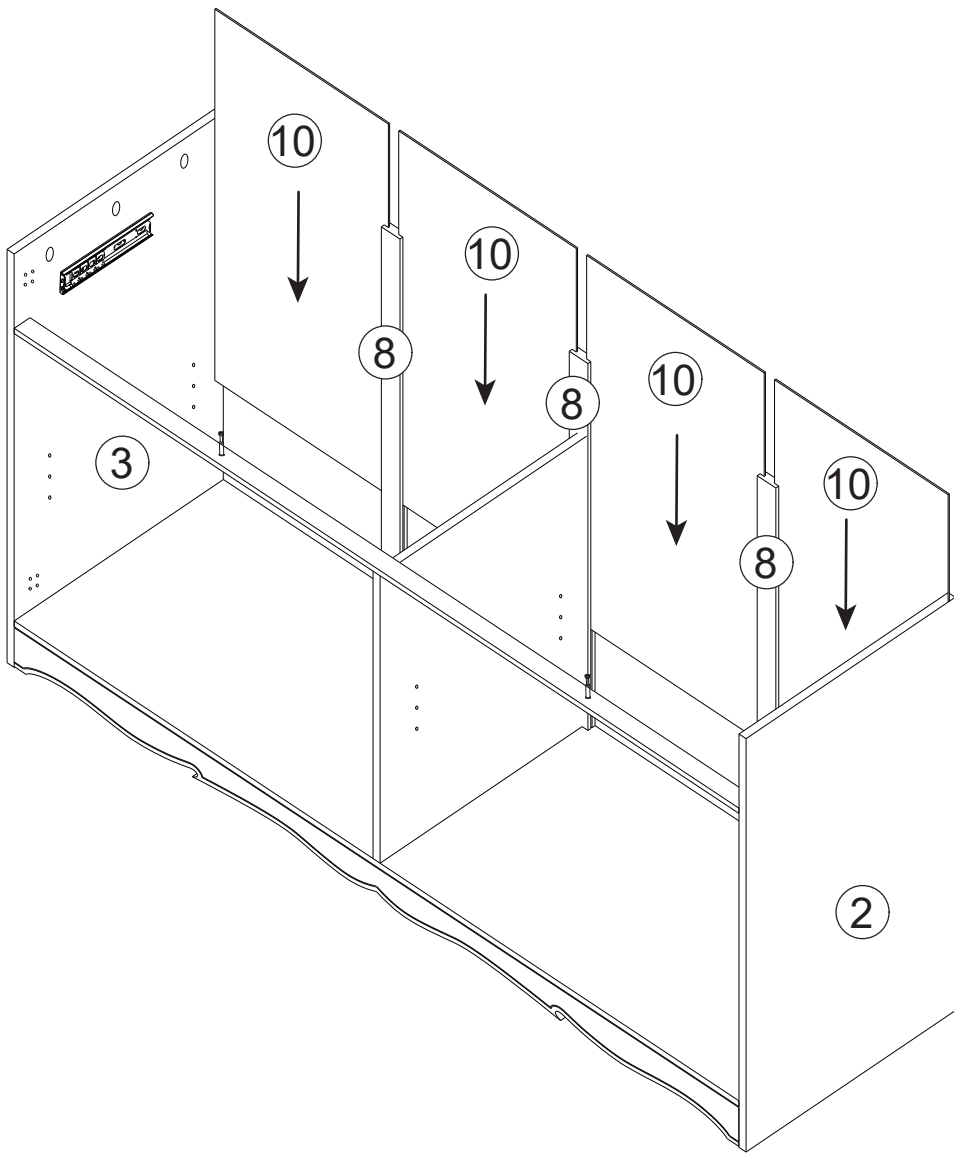

8

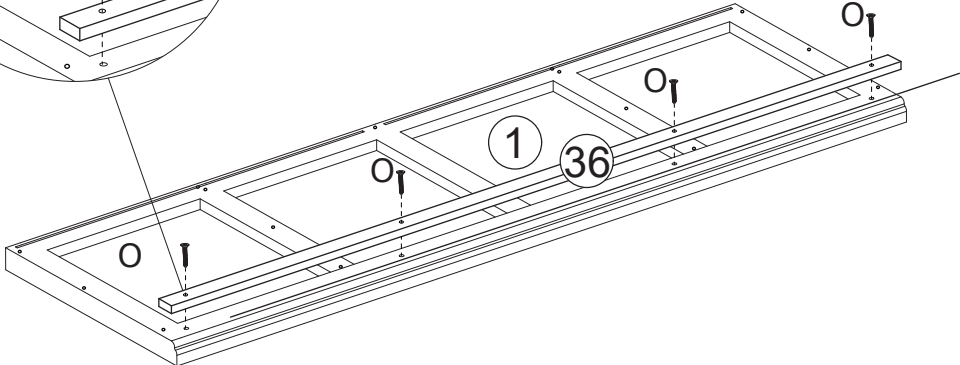
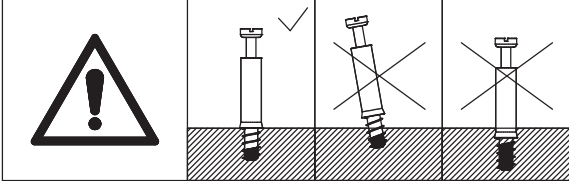
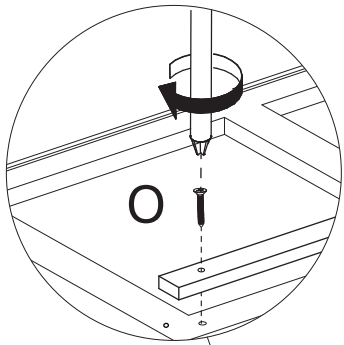
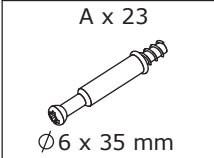

Fix plate 36 to plate 1 using screw(O) as shown. Insert quickfit screw(A) into corresponding holes in plate 1 with a screwdriver as shown. Flip the plate, and insert quickfit screw(A) as well.

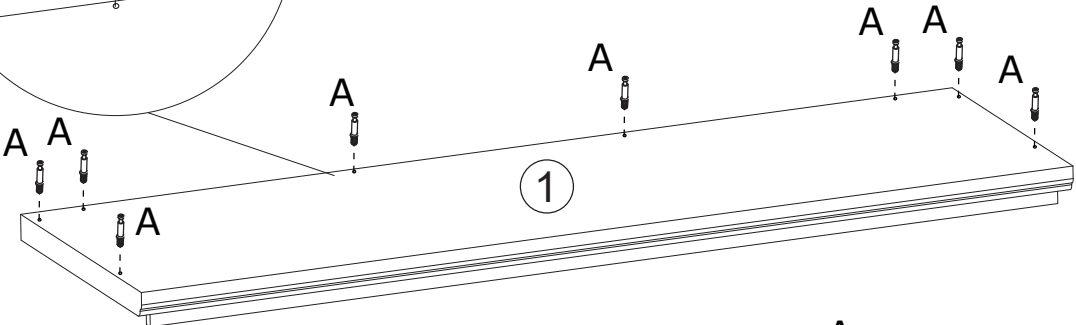
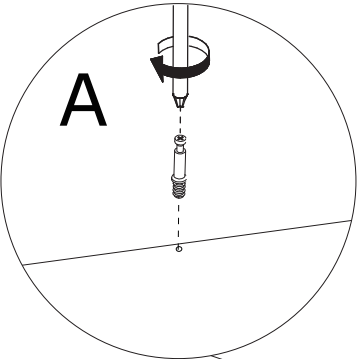

180°

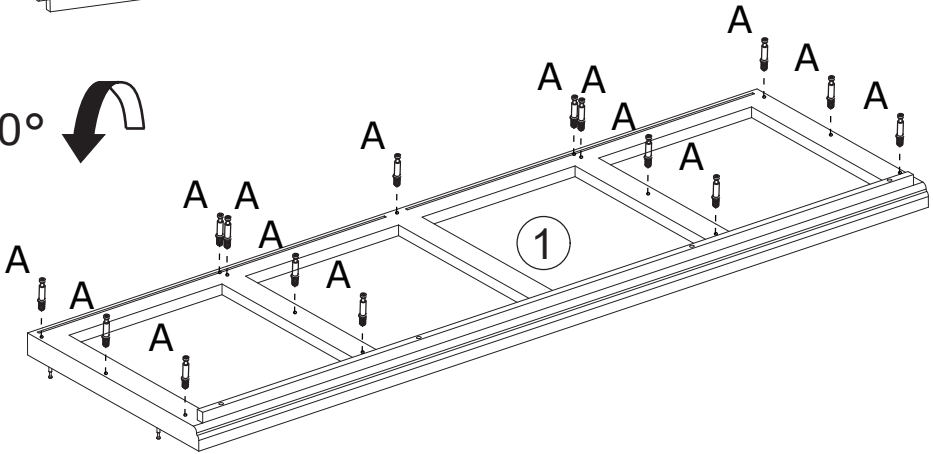

9

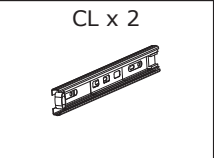
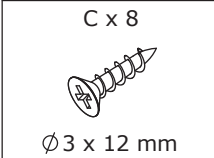

Fix slide rail(CL) to plate 7(x2) using screw(C) as shown.

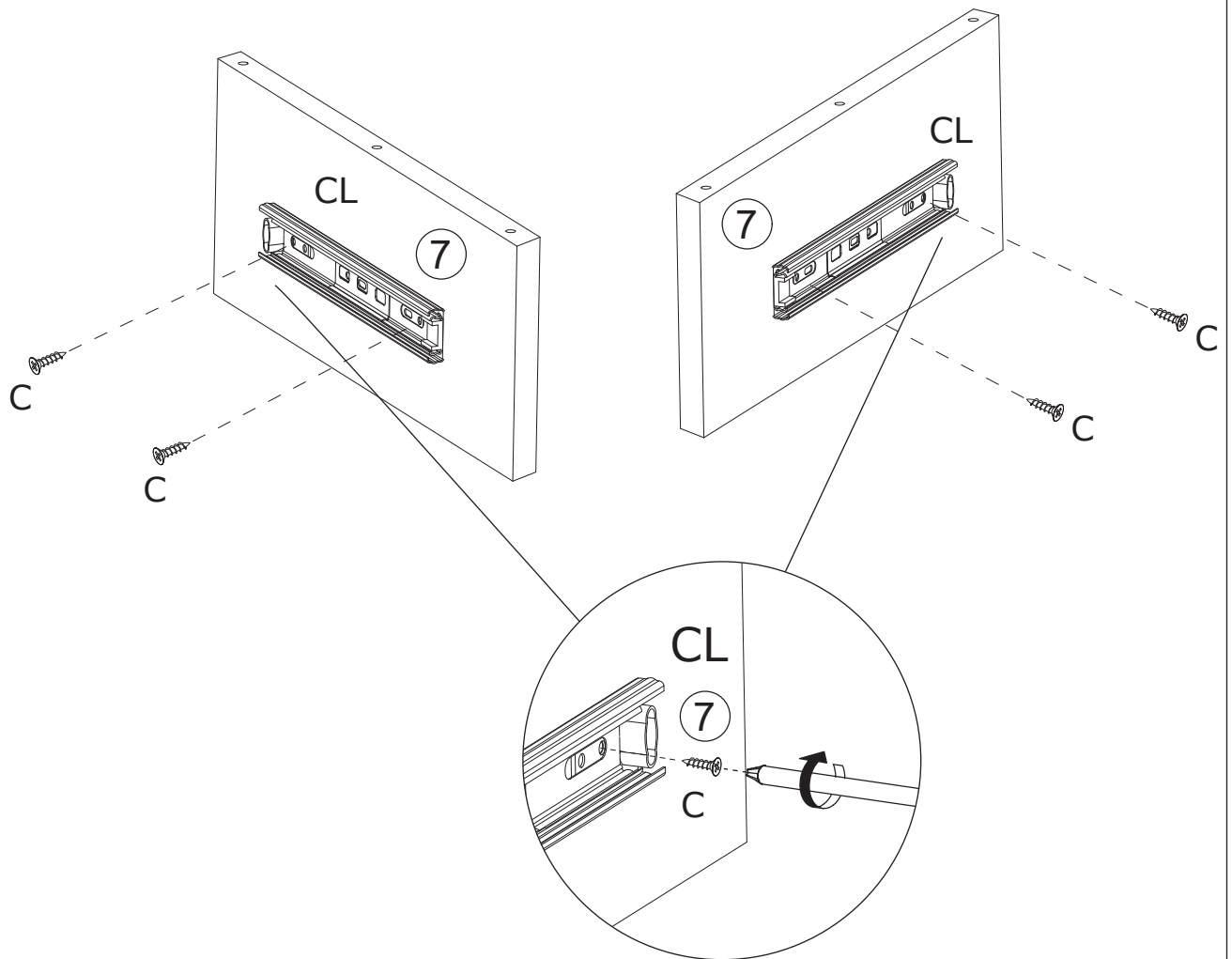

x2

10

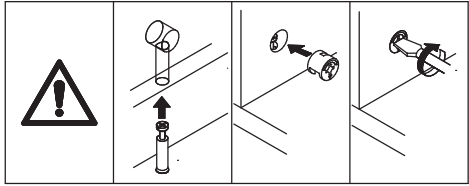
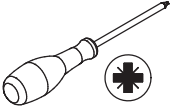
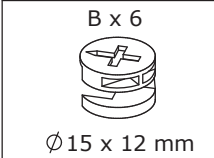

Attach plate 7 to plate 1, insert cam lock (B) into holes in plate 7 and turn clockwise to tighten as shown.

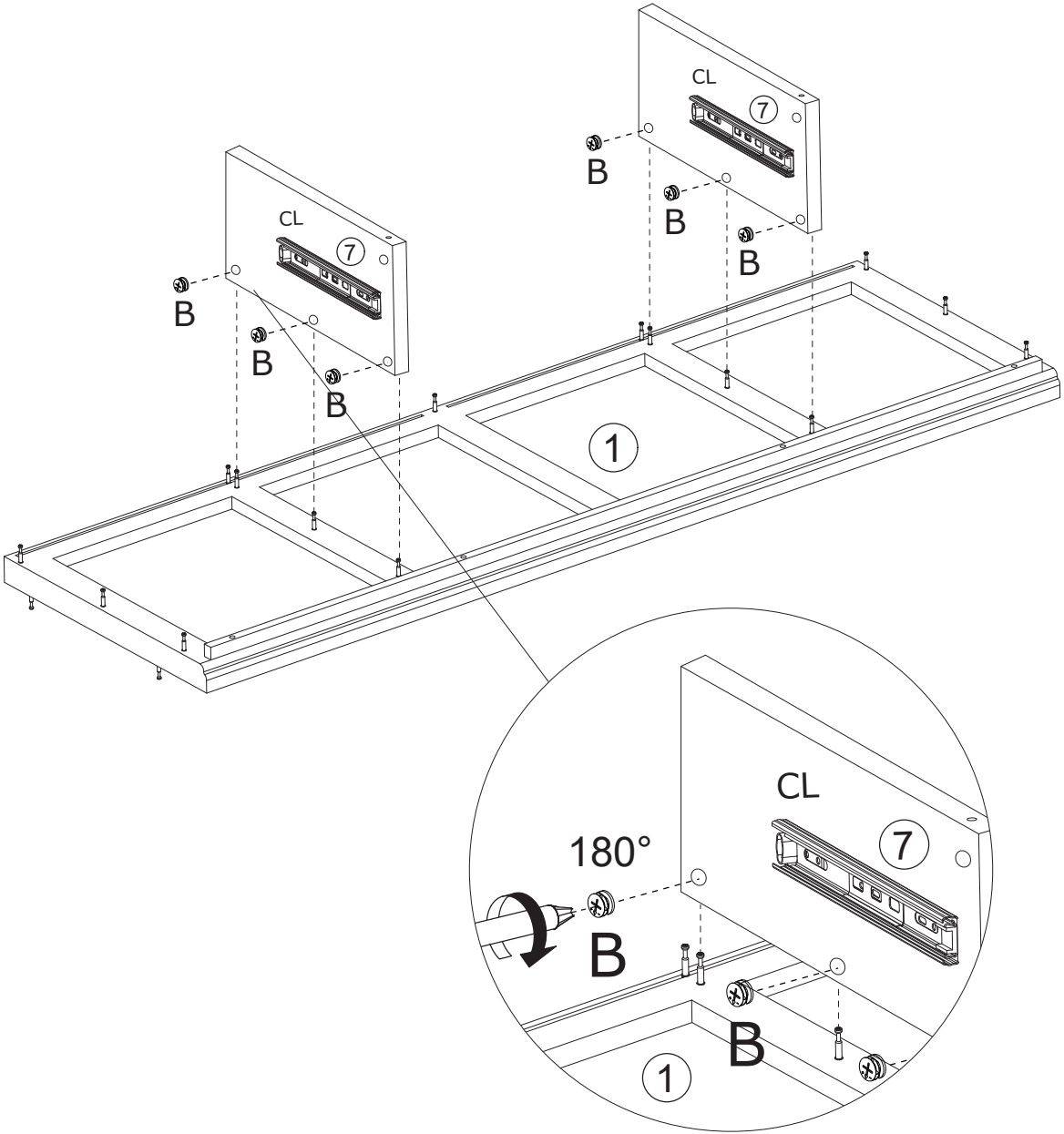

11

B x 11
Ø 15 x 12 mm

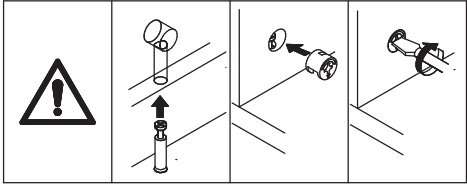
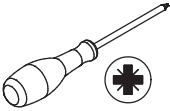

Cover plate 1 to the top of the component,
insert cam lock(B) into holes in plate 3,7,2,8
and turn clockwise to tighten as shown.

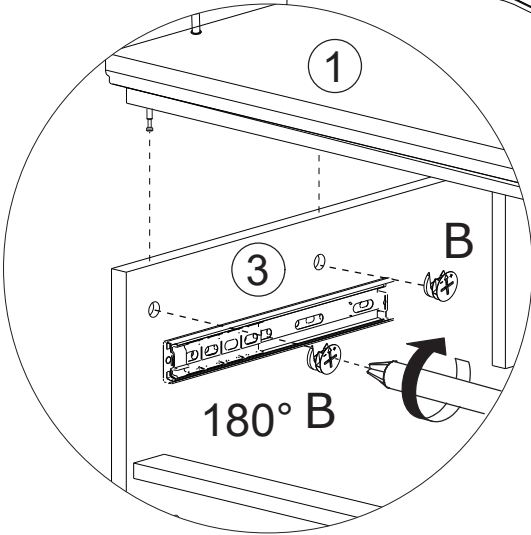
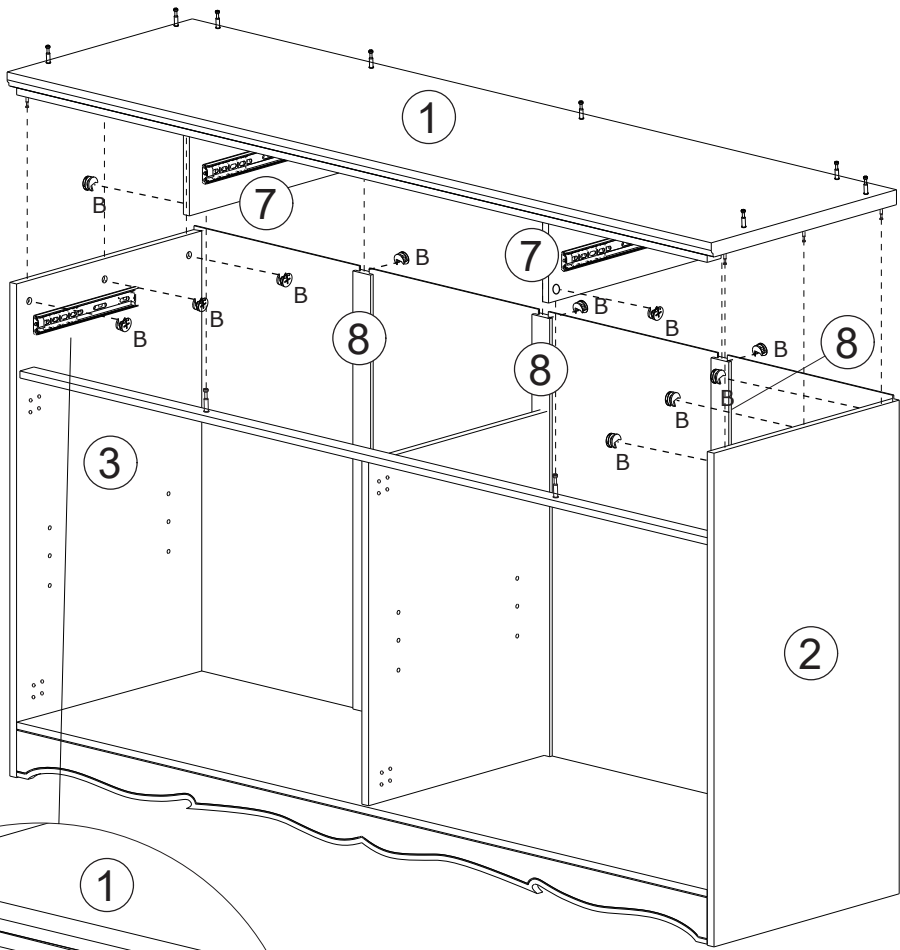

12

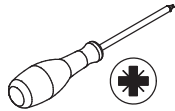
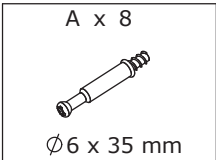

Insert quickfit screw(A) into corresponding holes in plate 22 with a screwdriver as shown.
Flip the plate, and insert quickfit screw(A) as well.

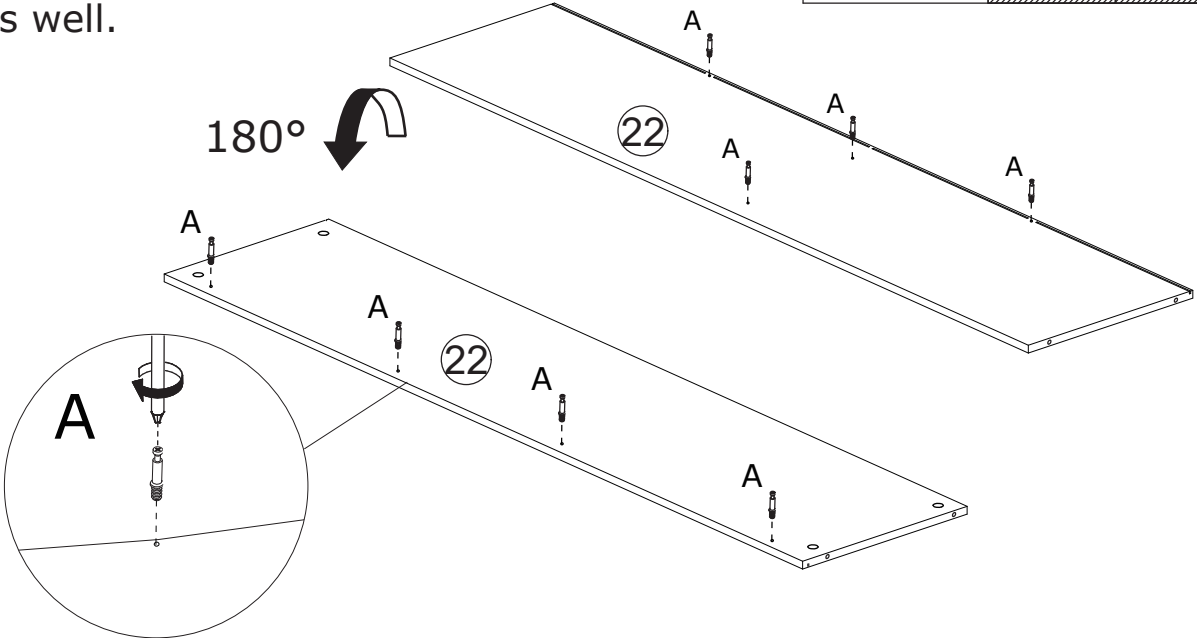
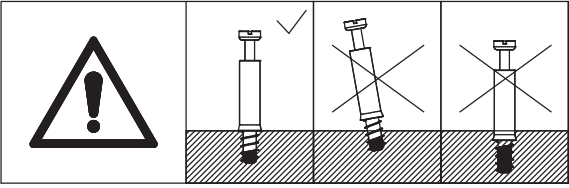

13

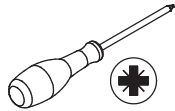
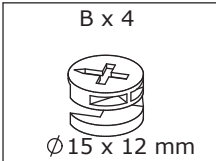

Connect plate 22 with plate 21, insert cam lock(B) into holes in plate 21 and turn clockwise to tighten as shown.

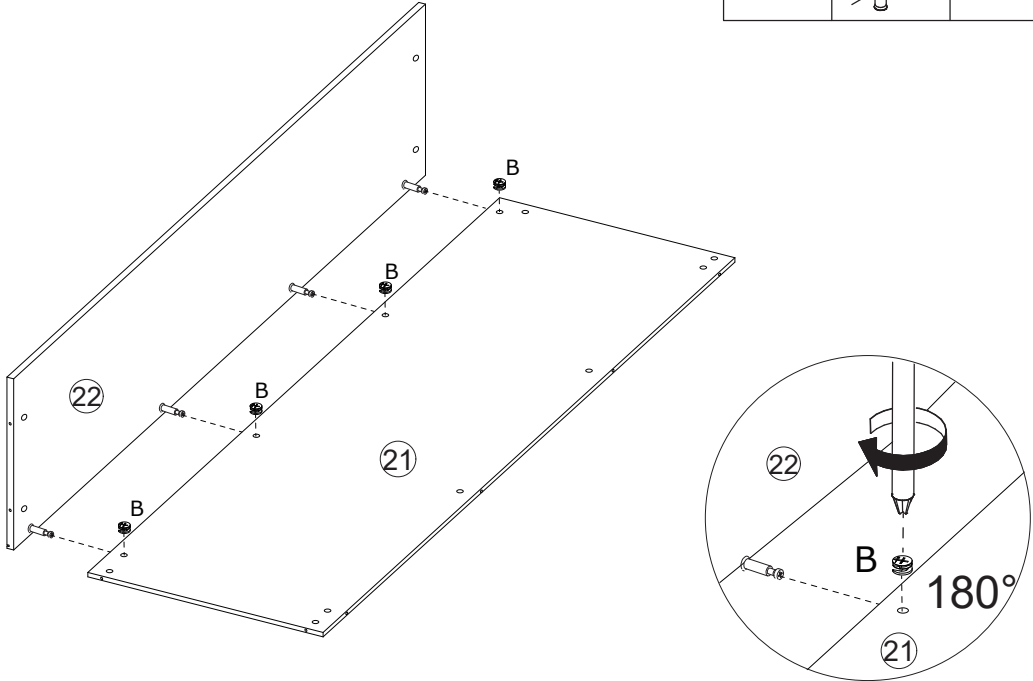
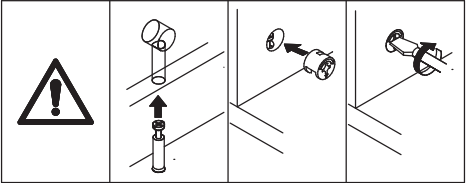

A x 8

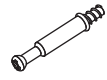

Ø6 x 35 mm

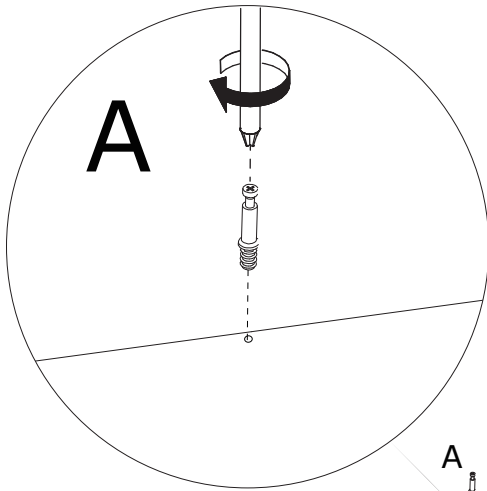
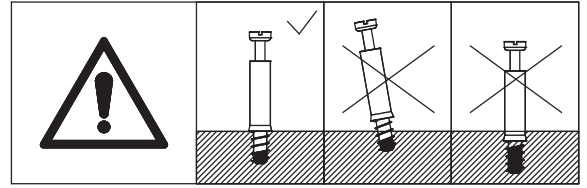

Insert quickfit screw(A) into corresponding holes in plate 19 and 20 with a screwdriver as shown.

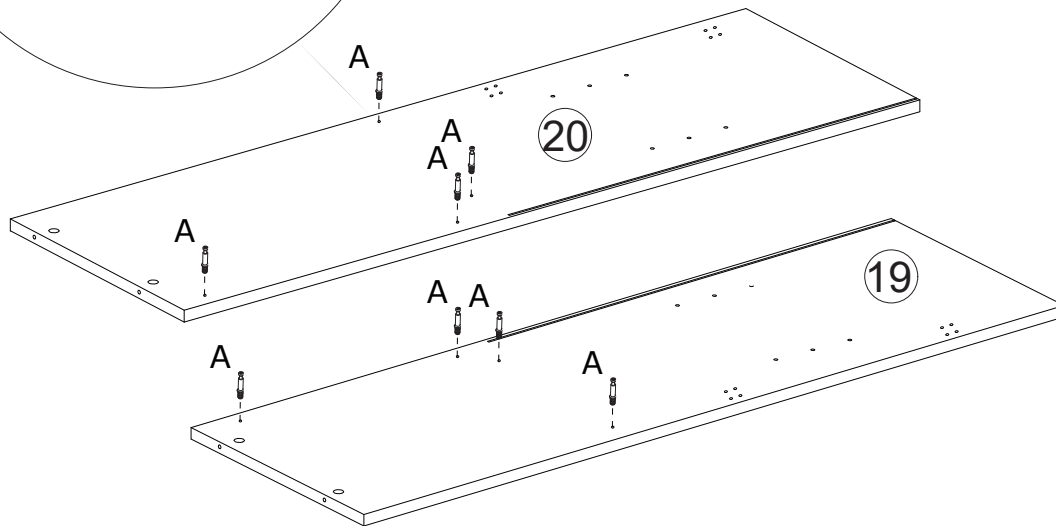

15

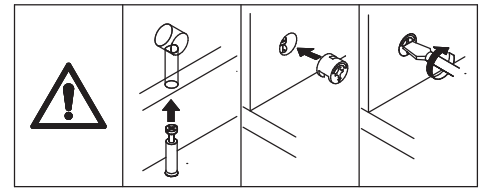
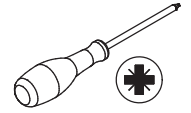
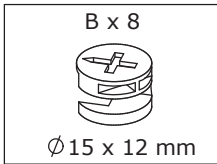

Connect plate 19 and 20 with plate 21 and 22, insert cam lock(B) into holes in plate 21,22 and turn clockwise to tighten as shown.

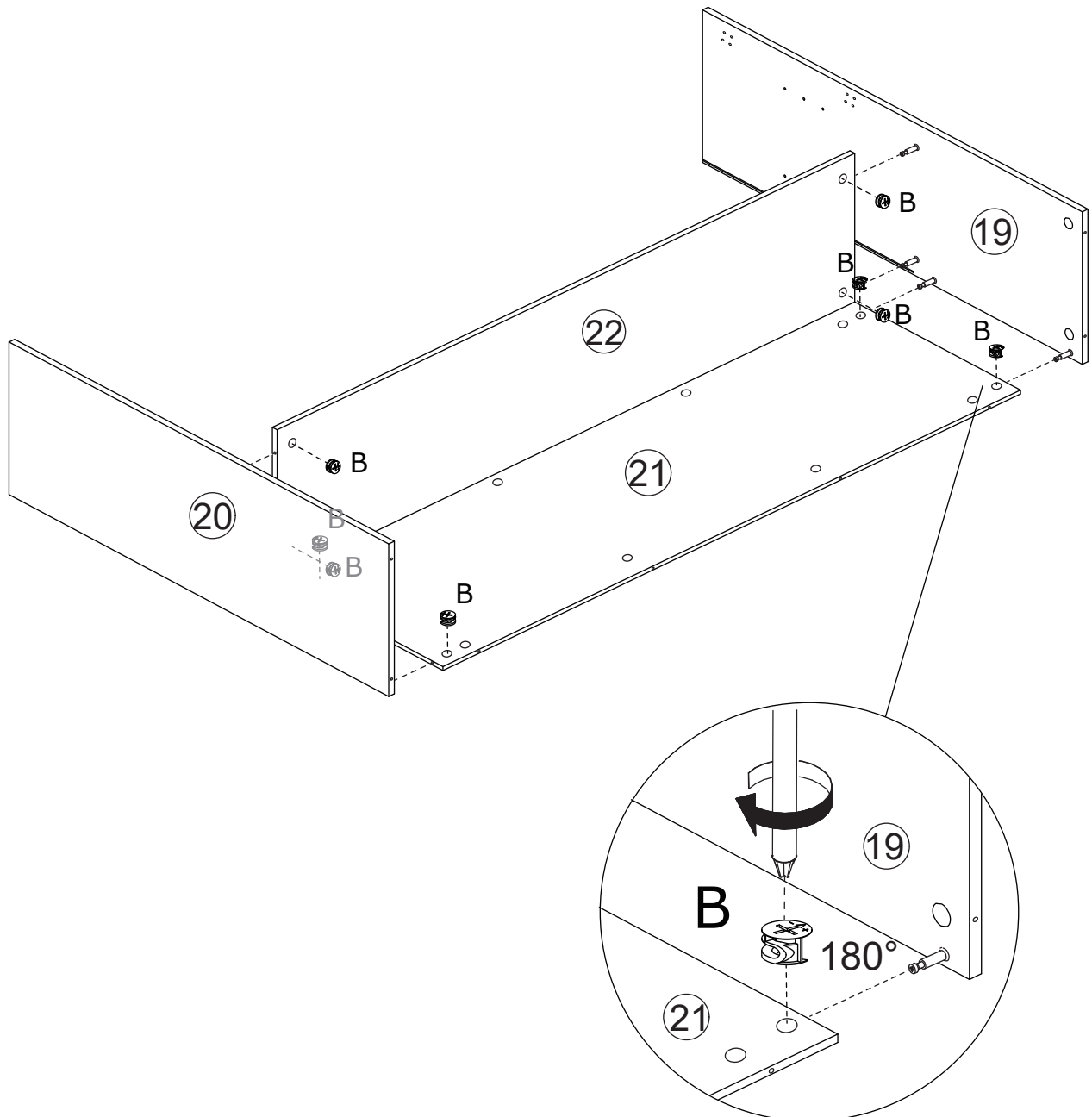

16

B x 4
Ø 15 x 12 mm

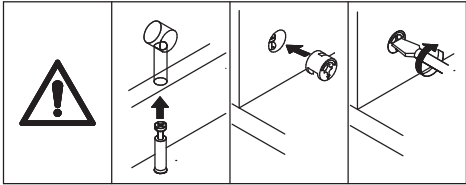
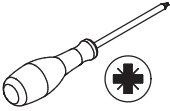

Attach plate 23 and 24(x2) to plate 22,
insert cam lock(B) into holes in plate 23,24
and turn clockwise to tighten as shown.

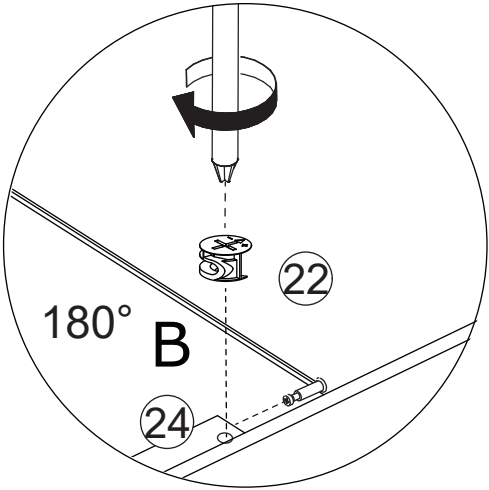
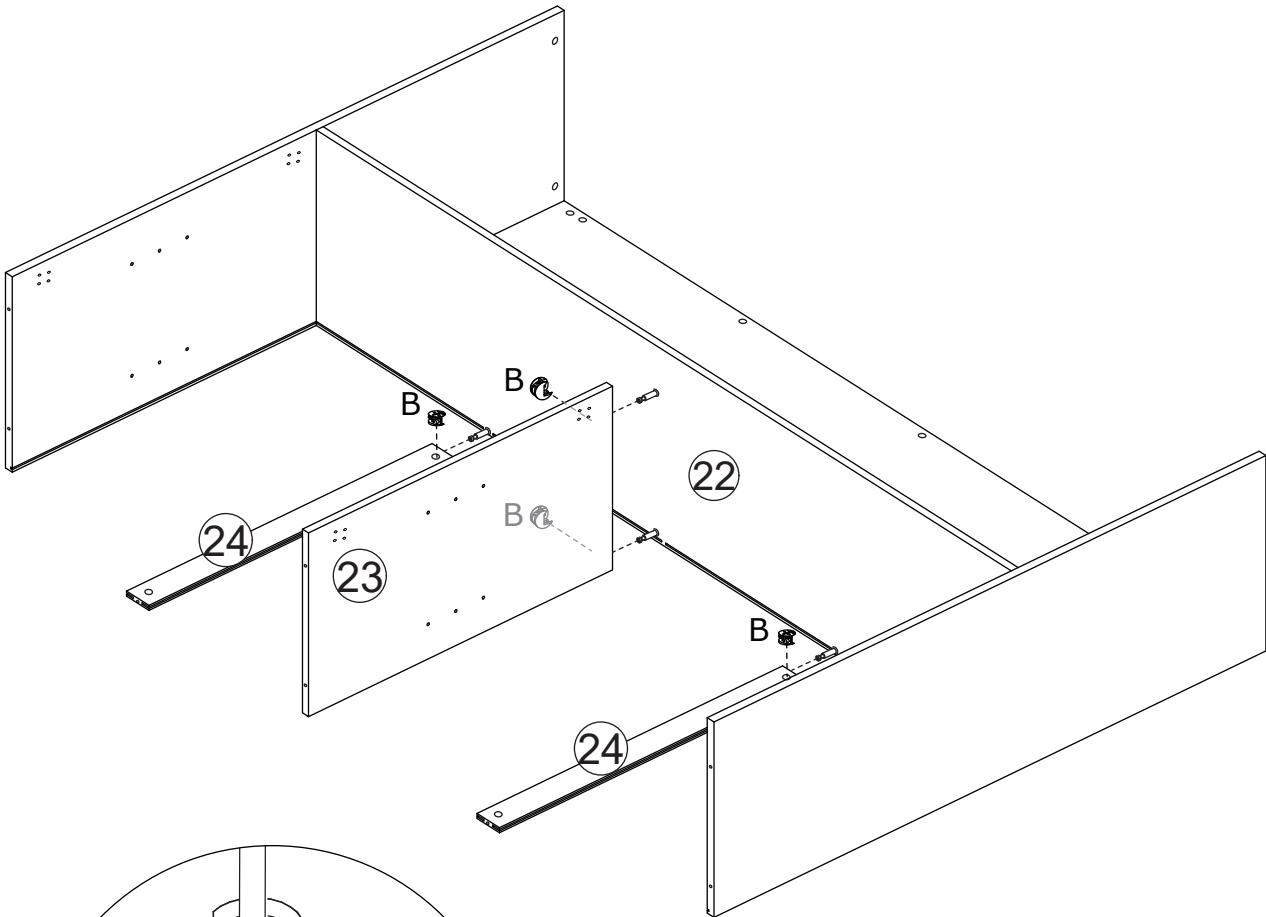

17

Slide plate 26 into available slots as shown.

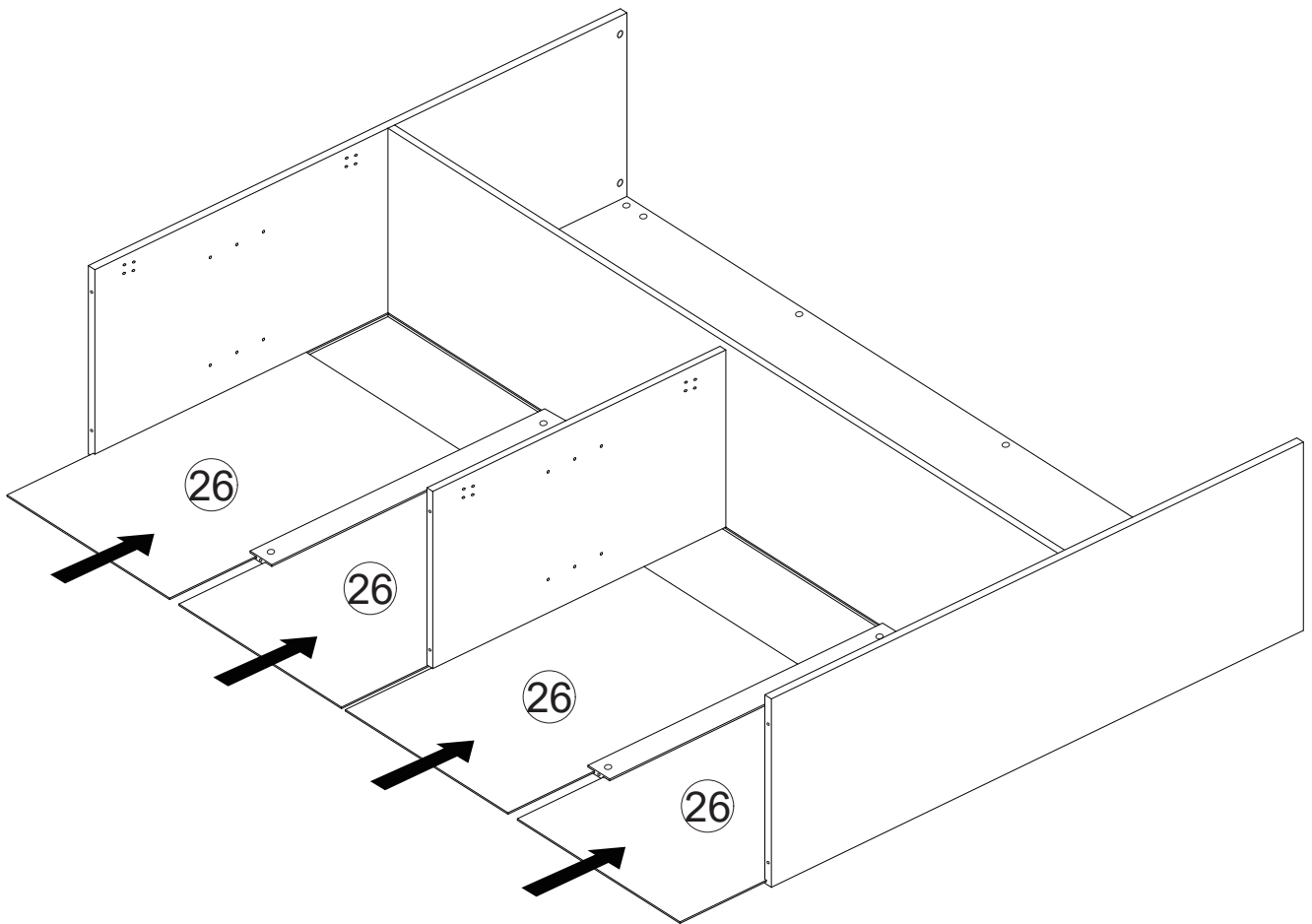

18

O x 4

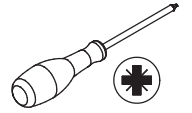

Fix plate 35 to plate 18 using screw(O) as shown.

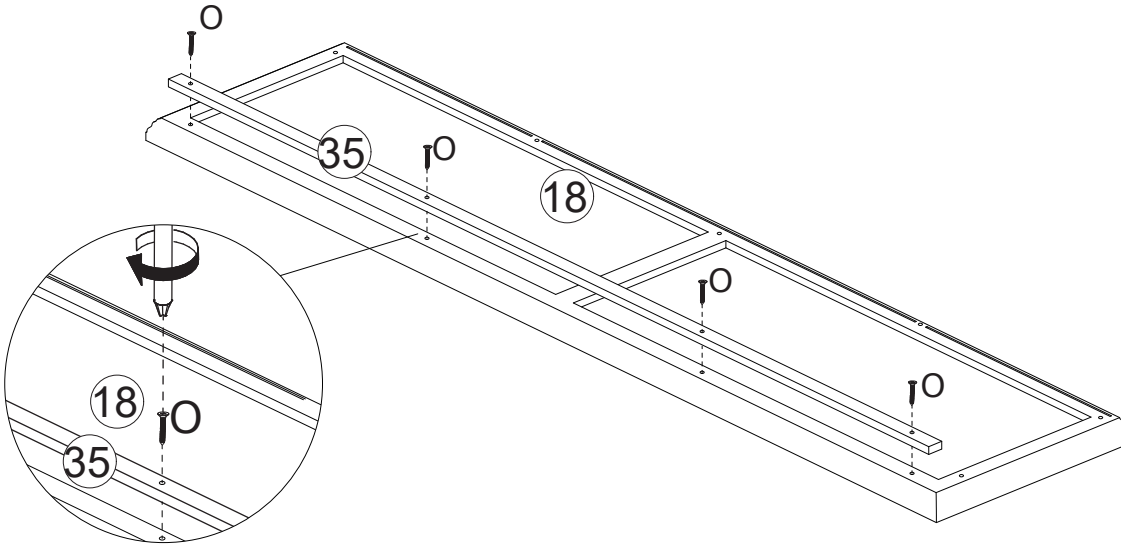

19

A x 8

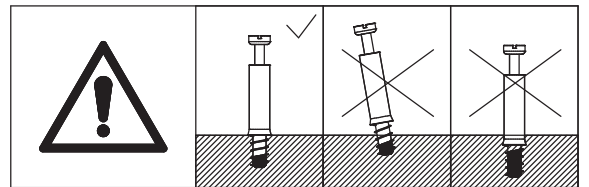
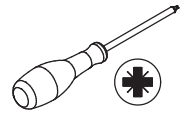
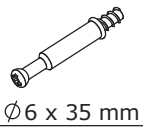

Insert quickfit screw(A) into corresponding holes in plate 18 with a screwdriver as shown.

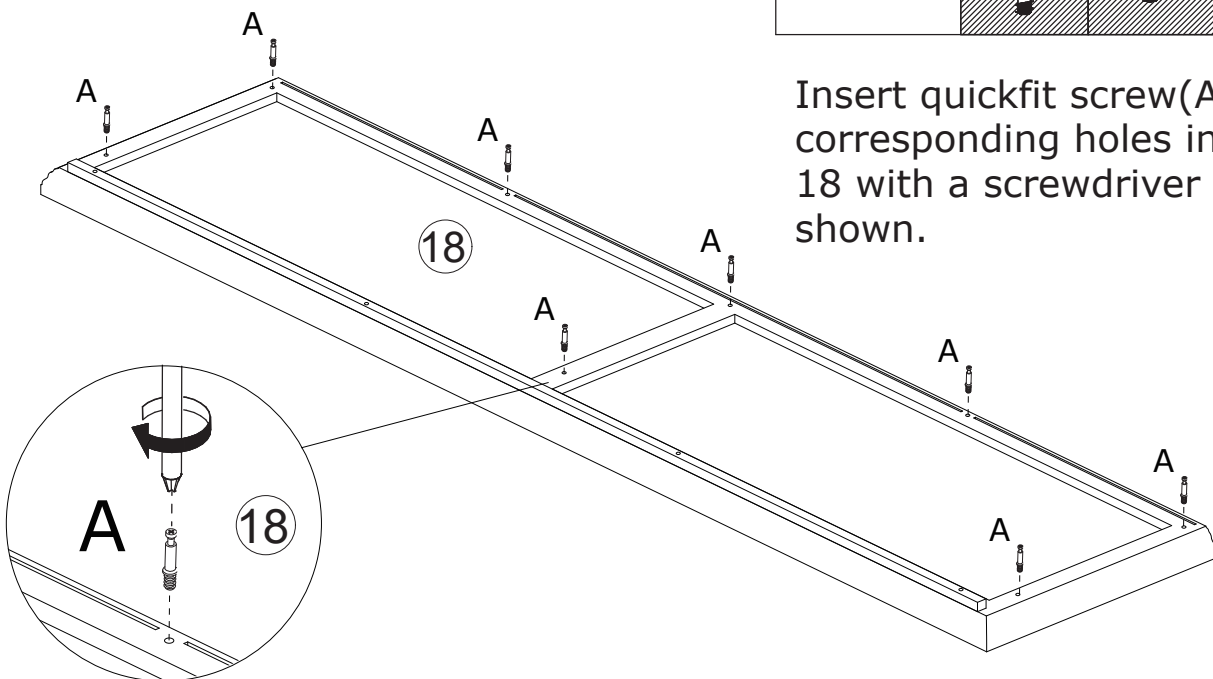

20

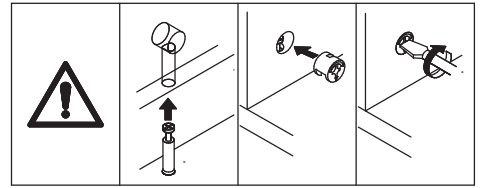
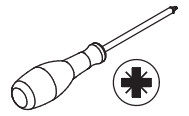
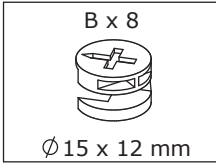

Cover plate 18 to plate 19,23,20 and 24,
insert cam lock(B) into holes in plate 19,
23,20,24 and turn clockwise to tighten
as shown.

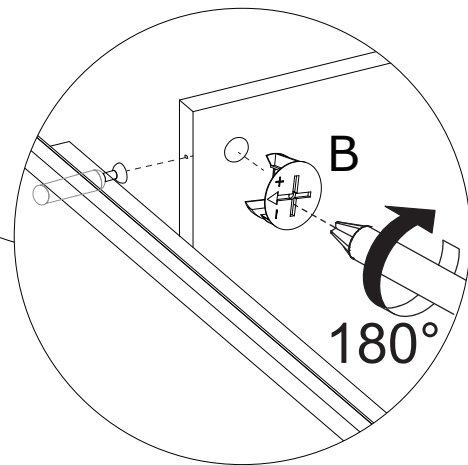
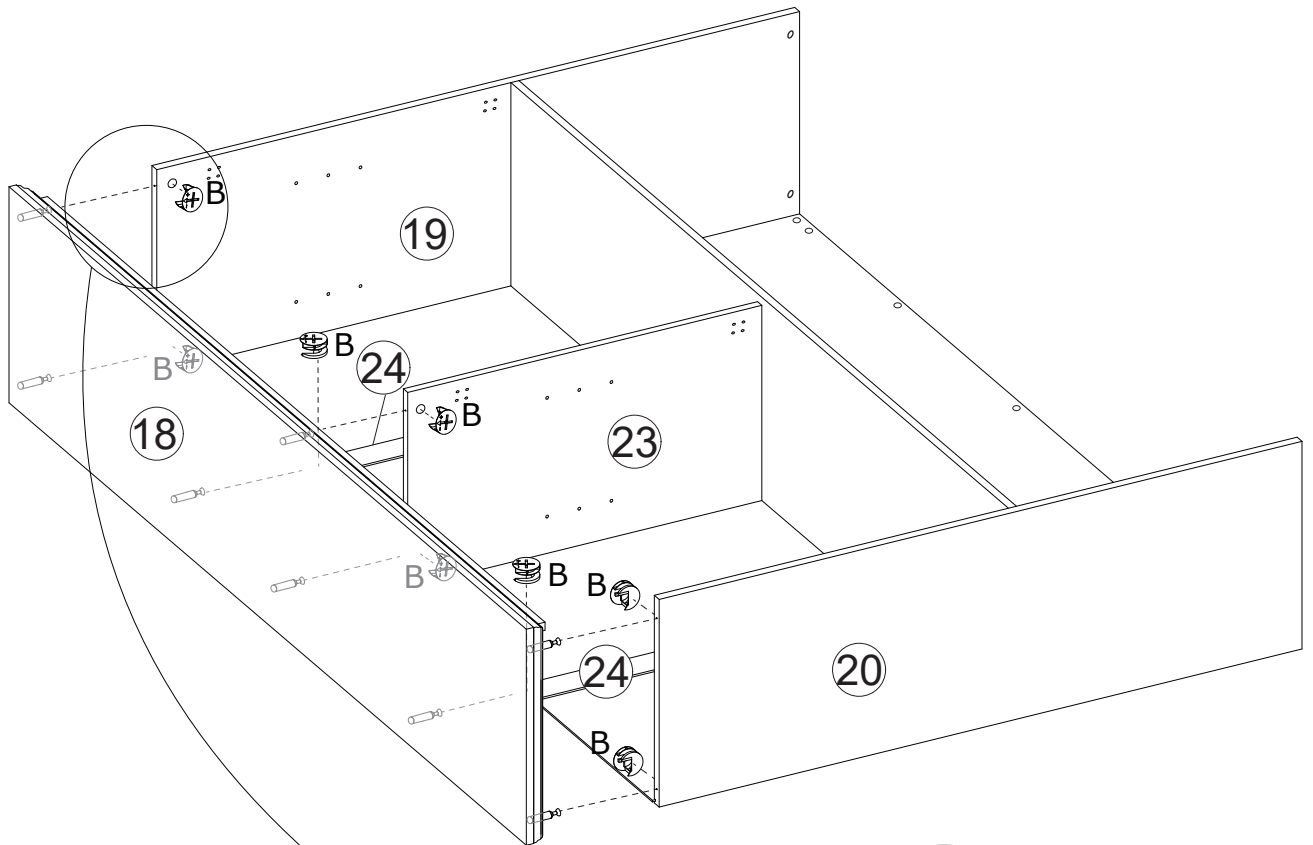

21

B x 8
Ø 15 x 12 mm

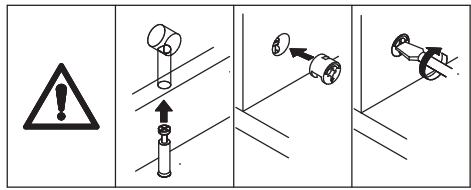
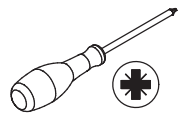

Connect two assembled components, insert cam lock(B) into holes in plate 19,20,21 and turn clockwise to tighten as shown.

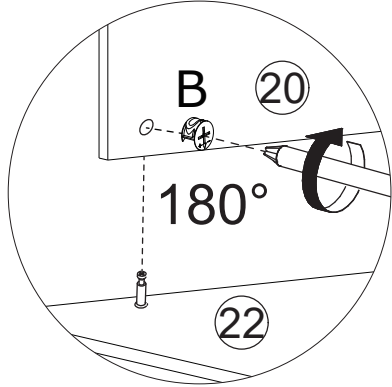
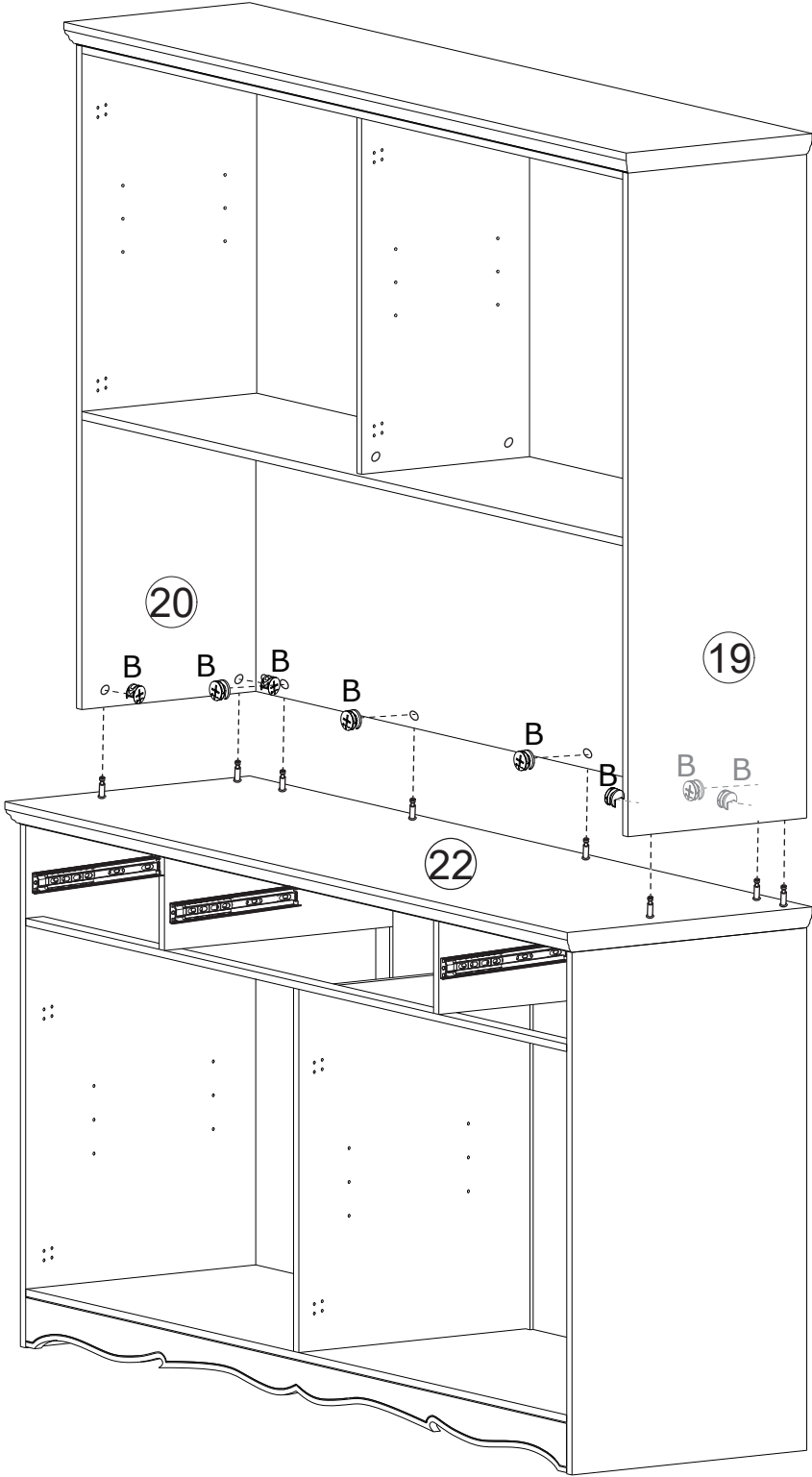

22

H x 16



Insert part(H) into the holes in plate 19,23,20,2,5 and 3 at first.

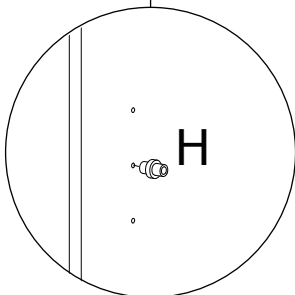
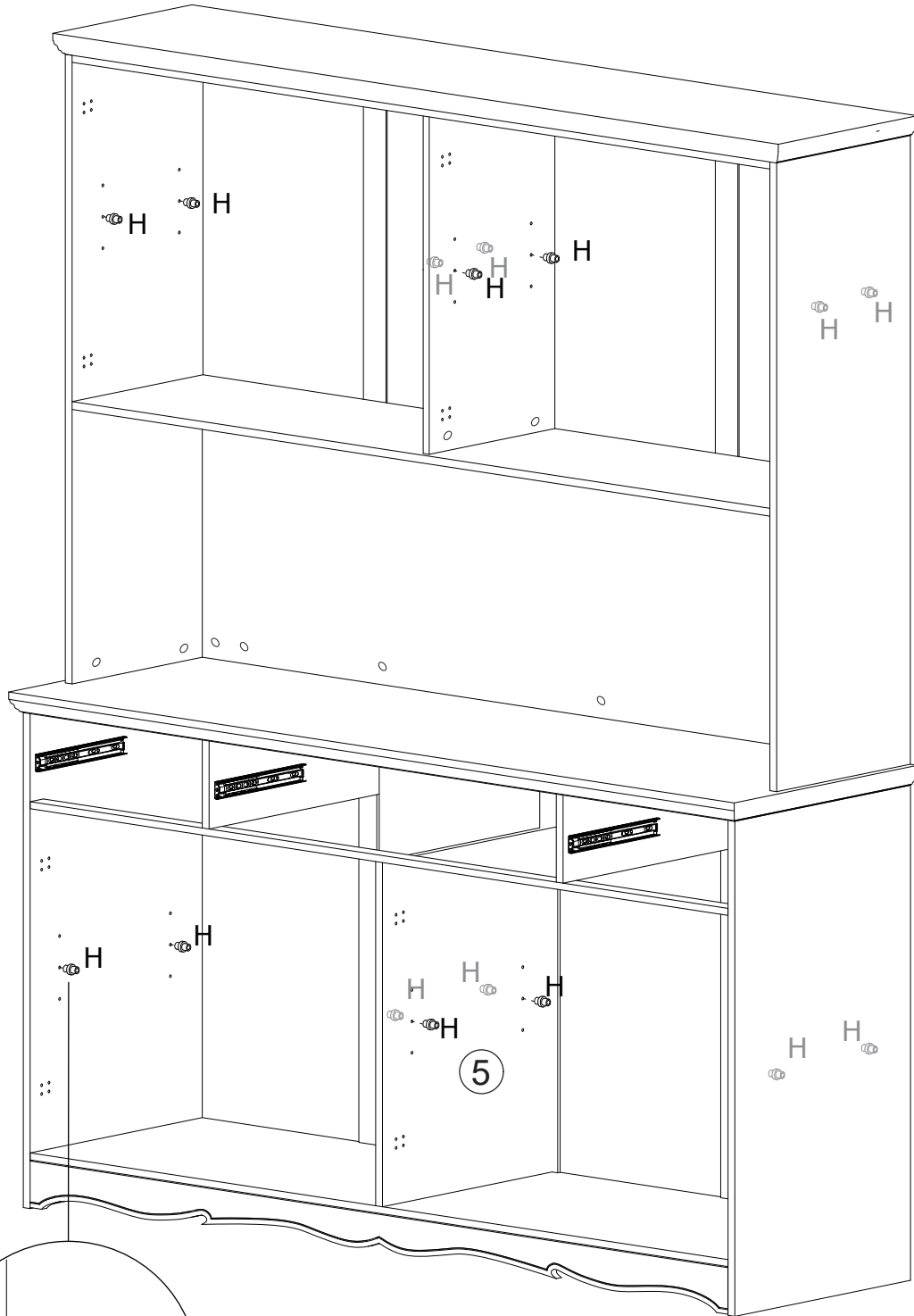

23

Place shelf 32 and 33 into corresponding position as shown.

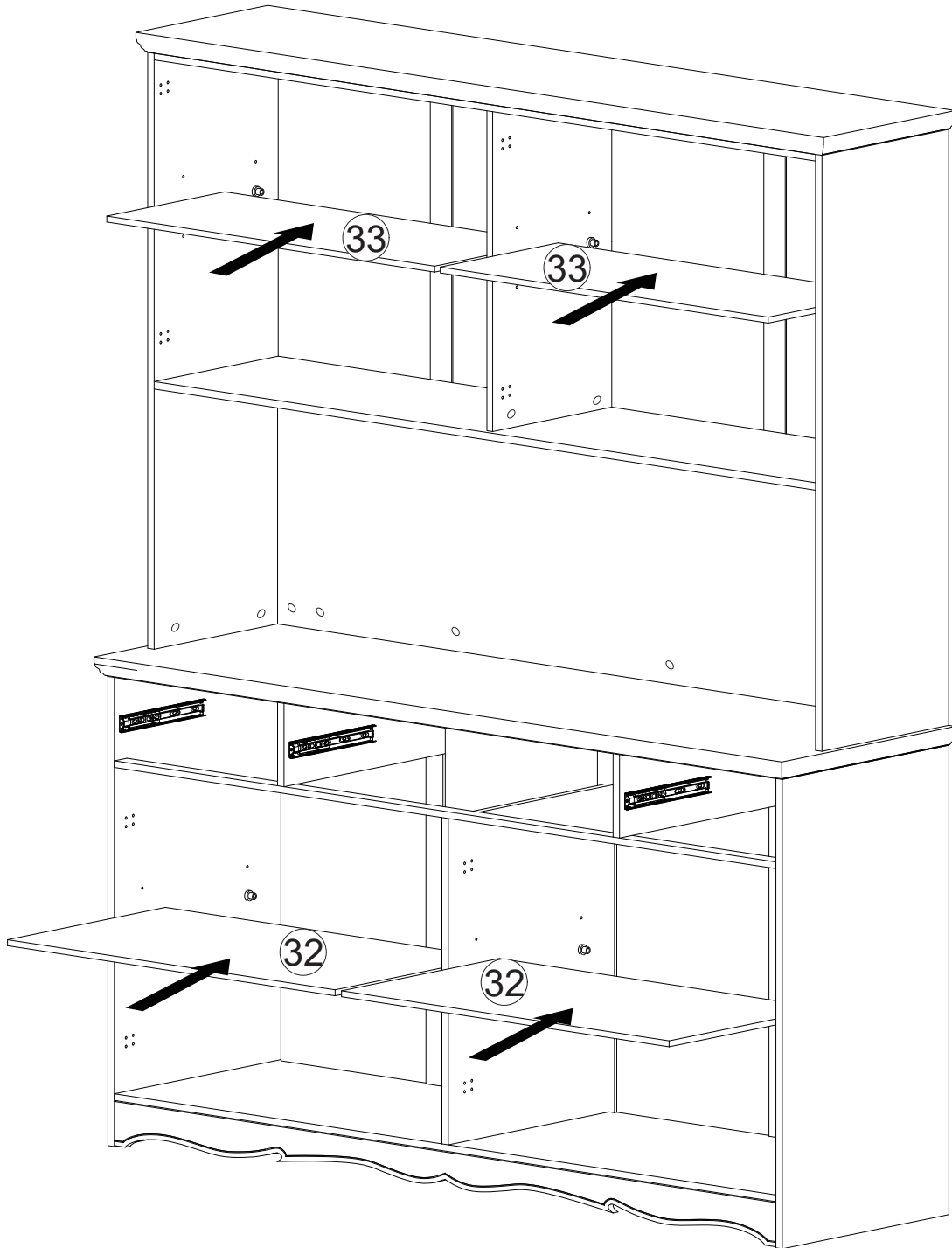

24

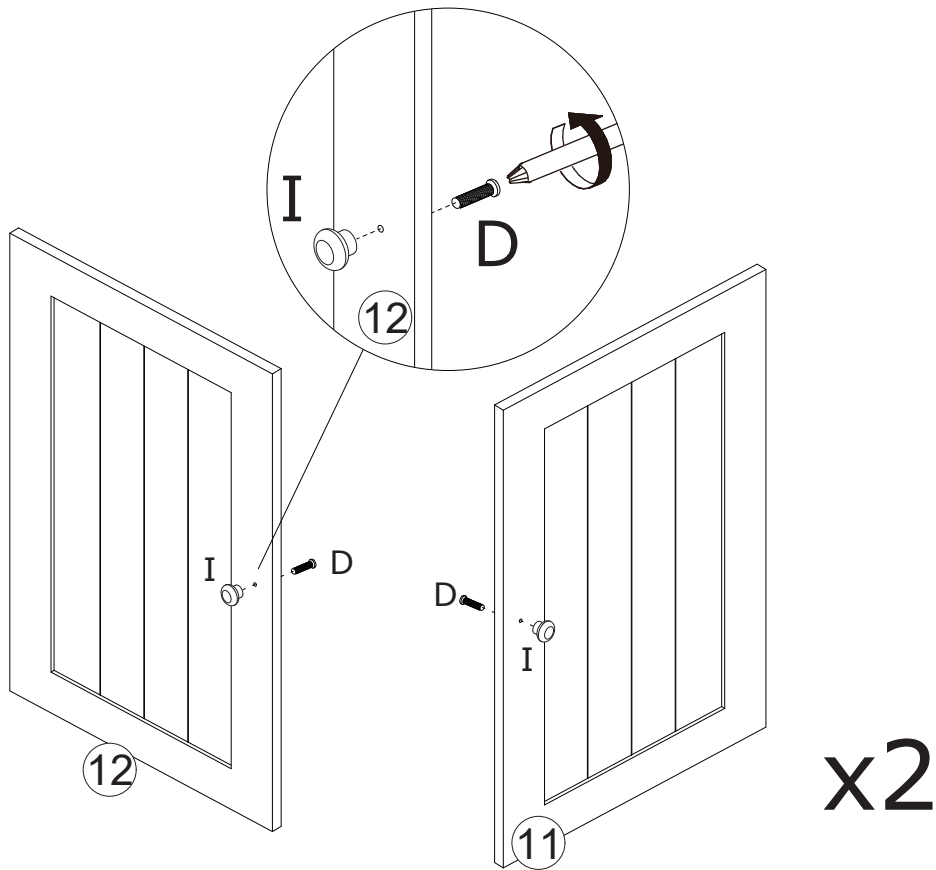
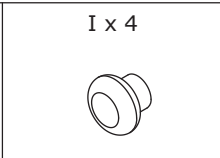
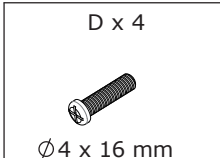

Fix knob(I) to plate 11 and 12 using screw(D) as shown.

25

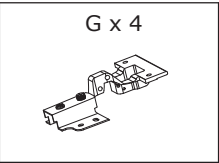
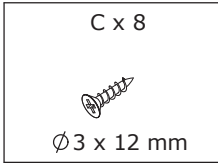

Fix hinge(G) to plate 11 and 12 respectively using screw(C) as shown.

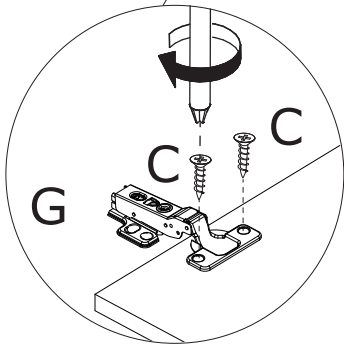
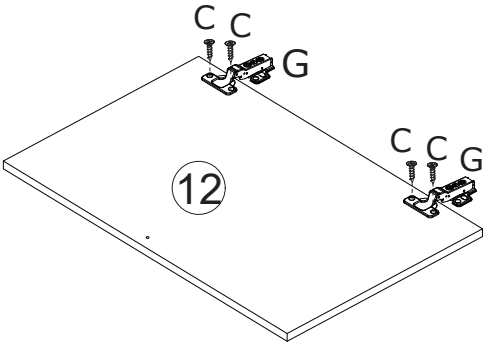
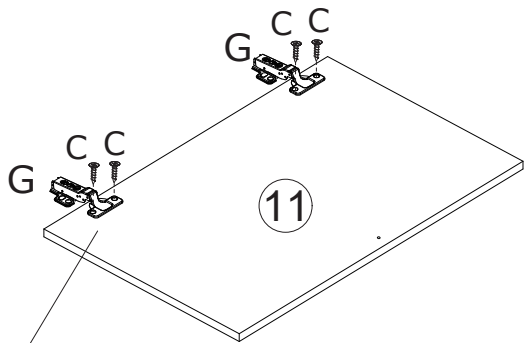

26

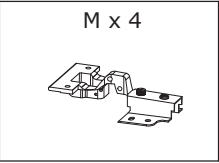
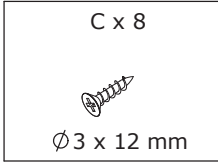

Fix hinge(M) to another plate 11 and 12 respectively using screw(C) as shown.

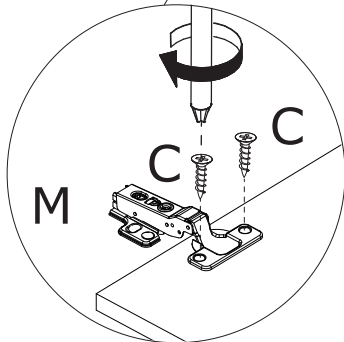
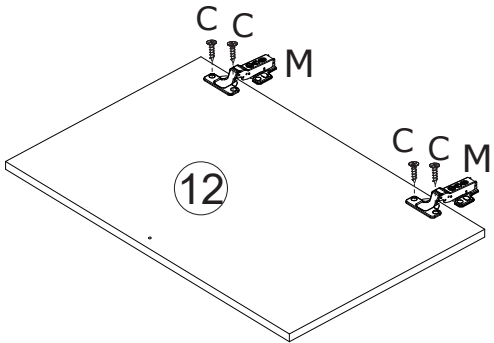
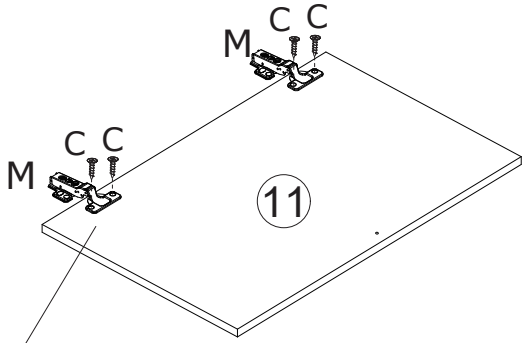

27

C x 32

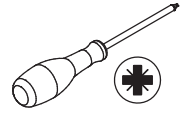
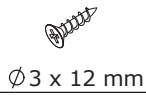

Attach door plate 12 to plate 3 and 5;
door plate 11 to plate 2 and 5 by fixing
hinge with screw(C) as shown.

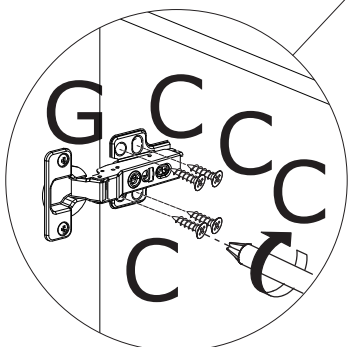
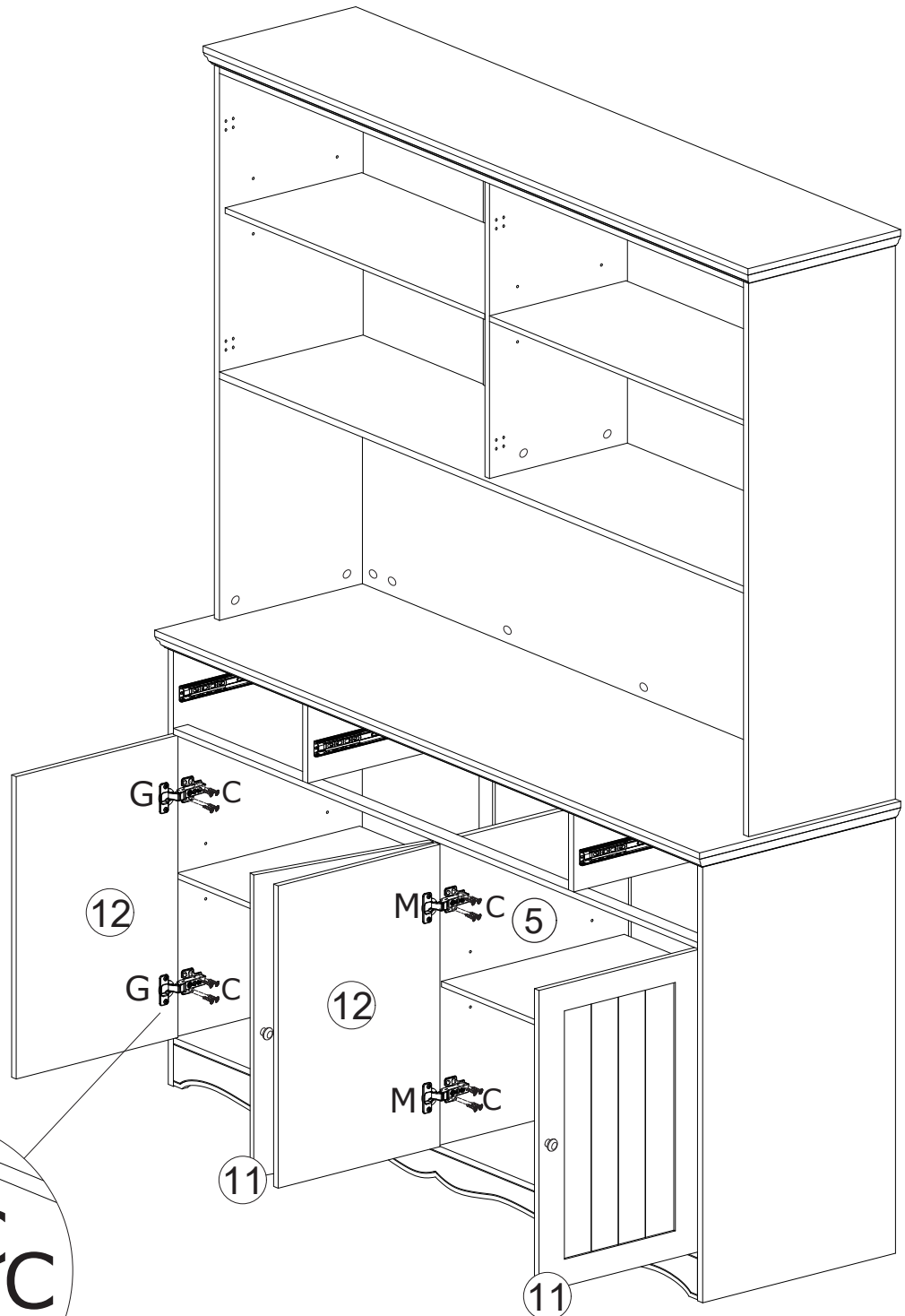

28

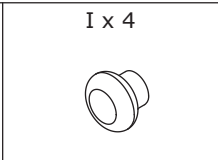
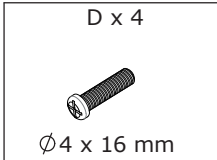

Fix knob(I) to plate 27 and 28 using screw(D) as shown.

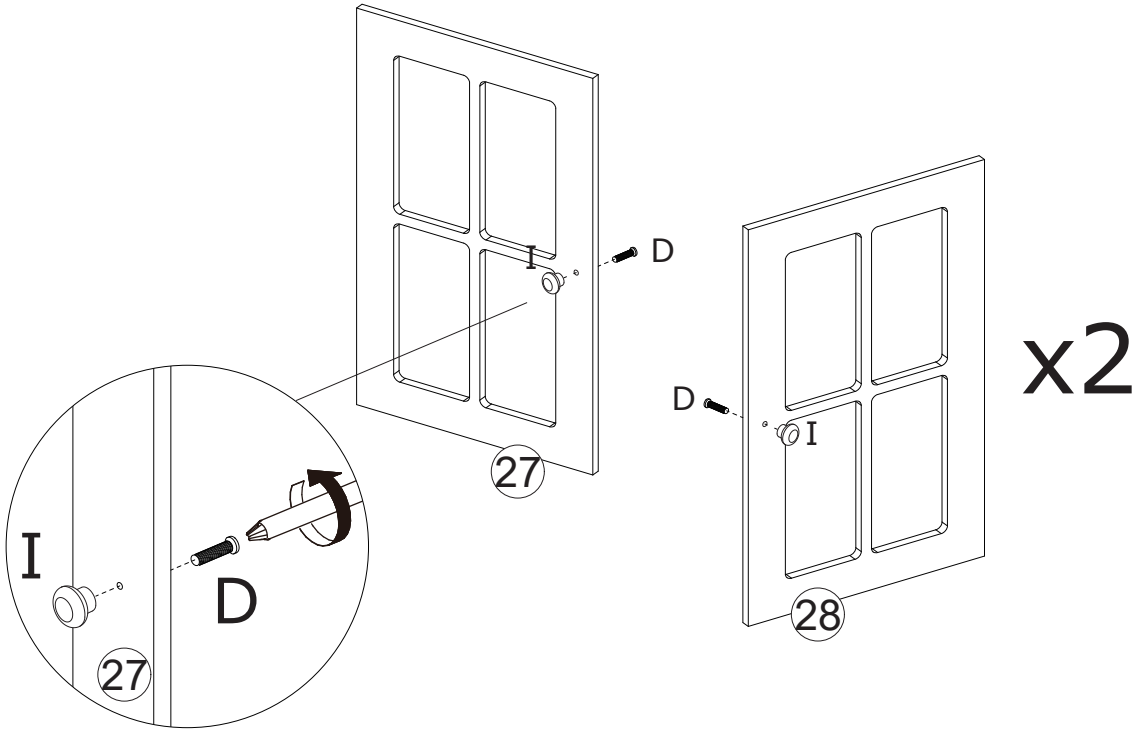

29

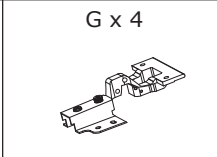
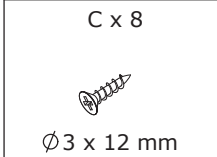

Fix hinge(G) to plate 27 and 28 respectively using screw(C) as shown.

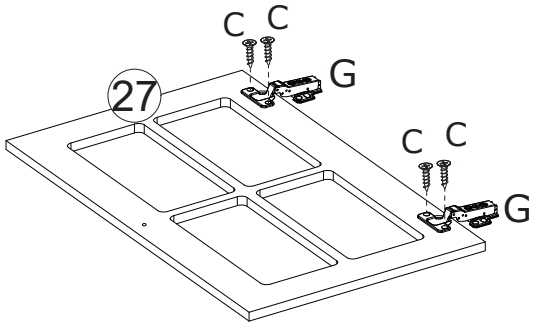
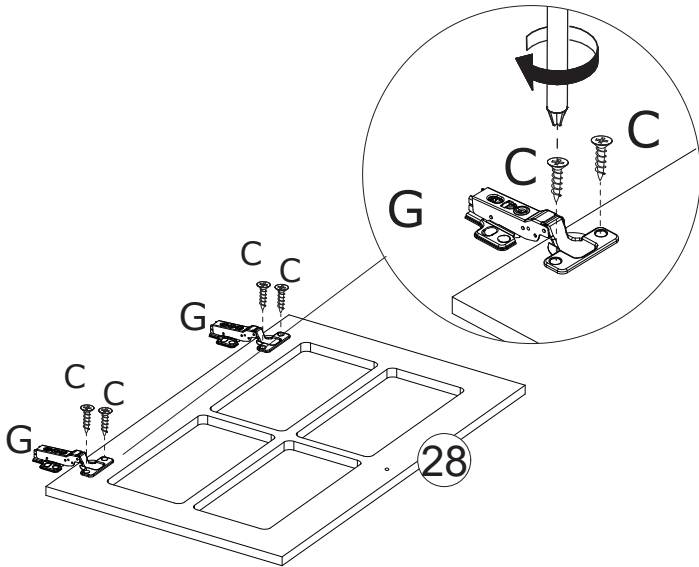

30

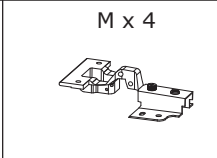
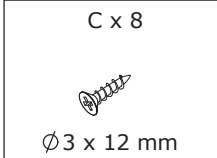

Fix hinge(M) to another plate 27 and 28 respectively using screw(C) as shown.

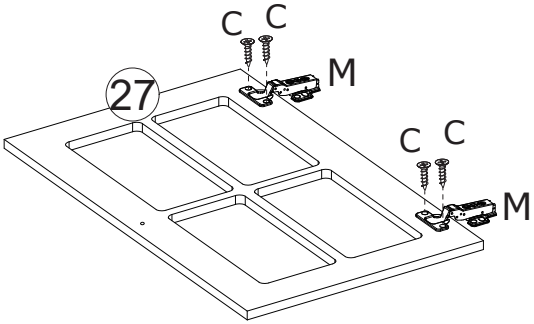
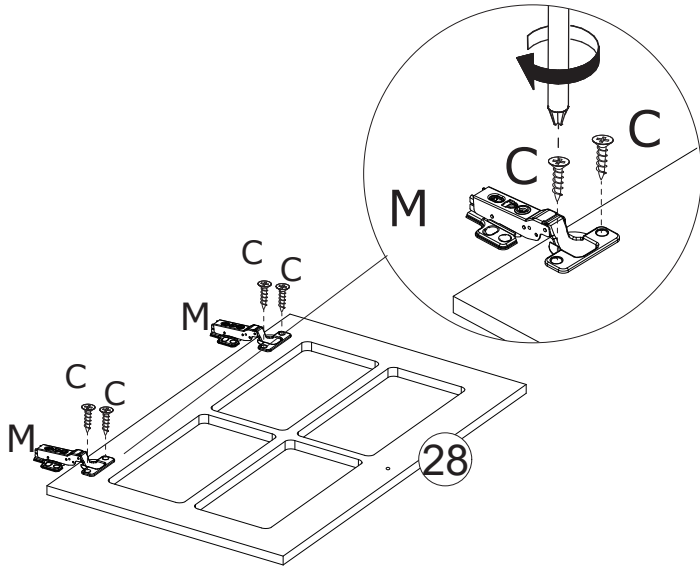

31

C x 32



Ø3 x 12 mm

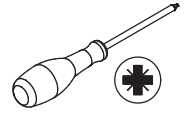

Attach door plate 27 to plate 20 and 23; door plate 28 to plate 23 and 19 by fixing hinge with screw(C) as shown.

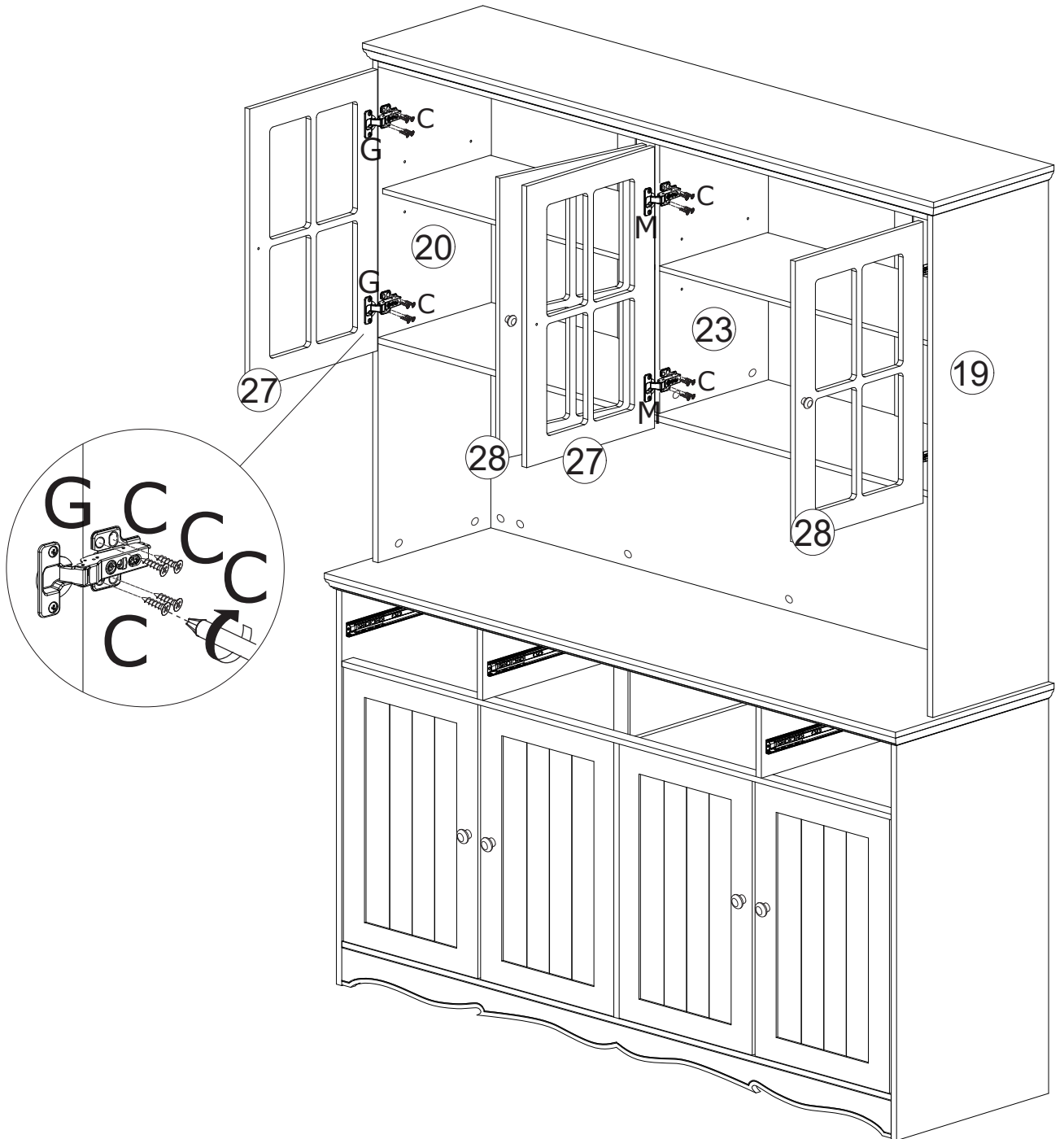

32

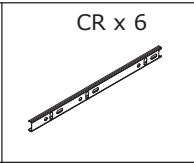
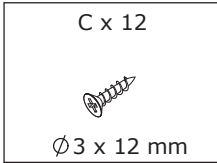

Fix runner(CR) to plate 14 and 15 respectively using sctew(C) as shown.

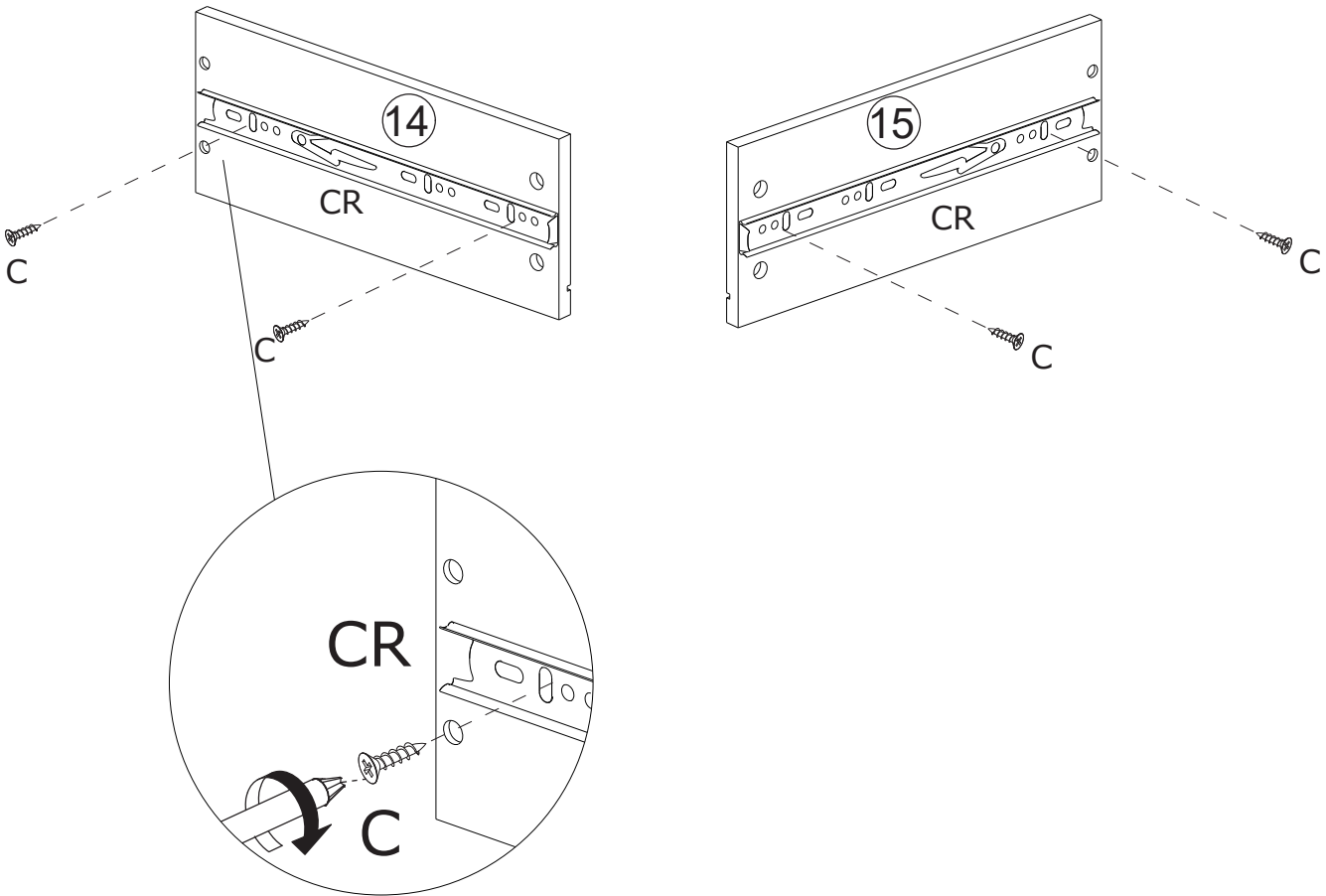

x3

33

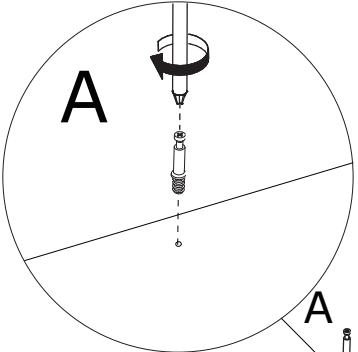
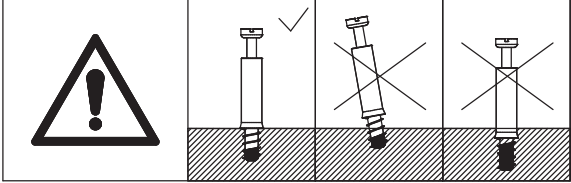
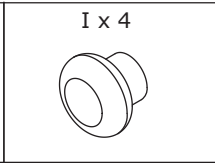
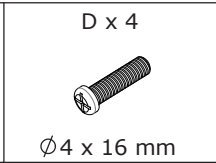
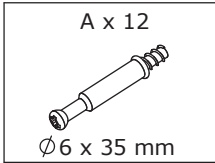

Insert quickfit screw(A) into plate 29 and 13 as shown.

Fix knob(I) to plate 29 and 13 using screw(D) as shown.

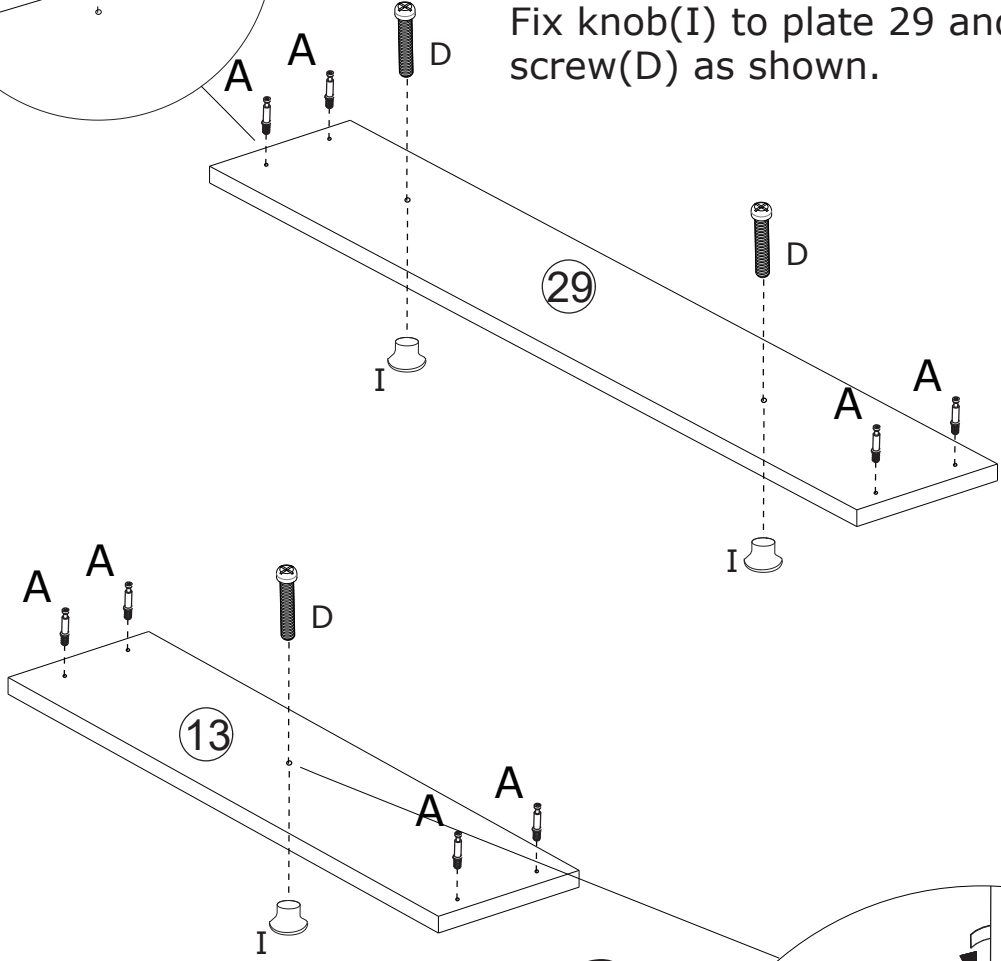

x2

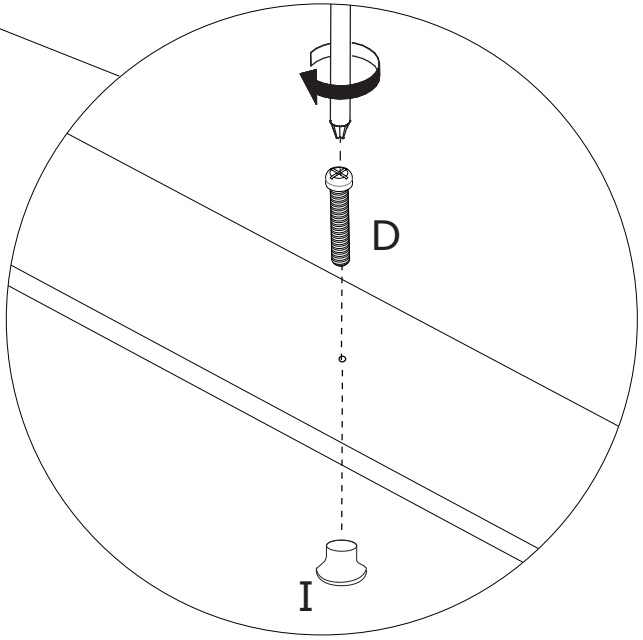

34

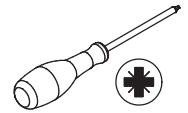

Connect plate 14 and 15 with plate 30 using screw(O) as shown.
Slide plate 31 into available slots as shown.

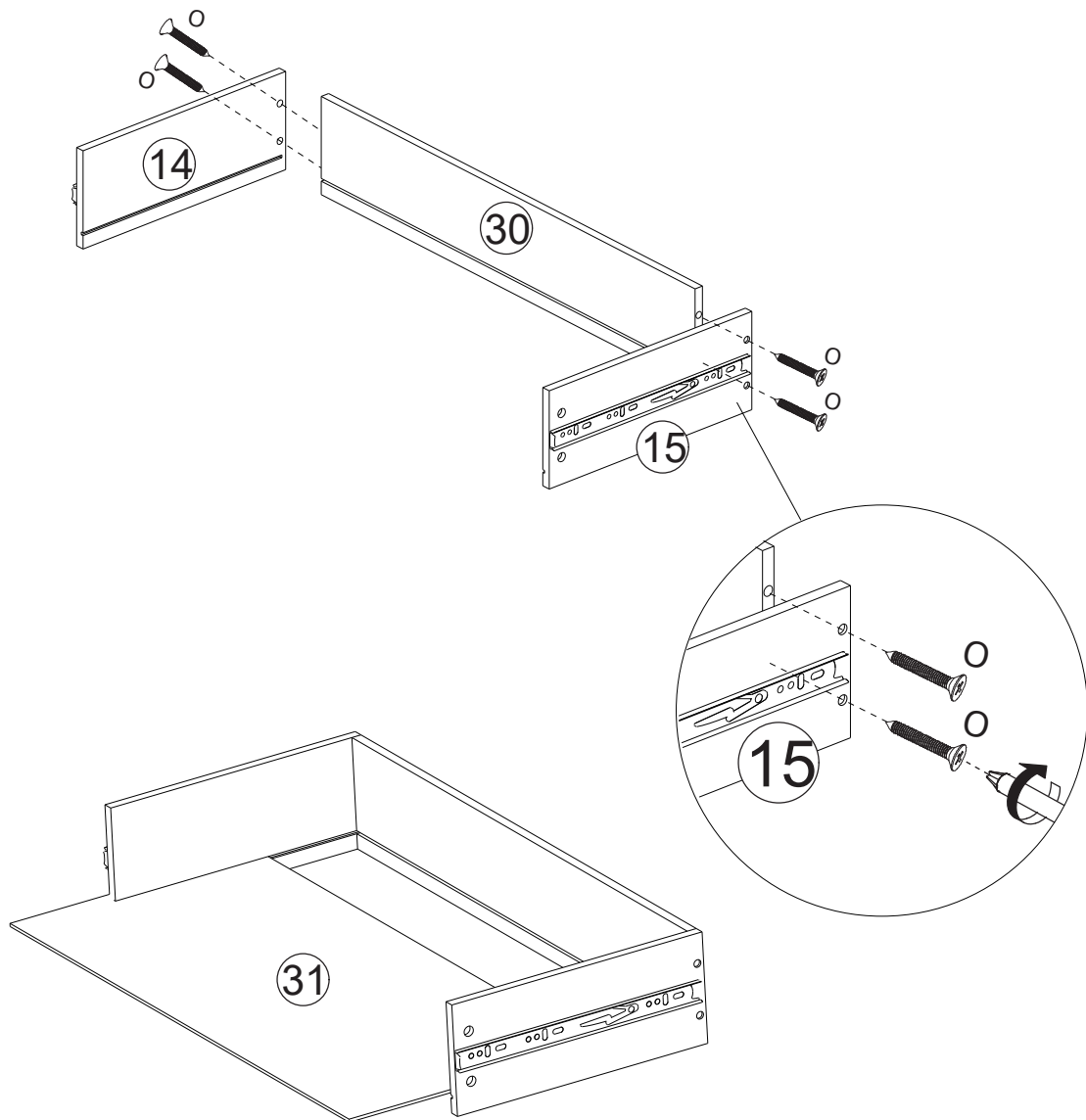

35

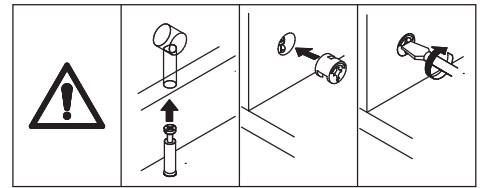
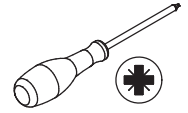
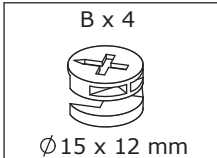

Attach plate 29 to plate 14 and 15, insert cam lock (B) into holes in plate 14, 15 and turn clockwise to tighten as shown.

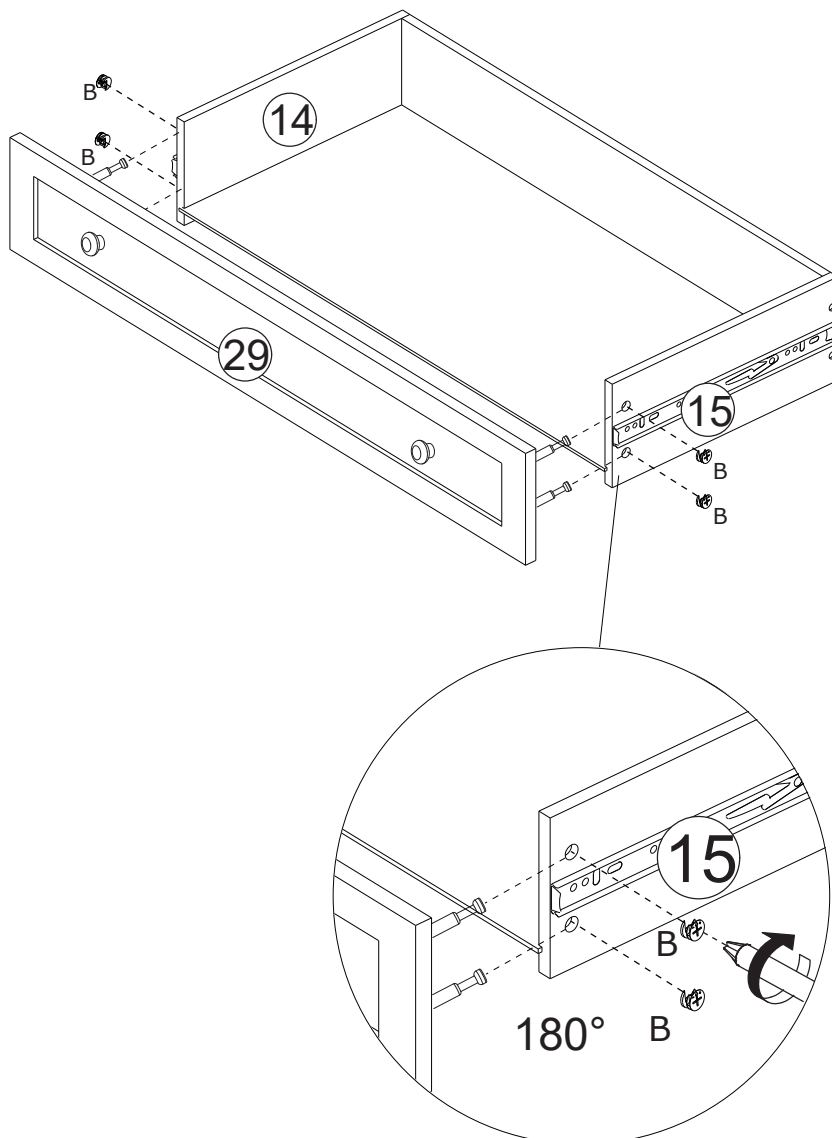

36

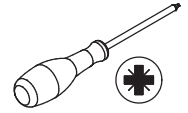

Connect plate 14 and 15 with plate 16 using screw(O) as shown.
Slide plate 17 into available slots as shown.

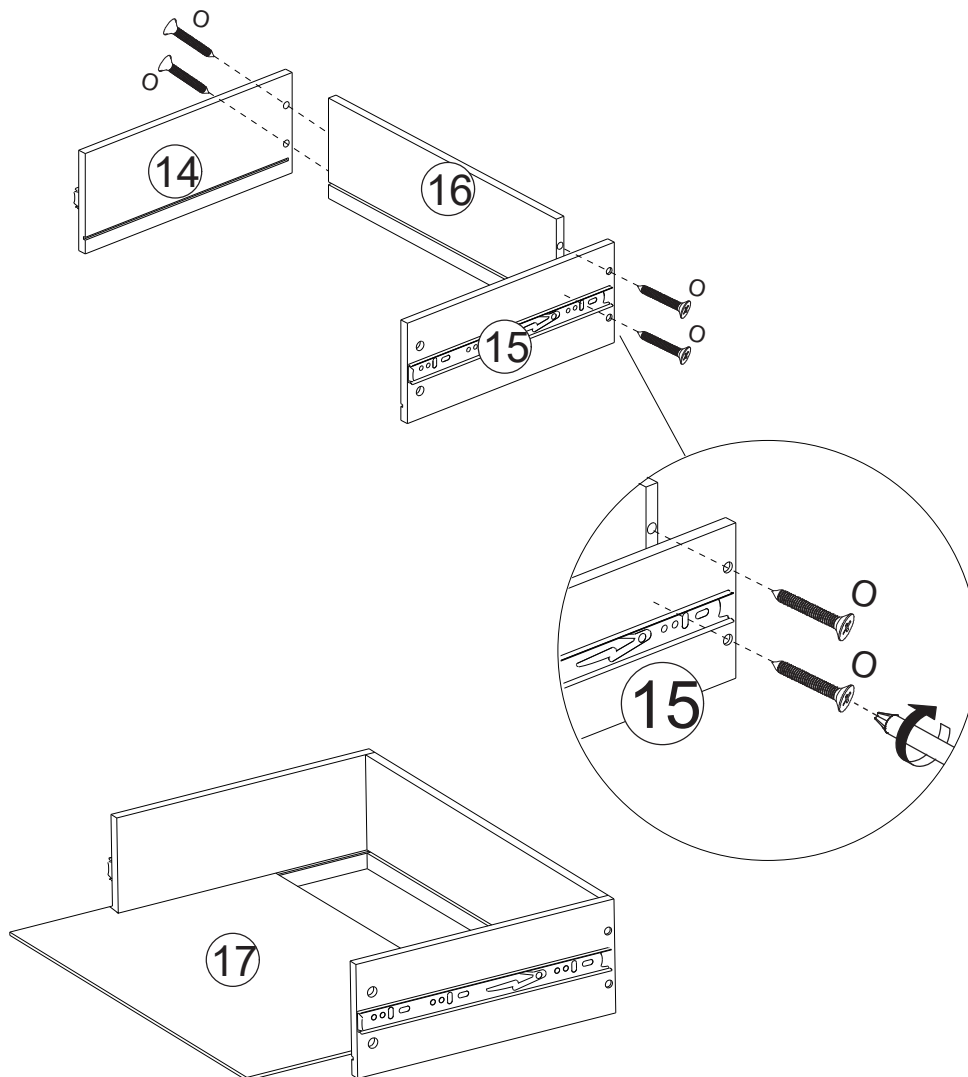

x2

37

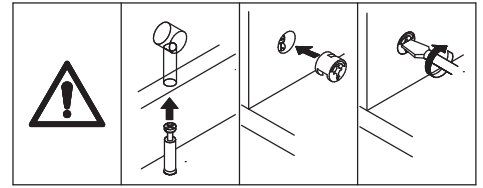
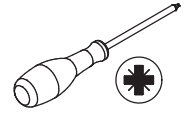
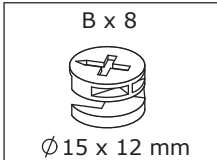

Attach plate 13 to plate 14 and 15, insert cam lock(B) into holes in plate 14,15 and turn clockwise to tighten as shown.

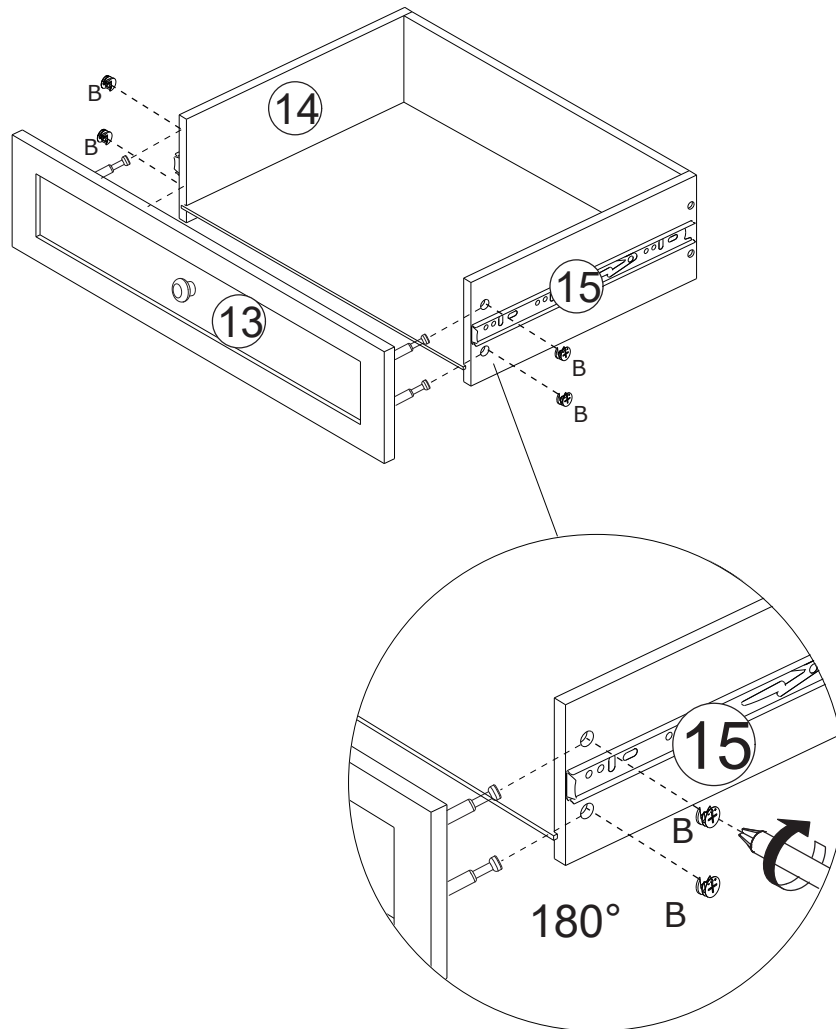

x2

38

Align rails. slide all drawers.

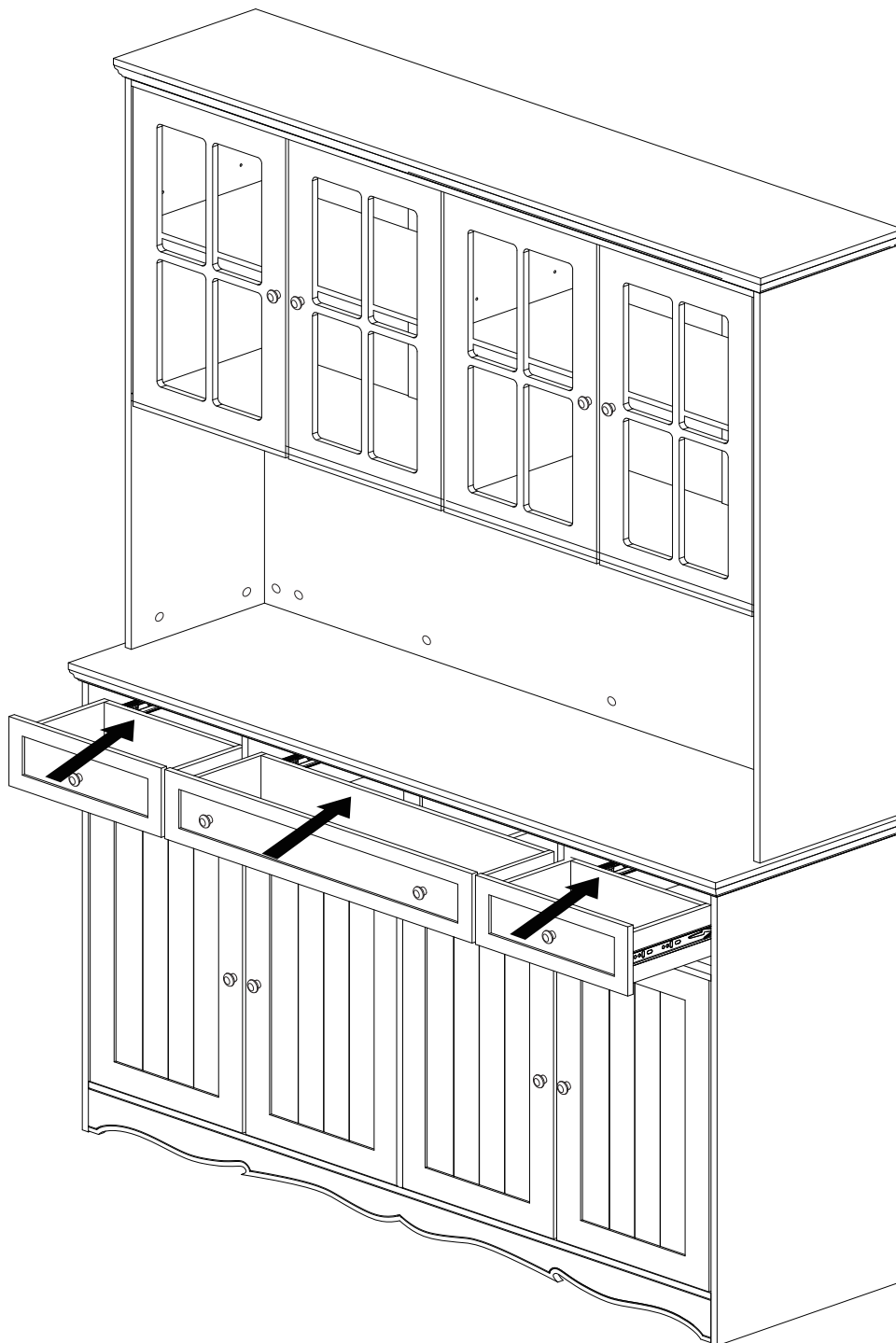

39

S x 16

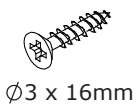

R x 16

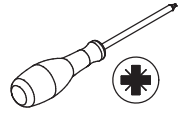

Reinforce back plate using part(R)
with screw(S) as shown.

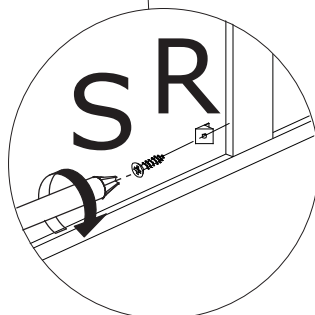
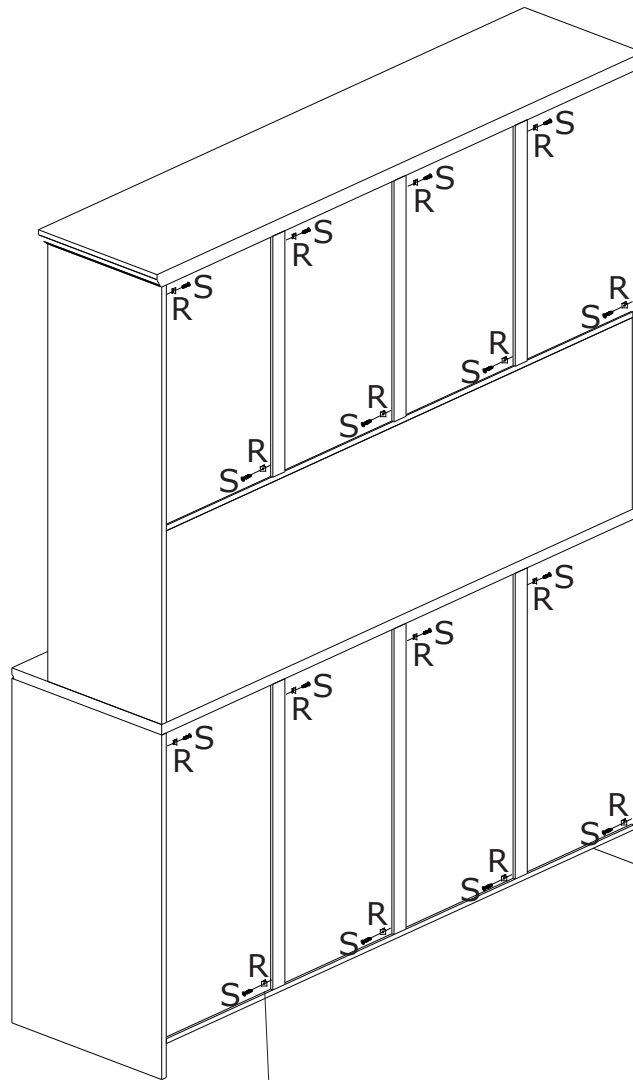

40

O x 4

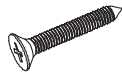

Ø4 x 30 mm

C x 4



Ø3 x 12 mm

J x 2



K x 4

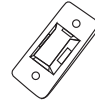

L x 2

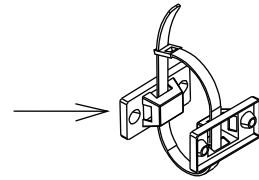
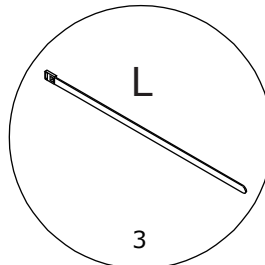
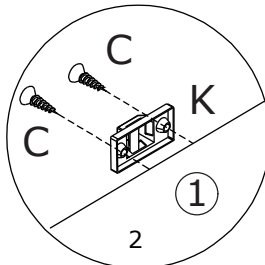
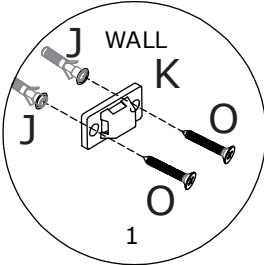
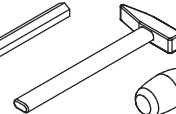
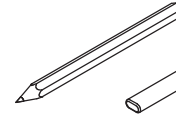

Install anti-tipping device as shown.

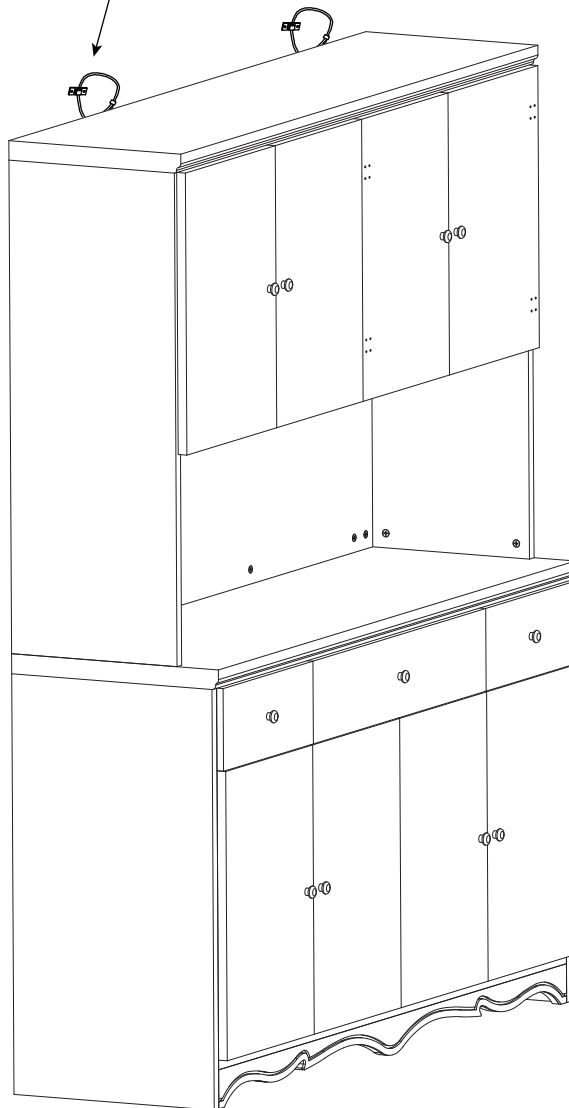

44/44

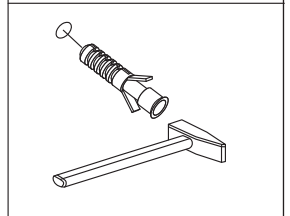
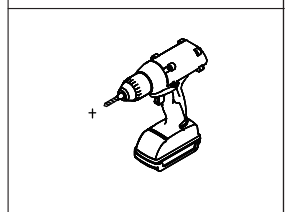
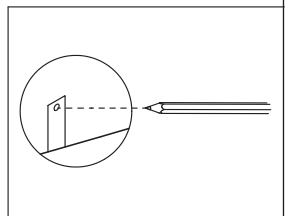

WARRANTY

WARRANTY CLAIMS

- There is a 30-day warranty for broken furniture or any other problems that do not work properly. The warranty will start from the date of purchase which must be verified by proof of purchase.
- Before making a claim, we may be able to answer your query, simply call us. Please leave your purchase order number, along with some details of the problem, if you want a replacement part. We will arrange within 48 hours. If there is out of stock, we will reply with a shipping date.
- The product must be used in accordance with the instructions provided. For health reasons.
- For other reasons, if the furniture needs to be returned, it must be cleaned and dried and operated within 30 days of receipt.

Type of Warranty Claim

- Failure to follow the furniture instructions will invalidate the warranty. Attention please.
- Does not include damage during installation, but includes damage during transportation.

Scope of responsibility

- Shall not bear any responsibility for misuse or user damage and / or loss of parts during the installation of furniture.
- After using, the damage and scratches of the furniture are not covered by the warranty.

The Warranty Relates to All Bought in The Us and Covers The Following Areas

- Sheet parts: 1 month from the date of purchase.
- Electrical parts: 1 month from the date of purchase.

RETURNS

CHANGED YOUR MIND AND NEED TO RETURN YOU ITEM?

PLEASE FOLLOW THE BELOW INSTRUCTIONS:

- If you have purchased and have simply changed your mind, follow the retailer's instructions for returns.

DEFECTIVE ITEMS

- If your item is defective in any way, i.e. it doesn't work but you can't identify why, in the first instance, please call us.

DAMAGED ITEMS

- If you receive an order with obvious shipping damage from the retailer, then we suggest the delivery is refused. If the delivery has been accepted and then shipping damage is found, please follow the specific instructions advised by the retailer.
In all circumstances please save all packaging material and paperwork for the order. Please be aware that if you dispose of packaging material or attempt to return the merchandise without contacting the fulfiller, you jeopardise your chances of making a claim, and you may not receive a credit for the return.