

Kitchen Island

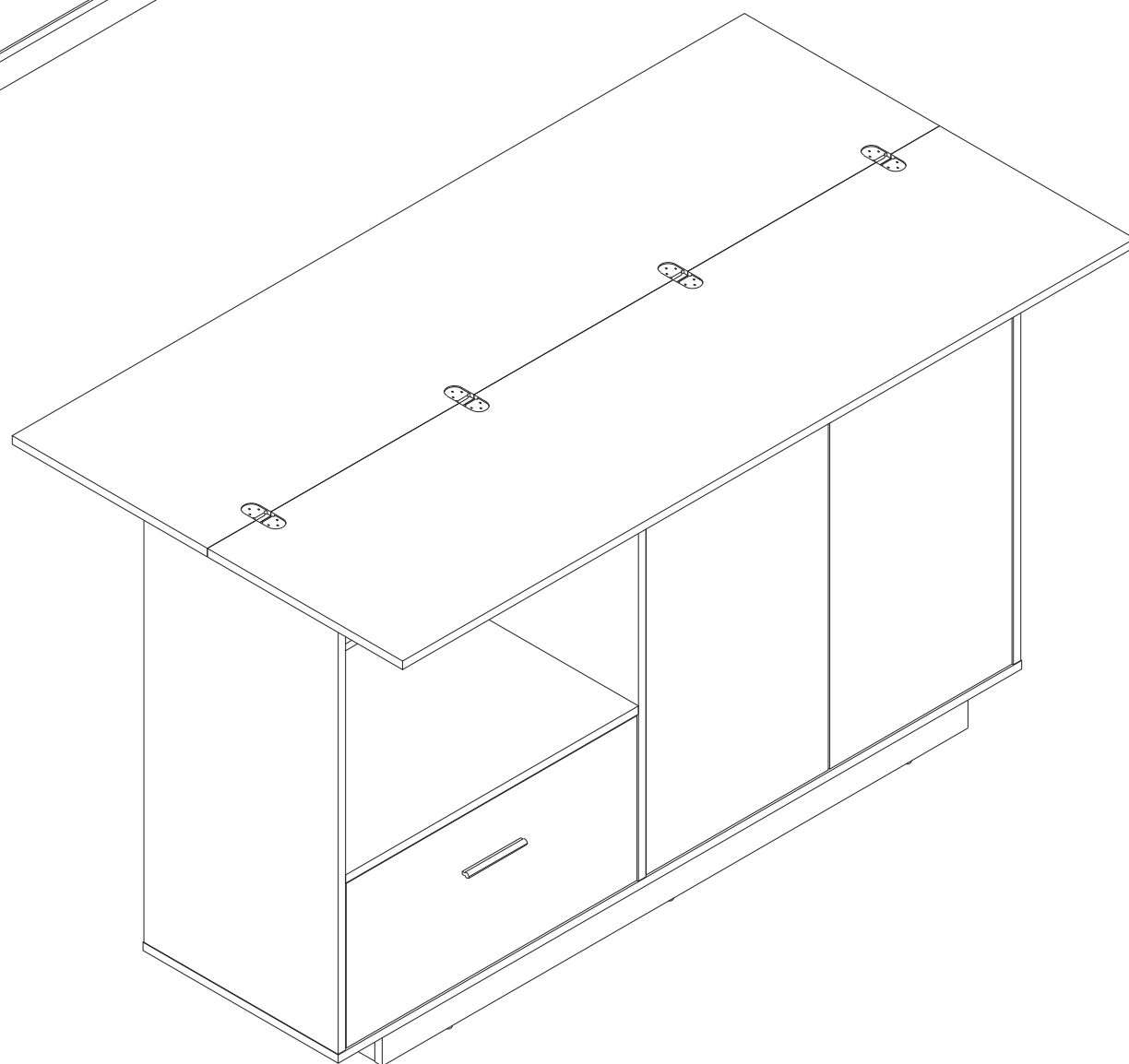

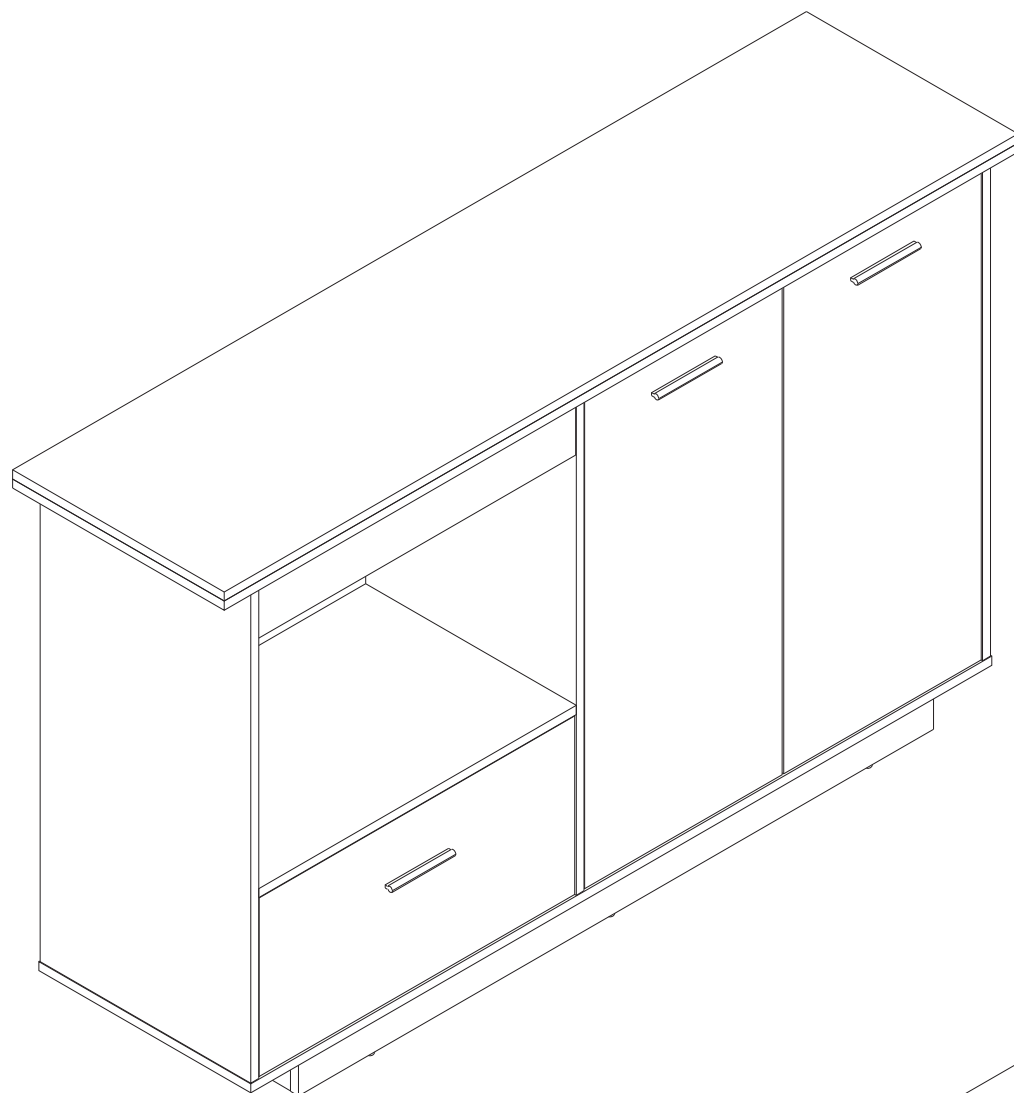
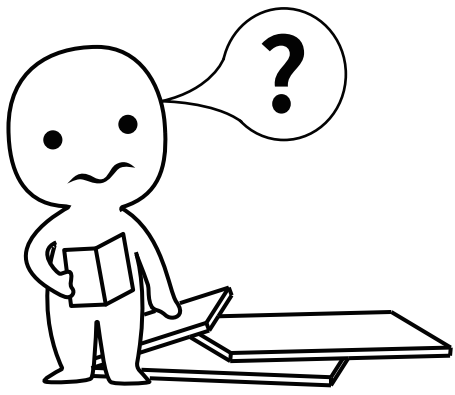

IMPORTANT INFORMATION!

please read the entire manual before starting to assemble and/or using this product. follow the manual thoroughly and keep it for further reference.

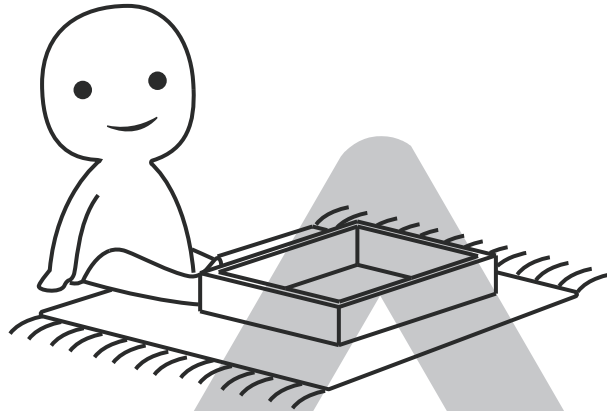
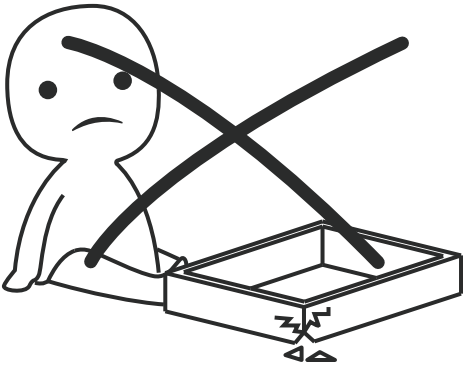

AVOID SCRATCHES!

In order to avoid scratching this furniture should be assembled on a soft layer - could be a rug.

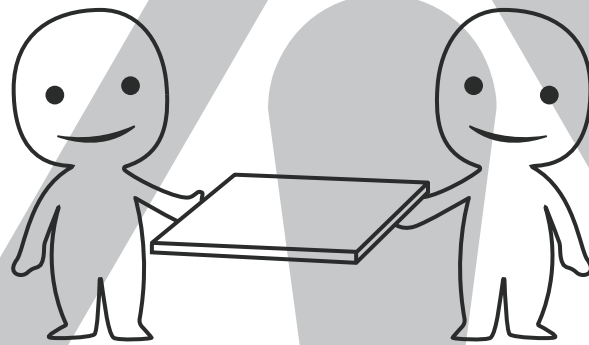

IMPROVE EFFICIENCY !

Try to find a partner to install with you, which can speed up the installation efficiency and shorten the time.

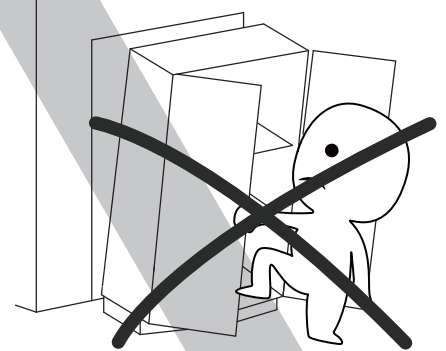
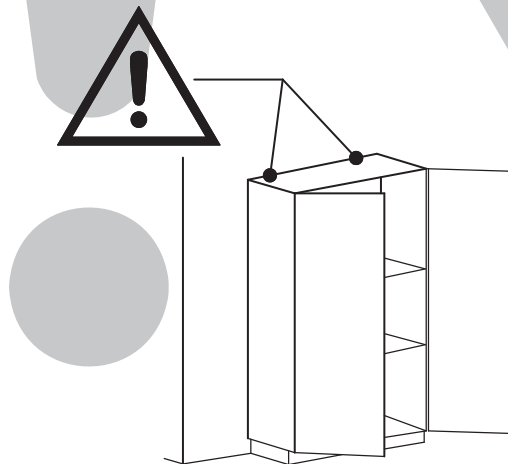
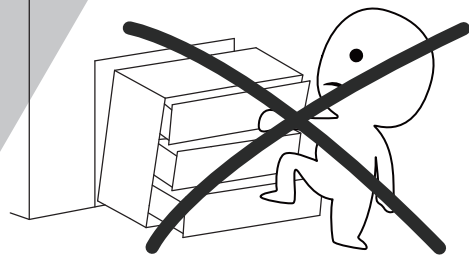
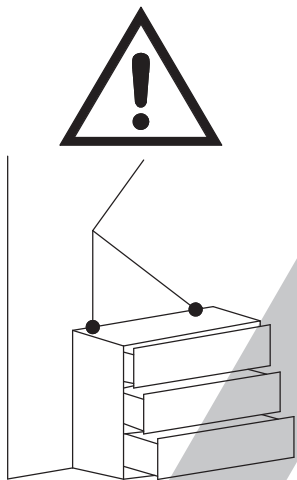

ANTI-TOPPLE WARNING !

Overtipped furniture can cause serious or fatal crush injuries. To prevent tipping over, be sure to use the wall attachment, if not included with this product. Please purchase the wall attachment that fit your wall. If unsure, seek professional advice. Please read and follow each step of the instructions carefully.

IMPORTANT !

It is important that any product which is assembled using any kind of screw is re-tightened 2 weeks after assembly, and once every 3 months - in order to assure stability through-out the lifespan of the product.

For regular maintenance and cleaning of the product, for the frame, please use a rag dipped in neutral detergent to fully wipe it, and then dry it with a clean rag. For glass materials, wipe with a rag dampened with water glass cleaner, and then dry with a dry rag.

Do not use an electric screwdriver, and do not use too much force when installing, because the board is easy to break.

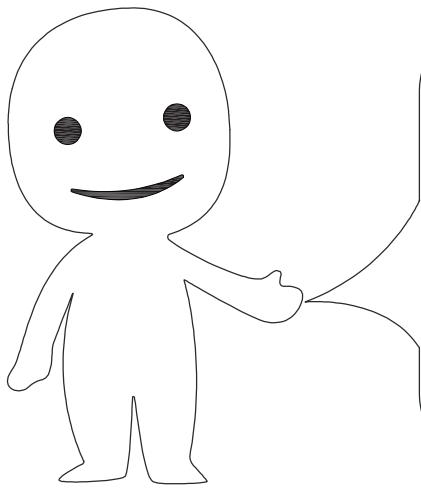

Please prepare the following tools

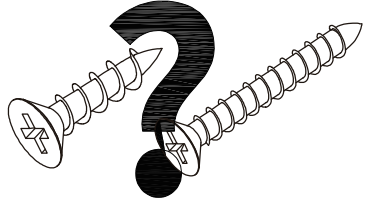
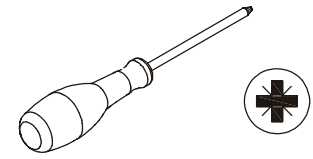
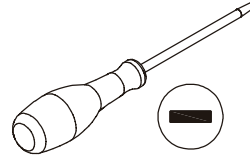
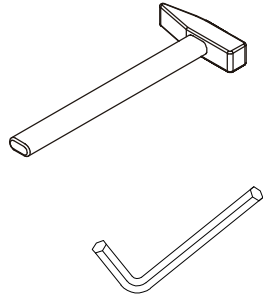

When installing, please carefully confirm whether each screw corresponds to the manual, accessories with similar shapes can be distinguished by size

A x 54

M5 x 42 mm

B x 54

∅ 15 x 10 mm

C x 44

M3.5 x 14 mm

D x 6

∅ 8 x 40 mm

E x 8

M7 x 50 mm

F x 8

∅ 5 mm

G x 4

DW

H x 4

M5 x 40 mm

I x 3

M4*16

220-96

J x 1

36 x 21 mm

K x 4

M3.5 x 12 mm

x 1

#4

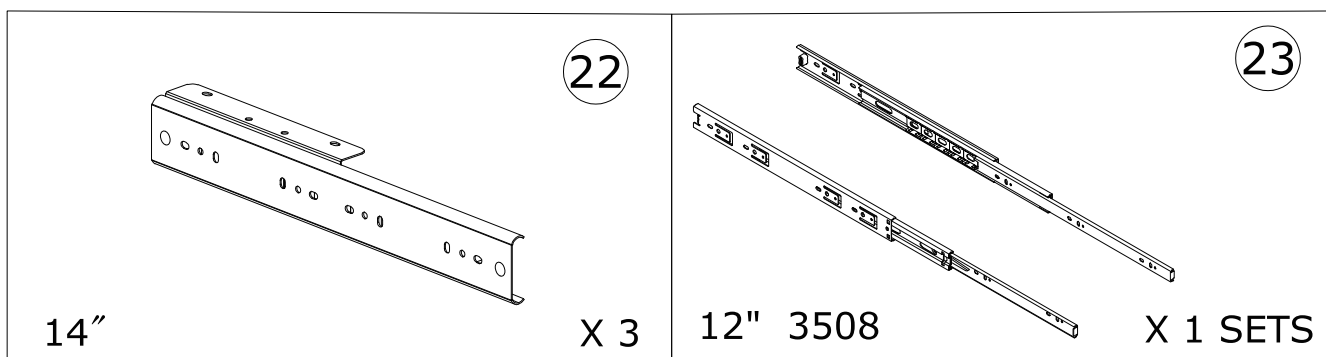
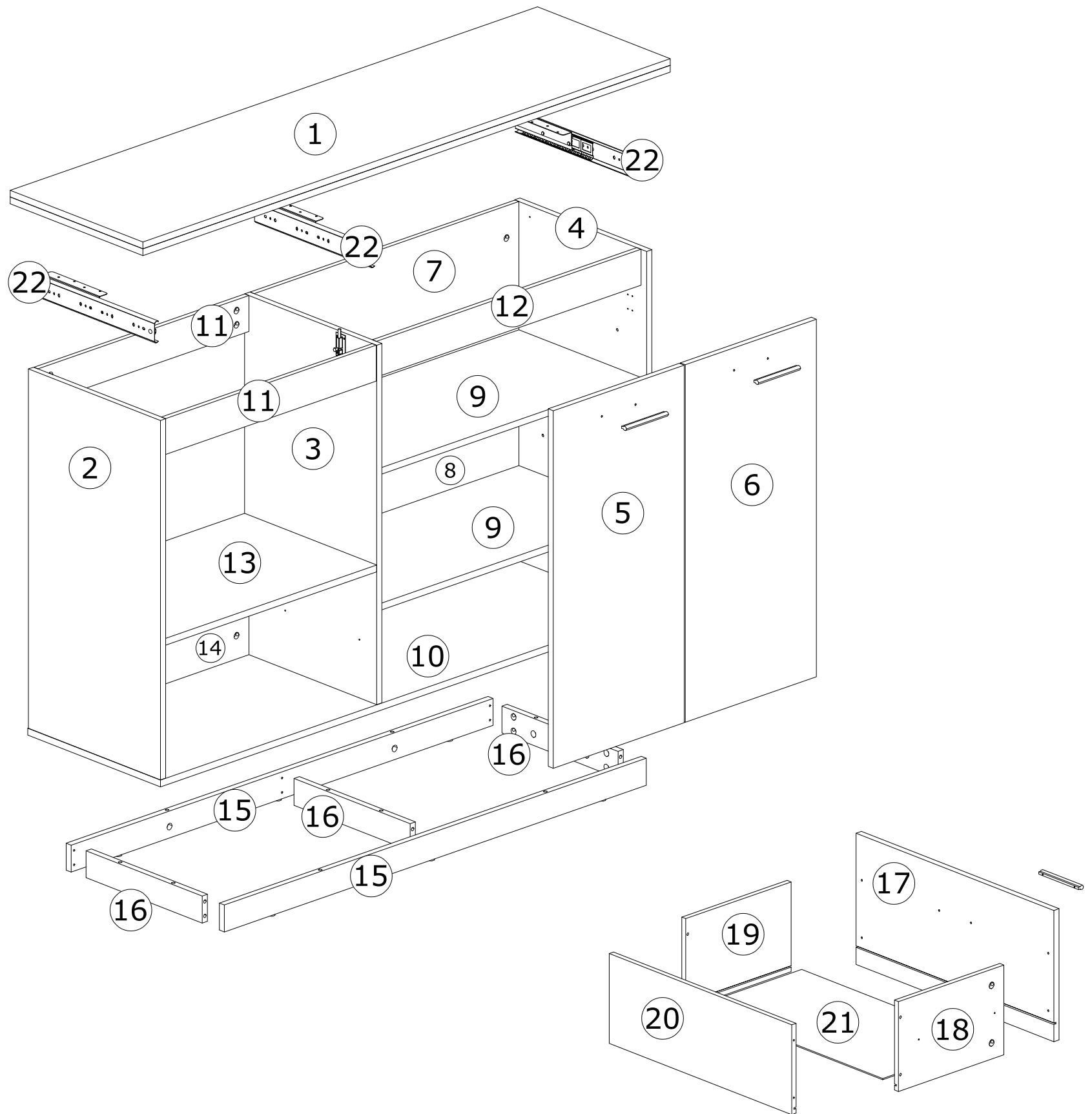

**Slides Must Be Separated Before Assembly.
After Separated, Set Aside Until Needed for Assembly.**

Las diapositivas deben separarse antes del montaje.
Después de la separación, déjelo a un lado hasta que sea necesario.

Les glissières doivent être séparées avant l'assemblage.
Après la séparation, mettez de côté jusqu'au moment de l'assemblage.

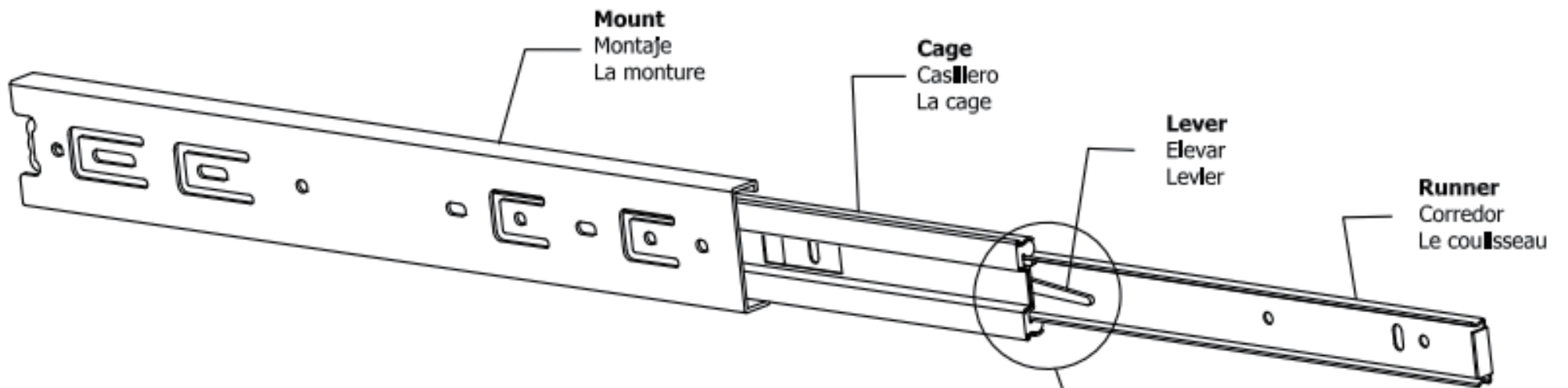

STEP 1: Extend Slide
Extender la diapositiva
Extendre la diapositive

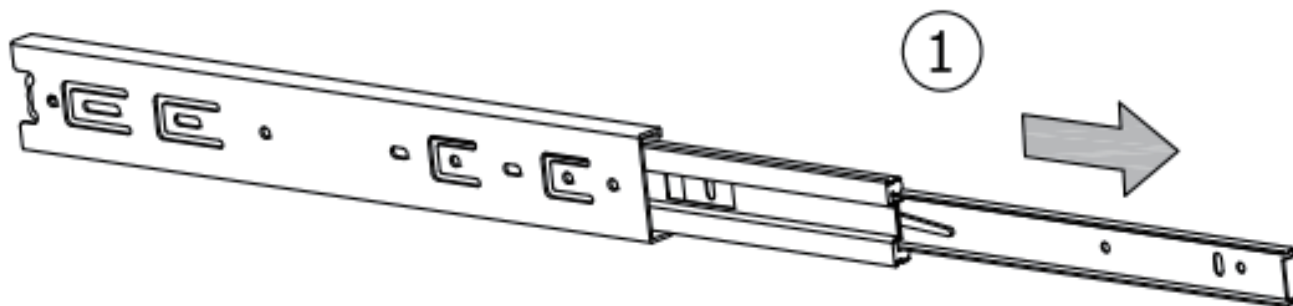

STEP 2: Push Lever UP
Empujar hacia arriba
Lever le levier

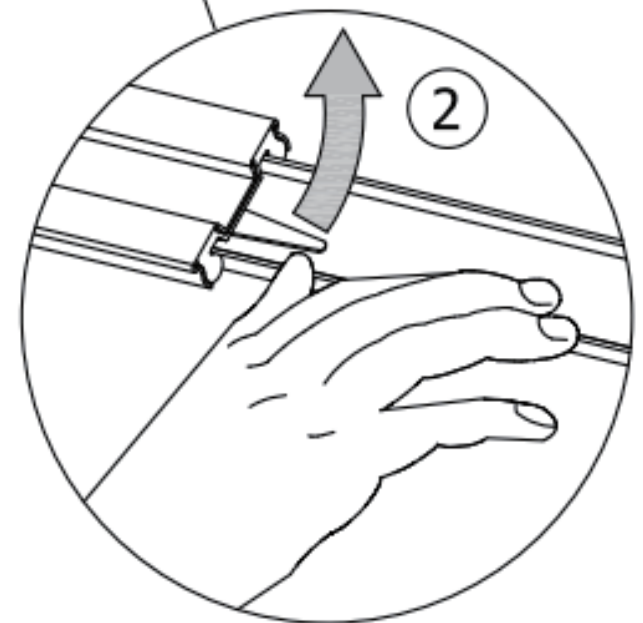

STEP 3: Remove Runner
Quitar el corredor
Enlever le coureur

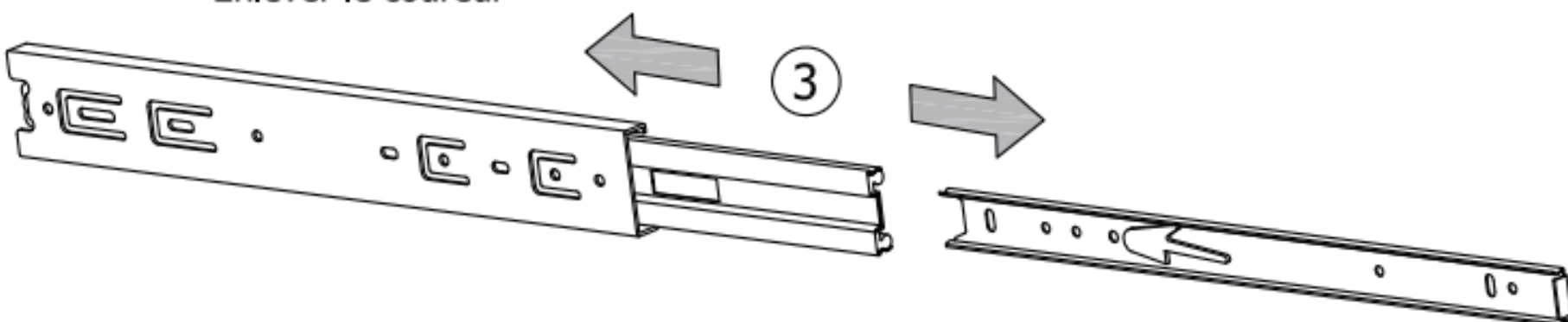

1

C x 4



M3.5x14 mm

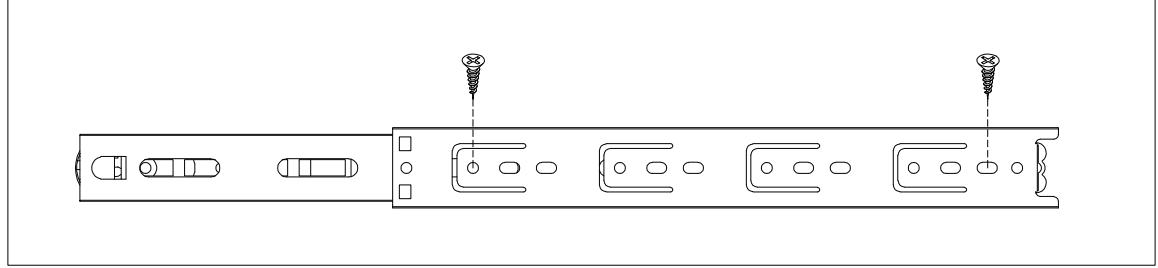
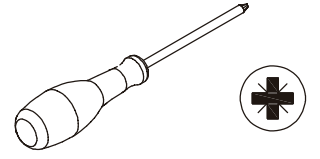

Separate glides into two parts at first.
Fix slide rail 23 to plate 2 and 3 respectively
using screw(C) as shown.

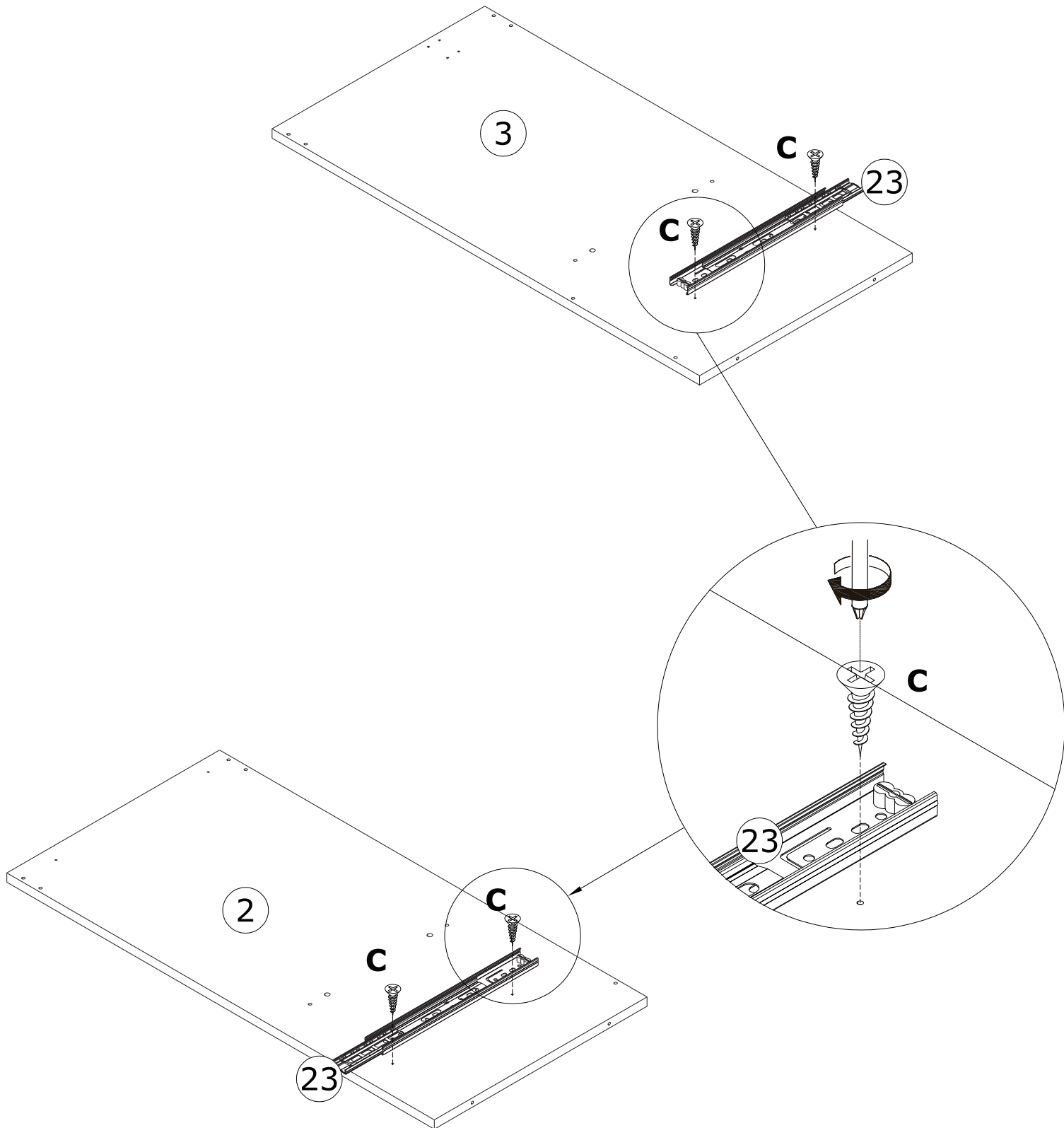



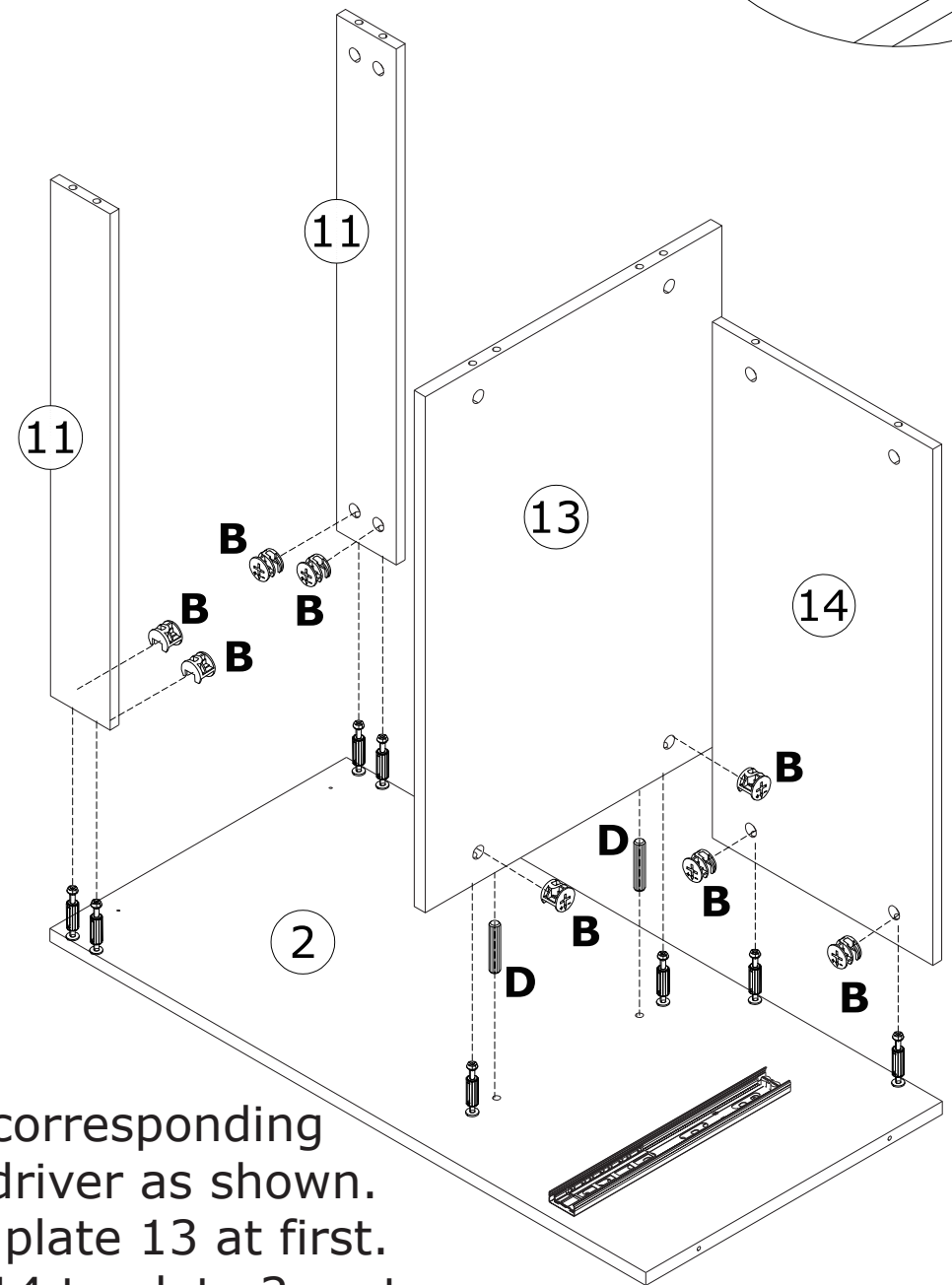
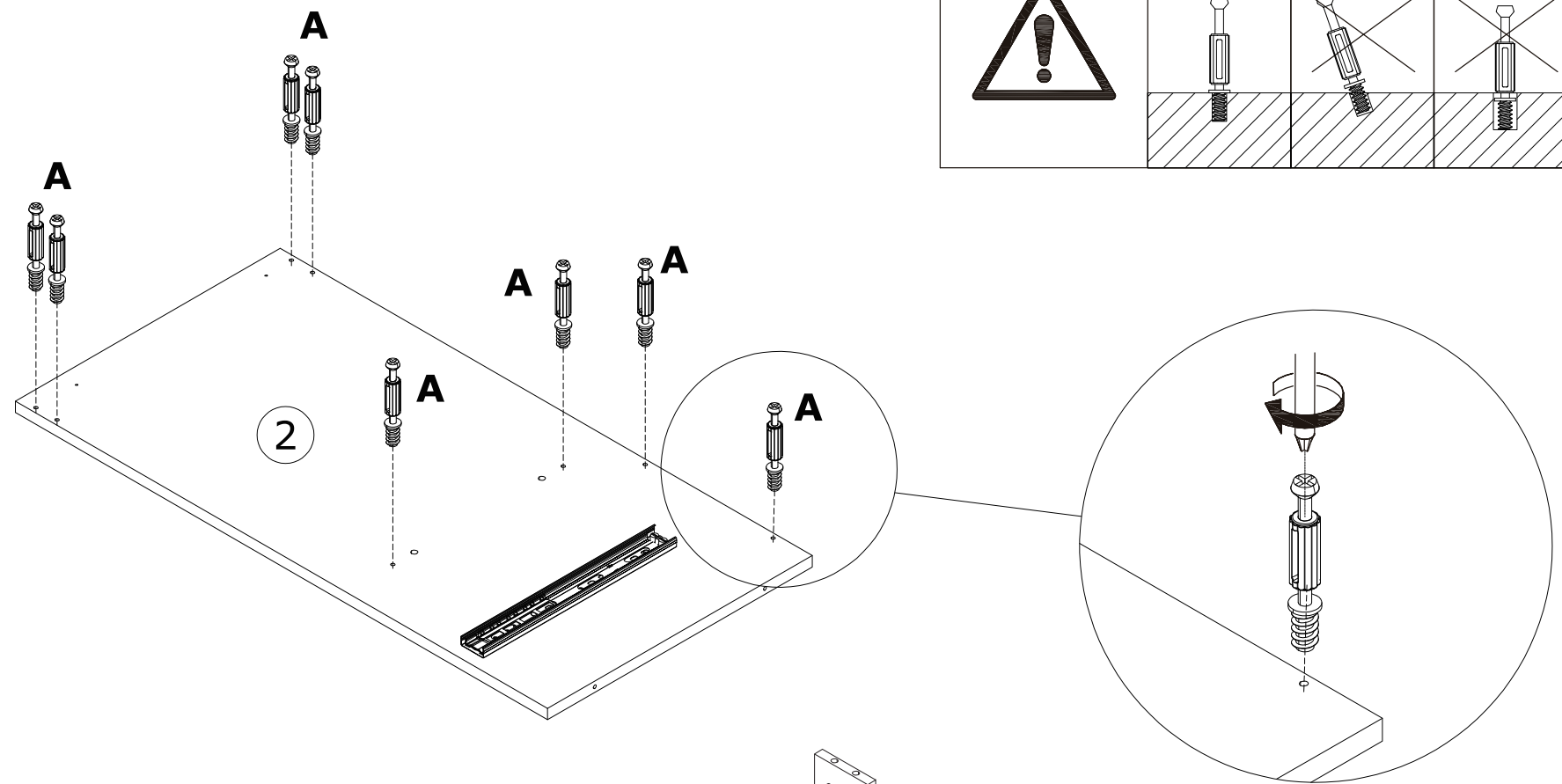
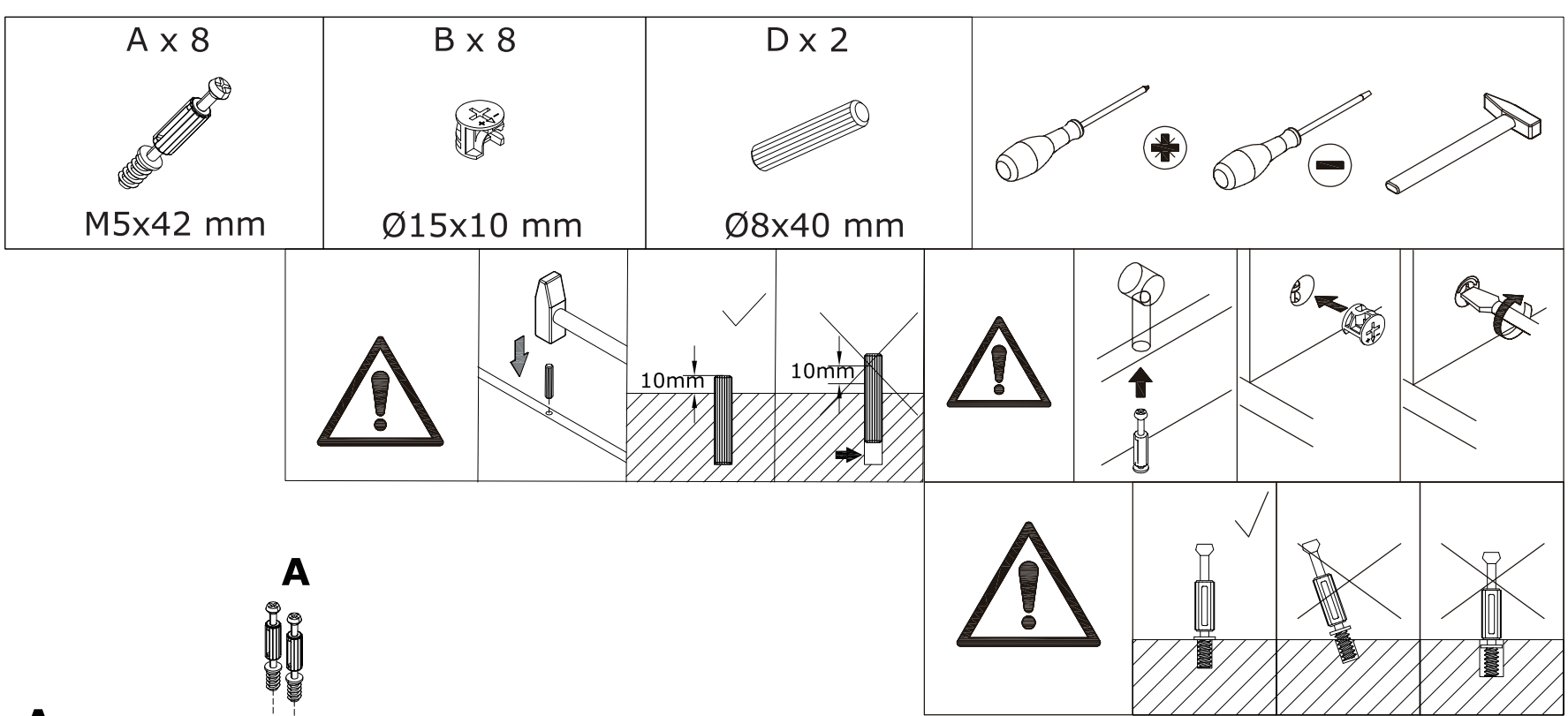



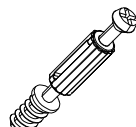

2

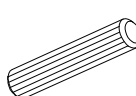
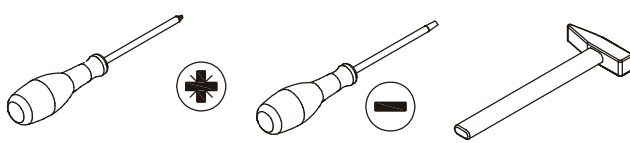

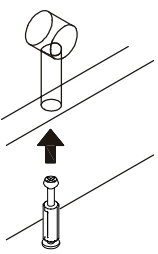
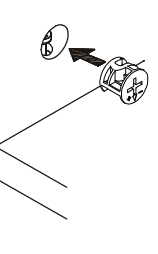
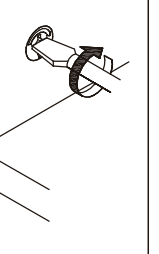
Insert quickfit screw(A) into corresponding holes in plate 2 with a screwdriver as shown. Insert wooden dowel(D) into plate 13 at first. Attach plate 11(x2), 13 and 14 to plate 2, put cam lock(B) into holes in plate 11,13,14 and turn clockwise to tighten as shown.

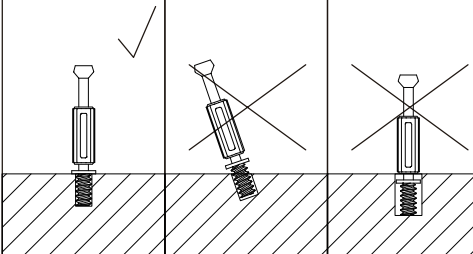
3

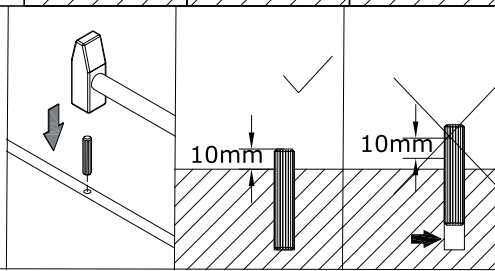
<p>A x 8</p>  <p>M5x42 mm</p>	<p>B x 8</p>  <p>Ø15x10 mm</p>	<p>D x 2</p>  <p>Ø8x40 mm</p>	
 			 
			

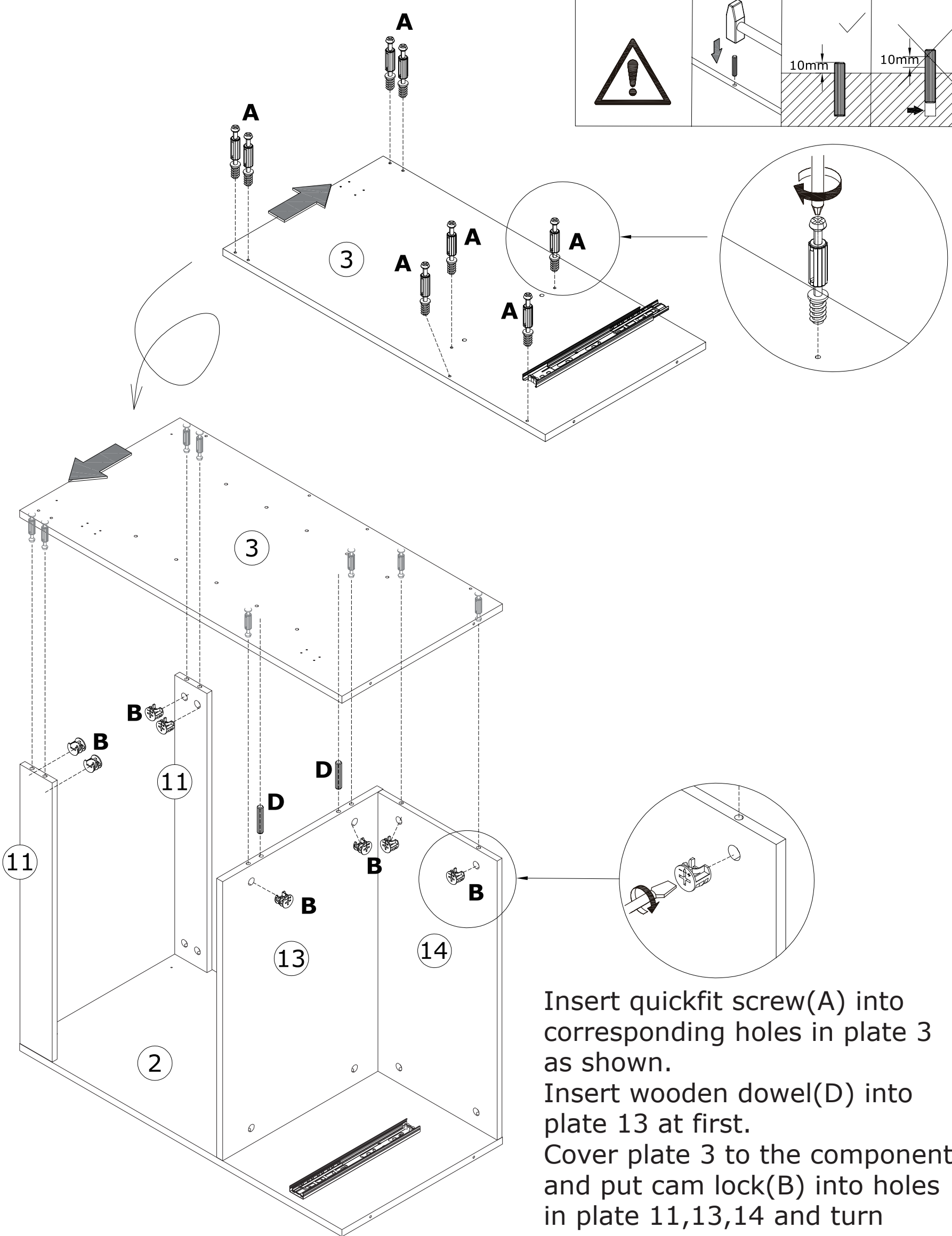

Insert quickfit screw(A) into corresponding holes in plate 3 as shown.
 Insert wooden dowel(D) into plate 13 at first.
 Cover plate 3 to the component and put cam lock(B) into holes in plate 11,13,14 and turn clockwise to tighten as shown.

4

A x 12
M5x42 mm

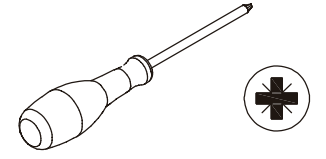

Insert quickfit screw(A) into corresponding holes in plate 3 and 4 as shown.

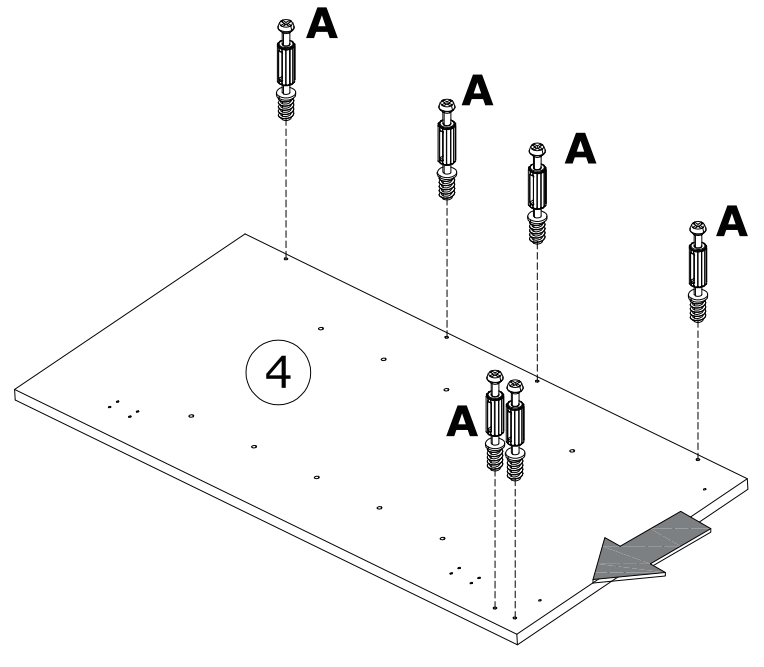
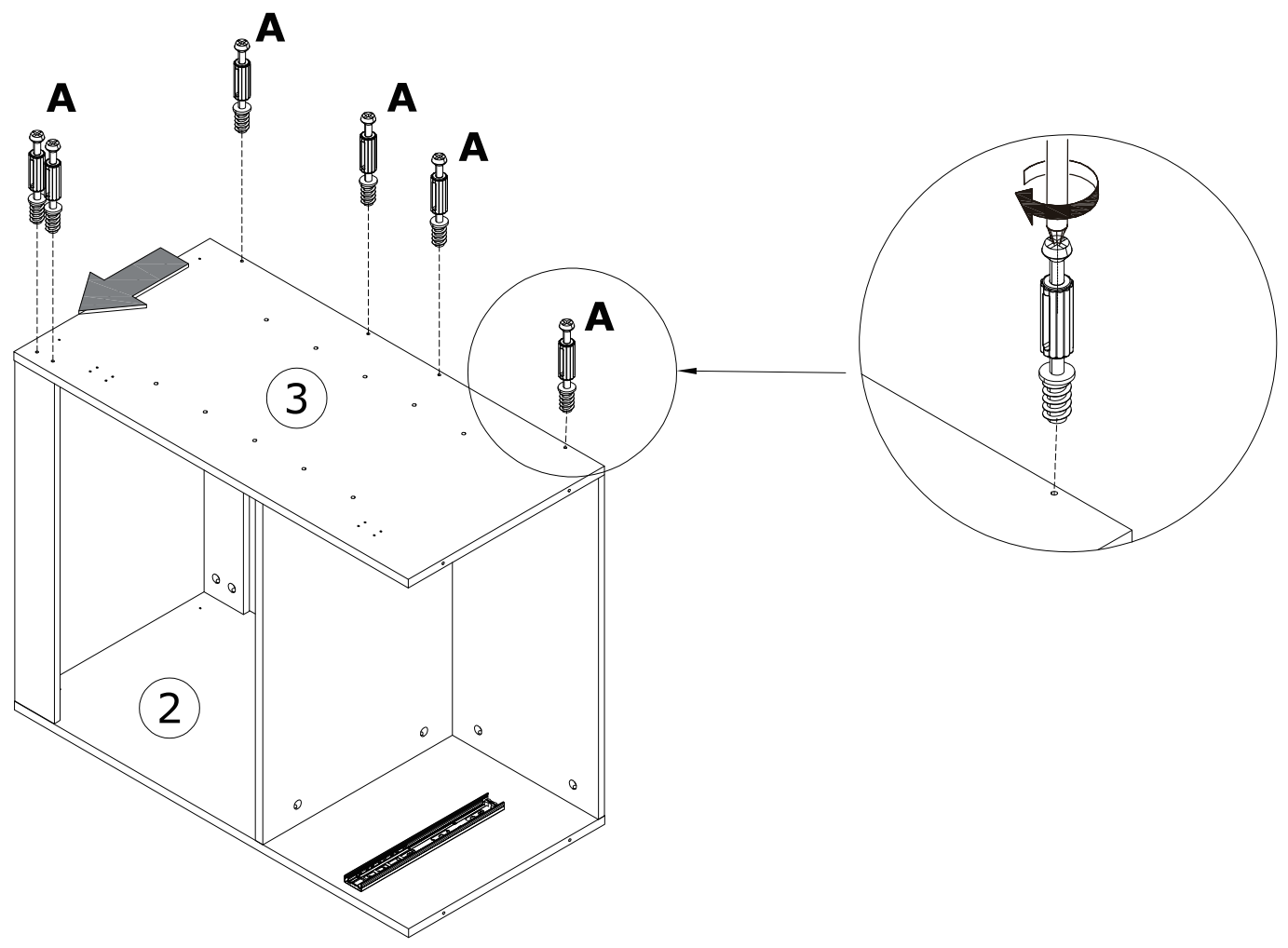

5

D x 2
Ø8x40 mm

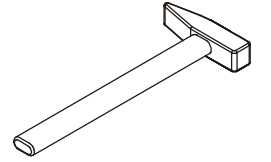

Connect plate 7 with 8 using wooden dowel(D) as shown.

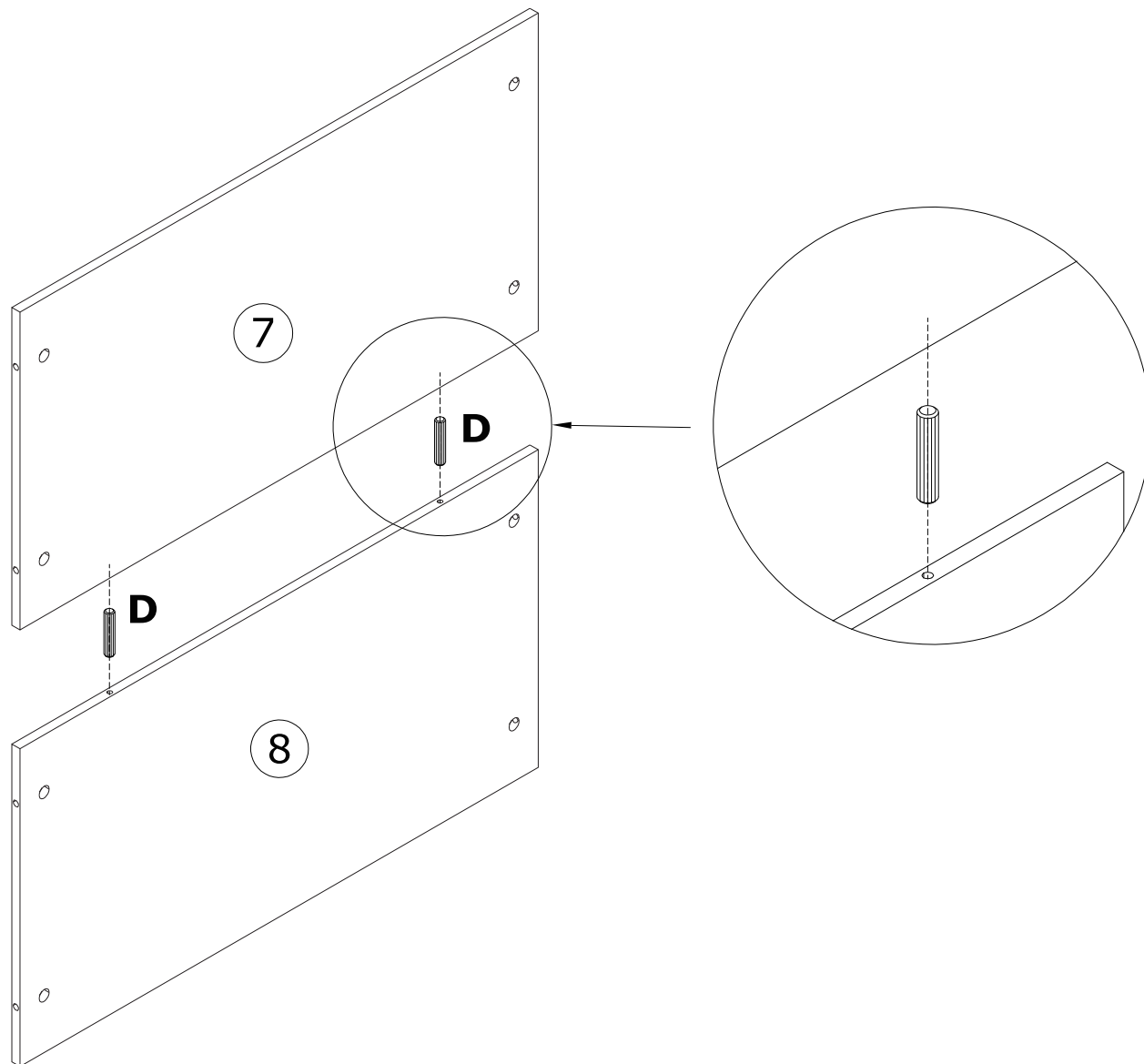

6

B x 12
Ø15x10 mm

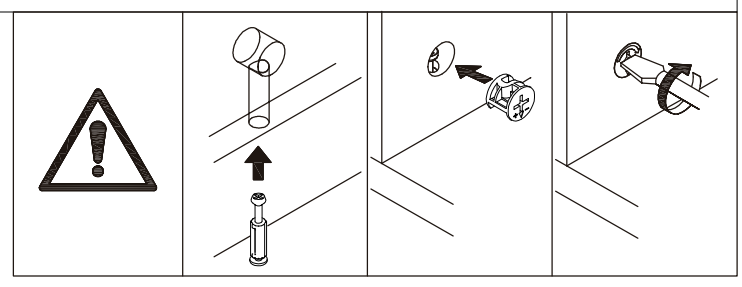
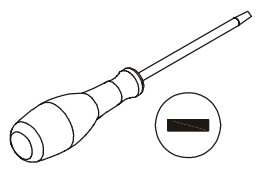

Attach plate 7, 8 and 12 to plate 3 and 4, put cam lock(B) into holes in plate 7,8,12 and turn clockwise to tighten as shown.

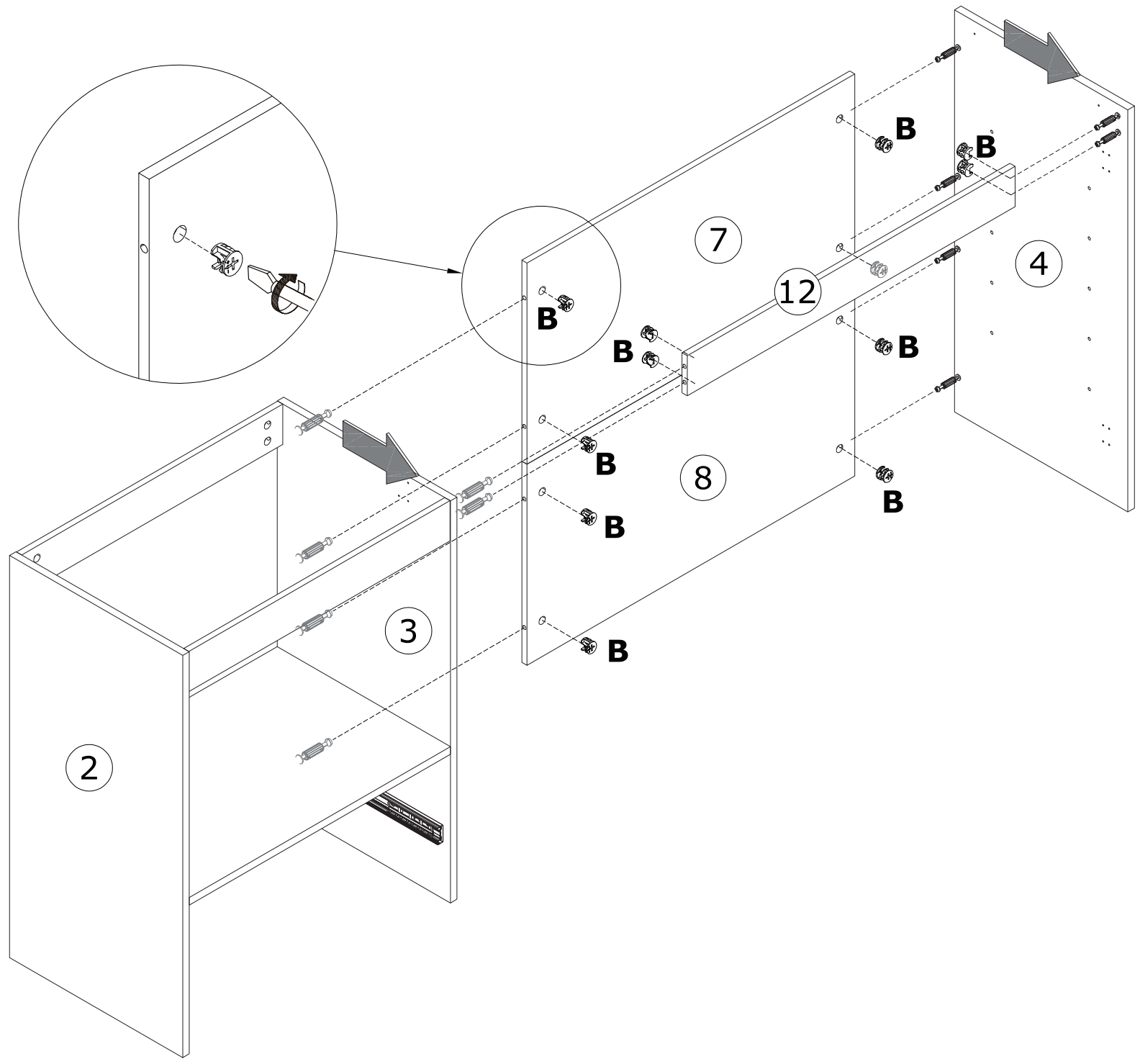

7

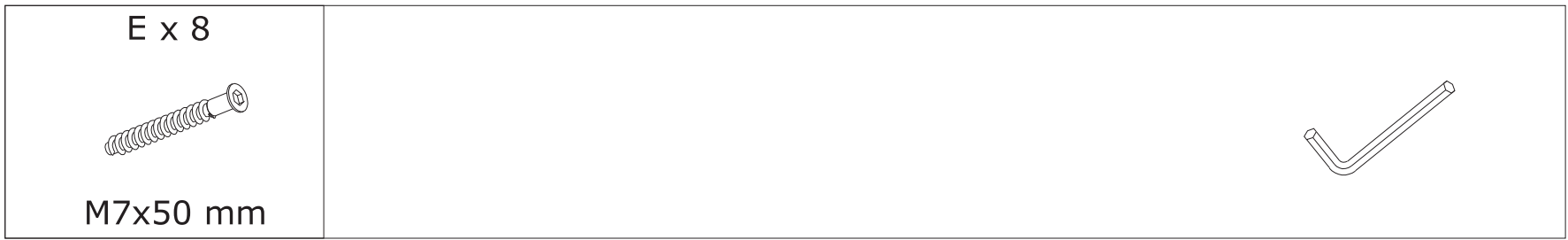

Cover plate 10 to plate 2, 3 and 4 using screw(E) as shown.

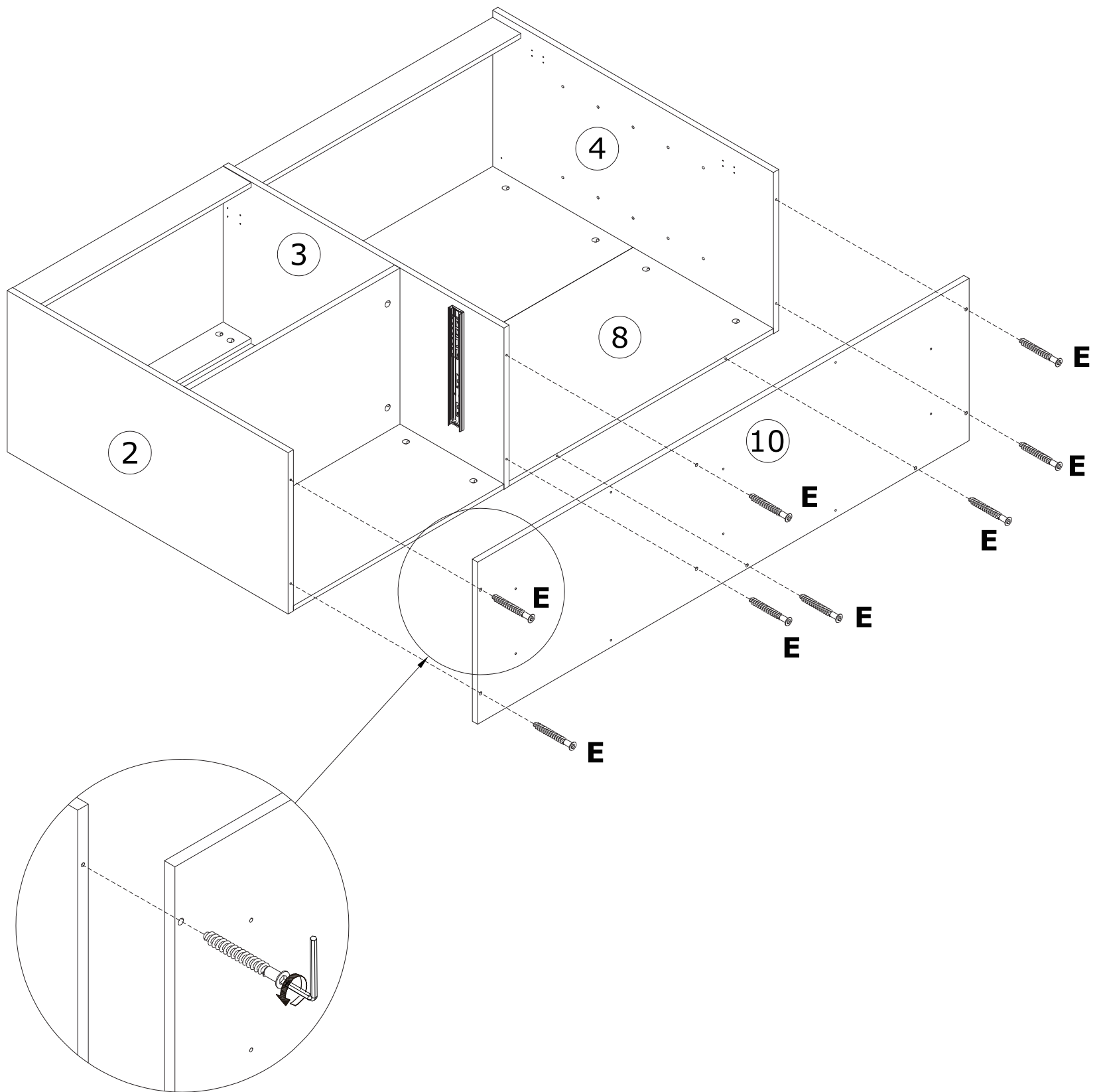

8

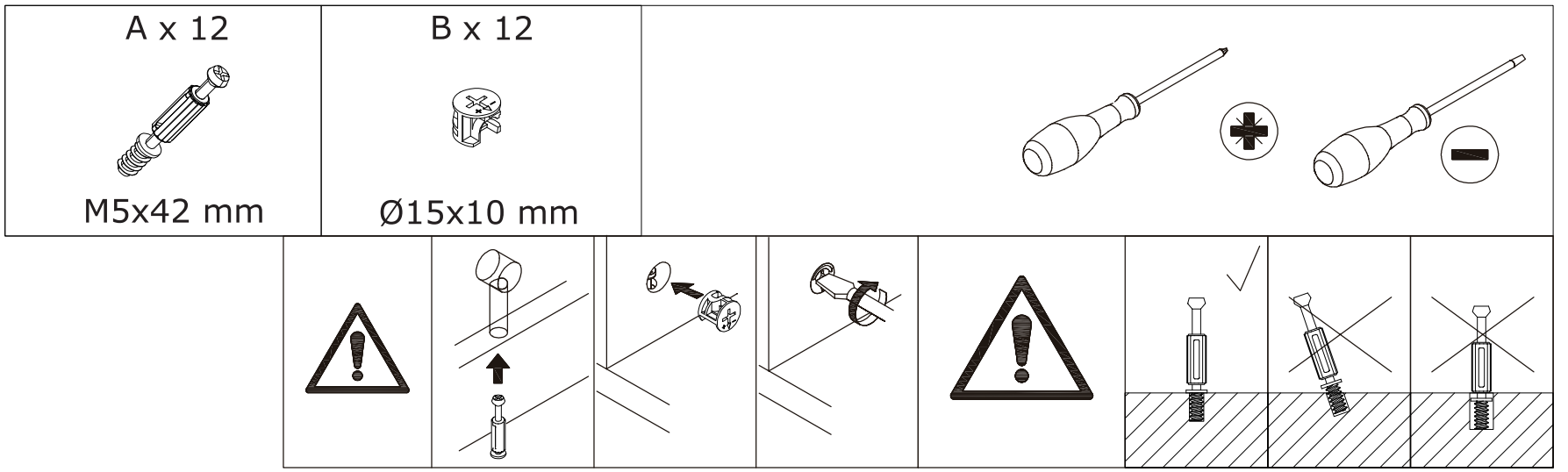

Insert quickfit screw(A) into corresponding holes in plate 15 as shown.
Connect plate 15 with 16, put cam lock(B) into holes in plate 16 and turn clockwise to tighten as shown.

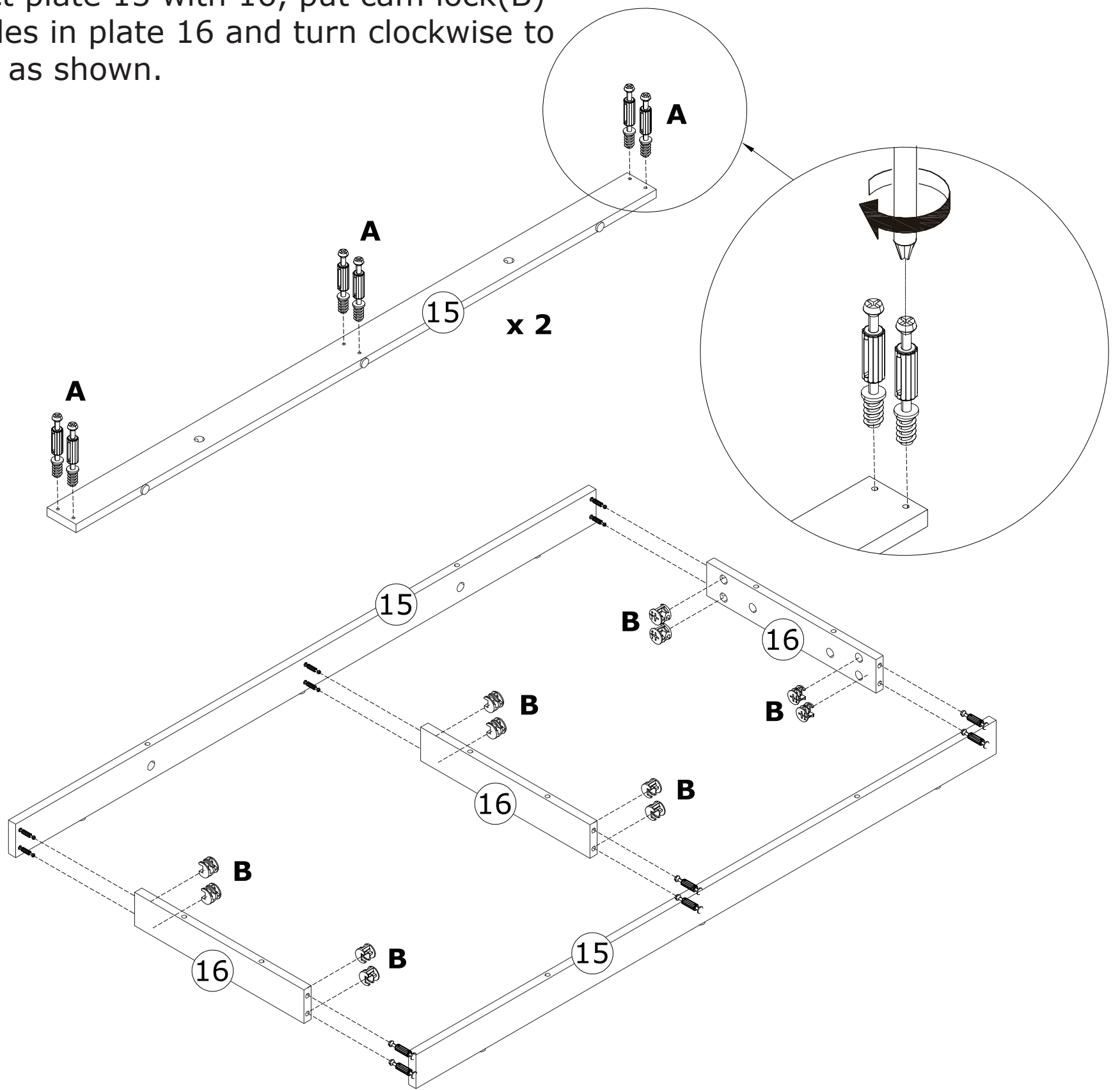

9

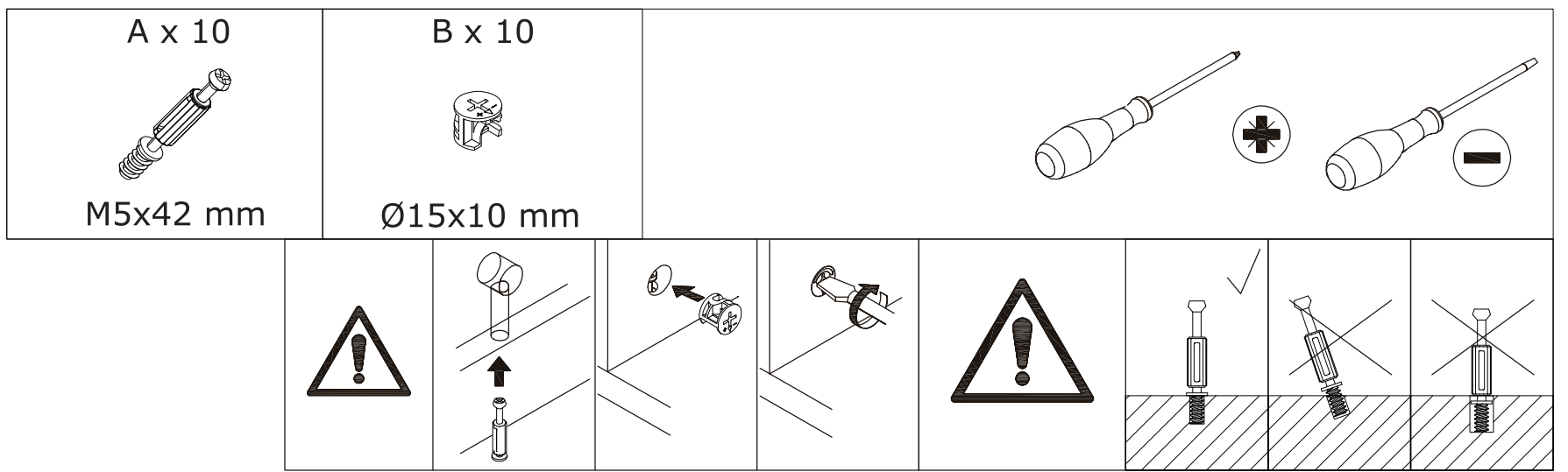

Insert quickfit screw(A) into corresponding holes in plate 10 as shown.
Attach the base component to plate 10, put cam lock(B) into holes in plate 15,16 and turn clockwise to tighten as shown.

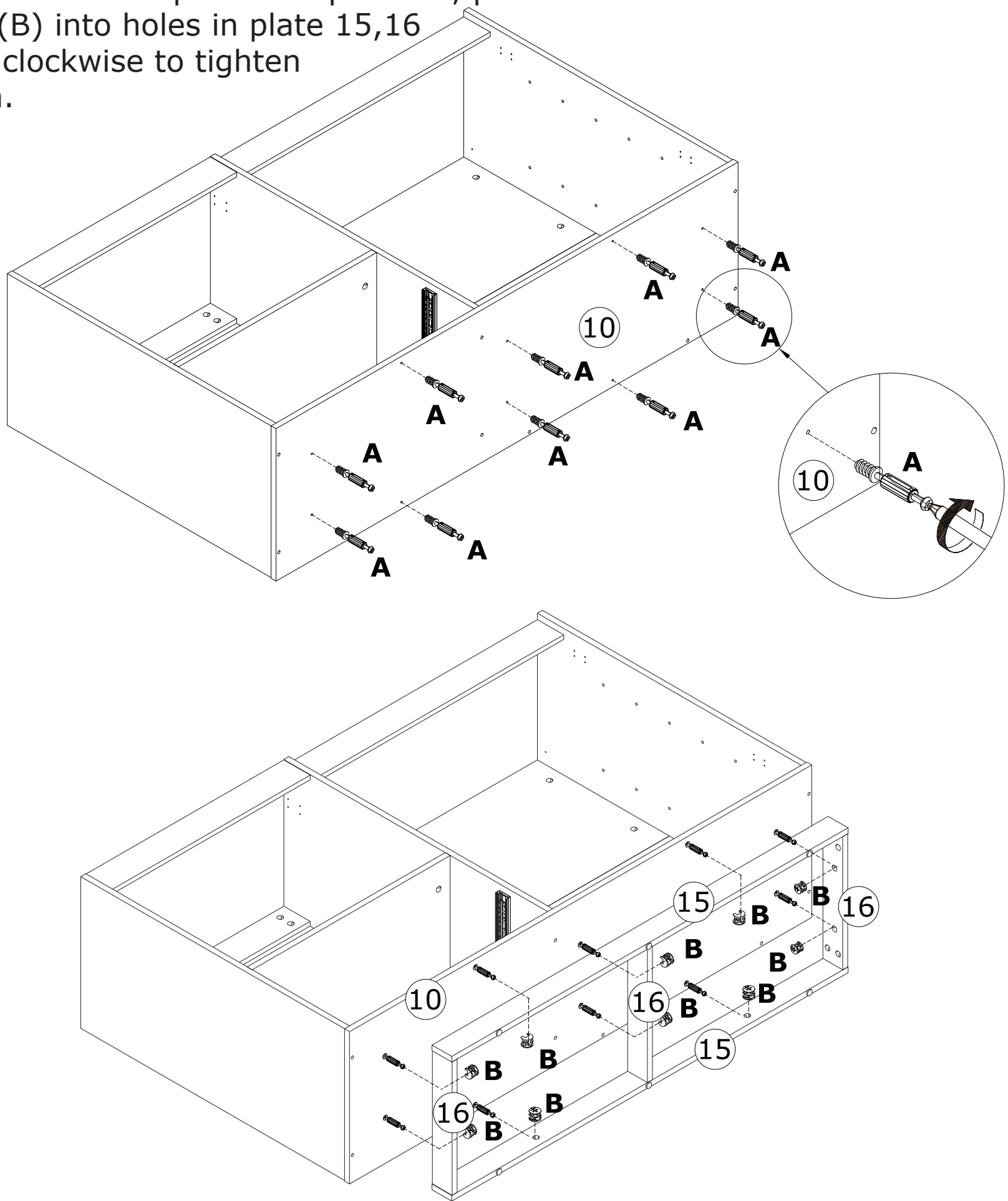

10

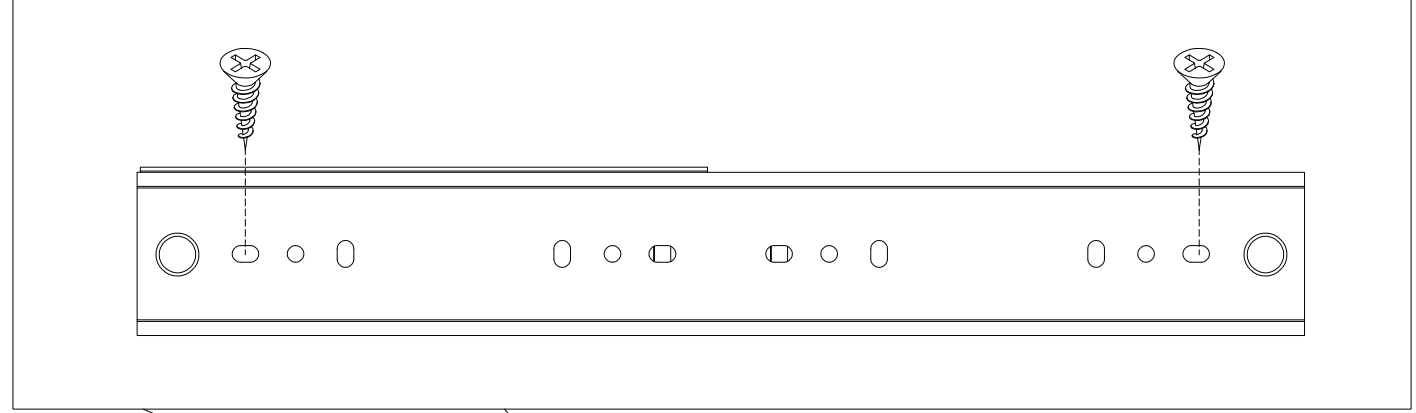
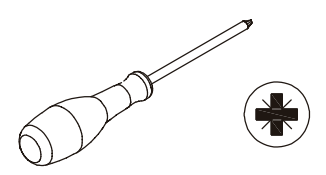

C x 6
M3.5x14 mm

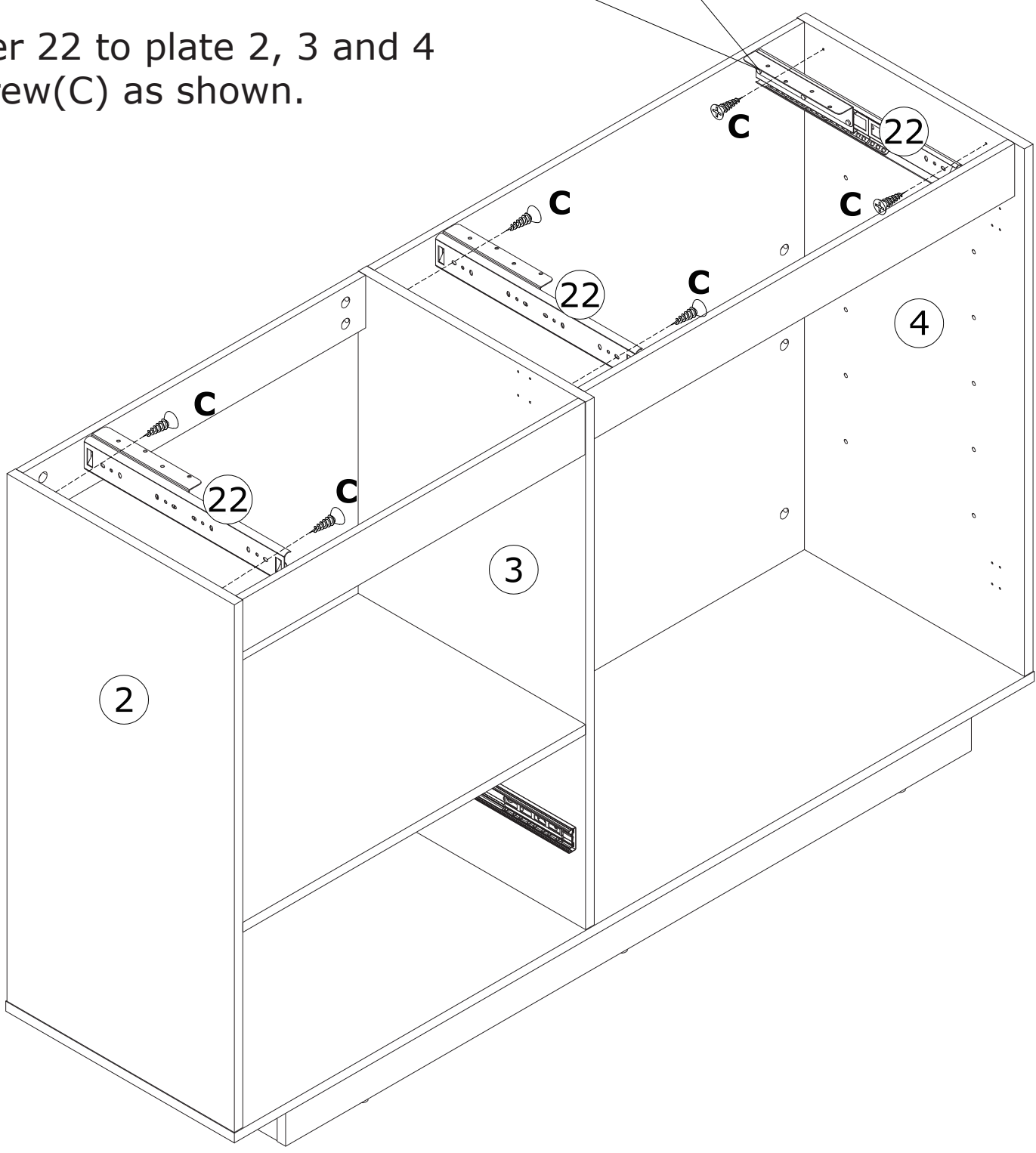

Fix runner 22 to plate 2, 3 and 4 using screw(C) as shown.

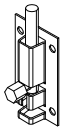
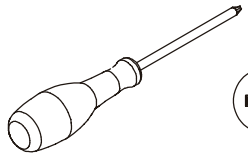

11

<p>C x 4</p>  <p>M3.5x14 mm</p>	<p>J x 1</p>  <p>36x21</p>	 
--	---	---

Fix part(J) to plate 3 using screw(C) as shown.

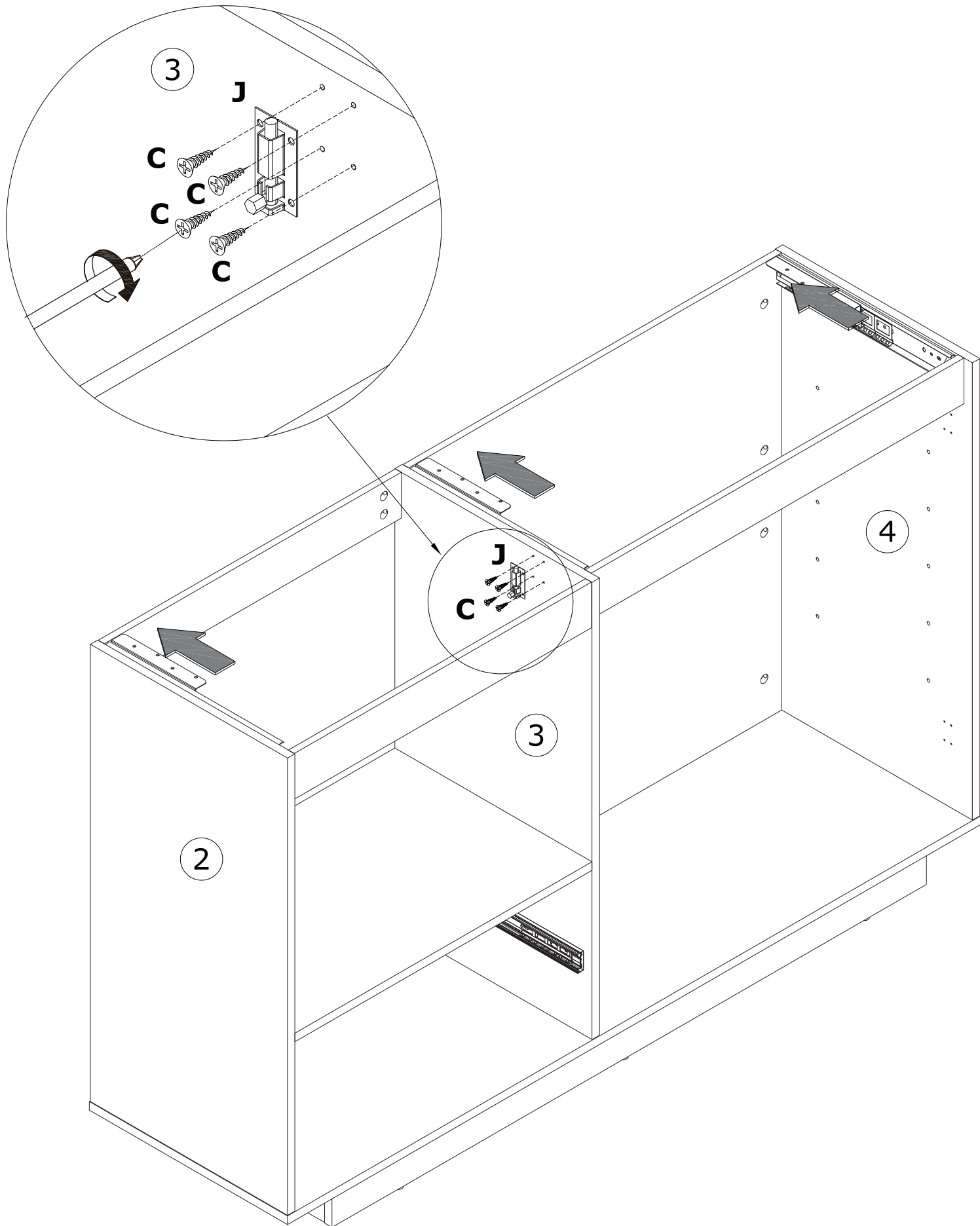

12

C x 6



M3.5x14 mm

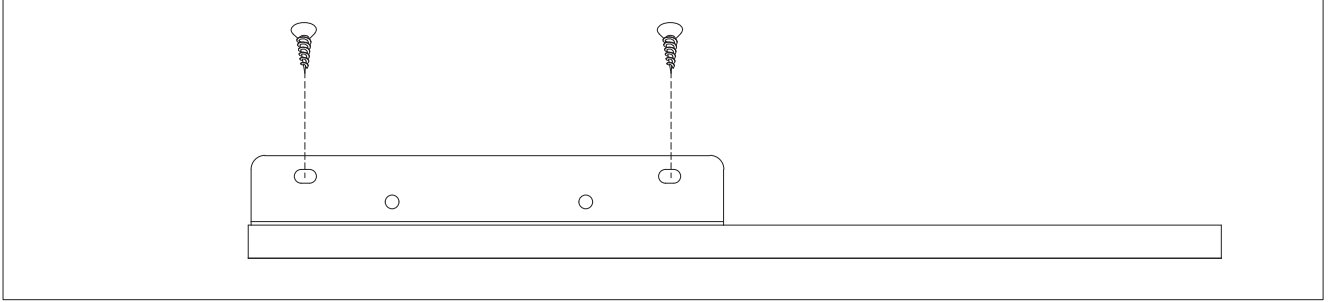
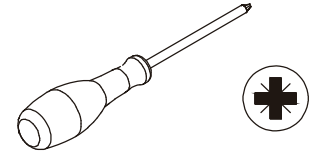

Fix plate 1 to runner 22 using screw(C) as shown.

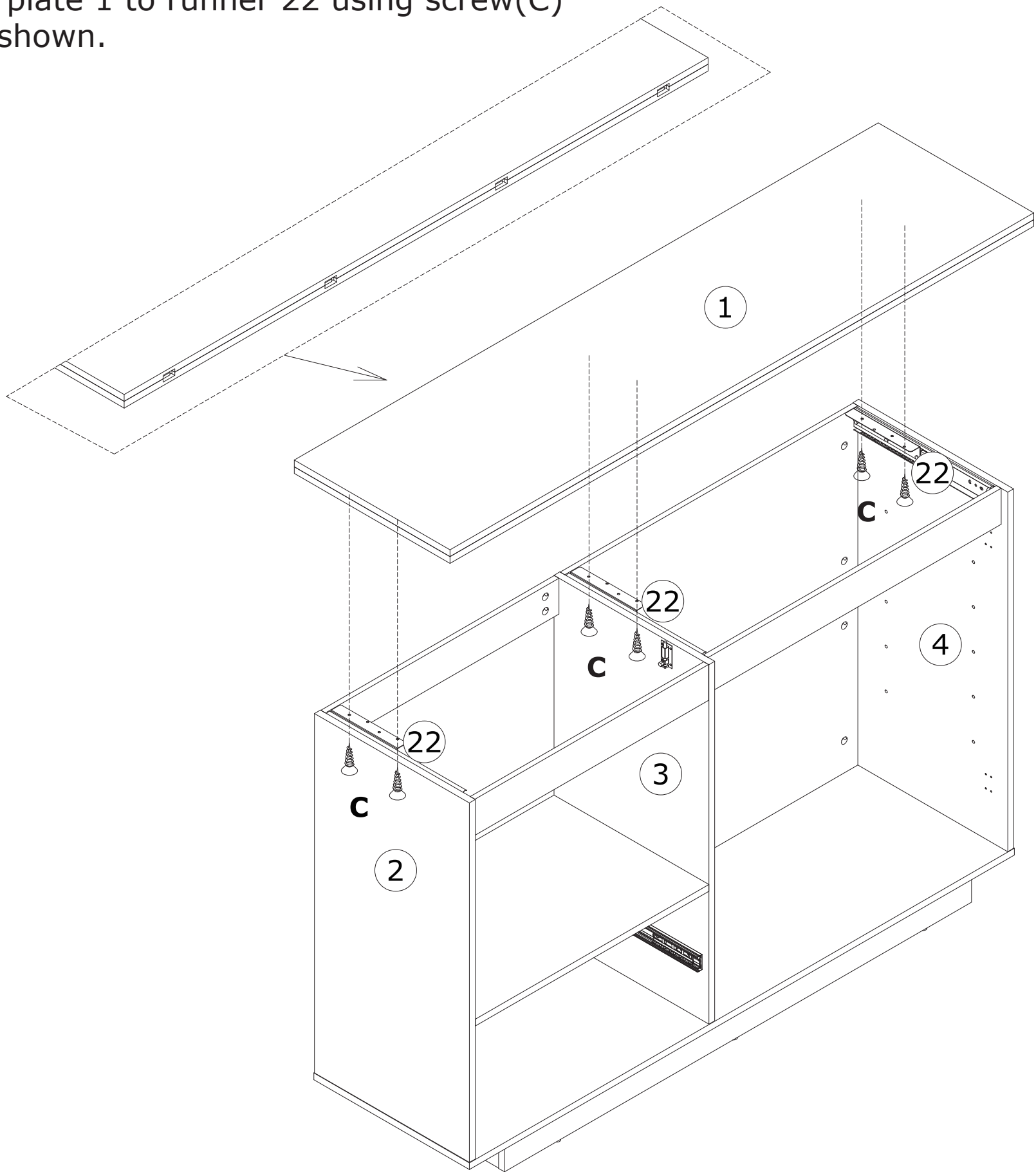

13

F x 8



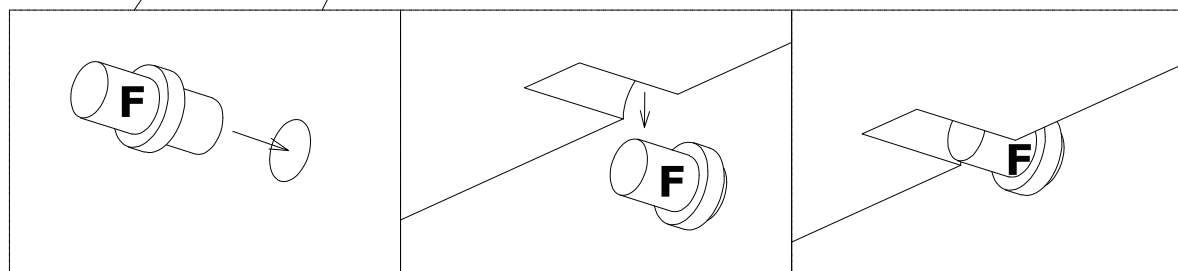
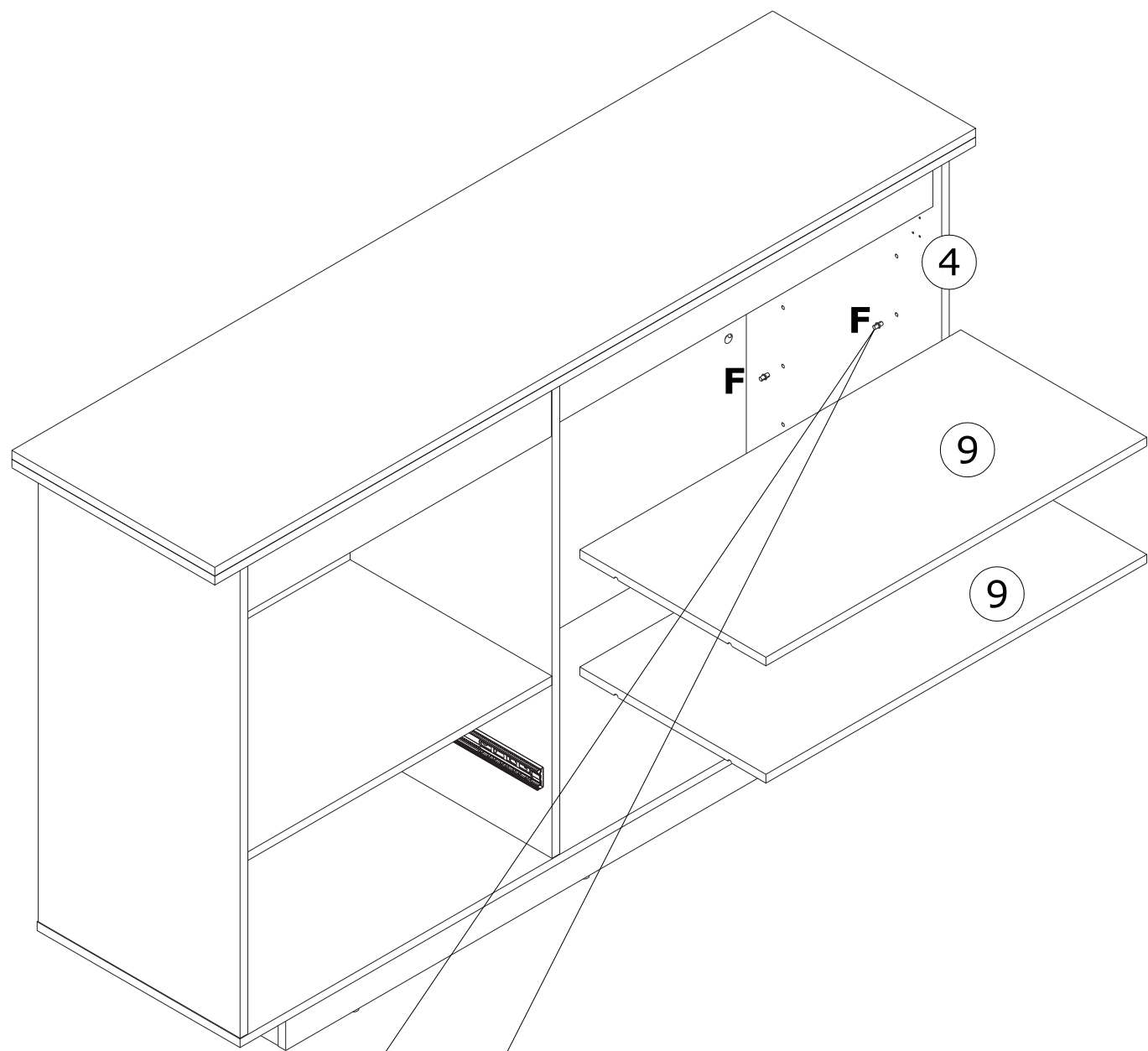

Ø5

Insert part(F) into plate 3 and 4, place shelf 9 in as shown.

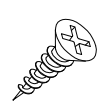
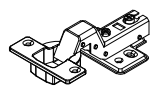
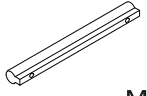
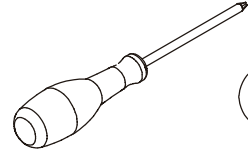

14

<p>C x 8</p>  <p>M3.5x14 mm</p>	<p>G x 4</p>  <p>DW</p>	<p>I x 2</p>  <p>M4*16</p> <p>220-96</p>	 
--	--	---	---

Fix hinge(G) to plate 5 and 6 using screw(C) as shown.
Fix handle(I) to plate 5 and 6 as shown.

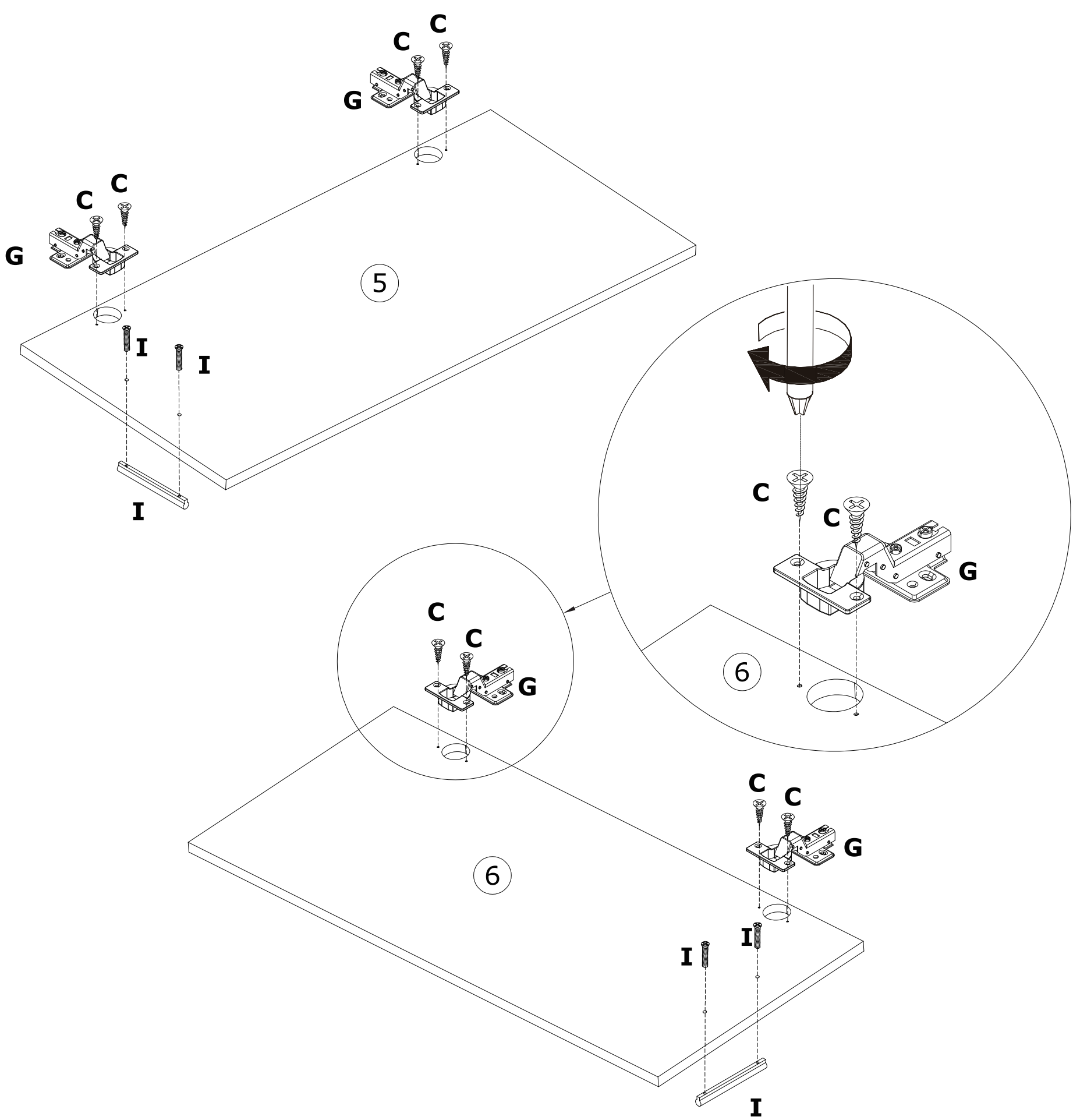

15

C x 16



M3.5x14 mm

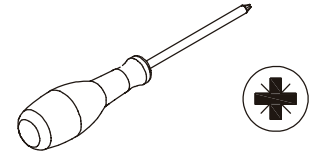

Attach plate 5 to plate 3; plate 6 to plate 4
by fixing hinge with screw(C) as shown.

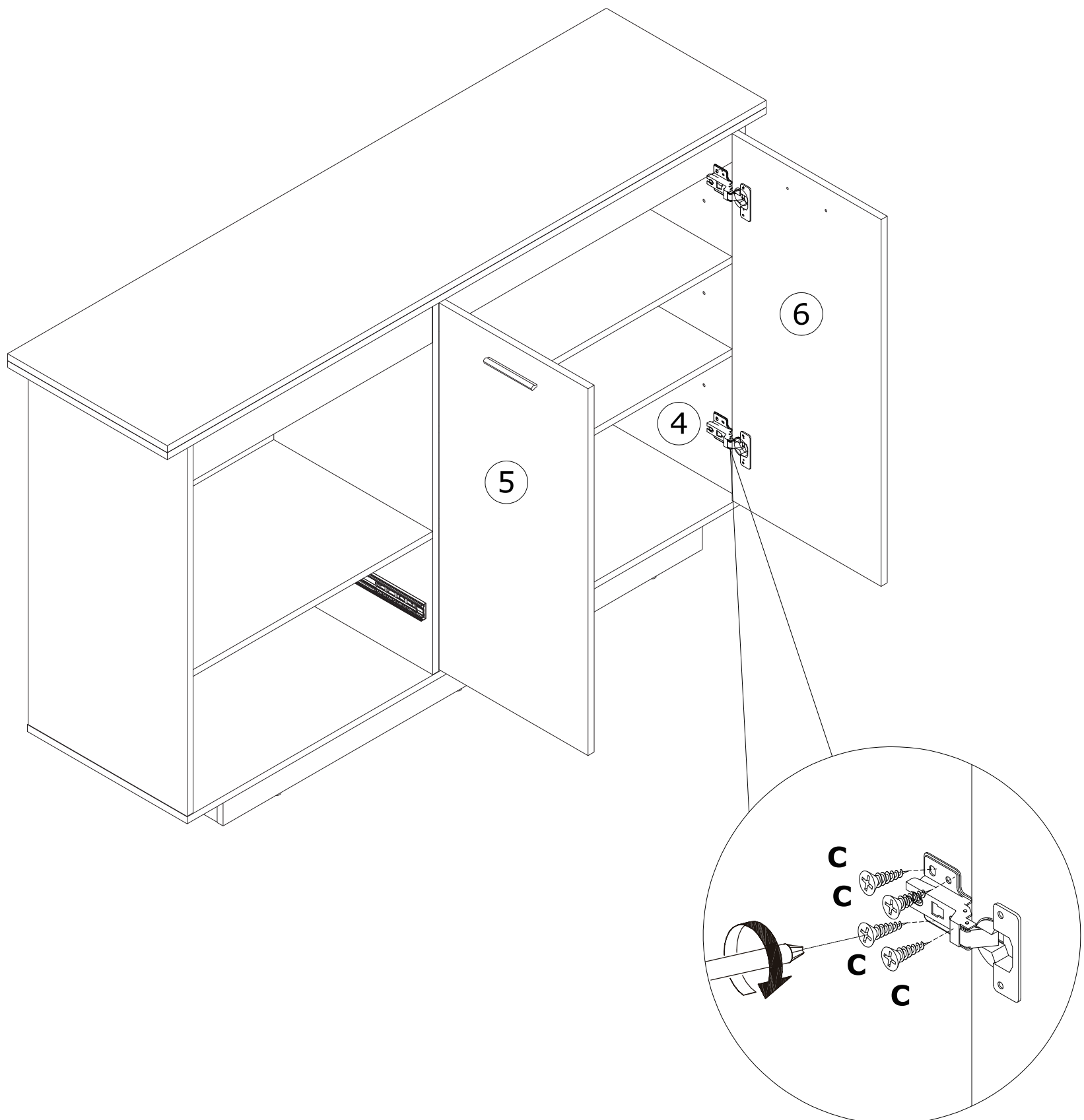

16

H x 4

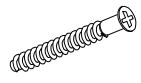

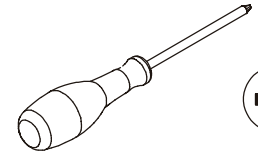

M5x40 mm

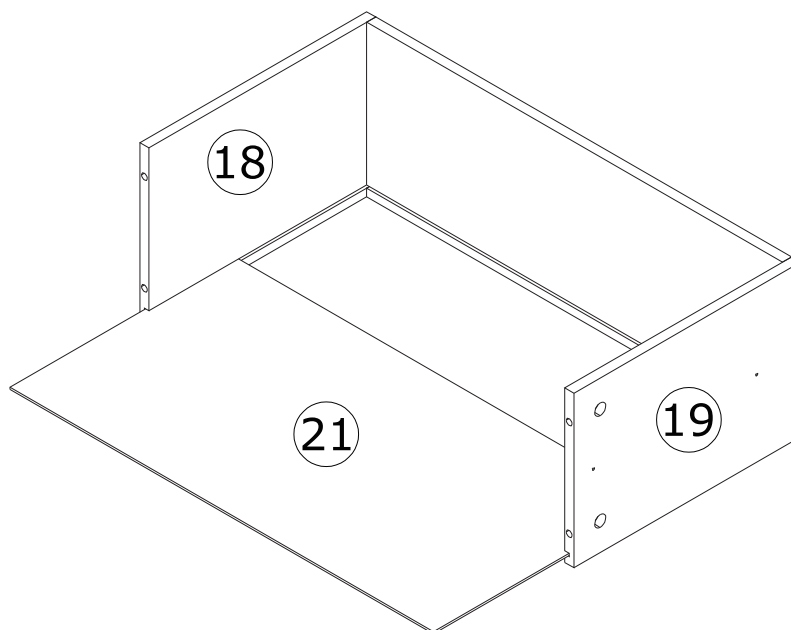
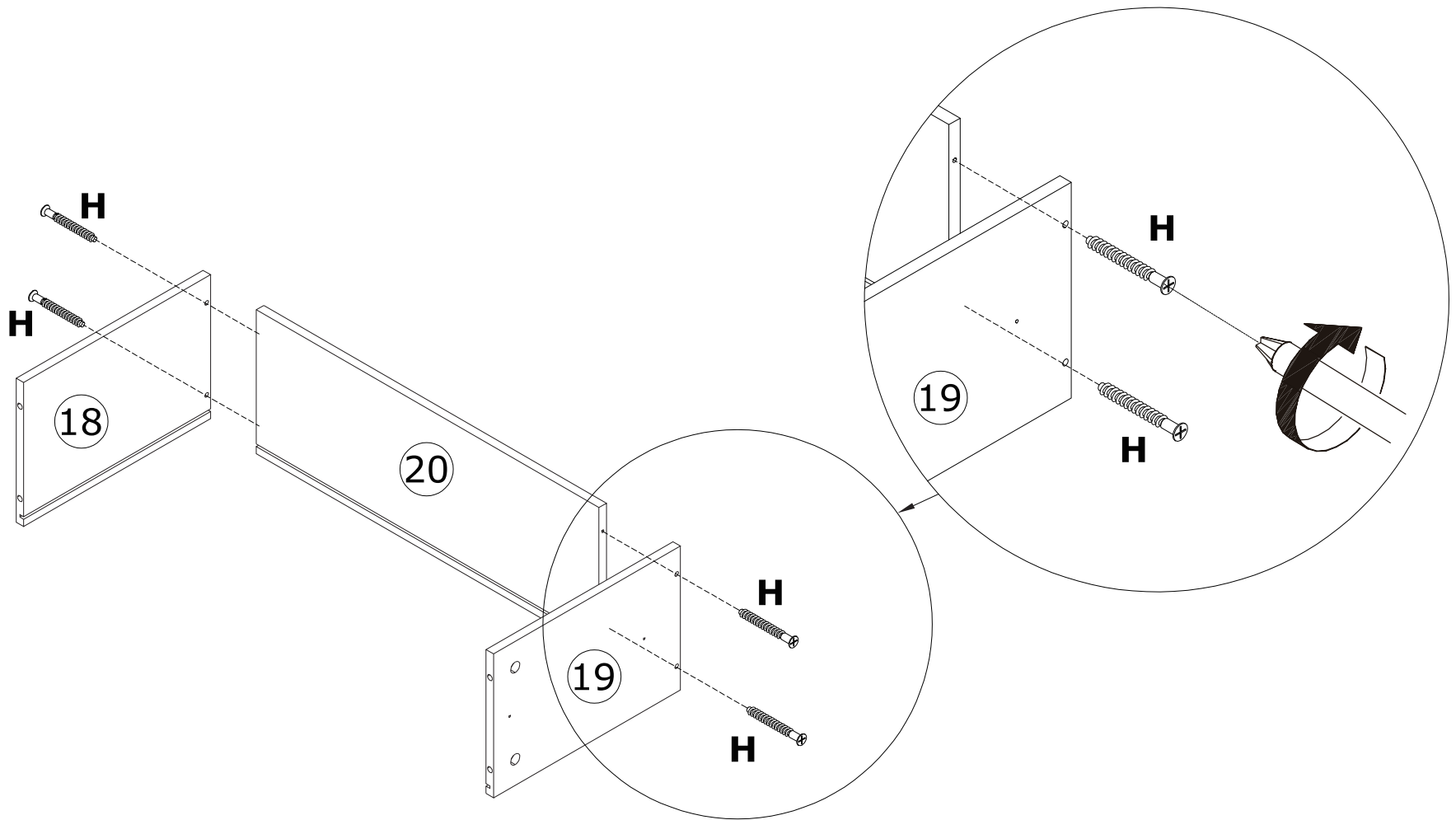

Fix plate 18 and 19 with plate 20 using screw(H) as shown.
Slide plate 21 along grooves as shown.

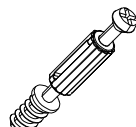

17

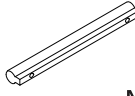
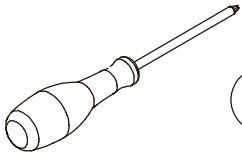
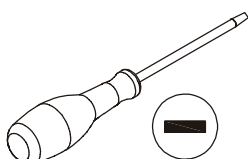
<p>A x 4</p>  <p>M5x42 mm</p>	<p>B x 4</p>  <p>Ø15x10 mm</p>	<p>I x 1</p>  <p>M4*16</p> <p>220-96</p>	 
--	---	---	---

Insert quickfit screw(A) into plate 17 with a screwdriver as shown.
Fix handle(I) to plate 17.

Attach plate 17 to the drawer, put cam lock(B) into holes in plate 18,19
and turn clockwise to tighten as shown.

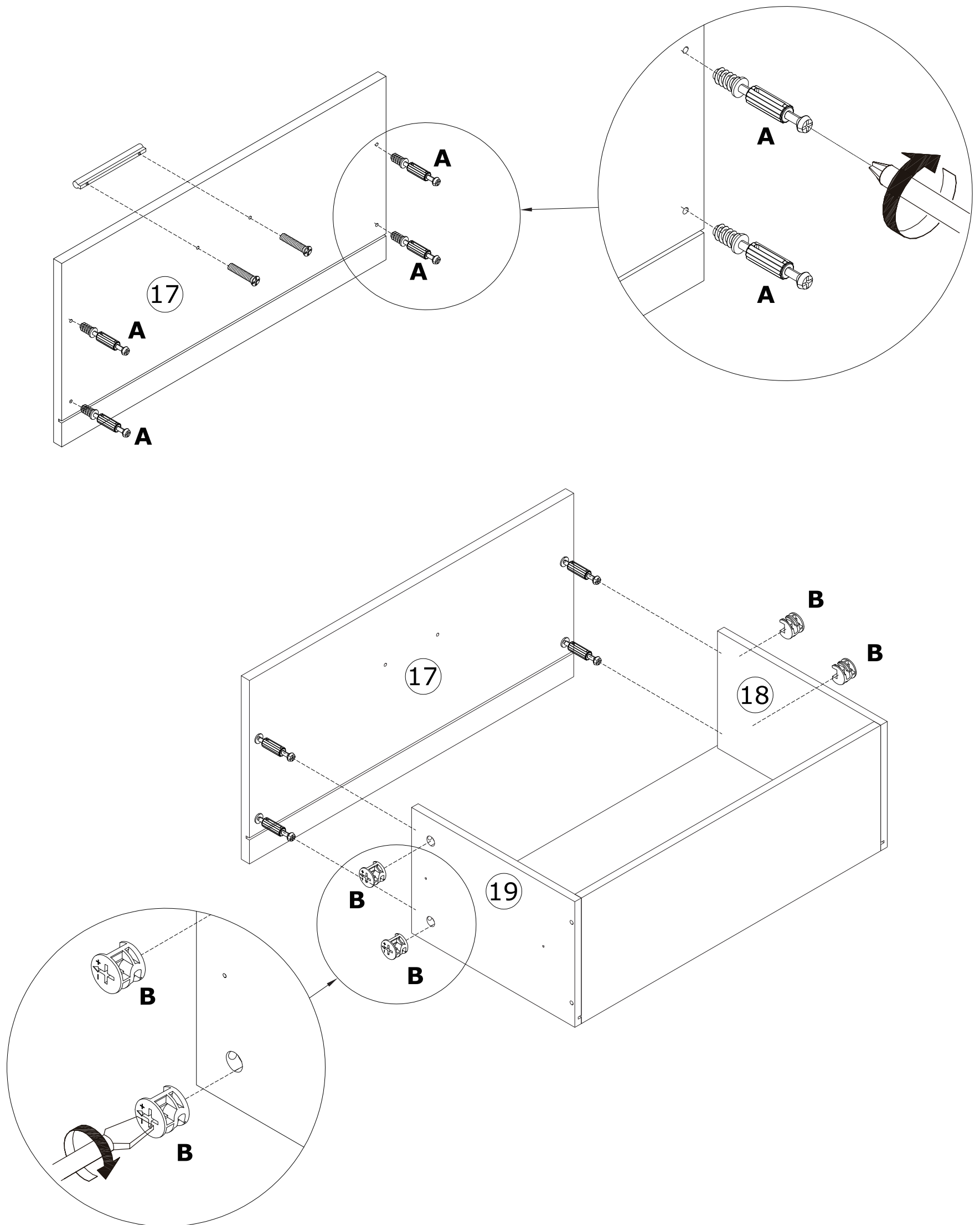

18

K x 4



M3.5x12 mm

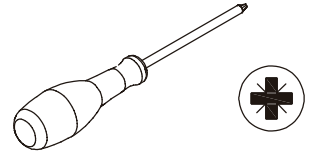

Fix runner 23 to plate 18 and 19 using screw(K) as shown.

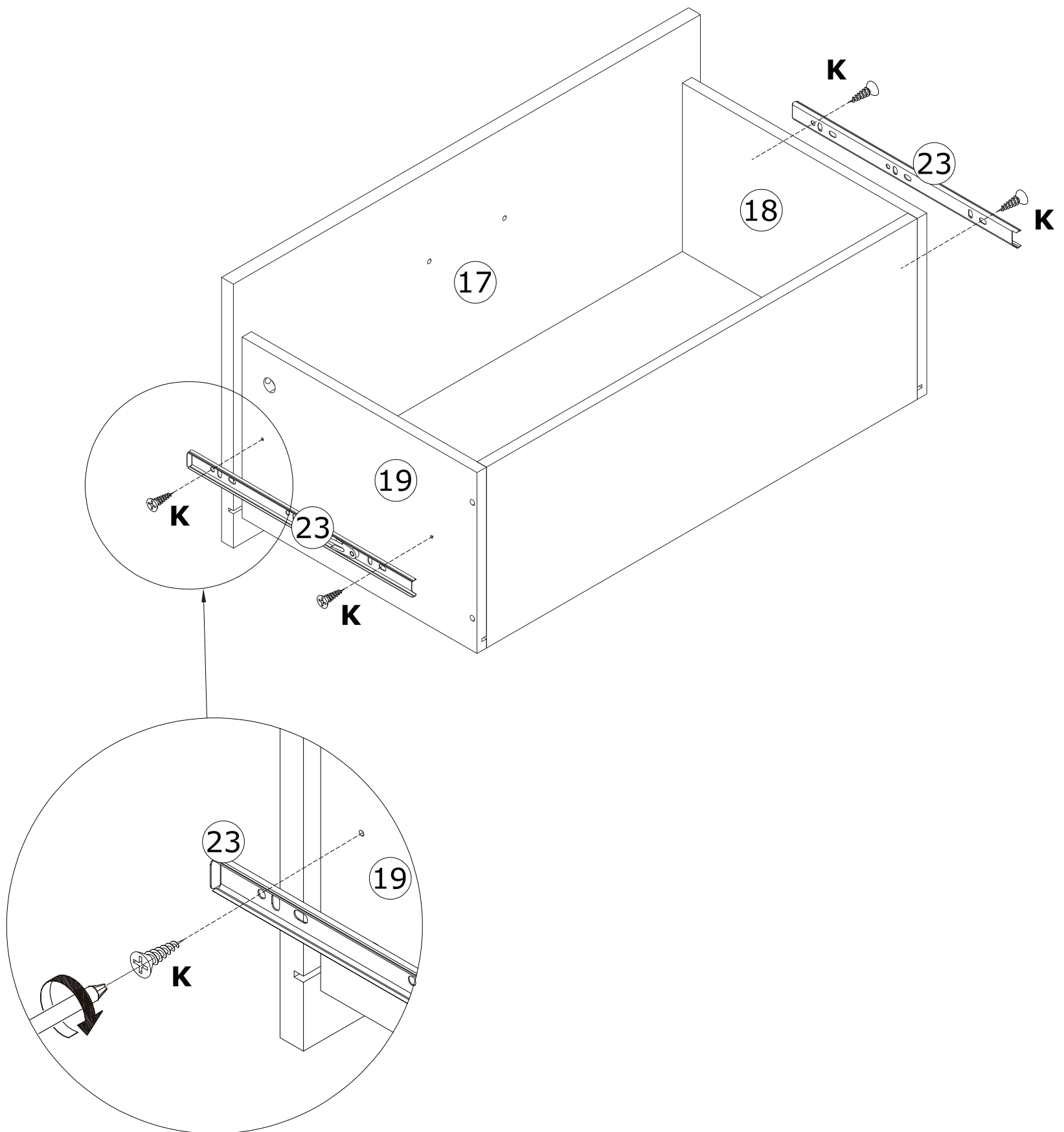

19

Align rails, slide the drawer.
Lift part(J) upward to fix the plate 1 to prevent the table from sliding.

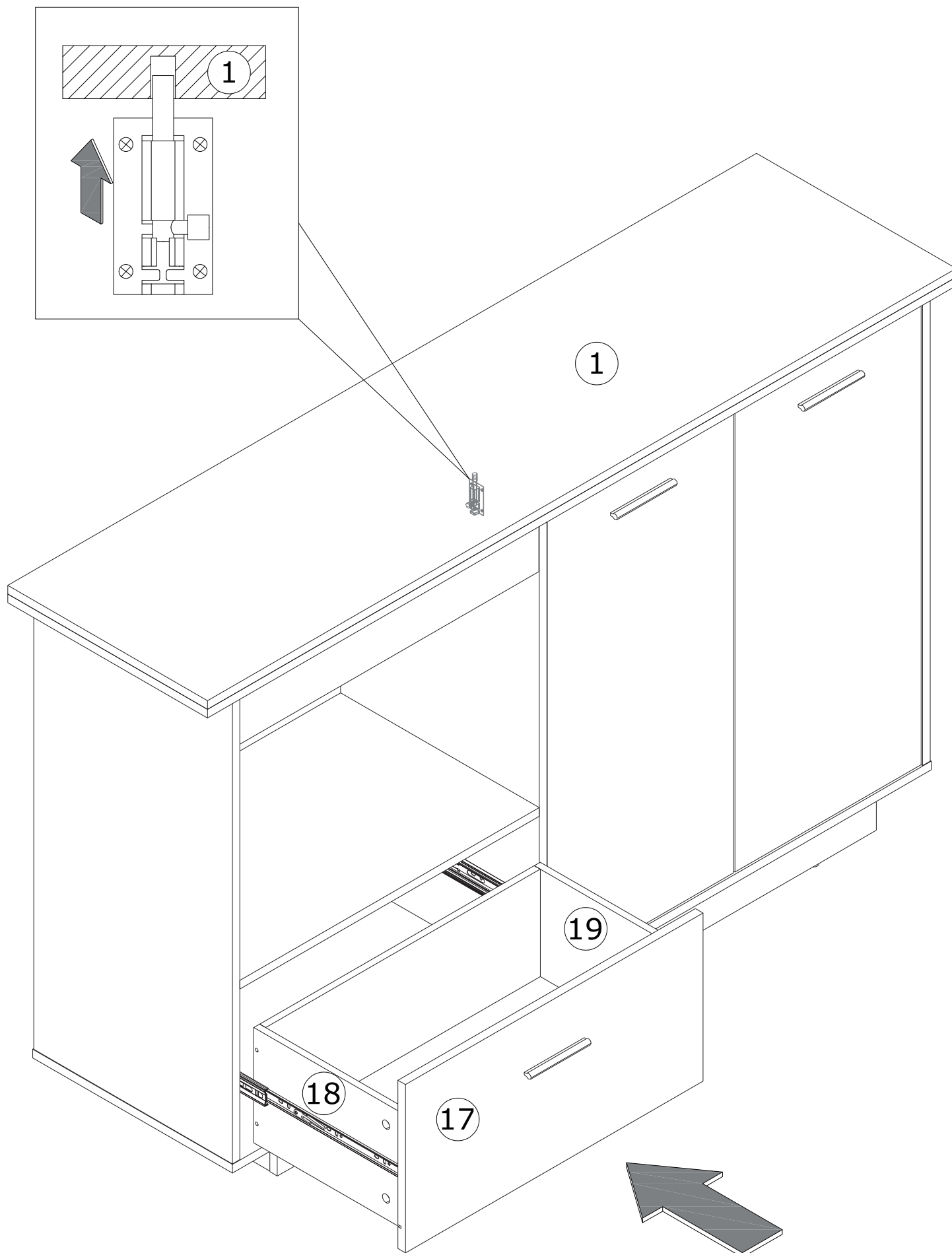

20

Do not open the table without support,
otherwise the hinge will break.

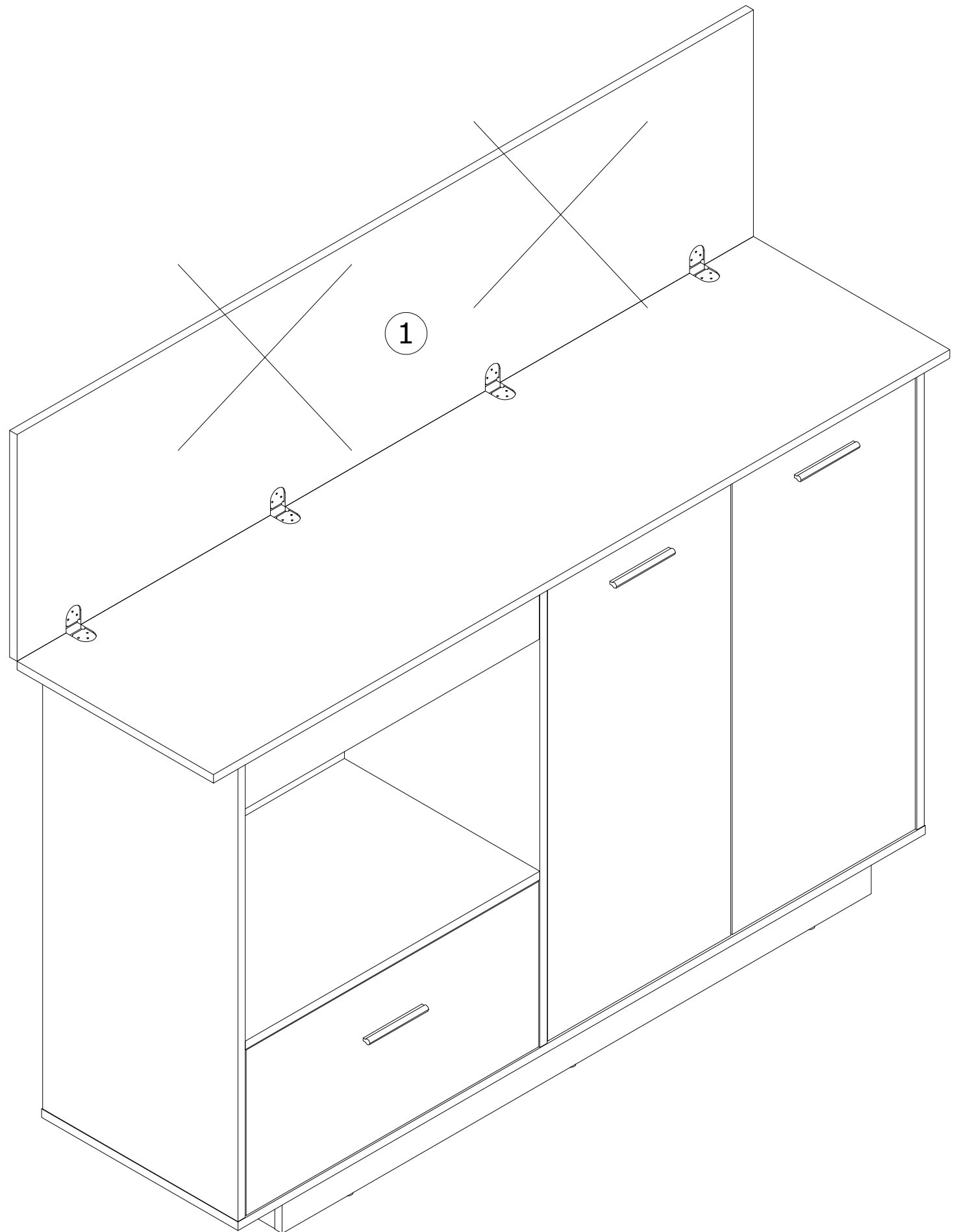

21

Loosen part(J) downward, the table can move forward, and then spread out the table for use.

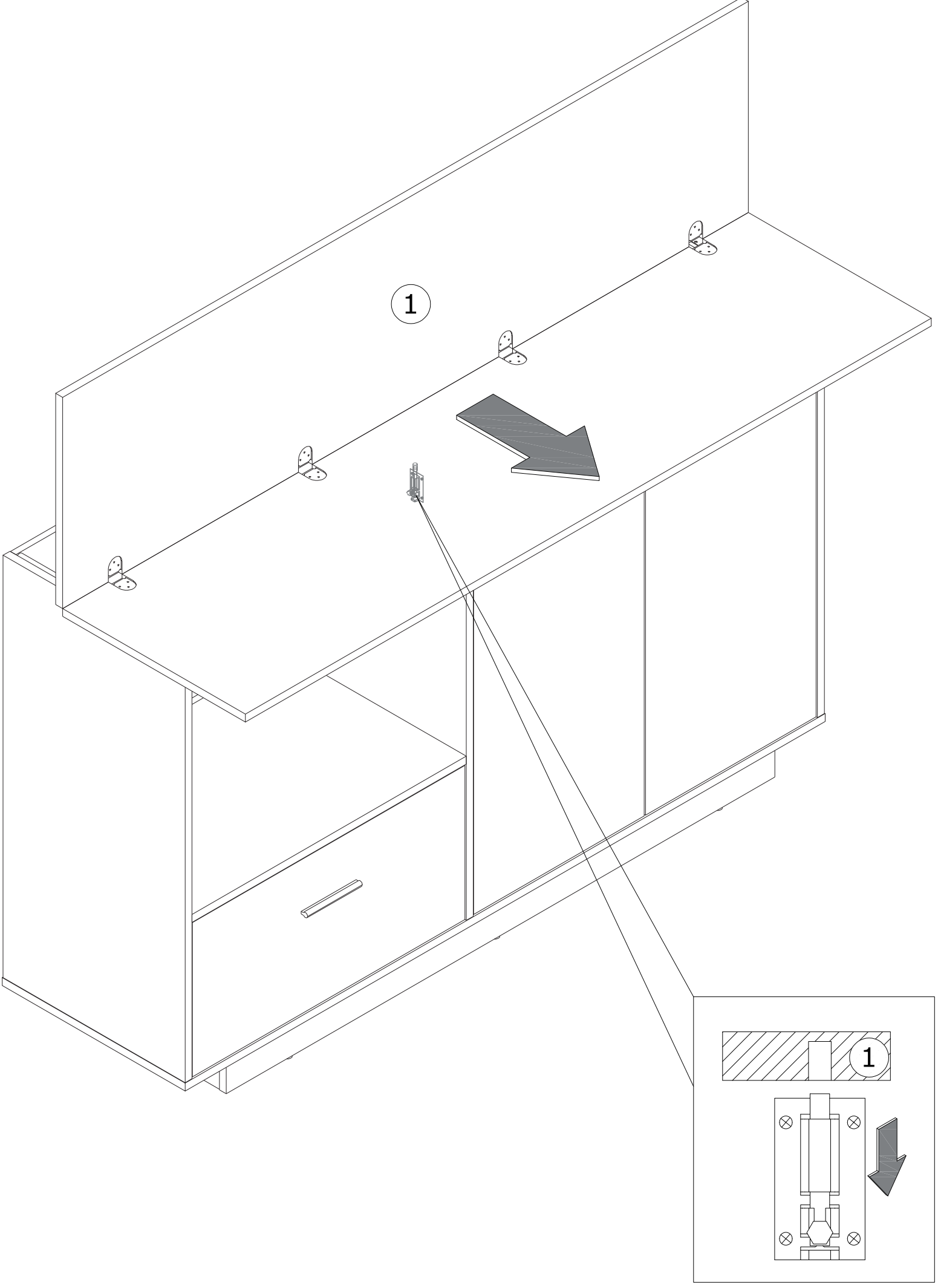

22

Lift part(J) upward to fix the plate 1.

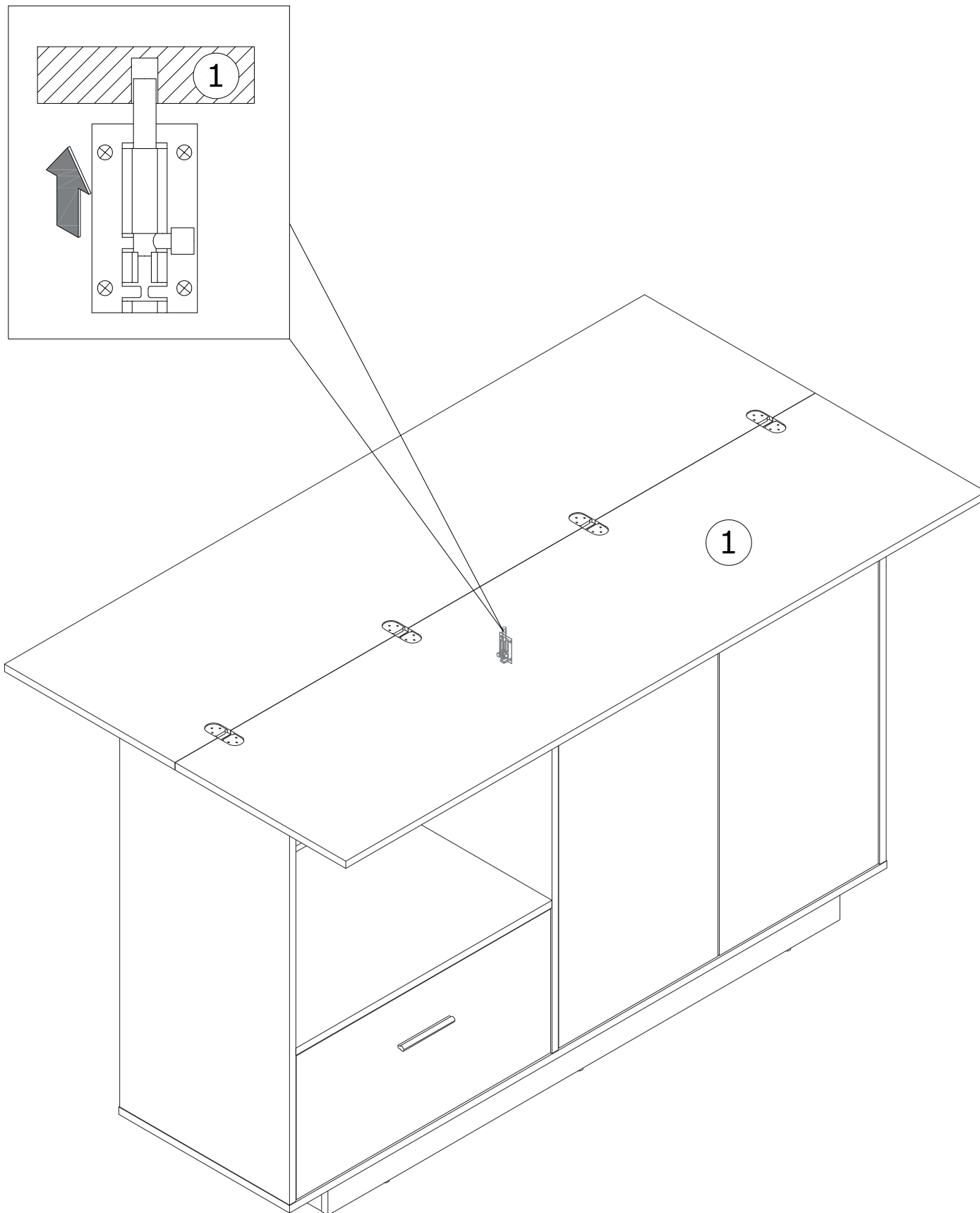

If there is misalignment after you install,
adjust the screw to the best condition

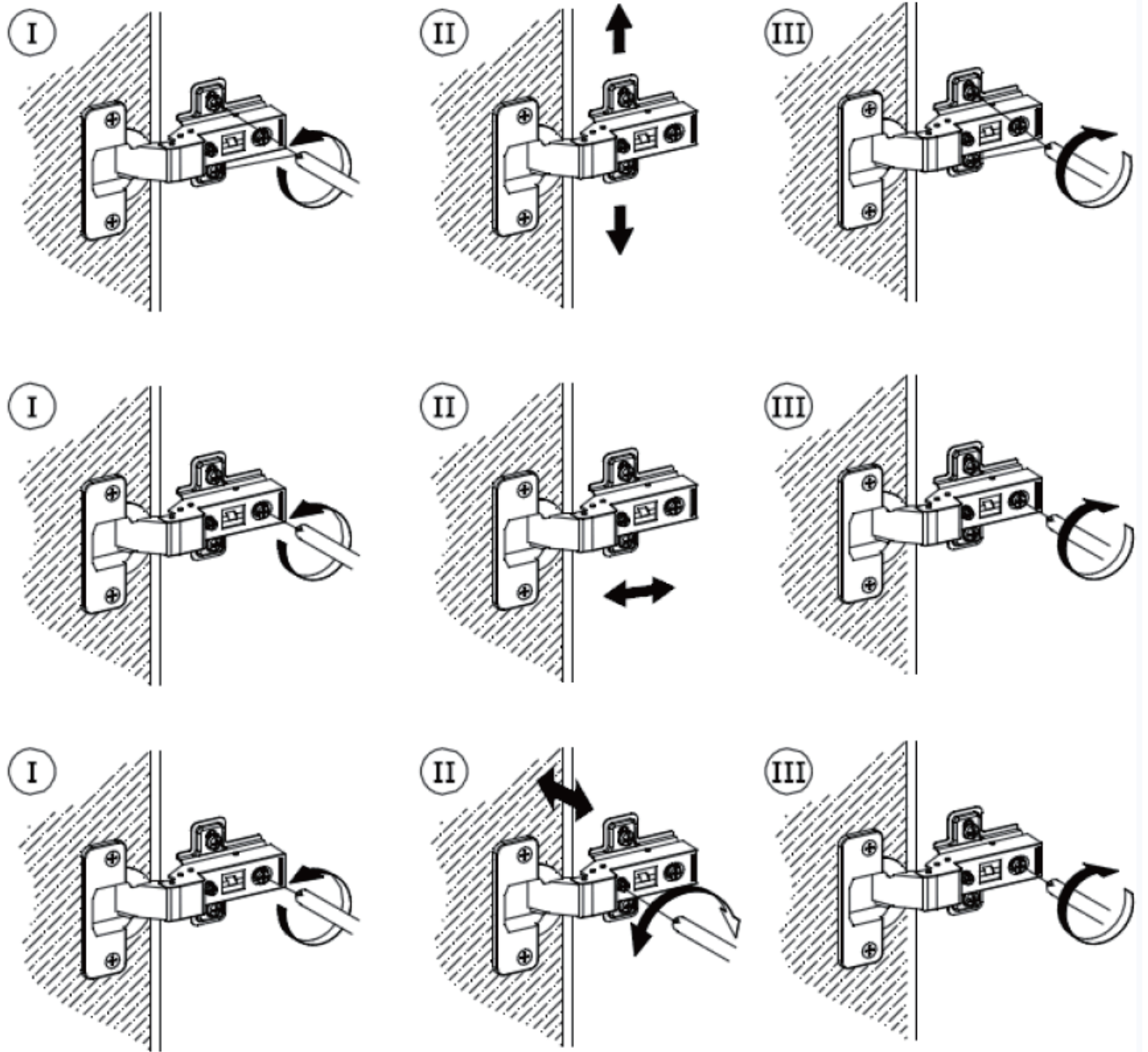
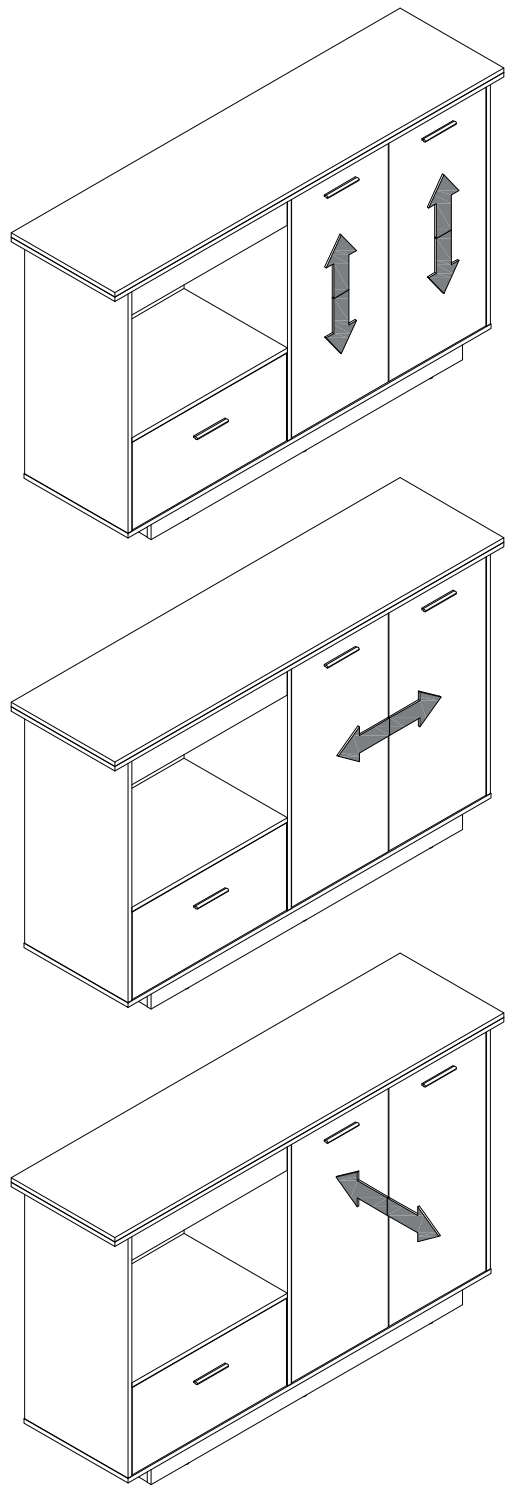

WARRANTY

WARRANTY CLAIMS

- There is a 30-day warranty for broken furniture or any other problems that do not work properly. The warranty will start from the date of purchase which must be verified by proof of purchase.
- Before making a claim, we may be able to answer your query, simply call us. Please leave your purchase order number, along with some details of the problem, if you want a replacement part. We will arrange within 48 hours. If there is out of stock, we will reply with a shipping date.
- The product must be used in accordance with the instructions provided. For health reasons.
- For other reasons, if the furniture needs to be returned, it must be cleaned and dried and operated within 30 days of receipt.

Type of Warranty Claim

- Failure to follow the furniture instructions will invalidate the warranty. Attention please.
- Does not include damage during installation, but includes damage during transportation.

Scope of responsibility

- Shall not bear any responsibility for misuse or user damage and / or loss of parts during the installation of furniture.
- After using, the damage and scratches of the furniture are not covered by the warranty.

The Warranty Relates to All Bought in The Us and Covers The Following Areas

- Sheet parts: 1 month from the date of purchase.
- Electrical parts: 1 month from the date of purchase.

RETURNS

CHANGED YOUR MIND AND NEED TO RETURN YOU ITEM?

PLEASE FOLLOW THE BELOW INSTRUCTIONS:

- If you have purchased and have simply changed your mind, follow the retailer's instructions for returns.

DEFECTIVE ITEMS

- If your item is defective in any way, i.e. it doesn't work but you can't identify why, in the first instance, please call us.

DAMAGED ITEMS

- If you receive an order with obvious shipping damage from the retailer, then we suggest the delivery is refused. If the delivery has been accepted and then shipping damage is found, please follow the specific instructions advised by the retailer.
In all circumstances please save all packaging material and paperwork for the order. Please be aware that if you dispose of packaging material or attempt to return the merchandise without contacting the fulfiller, you jeopardise your chances of making a claim, and you may not receive a credit for the return.