

Storage Bed

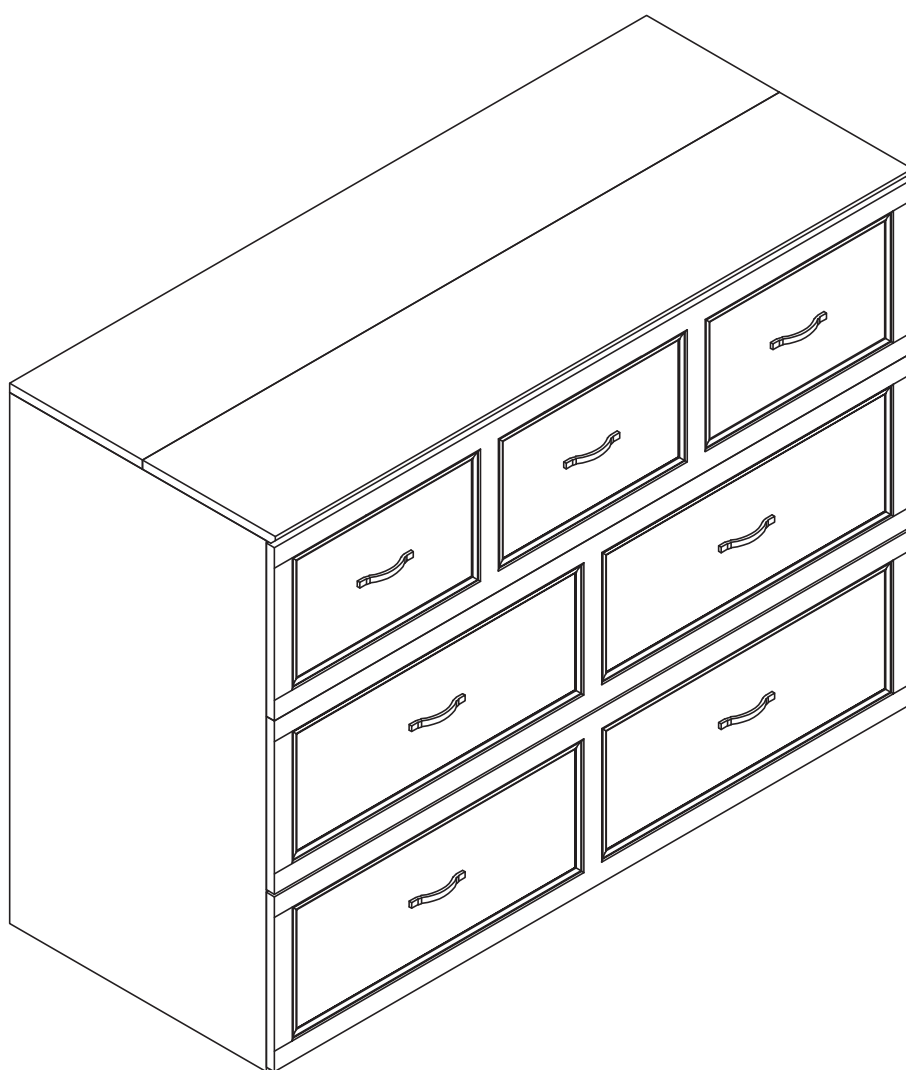

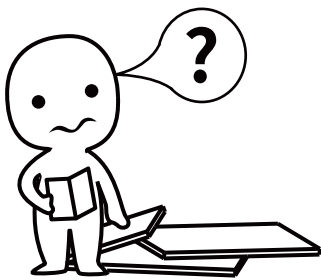

IMPORTANT INFORMATION!

please read the entire manual before starting to assemble and/or using this product. follow the manual thoroughly and keep it for further reference.

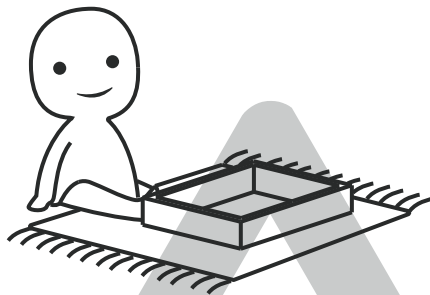
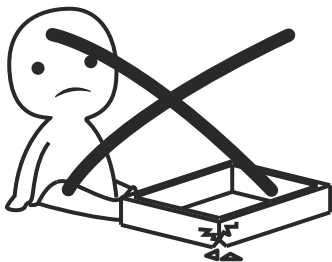

AVOID SCRATCHES!

In order to avoid scratching this furniture should be assembled on a soft layer- could be a rug.

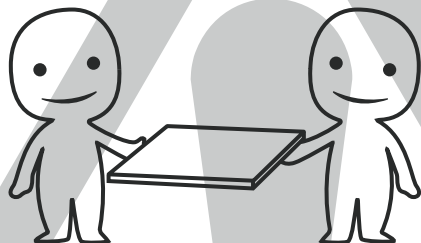

IMPROVE EFFICIENCY !

Try to find a partner to install with you, which can speed up the installation efficiency and shorten the time.

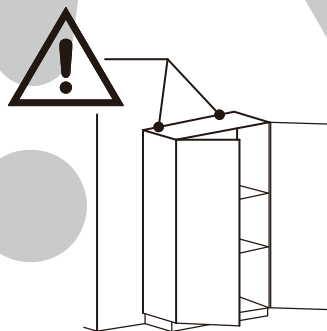
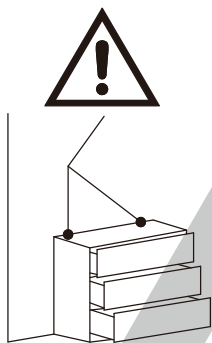

ANTI-TOPPLE WARNING !

Overturnd furniture can cause serious or fatal crush injuries. To prevent tipping over, be sure to use the wall attachment, if not included with this product. Please purchase the wall attachment that fit your wall. If unsure, seek professional advice. Please read and follow each step of the instructions carefully.

IMPORTANT !

It is important that any product which is assembled using any kind of screw is re-tightened 2 weeks after assembly, and once every 3 months - in order to assure stability through-out the lifespan of the product.

For regular maintenance and cleaning of the product, for the frame, please use a rag dipped in neutral detergent to fully wipe it, and then dry it with a clean rag. For glass materials, wipe with a rag dampened with water glass cleaner, and then dry with a dry rag.

Do not use an electric screwdriver, and do not use too much force when installing, because the board is easy to break.

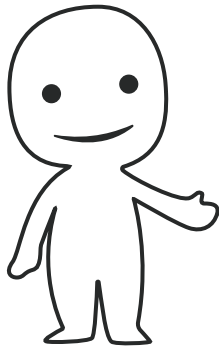

Please prepare the following tools

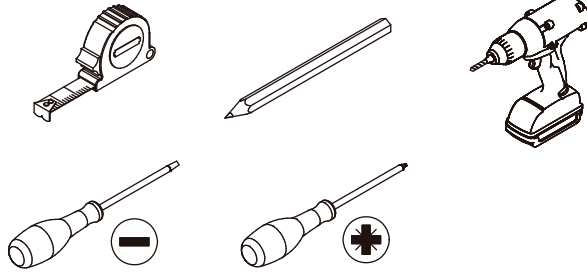

When installing, please carefully confirm whether each screw corresponds to the manual, accessories with similar shapes can be distinguished by size

A x 32(+2)

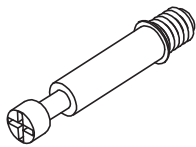

Ø 6 x 35 mm

B x 38(+2)



Ø 15 x 10 mm

C x 40(+4)

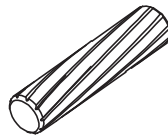

Ø 6 x 30 mm

D x 8

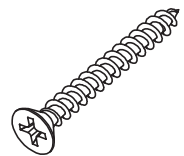

Ø 4 x 35 mm

E x 170(+5)



Ø 3.5 x 12 mm

F x 1

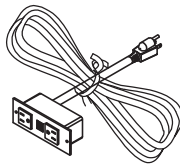

G x 2



Ø 3.5 x 12 mm

H x 3

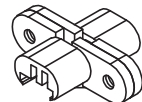

J x 12

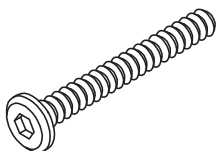

Ø 6 x 40 mm

K x 18



L x 1

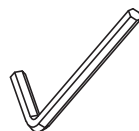

M4 mm

M x 8

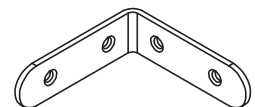

N x 8

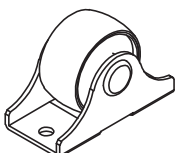

P x 6

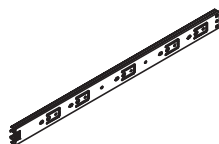

L=450 mm

Q x 7



Ø 4 x 30 mm

R x 7



96 mm

S x 14



T x 18(+2)



Ø3 x 16 mm

U x 18

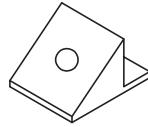

V x 16

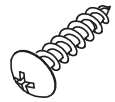

Ø4 x 20 mm

W x 4



X x 6

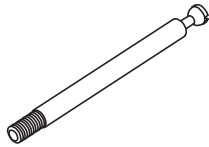

Y x 4

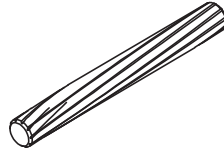

Ø8 x 60 mm

Z x 4

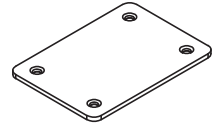

AS x 2

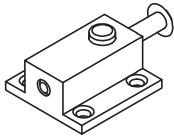

BS x 8

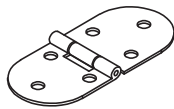

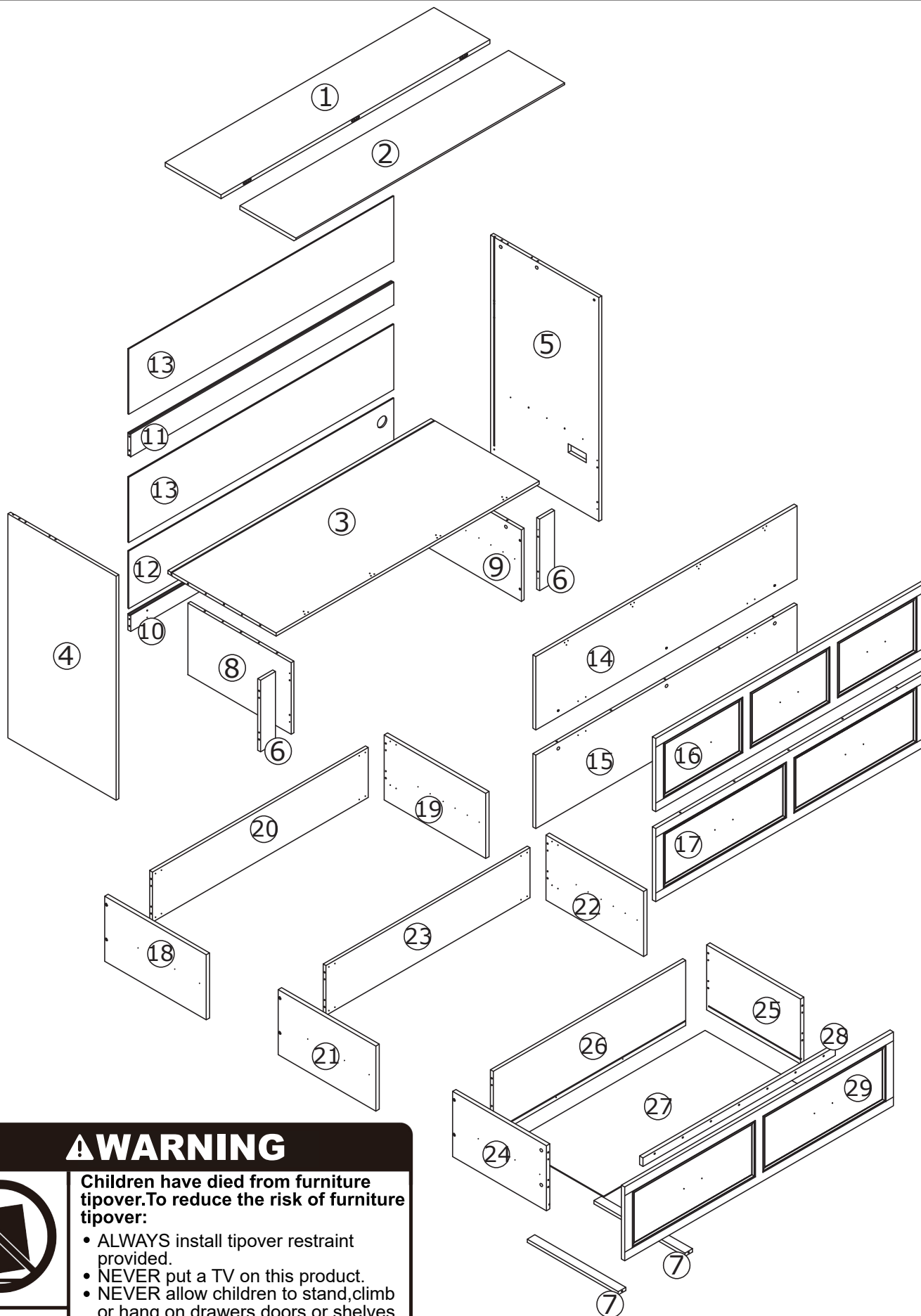

⚠ WARNING



Children have died from furniture tipover. To reduce the risk of furniture tipover:

- ALWAYS install tipover restraint provided.
- NEVER put a TV on this product.
- NEVER allow children to stand, climb or hang on drawers, doors, or shelves.
- NEVER open more than one drawer at a time.
- Place heaviest items in the lowest drawers.

*This is a permanent label.
Do not remove!*

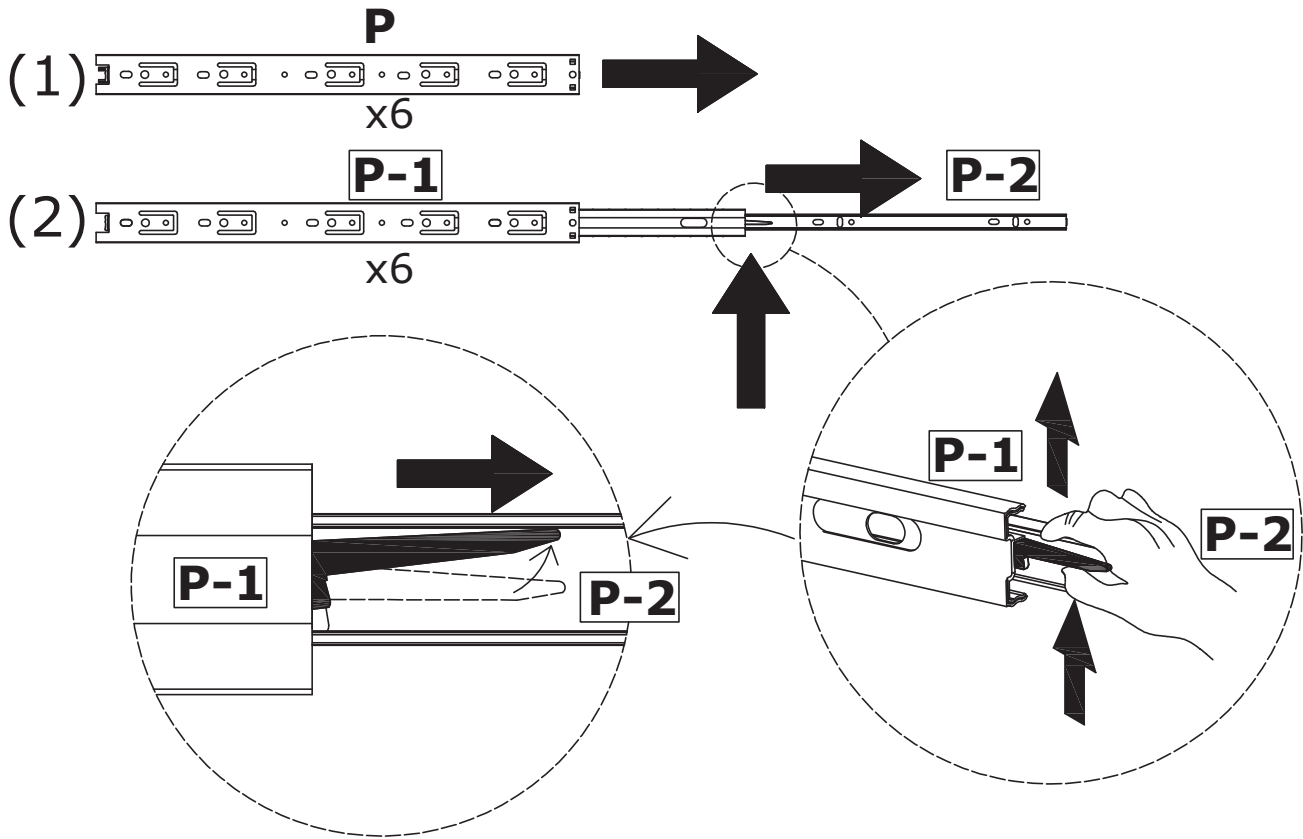

Move the black paddle upward and pull out (P-2) to the right.

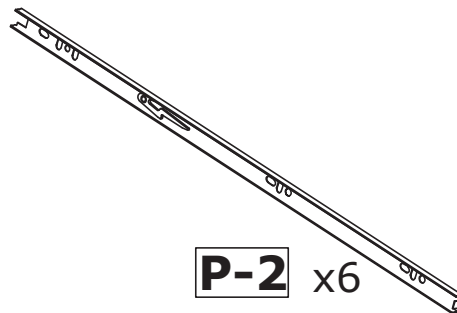
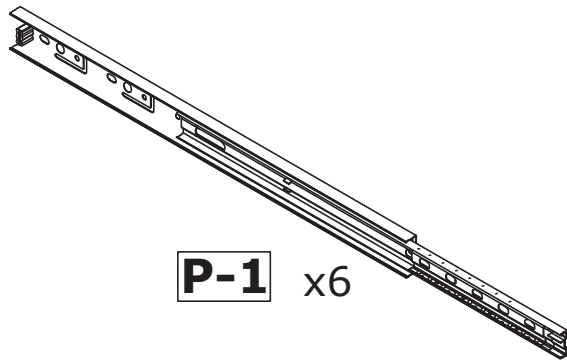
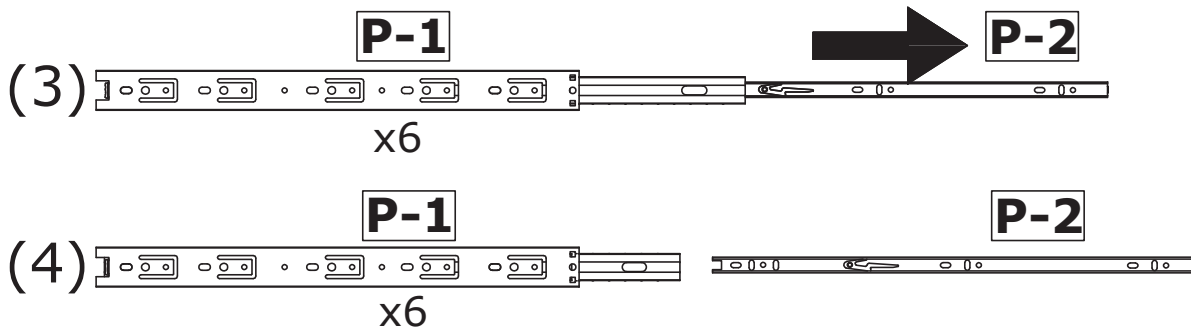

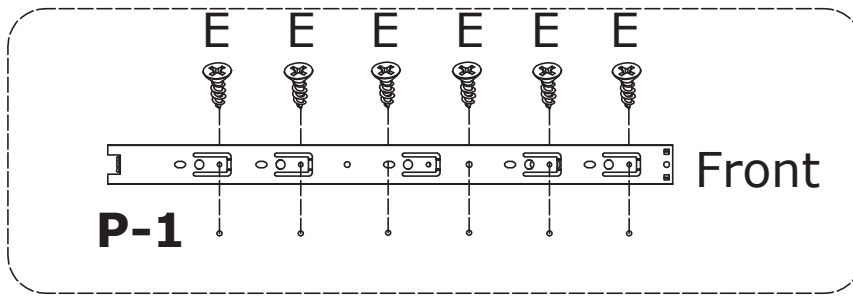

(1)

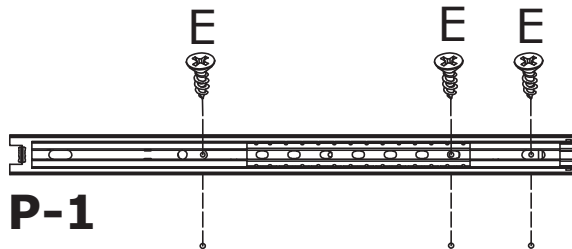

Refer to the figure above,
lock the first, second and fifth holes first

(2)

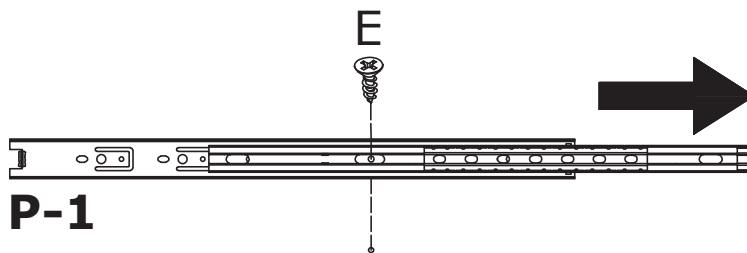

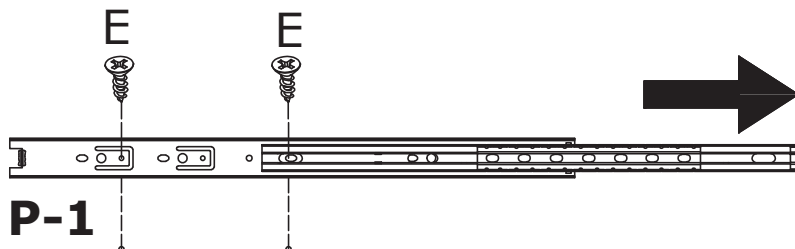

Refer to the figure above,
open the second section and lock the third hole

(3)



Refer to the figure above,
Continue to open the second section and
lock the fourth and sixth holes

1

<p>C x 6</p>  <p>∅ 6 x 30 mm</p>	<p>(P-1) x 2</p>  <p>L=450mm</p>	<p>E x 12</p>  <p>∅ 3.5 x 12 mm</p>	
---	---	--	---

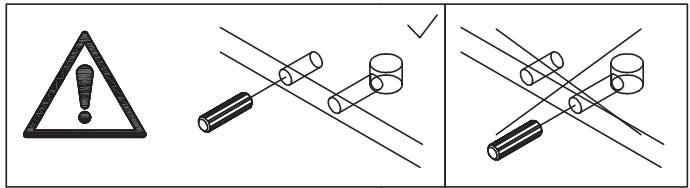

See page 7 for the installation method of slide rail (P-1)

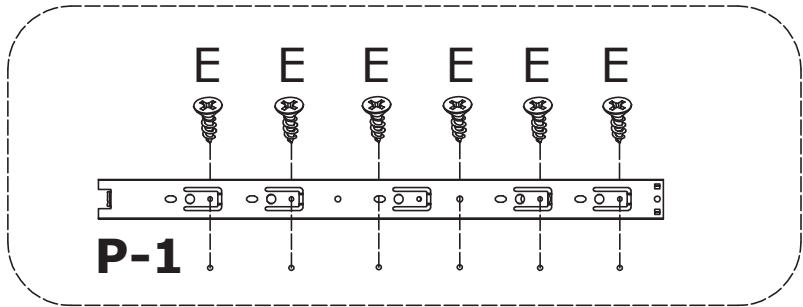

Separate glide into two parts at first(in page 6).

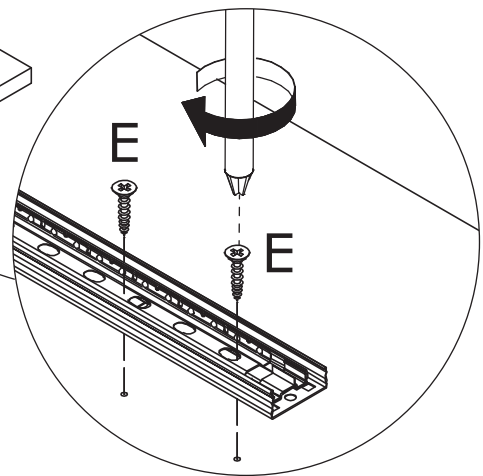
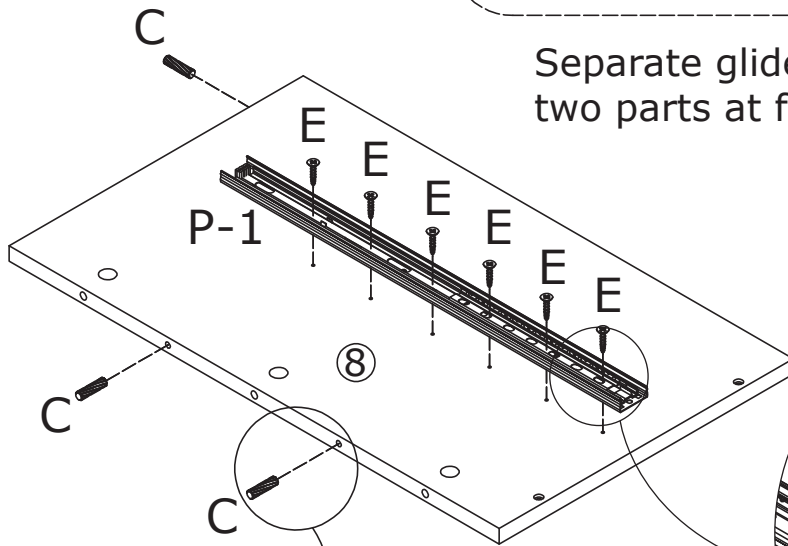

Fix slide rail(P-1) to plate 8 and 9 with screw(E) as shown.

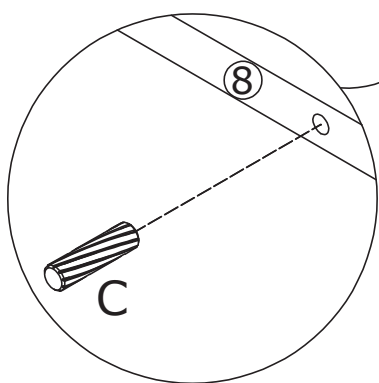

Insert wooden dowel(C) into corresponding holes in plate 8 and 9 at first.

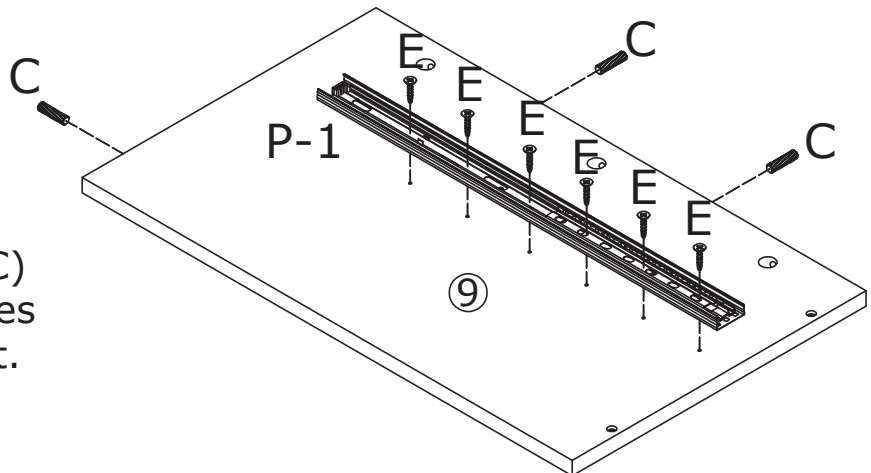

2

C x 8  ∅ 6 x 30 mm	
---	--

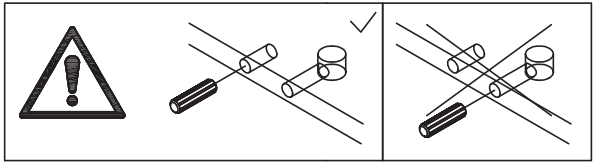

Insert wooden dowel(C)
into corresponding holes
in two plate 6 at first.

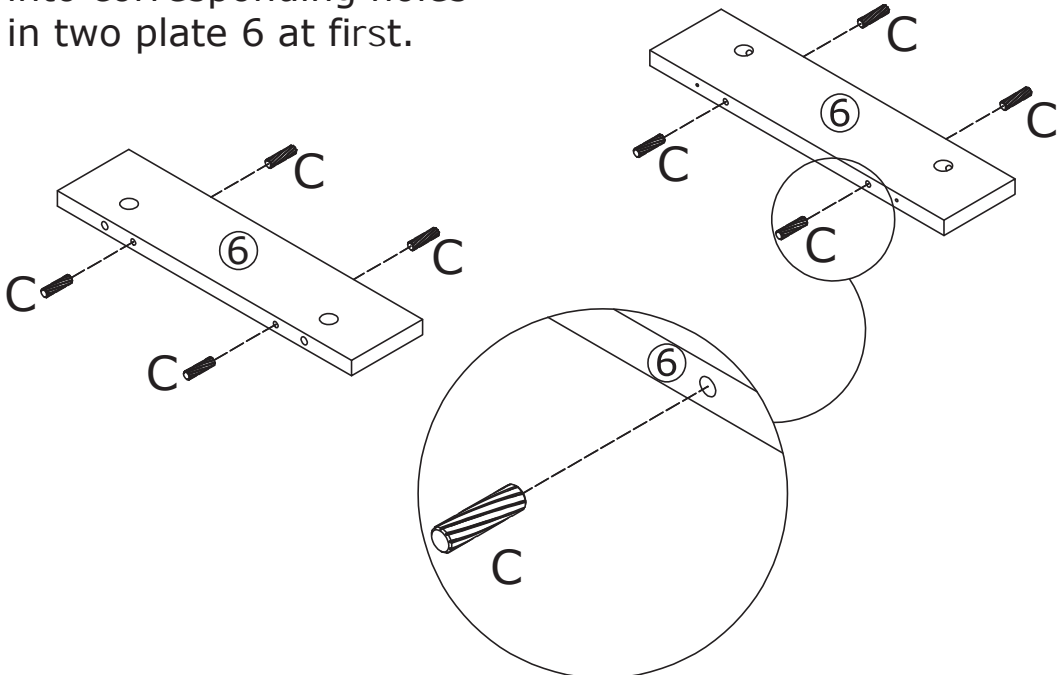

3

D x 2  ∅ 4 x 35 mm	
---	---

Attach plate 6 to plate 8
and fix with screw(D) as shown.

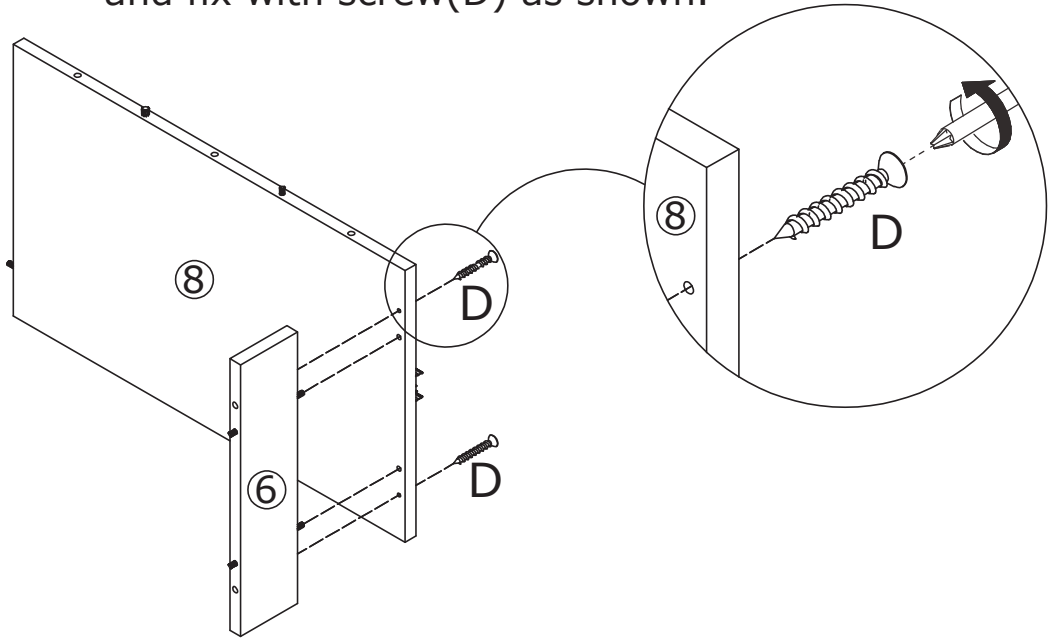

4



Attach plate 6 to plate 9 and fix with screw(D) as shown.

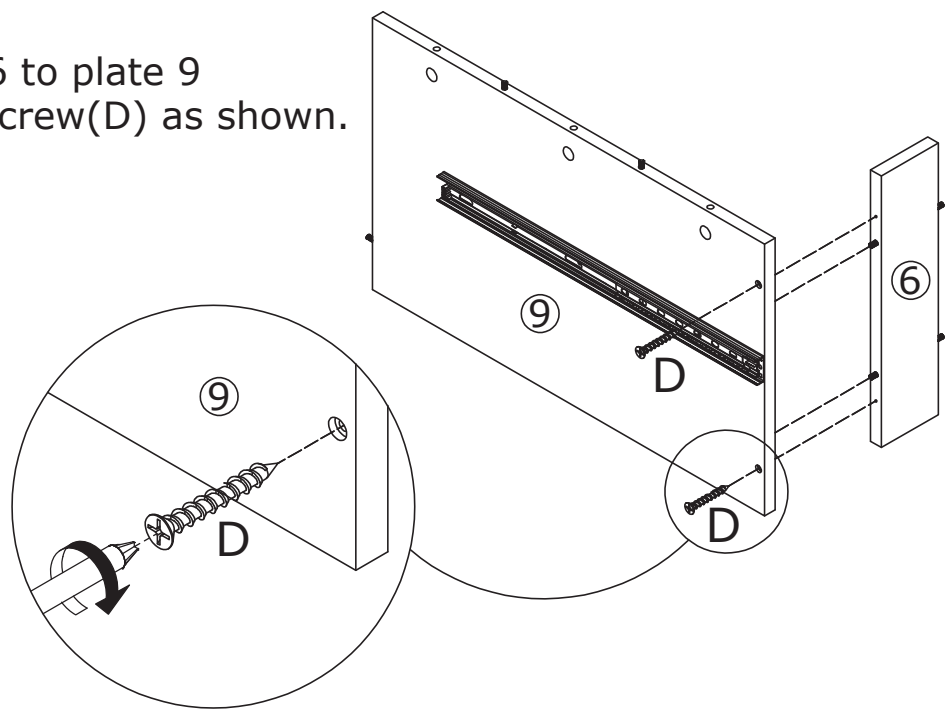

5



Insert quickfit screw(A) into corresponding holes in plate 3 with a screwdriver as shown.

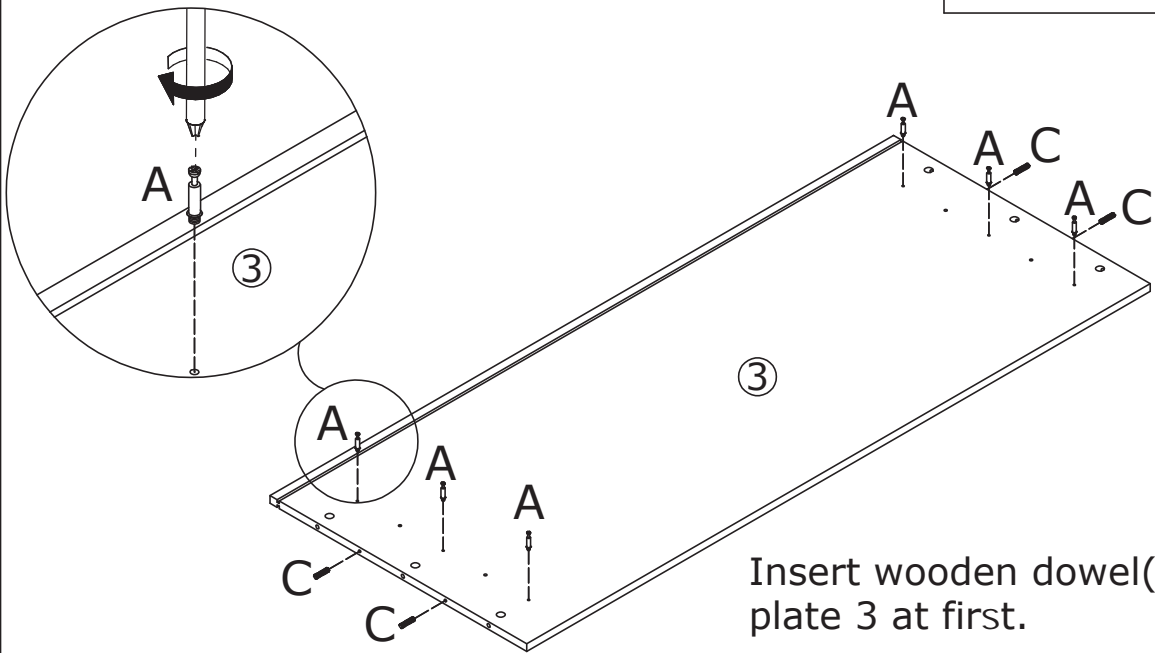
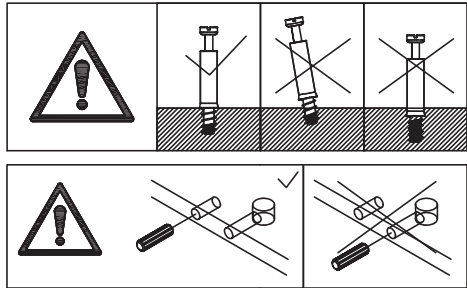

Insert wooden dowel(C) into plate 3 at first.

6



B x 6

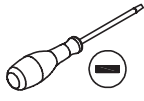

Ø 15 x 10 mm

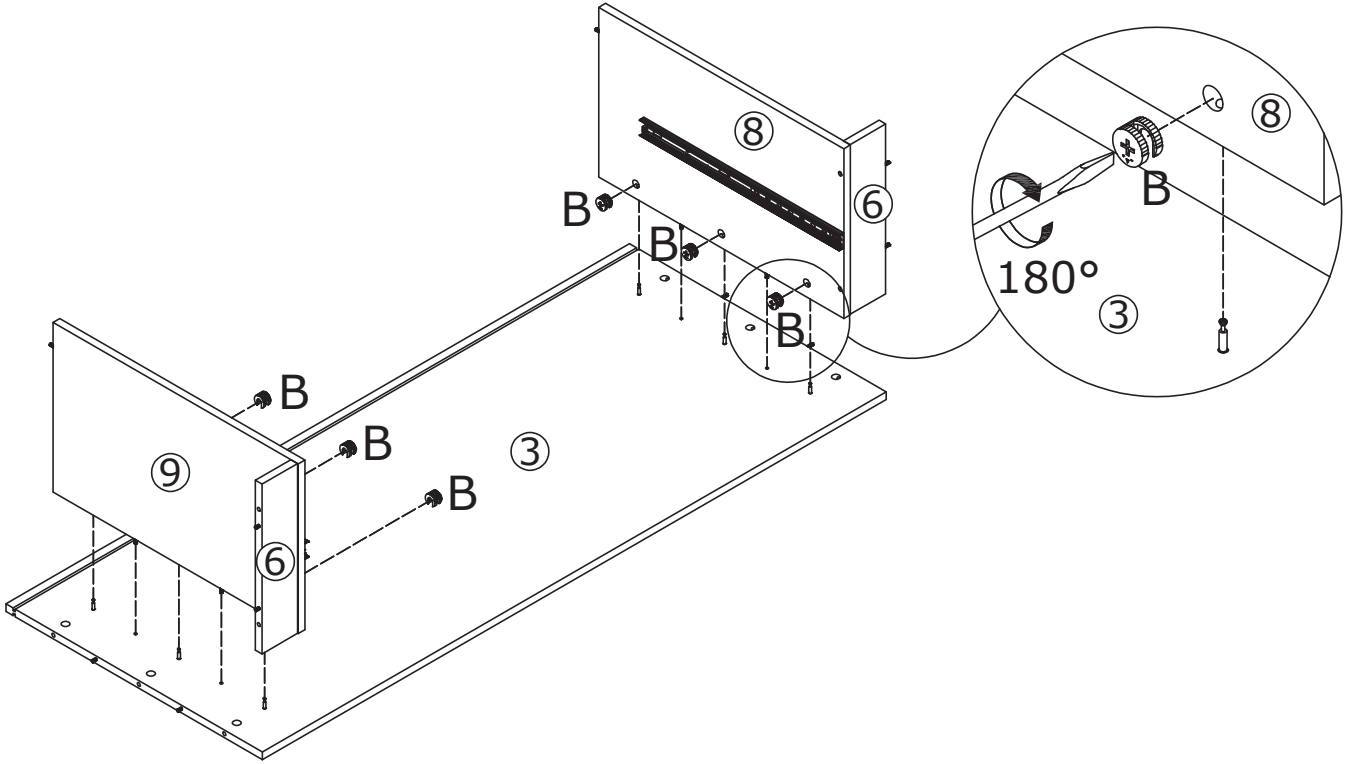
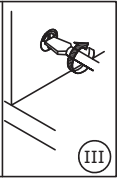
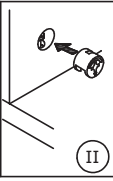
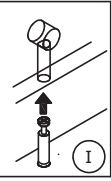

Attach the two components to plate 3, put cam lock(B) into holes in plate 8,9 and turn clockwise to tighten as shown.





7

C x 2

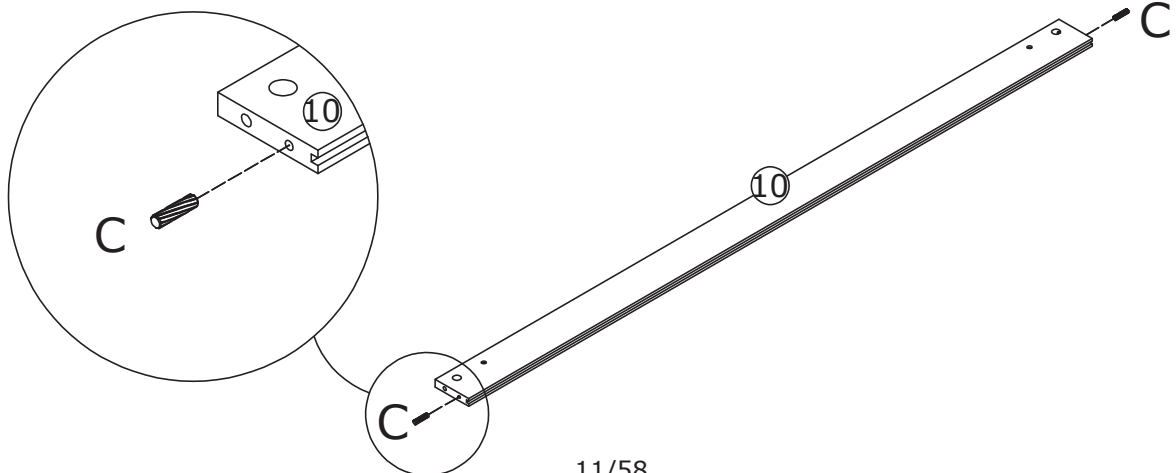
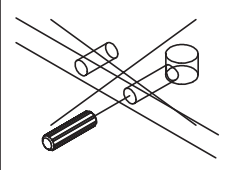
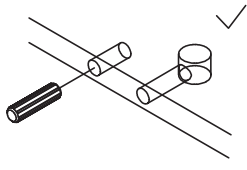

Ø 6 x 30 mm

Insert wooden dowel(C) into plate 10 at first.



8



Attach plate 10 to plate 8 and 9, and fix with screw(D) as shown.

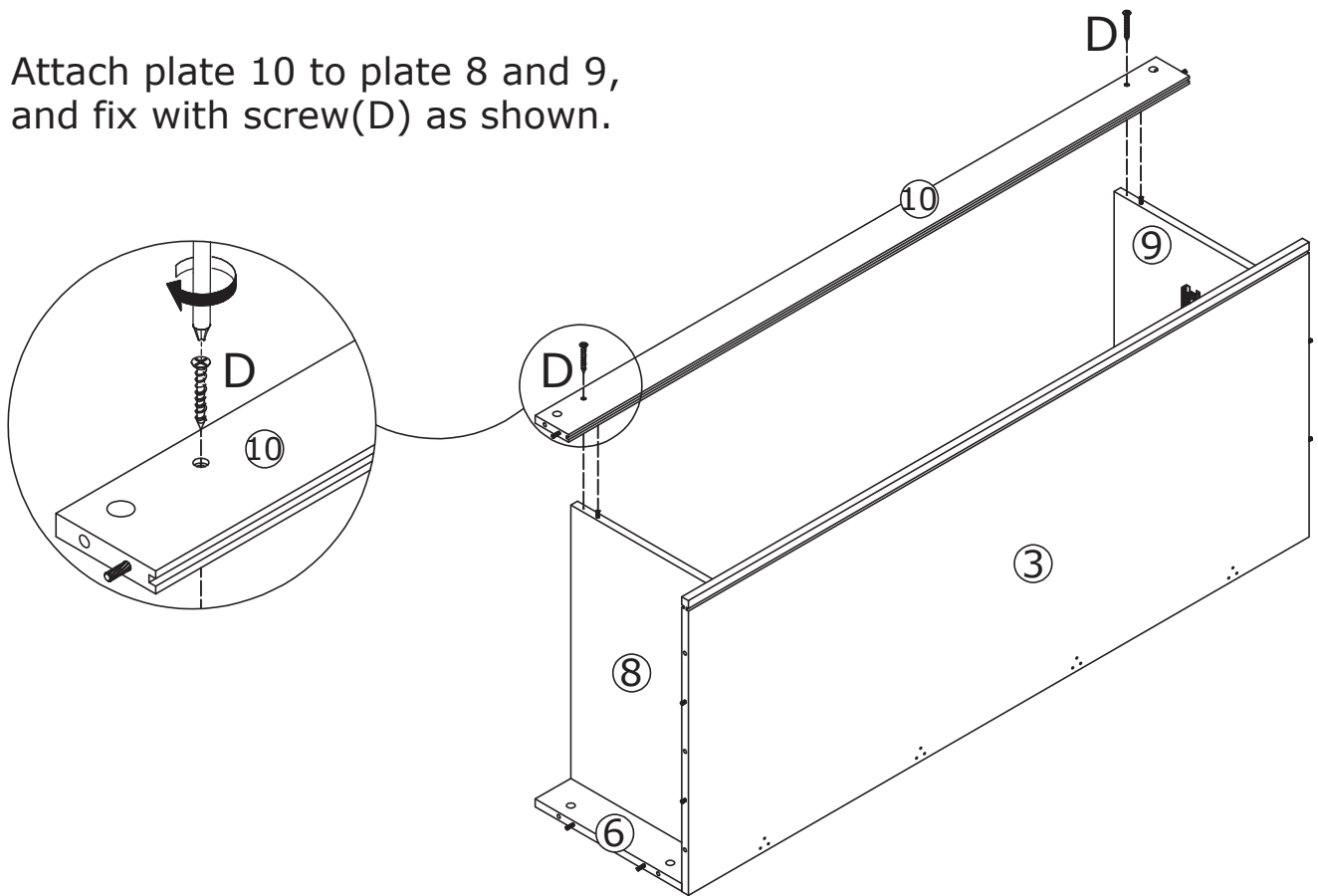

9



Insert quickfit screw(A) into corresponding holes in plate 4 with a screwdriver as shown.

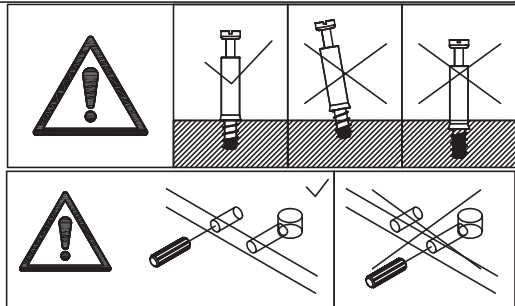

Insert wooden dowel(C) into plate 4 at first.

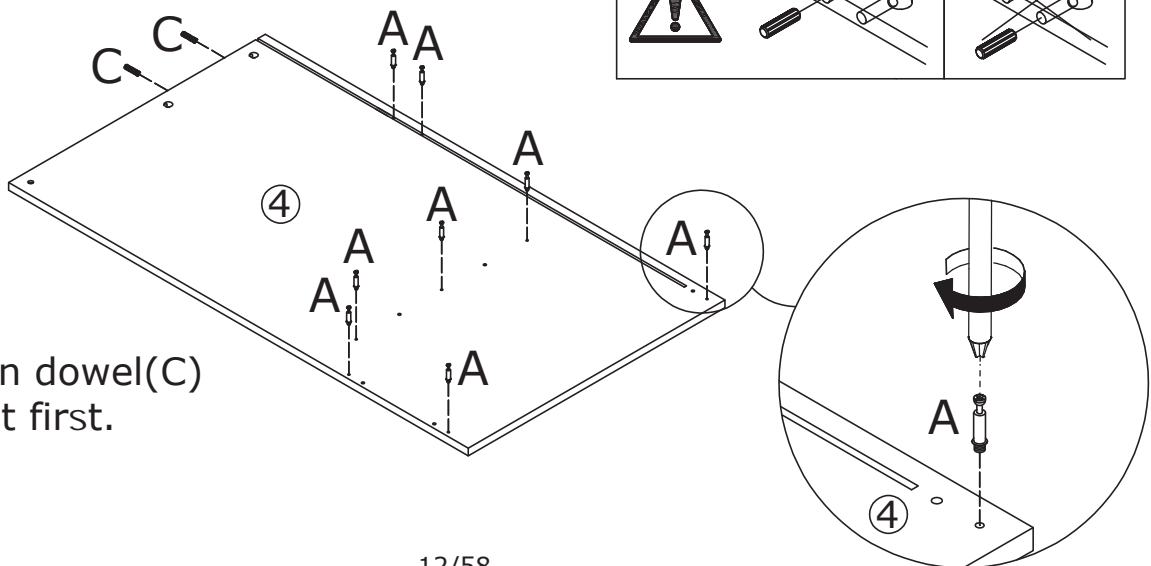

10

B x 8



Ø 15 x 10 mm

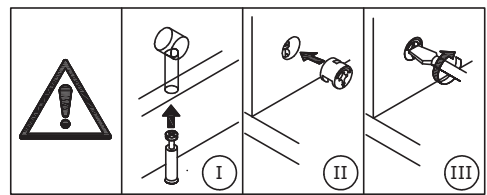

Attach the component and plate 10 and 11 to plate 4, put cam lock(B) into holes in plate 6,3,10,11 and turn clockwise to tighten as shown.

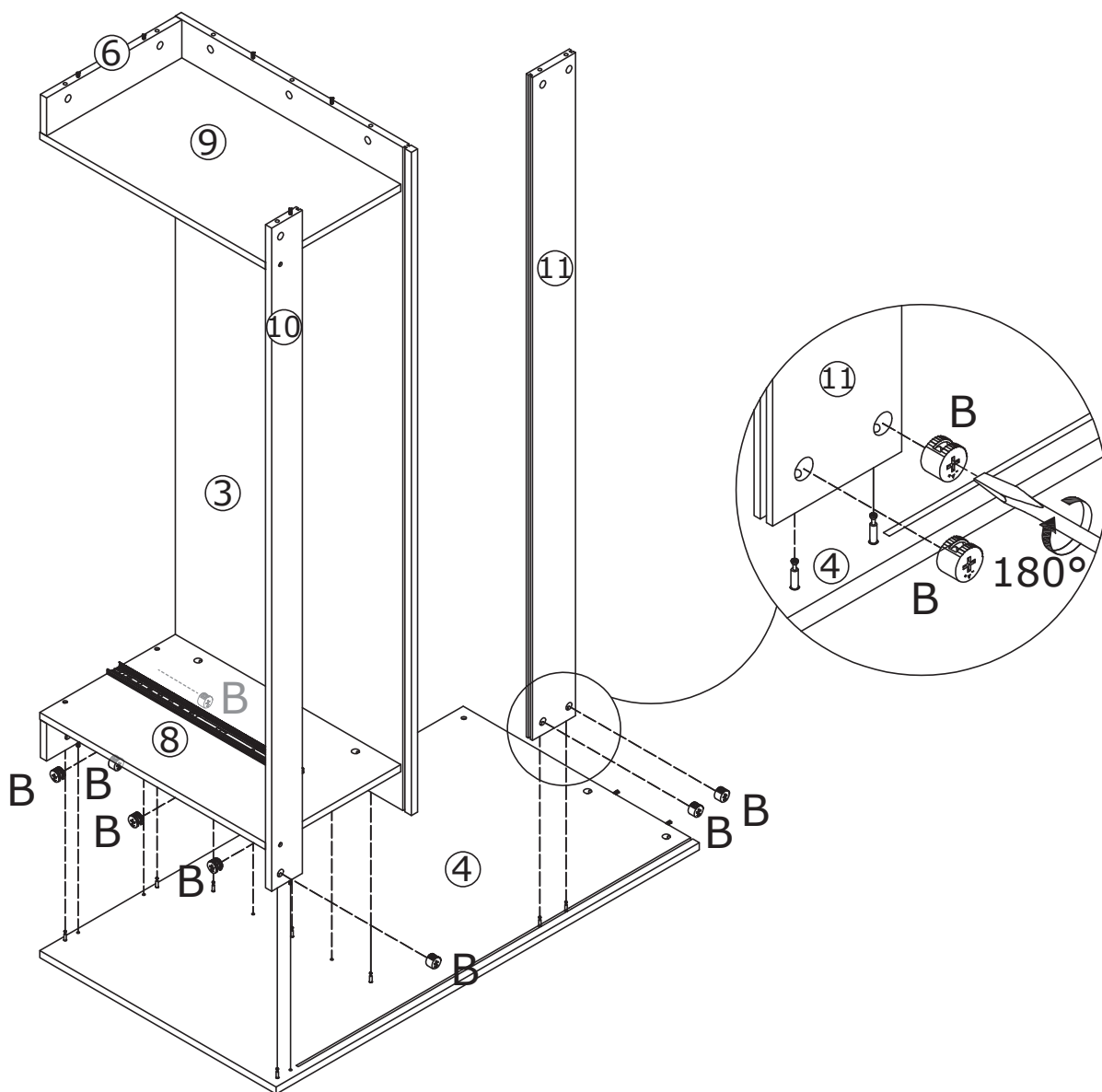

11

Slide plate 12 and 13 along available slots as shown.

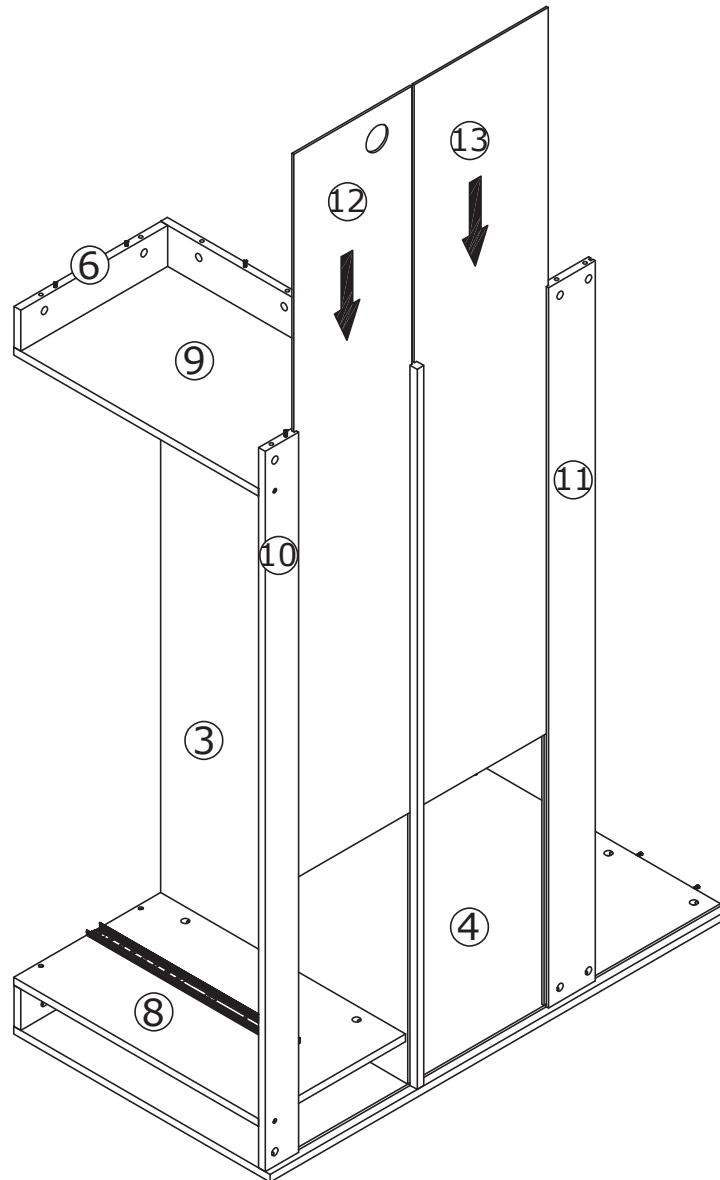

12

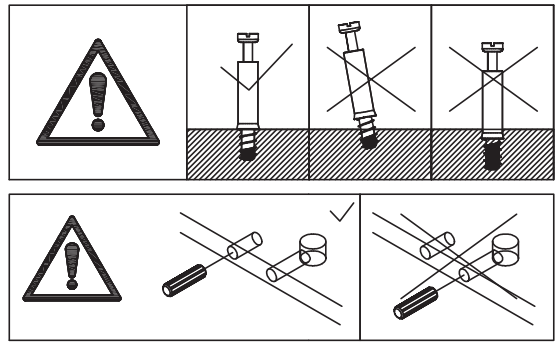

Insert wooden dowel(C) into plate 5 at first.

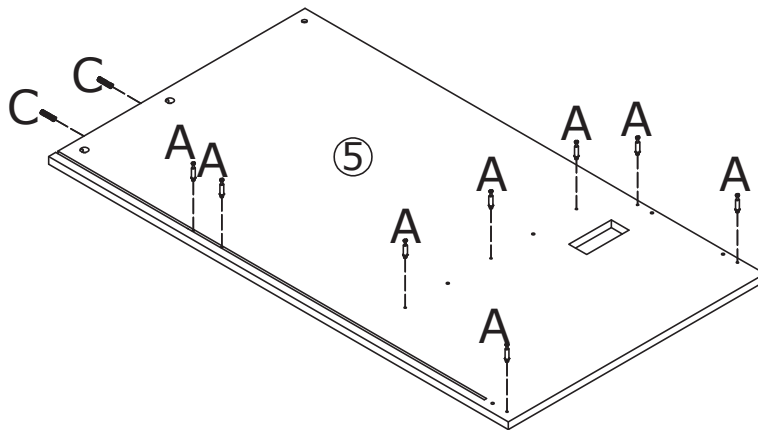

Insert quickfit screw(A) into corresponding holes in plate 5 and 1 with a screwdriver as shown.

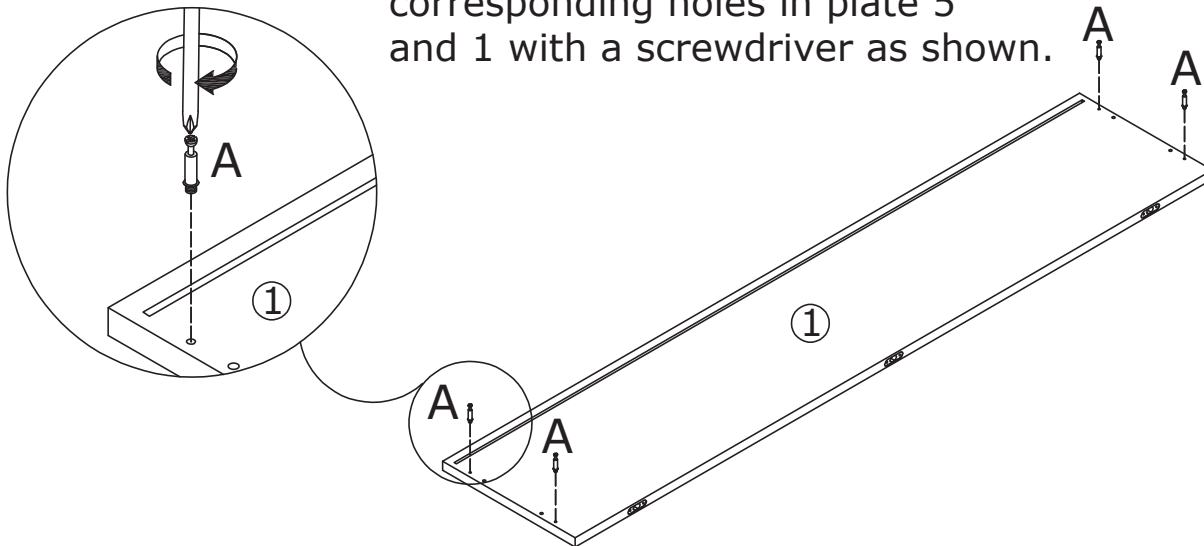

13

B x 8



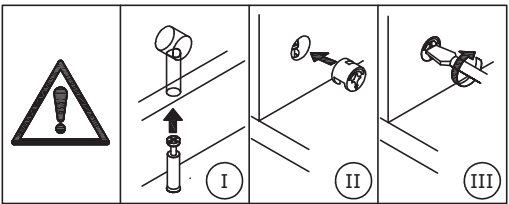

Ø 15 x 10 mm

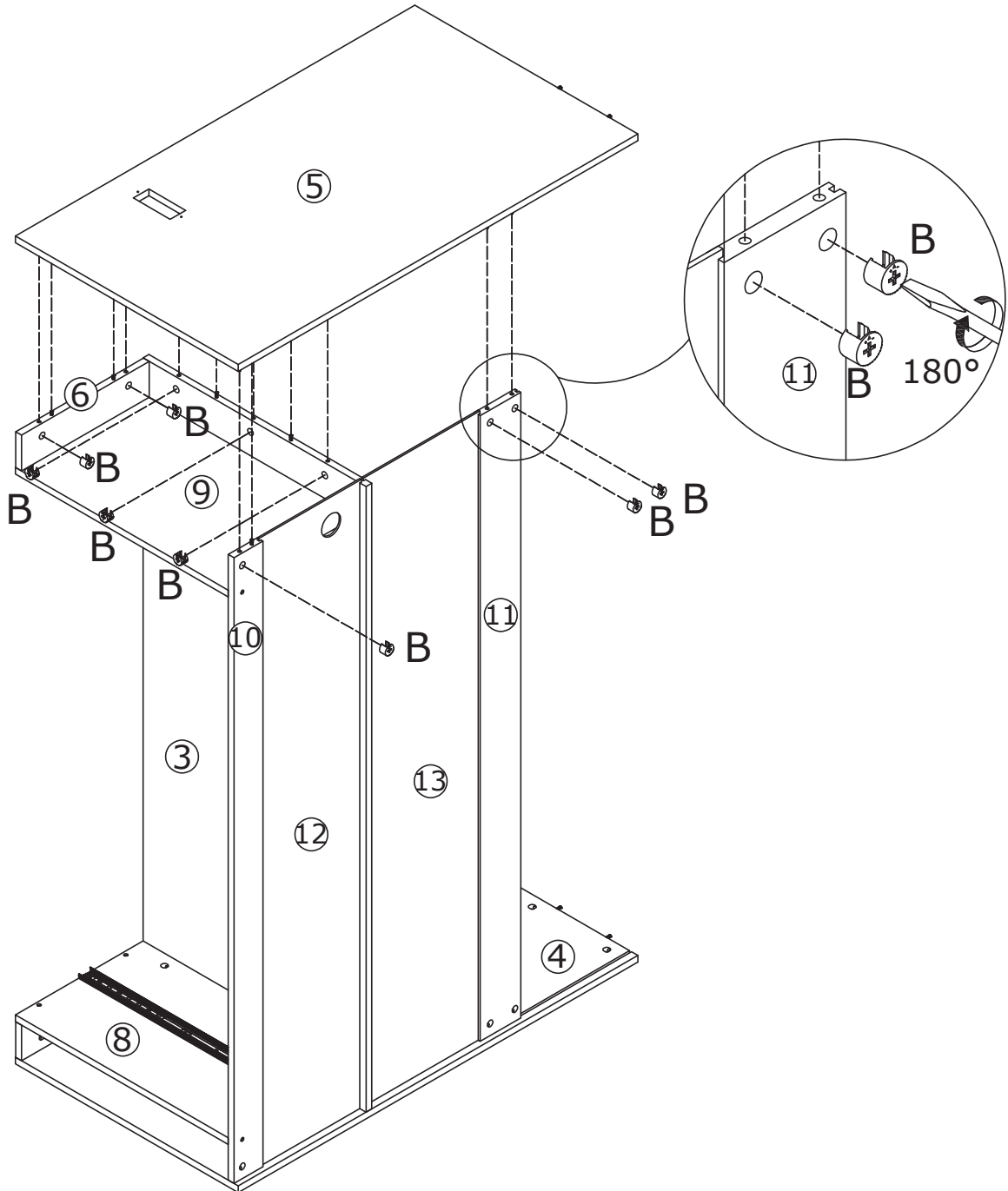

Cover plate 5 to the component and plate 10 and 11, put cam lock(B) into holes in plate 6,3,10,11 and turn clockwise to tighten as shown.

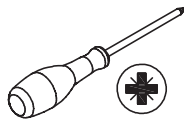

14

F x 1 	G x 2  Ø 3.5 x 12 mm	
--	---	---

Fix part(F) to plate 5 with screw(G) as shown.

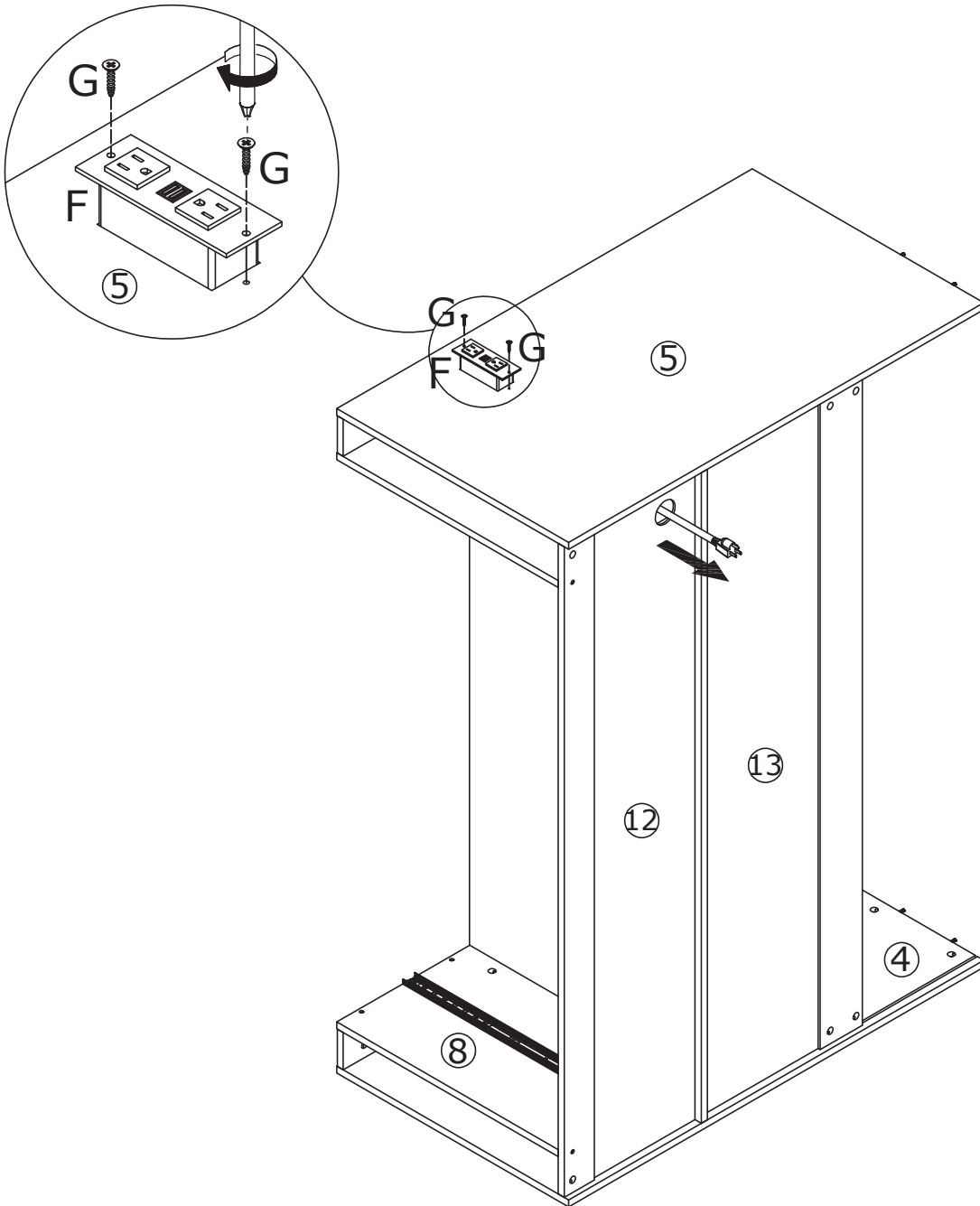

15



Slide plate 13 along available slots as shown.

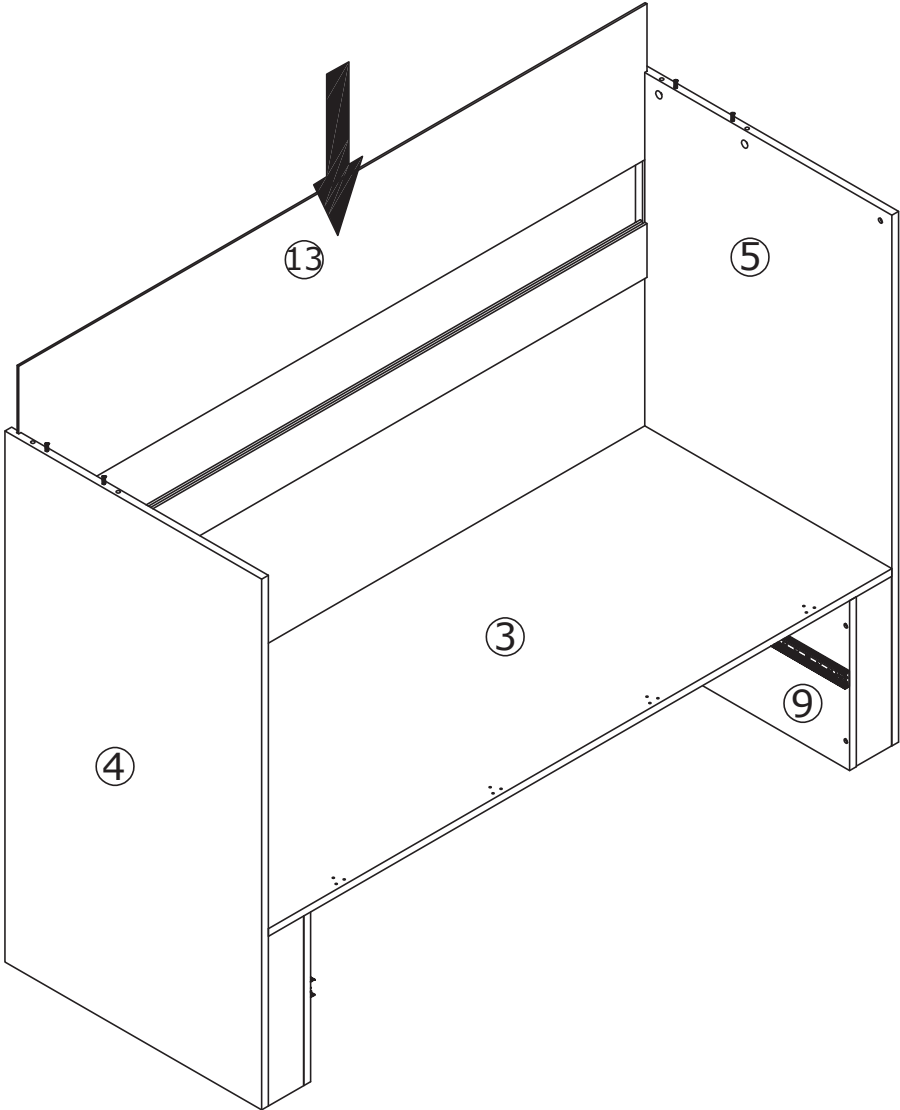

16

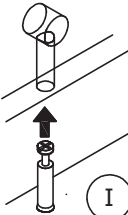
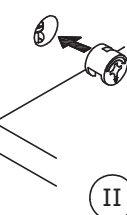
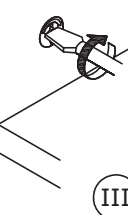

<p>B x 4</p>  <p>Ø 15 x 10 mm</p>	<p>W x 4</p>  <p>18mm</p>	
--	--	---

Cover plate 1 to plate 4 and 5, put cam lock(B) into holes in plate 4,5 and turn clockwise to tighten as shown.

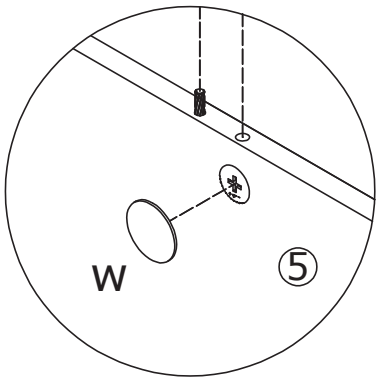
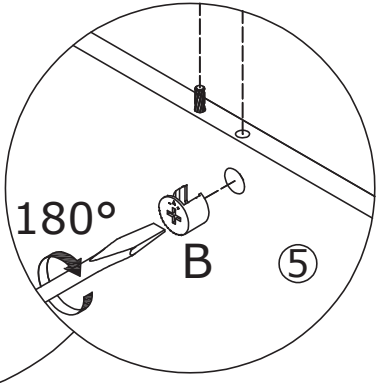
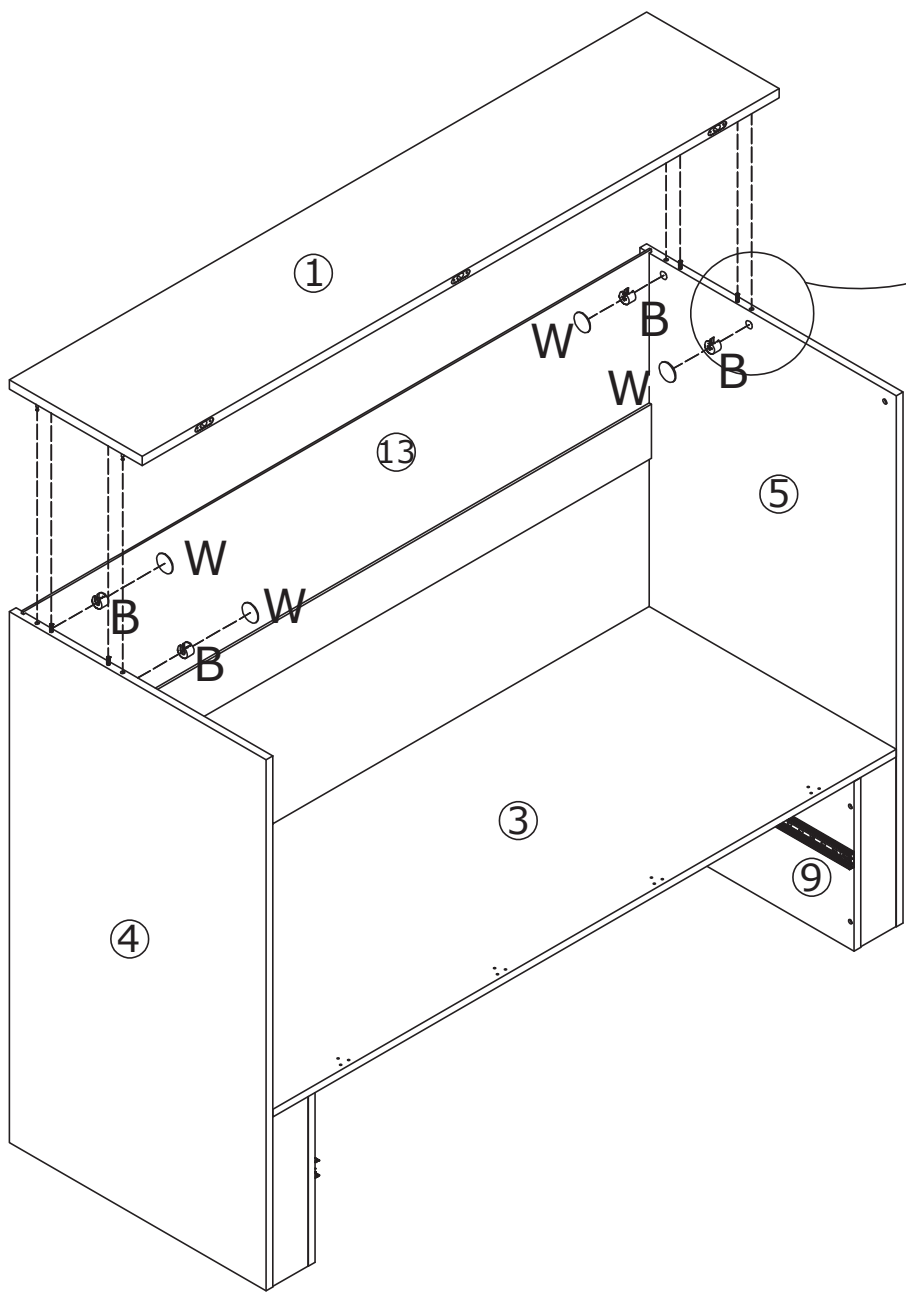

17

<p>H x 3</p> 	<p>E x 12</p>  <p>Ø 3.5 x 12 mm</p>	
--	--	---

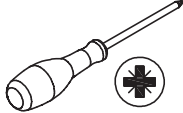
Use hinge(H) to fix plate 2 and plate 1 together with screw(E) as shown.

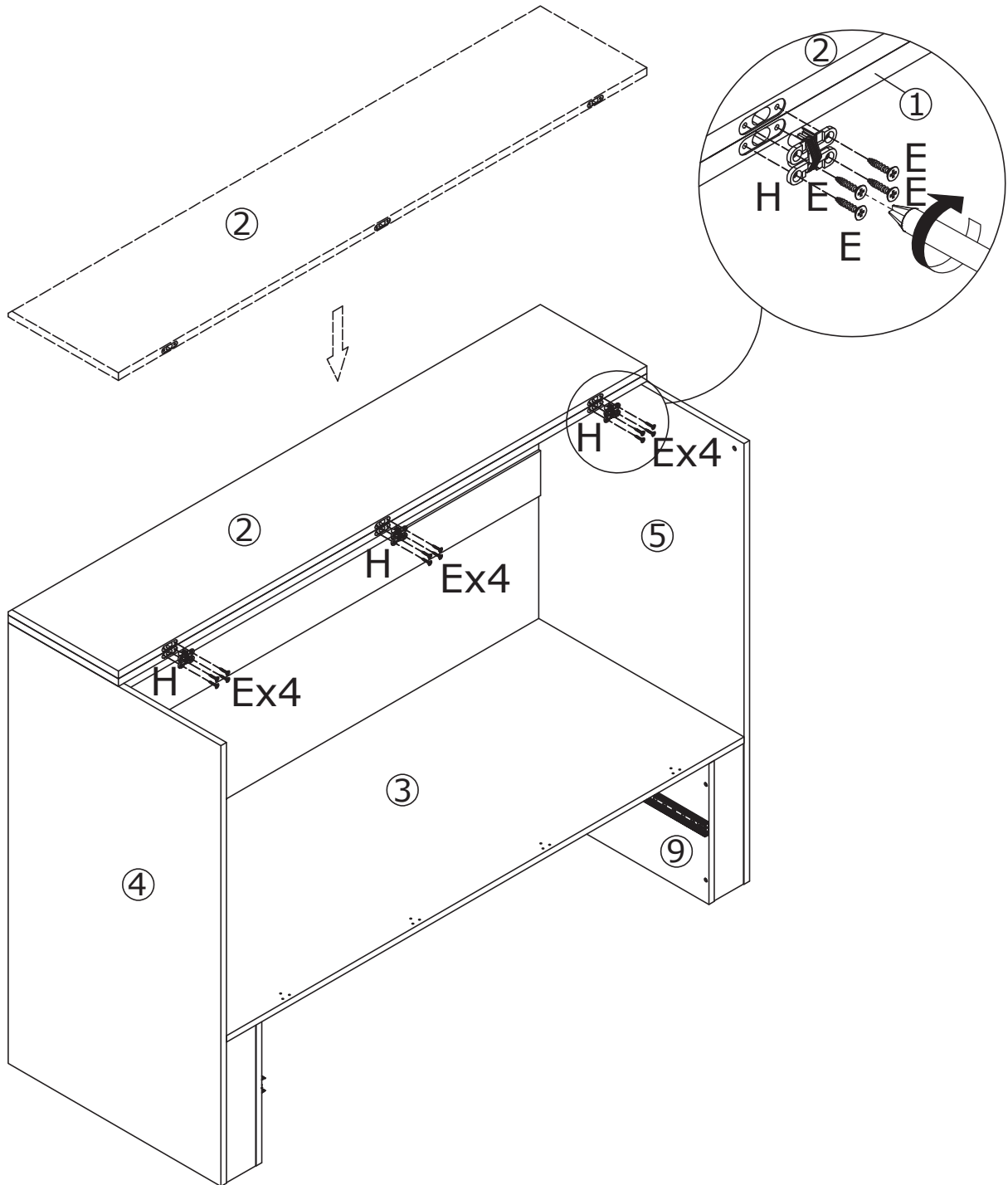

18

<p>C x 8</p>  <p>∅ 6 x 30 mm</p>	
---	--

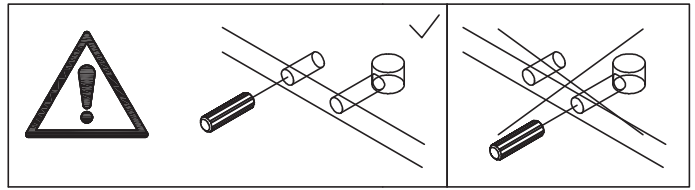

Insert wooden dowel(C) into plate 20 and 23 at first.

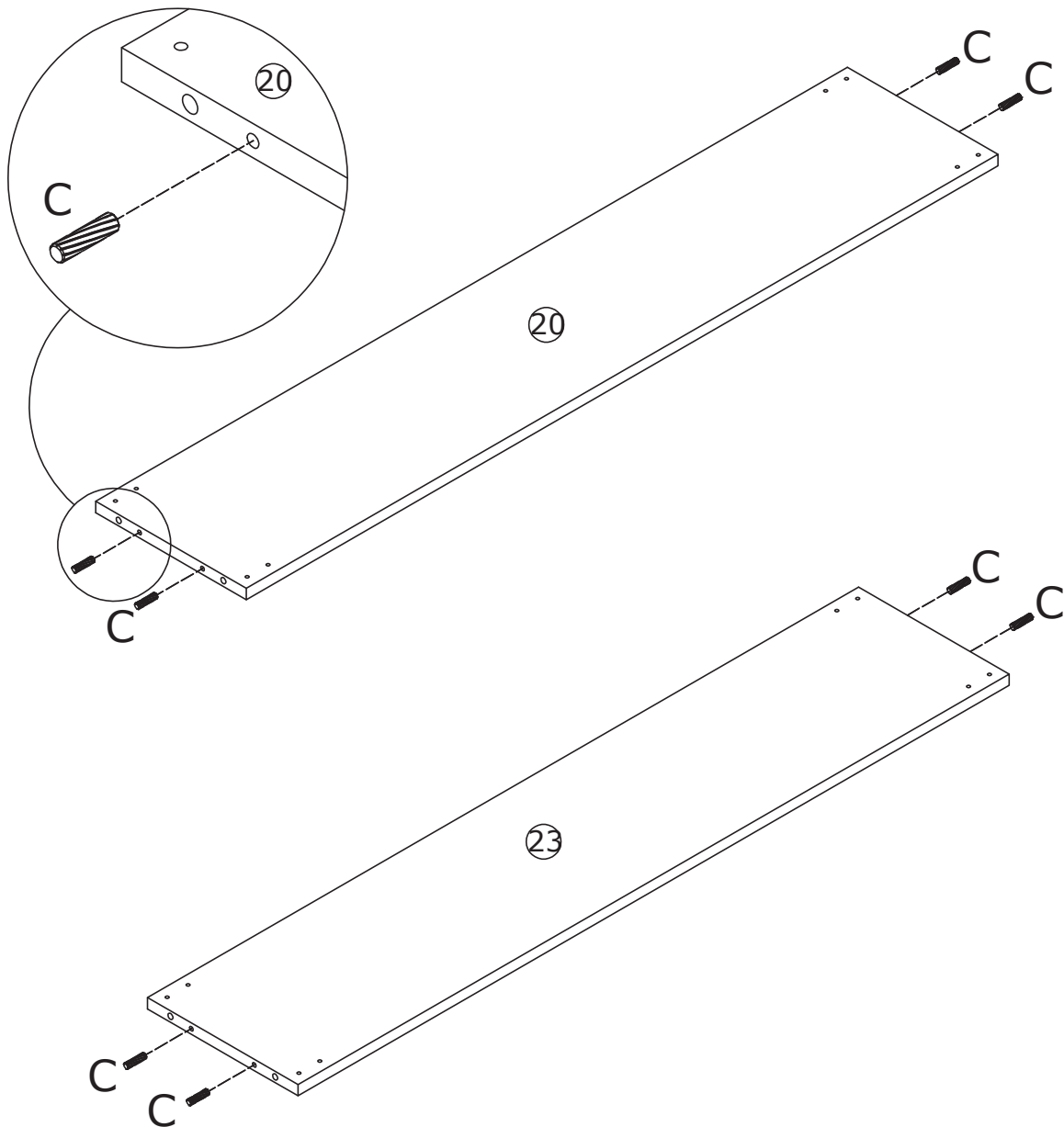

19

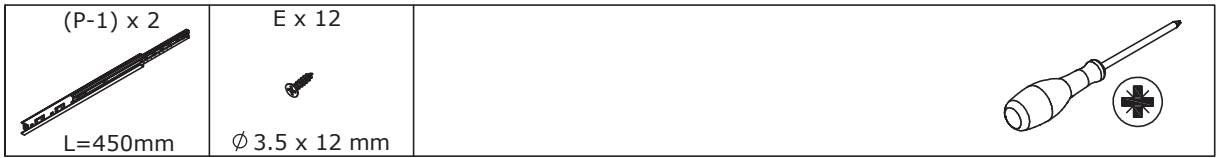

See page 7 for the installation method of slide rail (P-1)

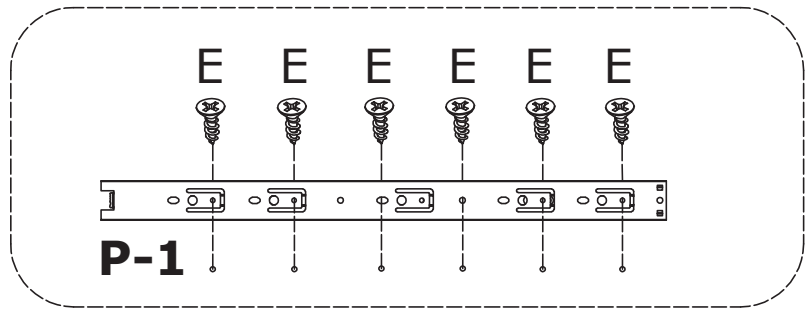

Fix slide rail(P-1) to plate 18 and 19 with screw(E) as shown.

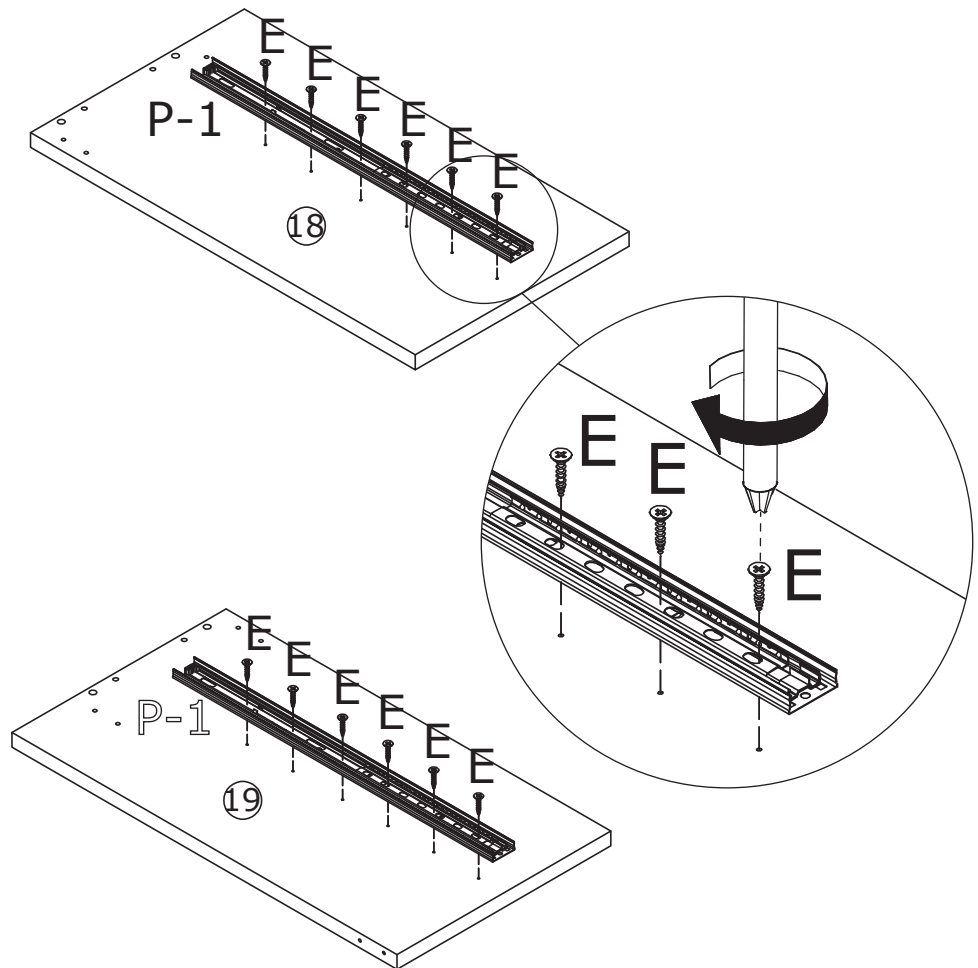

20

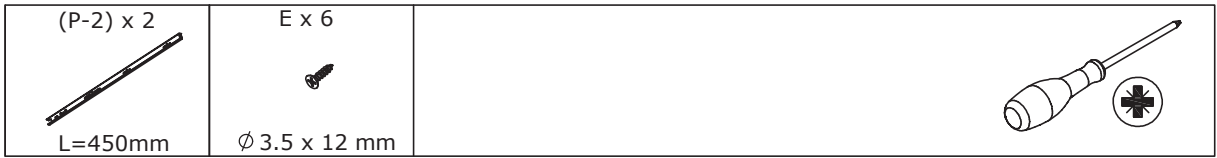

Fix runner(P-2) to plate 18 and 19 with screw(E) as shown.

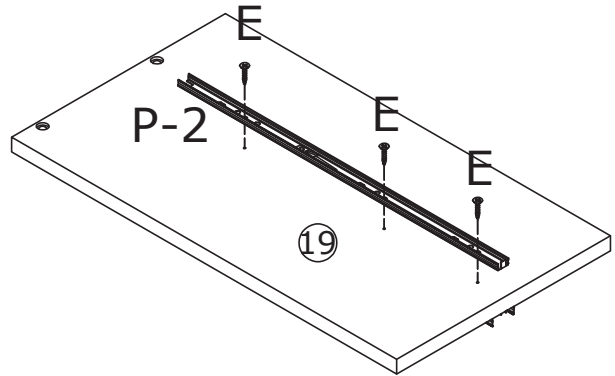
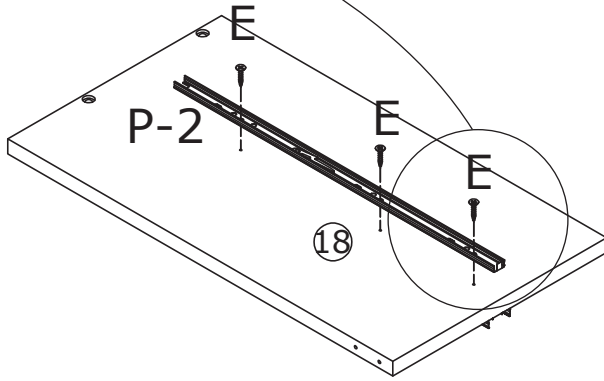
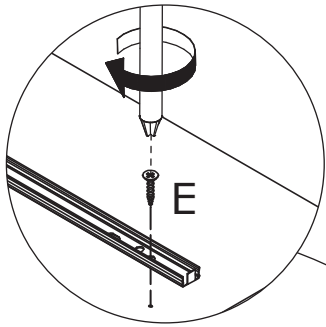
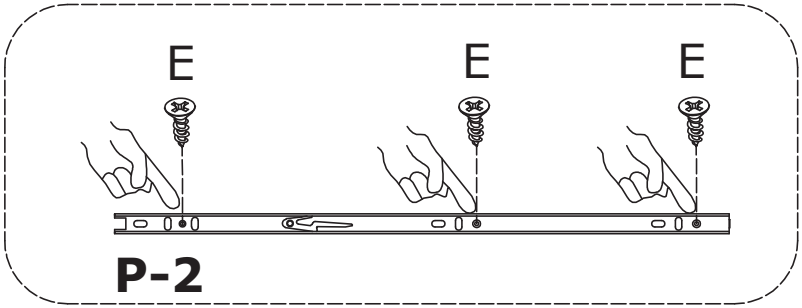

21

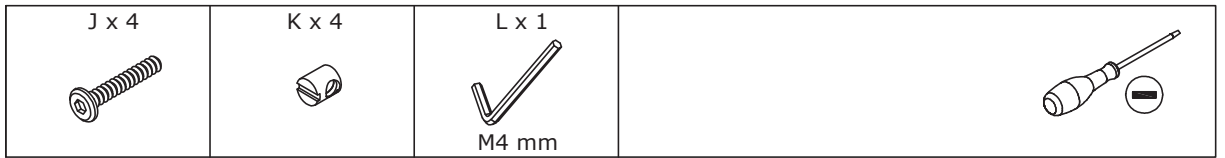

Fix plate 18 and 19 to plate 20 with screw(J) as shown.

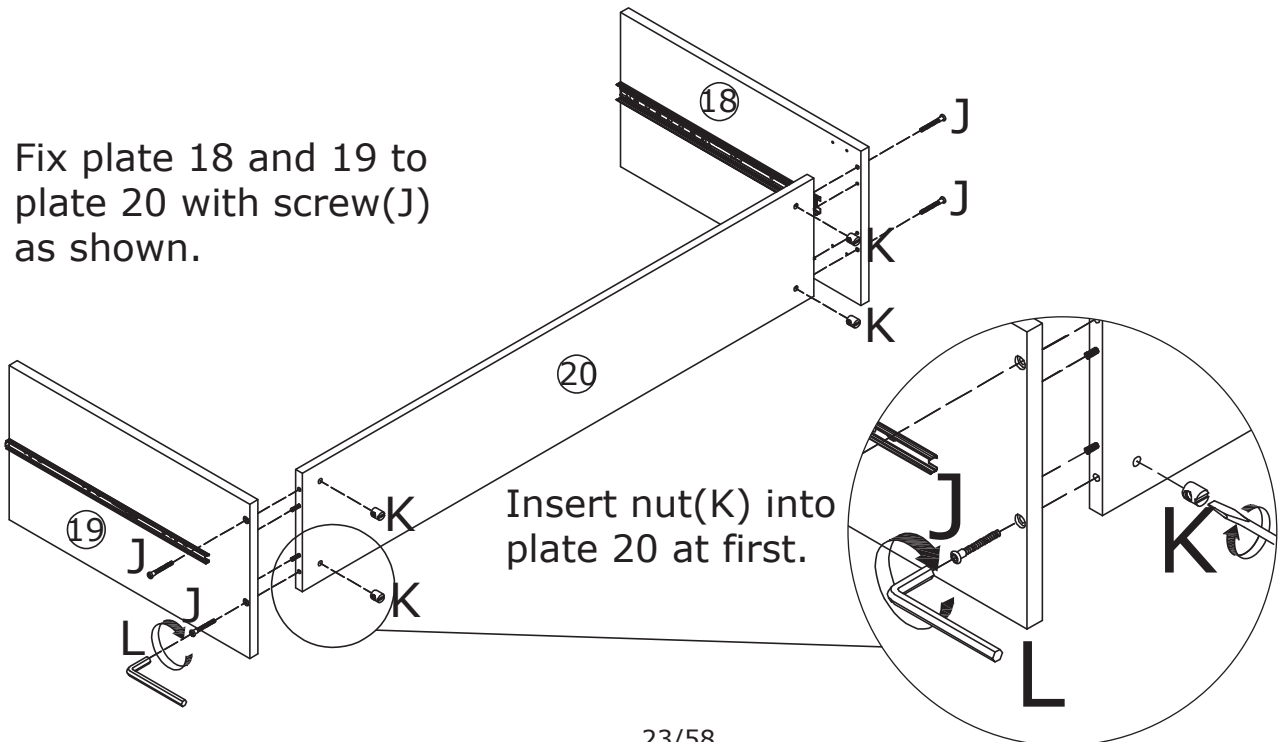

22

M x 4 	E x 16  Ø 3.5 x 12 mm	
--	--	---

Fix part(M) to plate 18, 20 and 19 with screw(E) as shown.

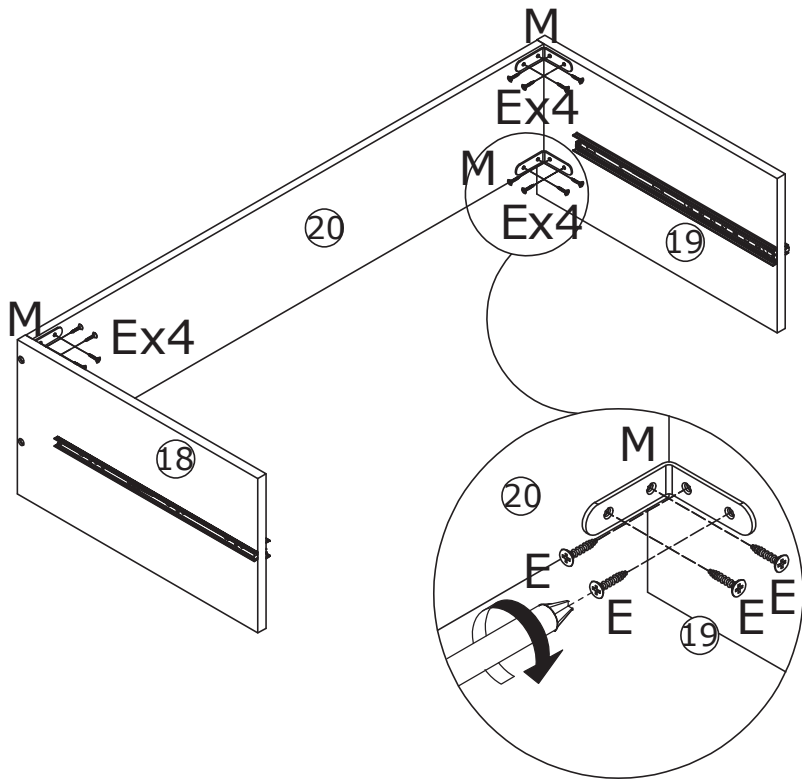

23

N x 2 	V x 4  Ø 4 x 20 mm	
--	---	---

Fix wheel(N) to plate 18 and 19 with screw(V) as shown.

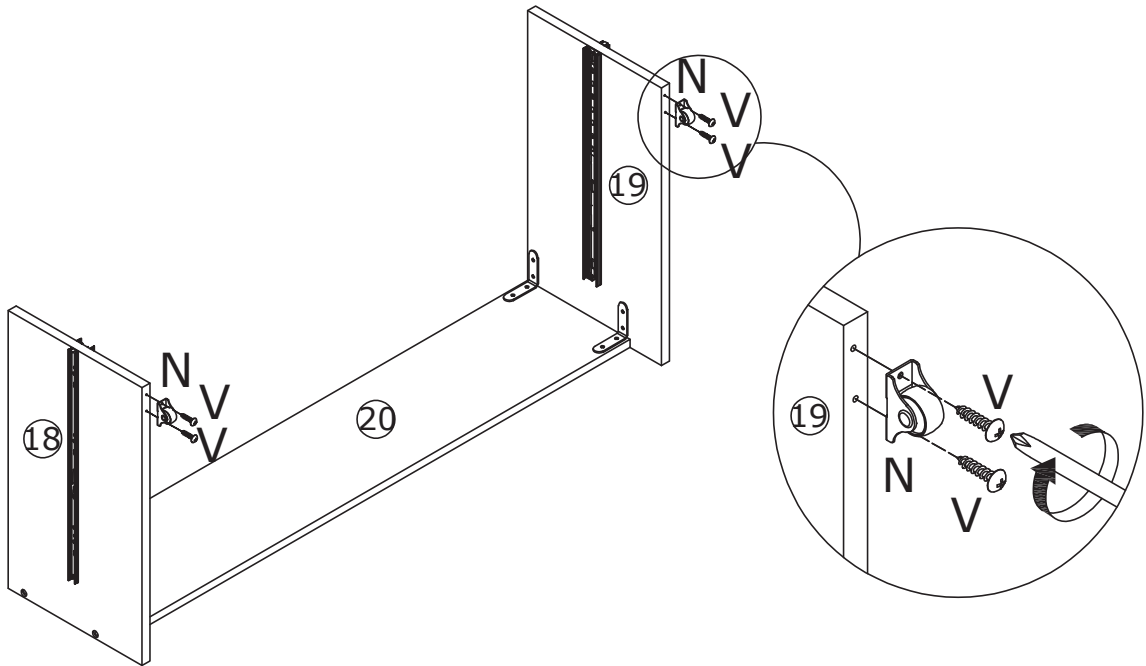

24

<p>(P-1) x 2</p>  <p>L=450mm</p>	<p>E x 12</p>  <p>∅ 3.5 x 12 mm</p>	
---	--	---

See page 7 for the installation method of slide rail (P-1)

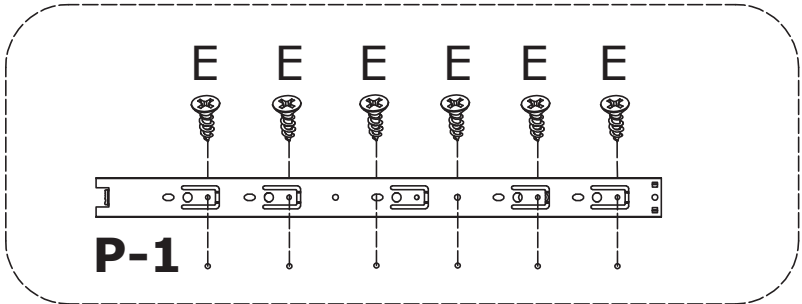

Fix slide rail(P-1) to plate 21 and 22 with screw(E) as shown.

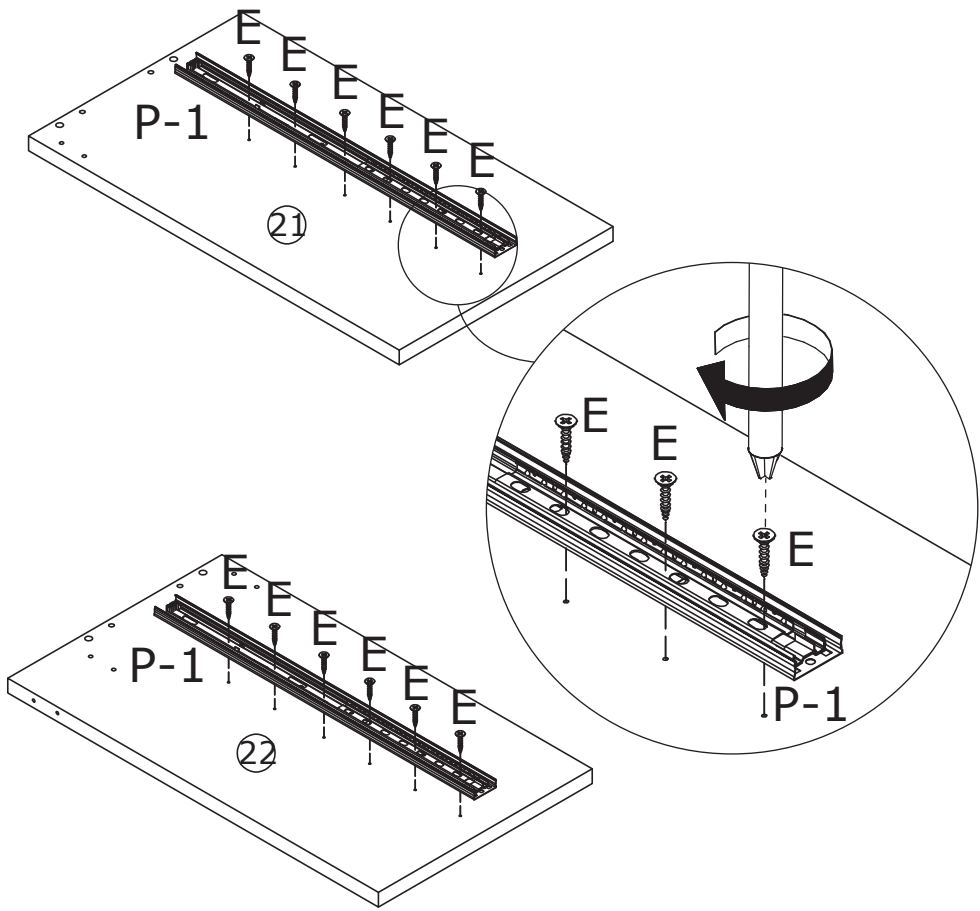

25

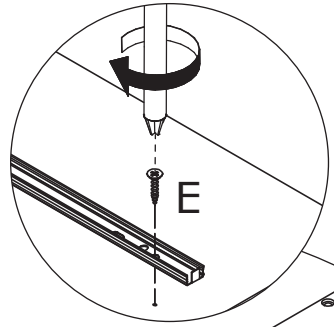
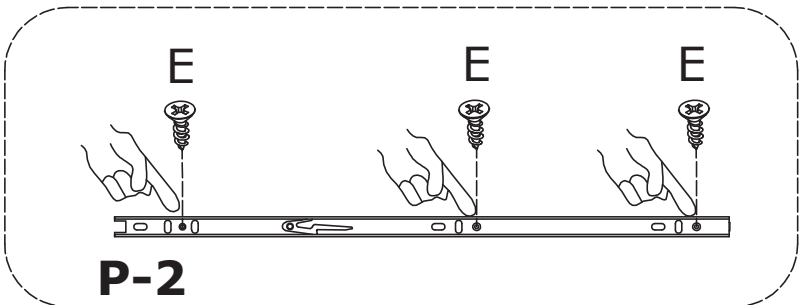

(P-2) x 2  L=450mm	E x 6  Ø 3.5 x 12 mm	
---	---	---

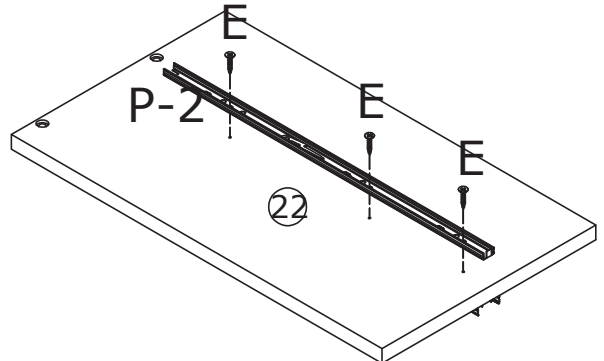
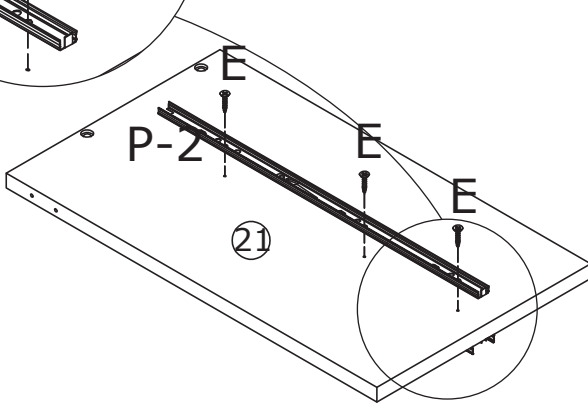

Fix runner(P-2) to plate 21 and 22 with screw(E) as shown.

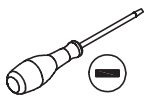

26

J x 4 	K x 4 	L x 1  M4 mm	
--	--	---	---

Insert nut(K) into plate 23 at first.
Fix plate 21 and 22 to plate 23 with screw(J) as shown.

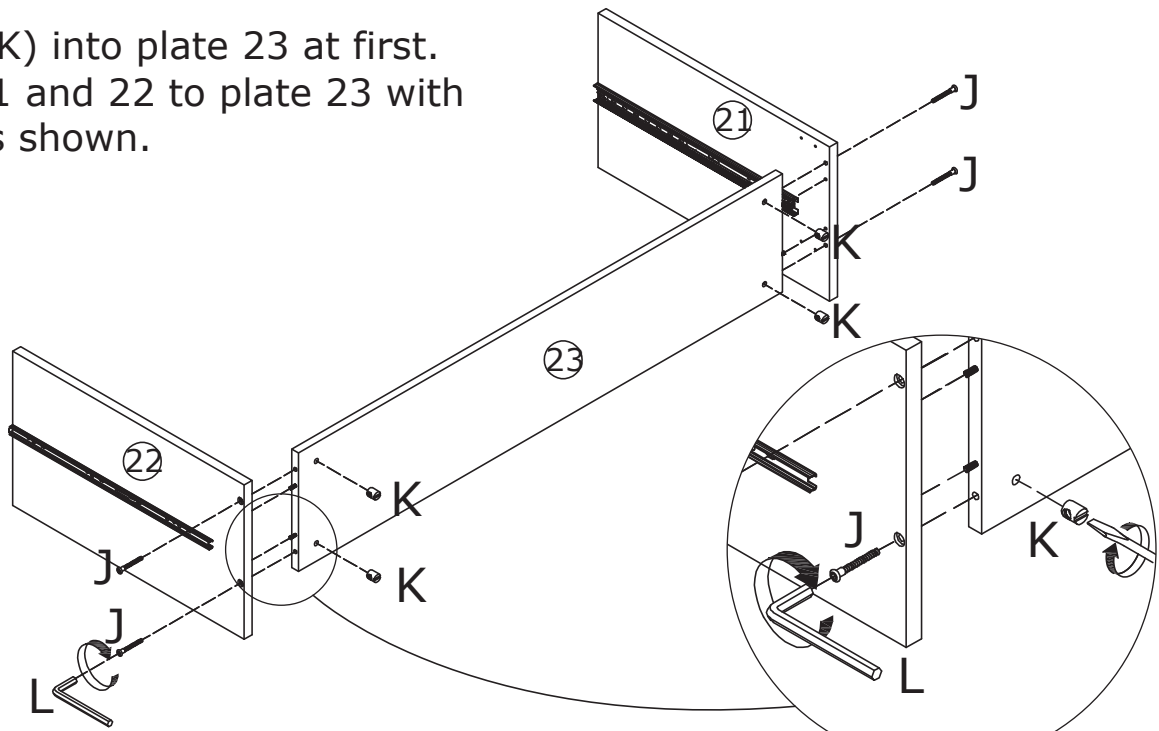

27

M x 4 	E x 16  Ø 3.5 x 12 mm	
--	--	---

Fix part(M) to plate 21, 23 and 22 with screw(E) as shown.

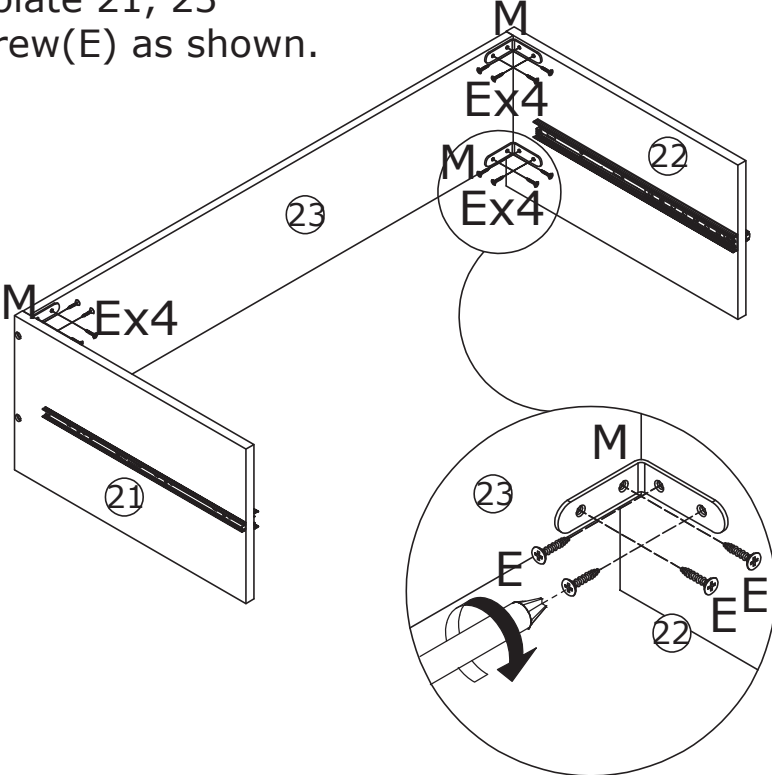

28

N x 2 	V x 4  Ø 4 x 20 mm	
--	---	---

Fix wheel(N) to plate 21 and 22 with screw(V) as shown.

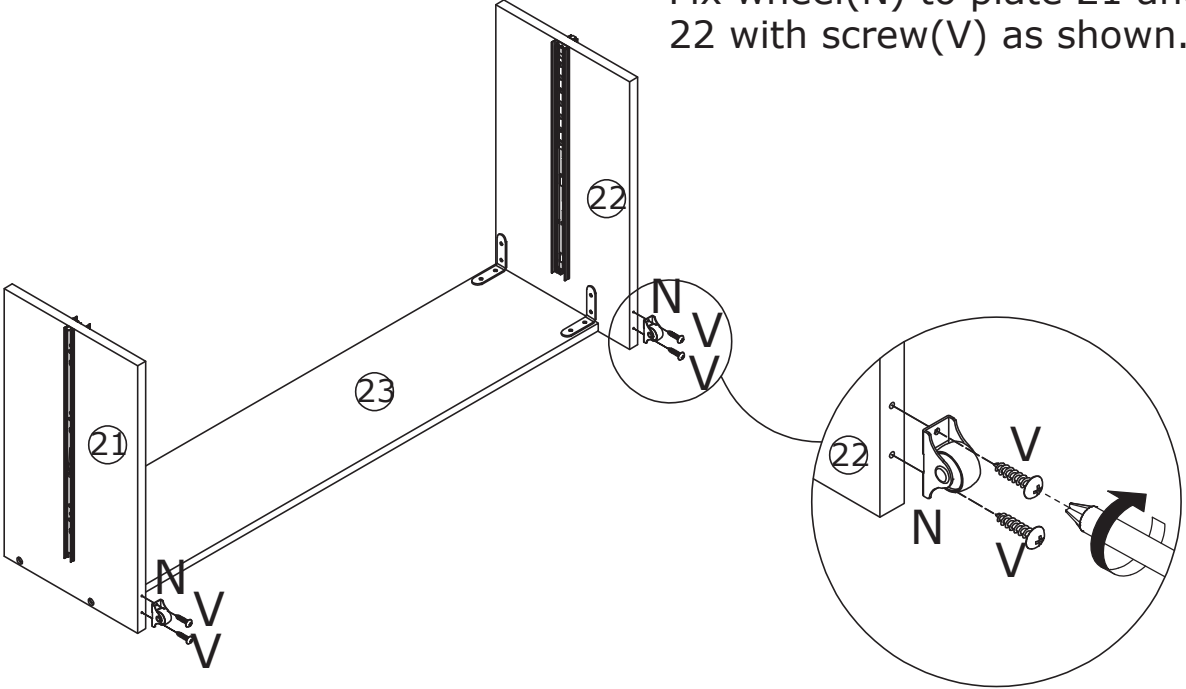

29

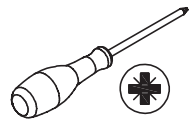
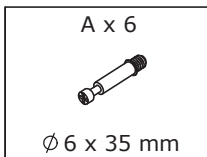

Insert quickfit screw(A) into corresponding holes in plate 29 with a screwdriver as shown.

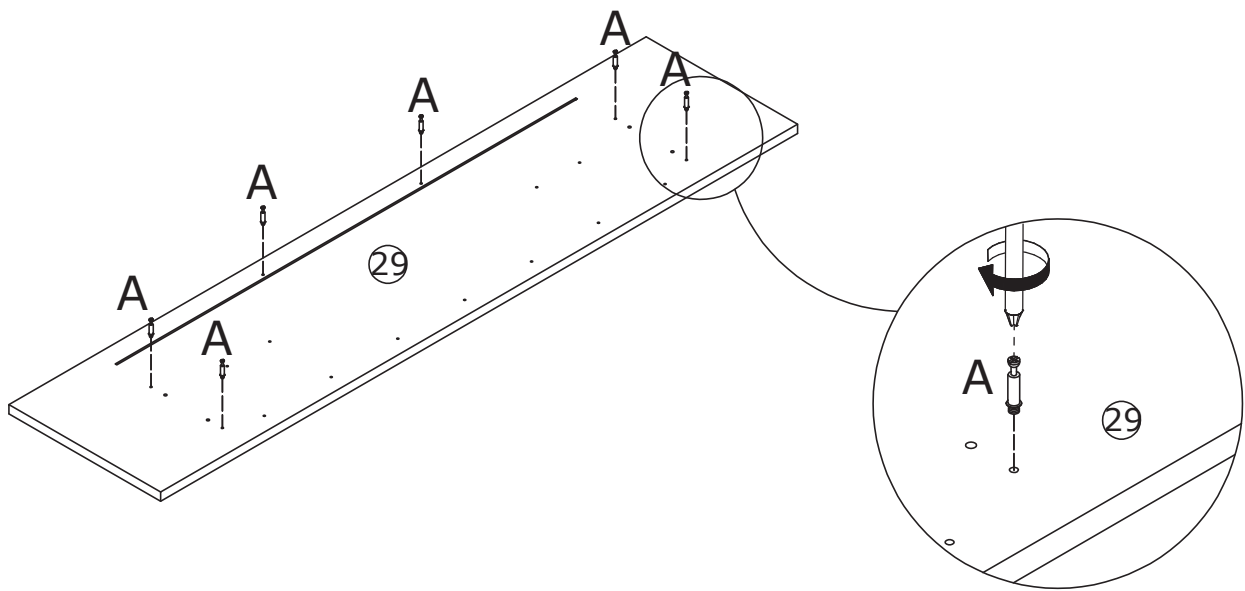
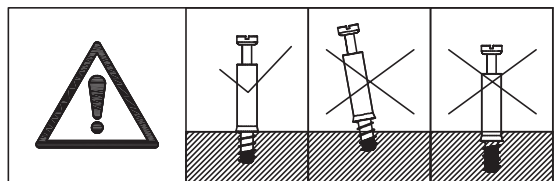

30

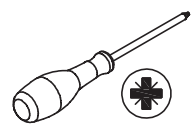
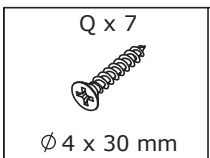

Fix plate 28 to plate 29 with screw(Q) as shown.

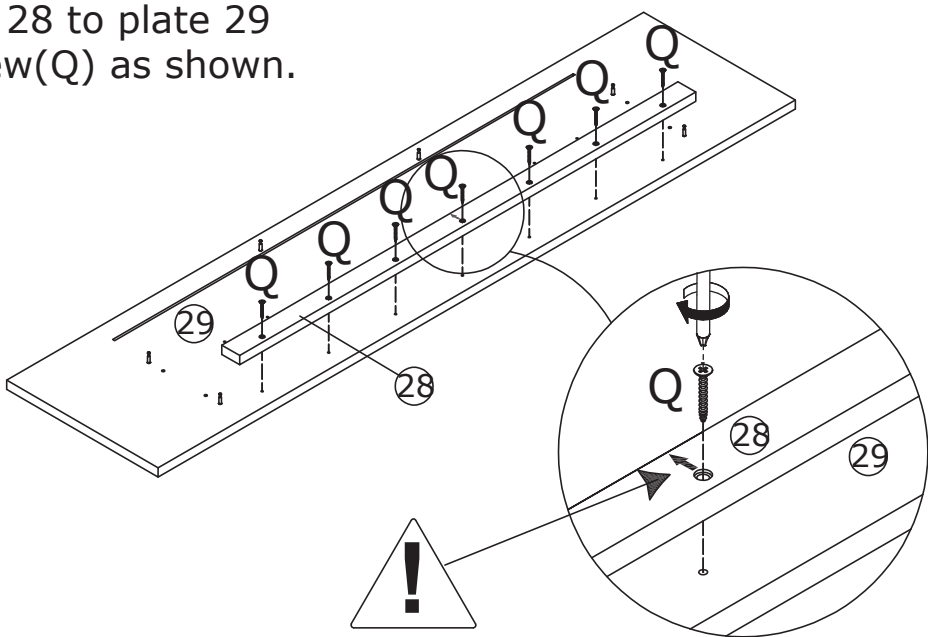

!"#!

31

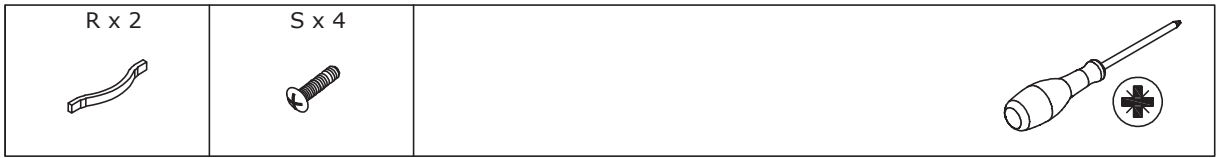

Fix handle(R) to plate 29 with screw(S) as shown.

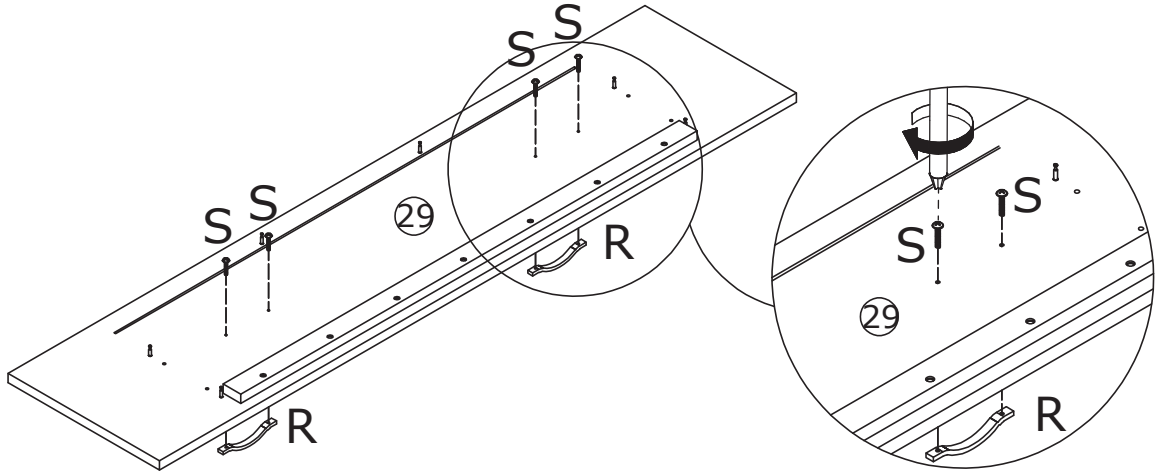

32



Insert wooden dowel(C) into plate 24, 25 and 26 at first.

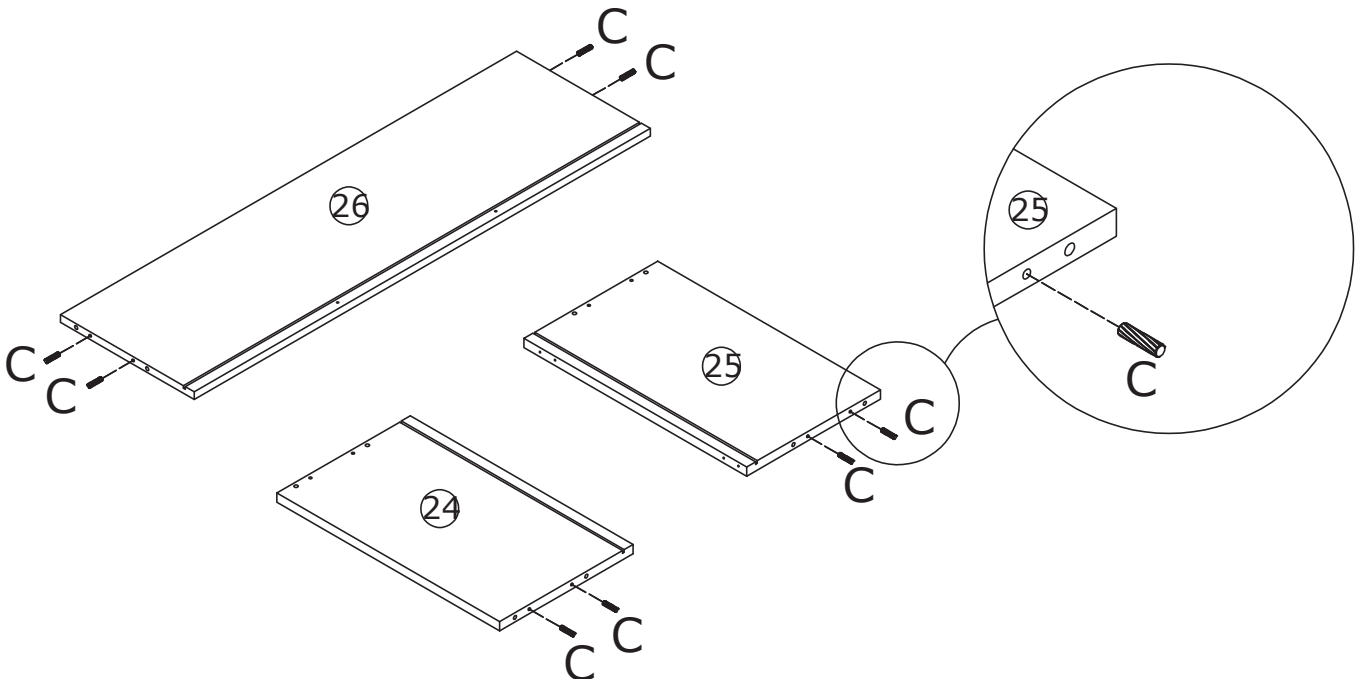
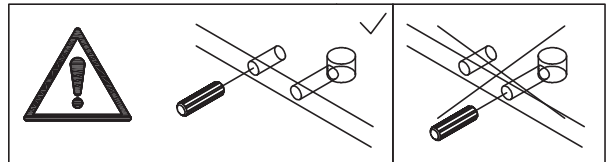

33

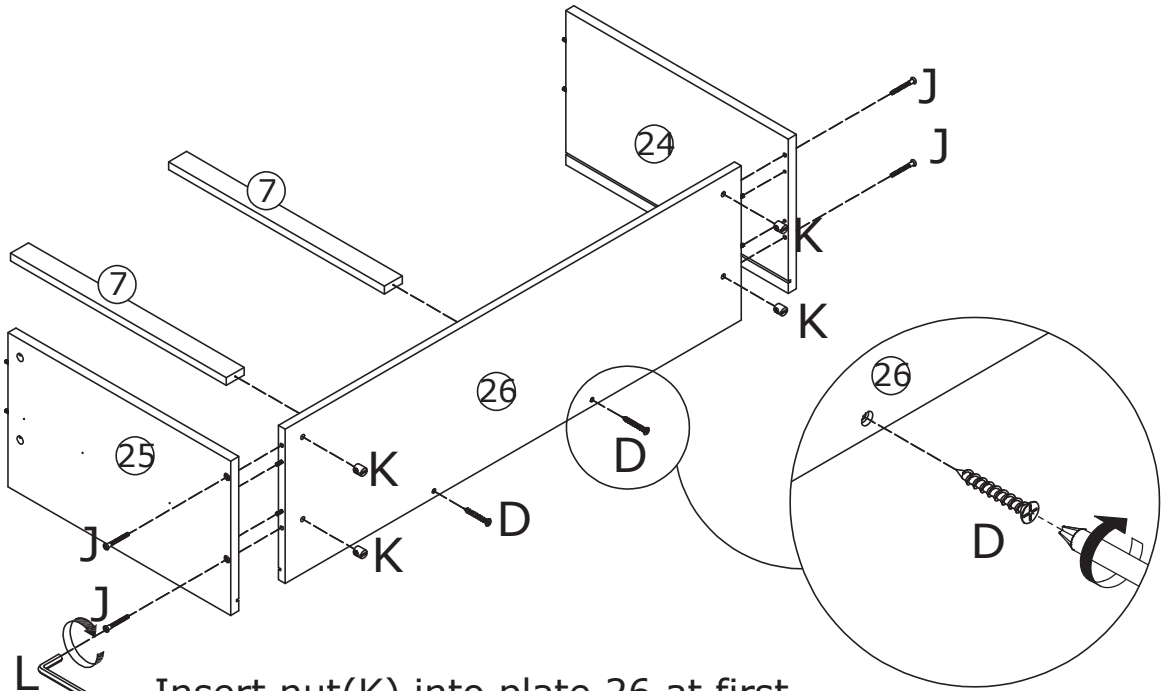
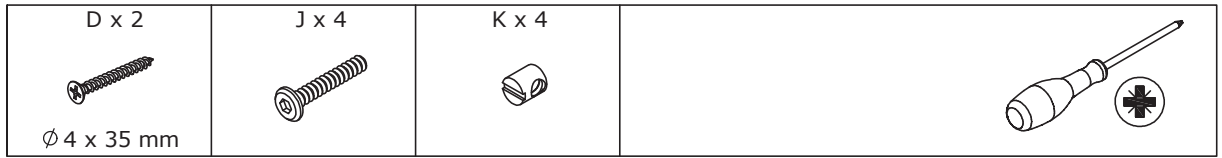

Insert nut(K) into plate 26 at first.
Fix plate 25 and 24 to plate 26 with screw(J) as shown.
Fix plate 7 to plate 26 with screw(D) as shown.

34

Slide plate 27 along grooves as shown.

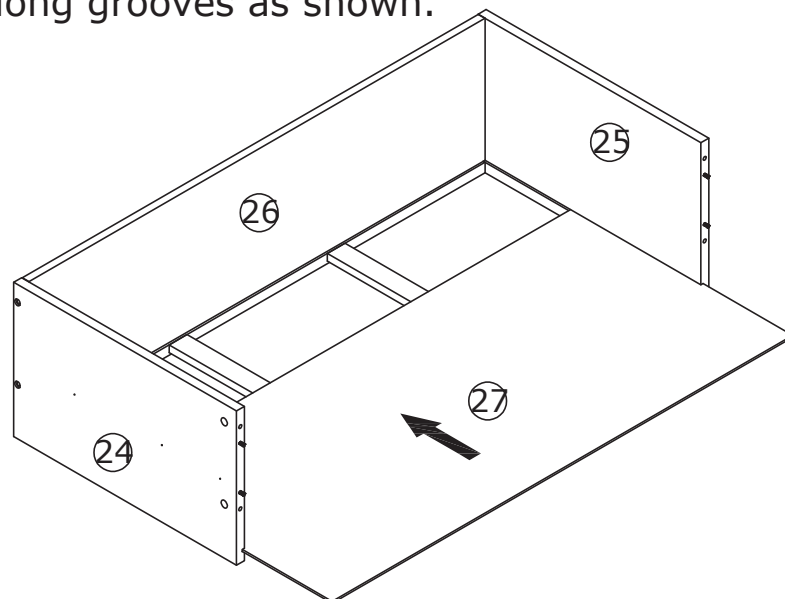

35

$B \times 6$  $\phi 15 \times 10 \text{ mm}$	
---	---

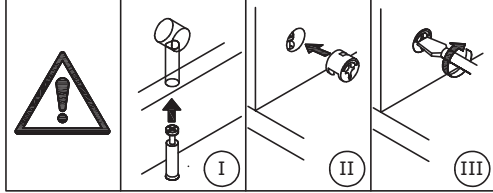
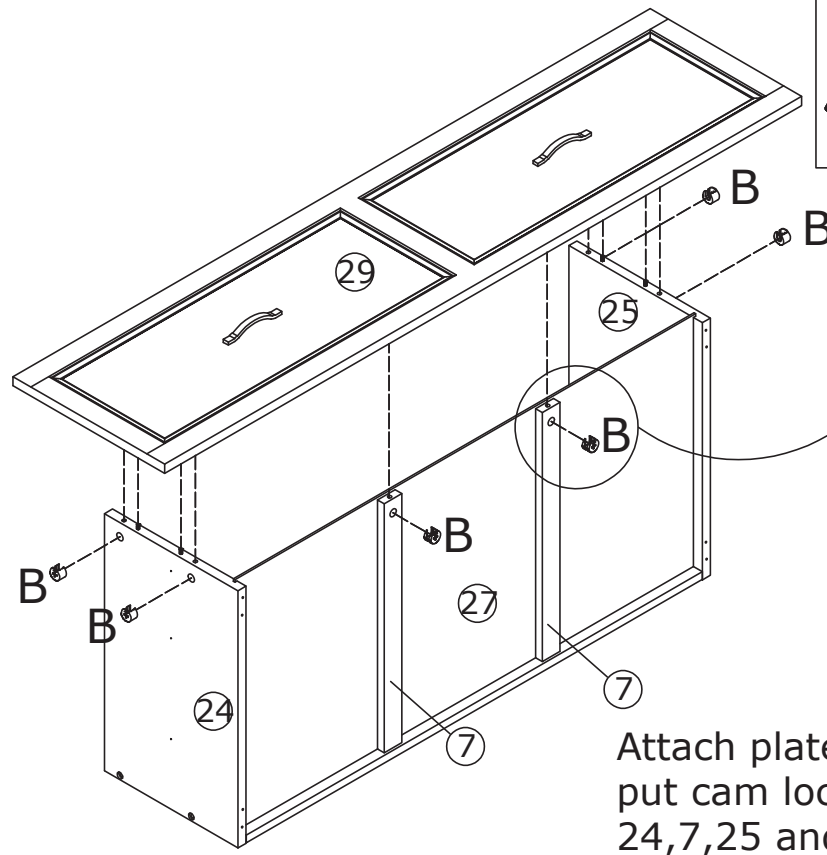

Attach plate 29 to the component, put cam lock(B) into holes in plate 24,7,25 and turn clockwise to tighten as shown.

36

$N \times 4$ 	$V \times 8$  $\phi 4 \times 20 \text{ mm}$	
---	--	---

Fix wheel(N) to plate 24 and 25 with screw(V) as shown.

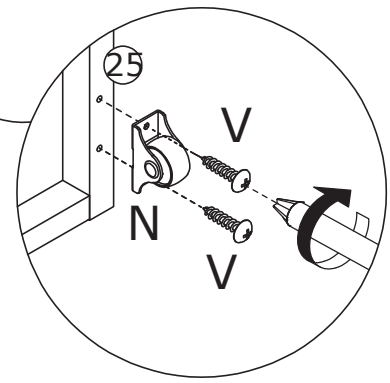
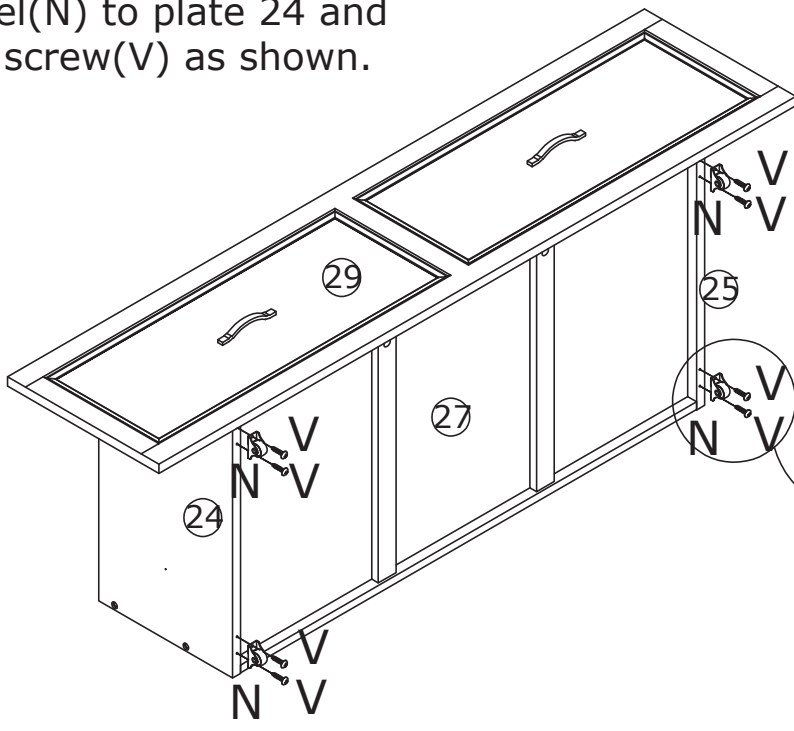

37

(P-2) x 2 L=450mm 	E x 6 Ø 3.5 x 12 mm 	
---	---	---

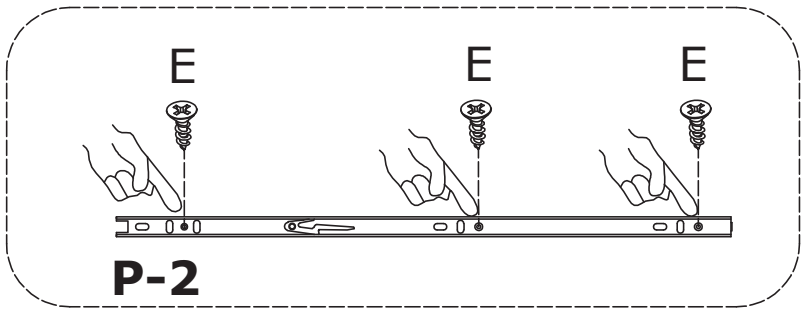

Fix runner(P-2) to plate 24 and 25 with screw(E) as shown.

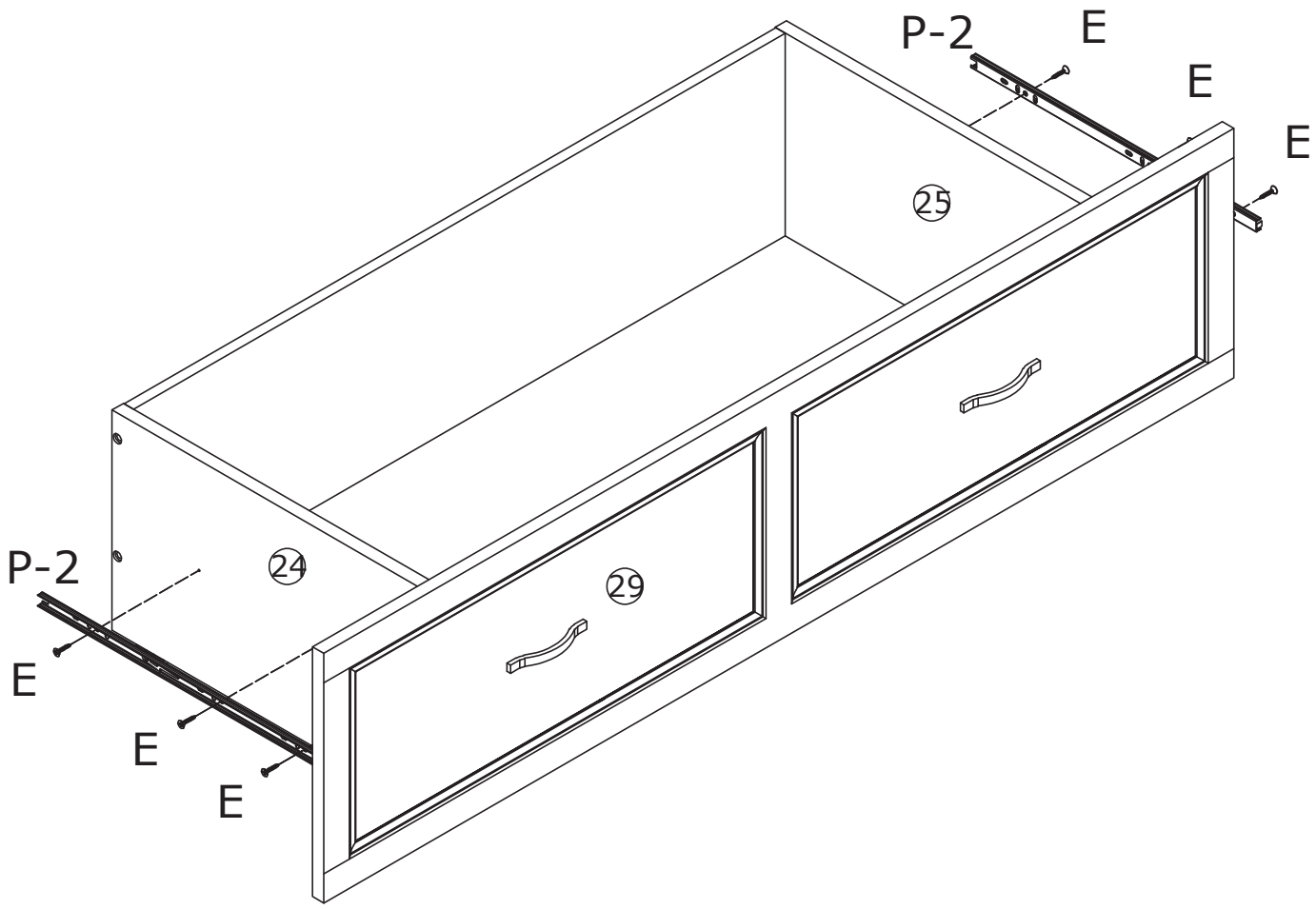

38

T x 18  Ø 3 x 16 mm	U x 18 	
--	---	---

Insert buckle(U) into back slots and fix with screw(T) as shown.

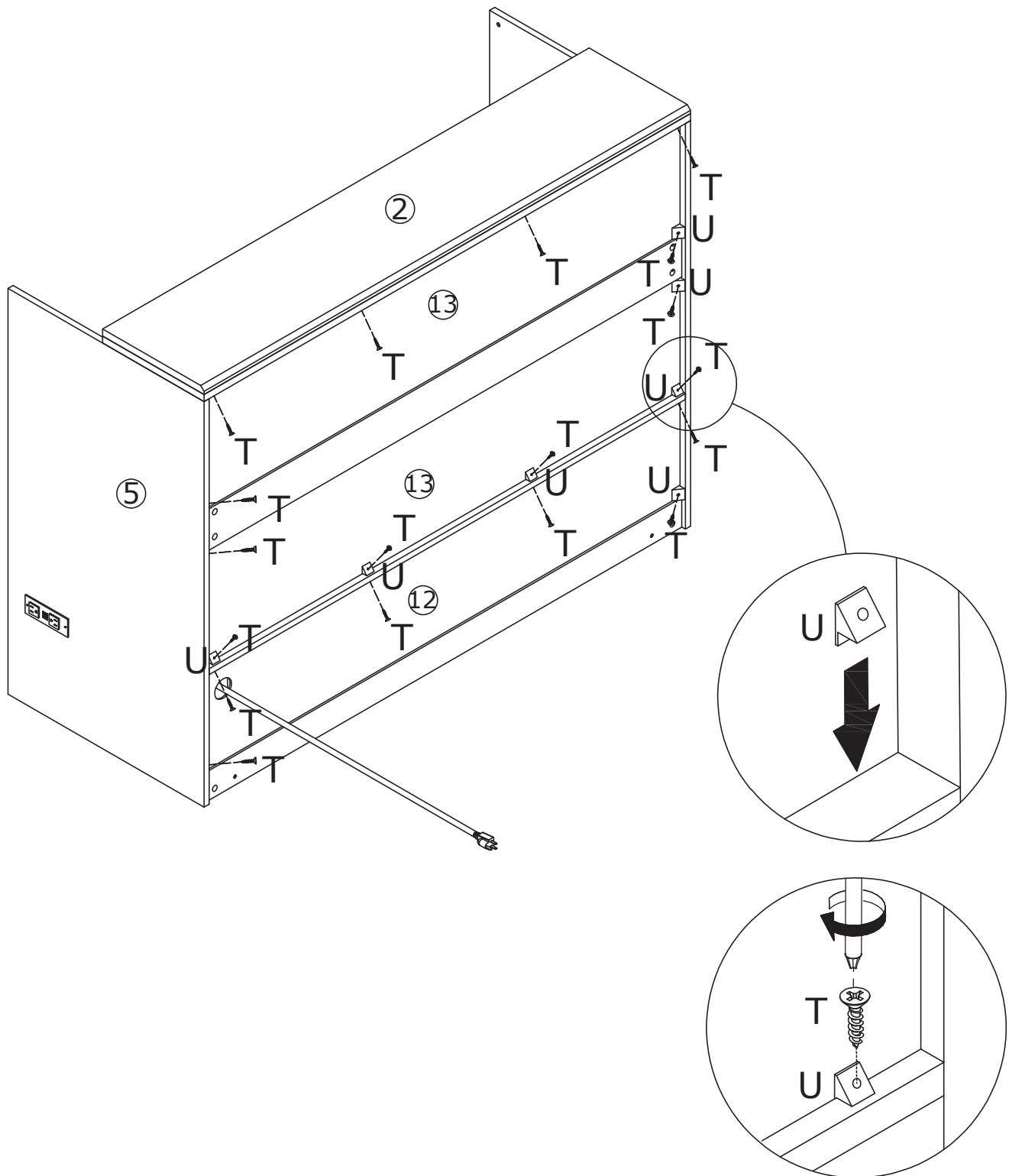

39

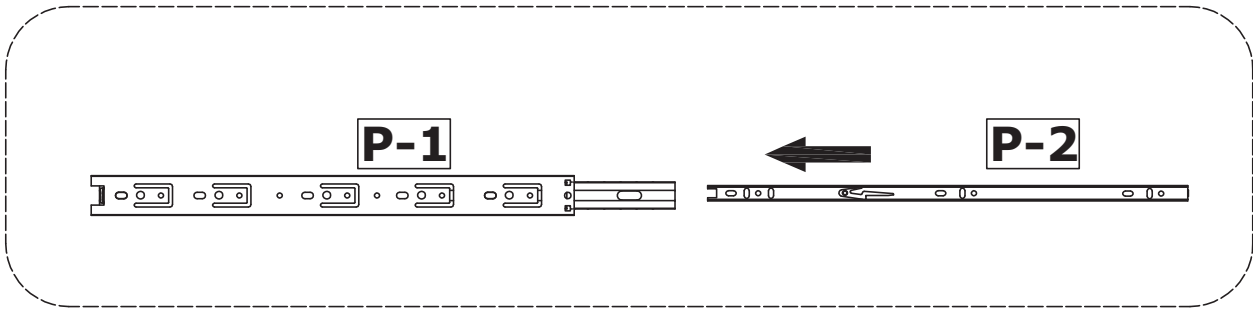

Slide runners into rails.

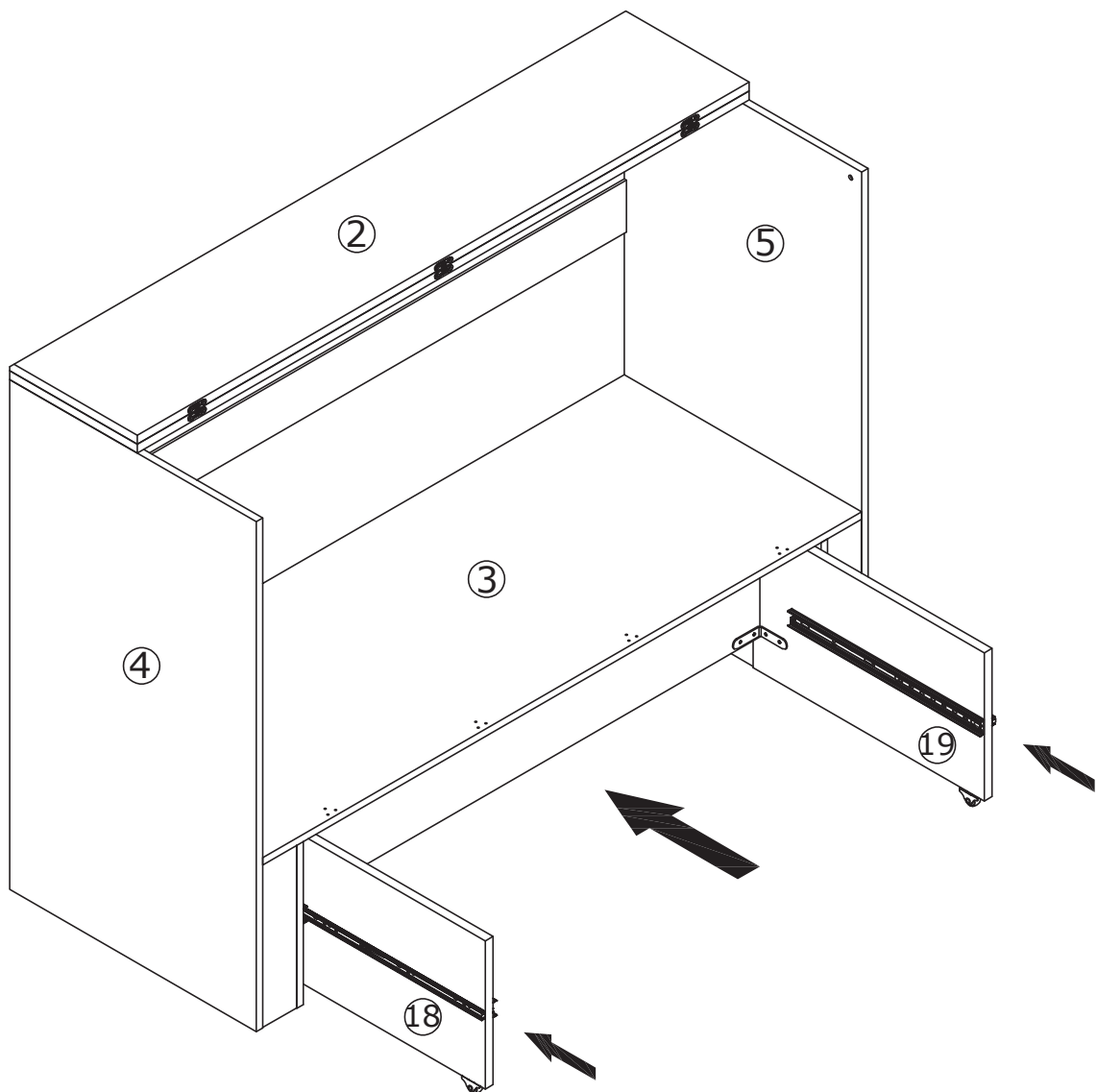

40

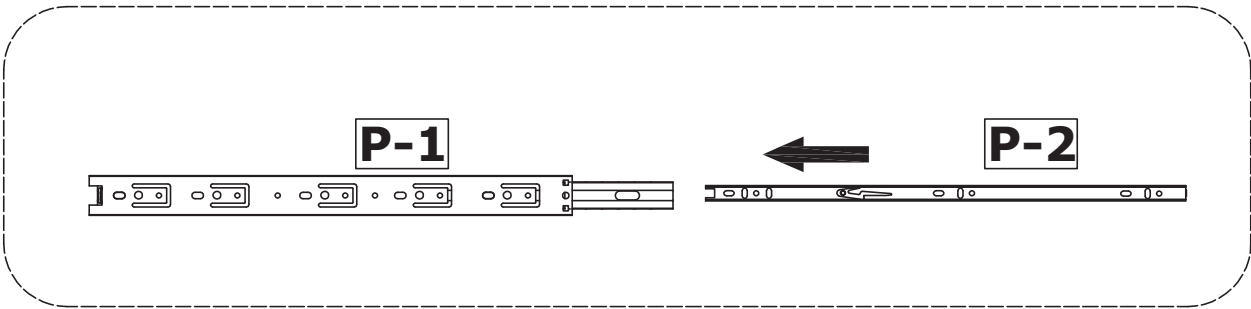

Slide runners into rails.

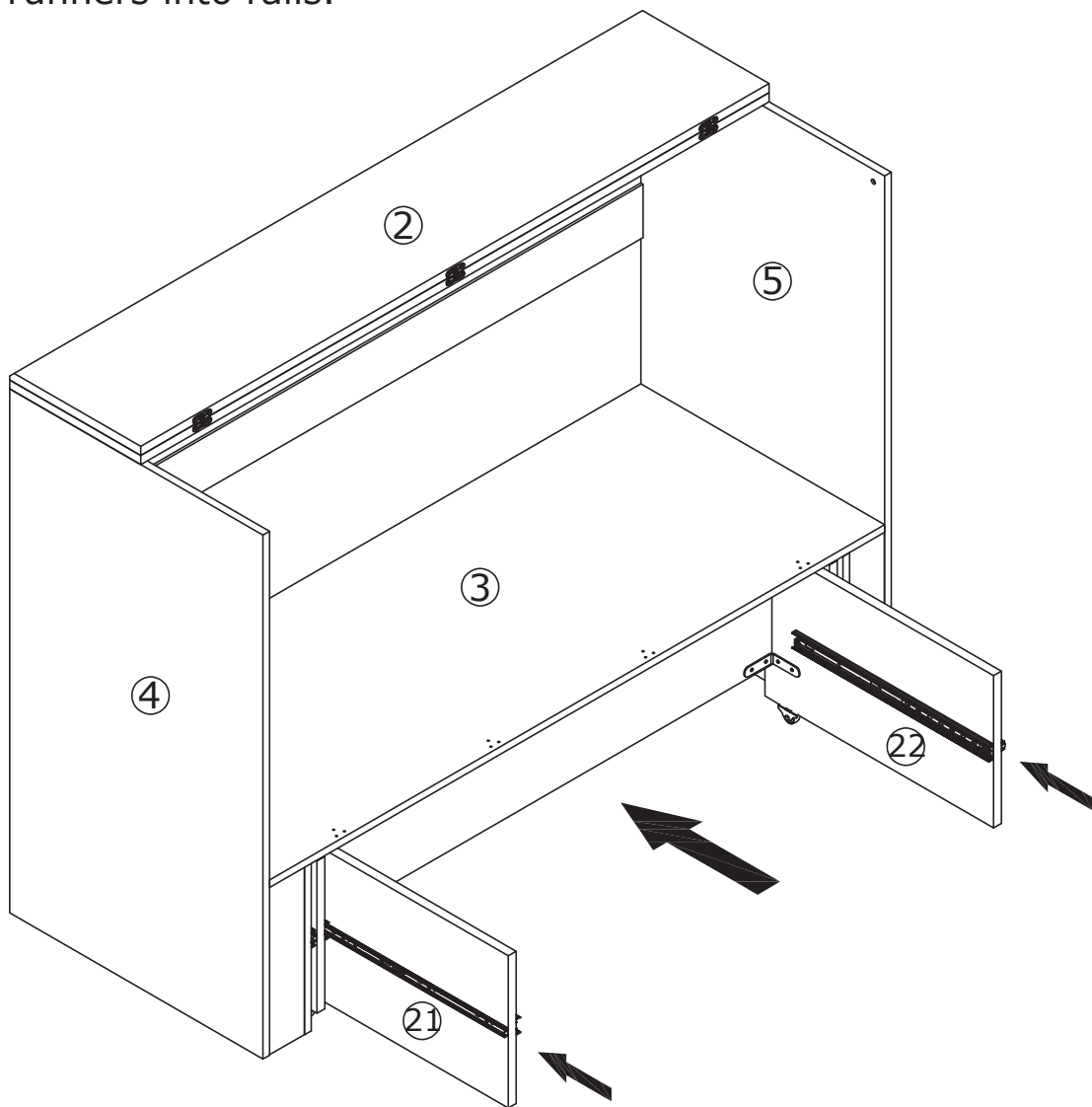

41

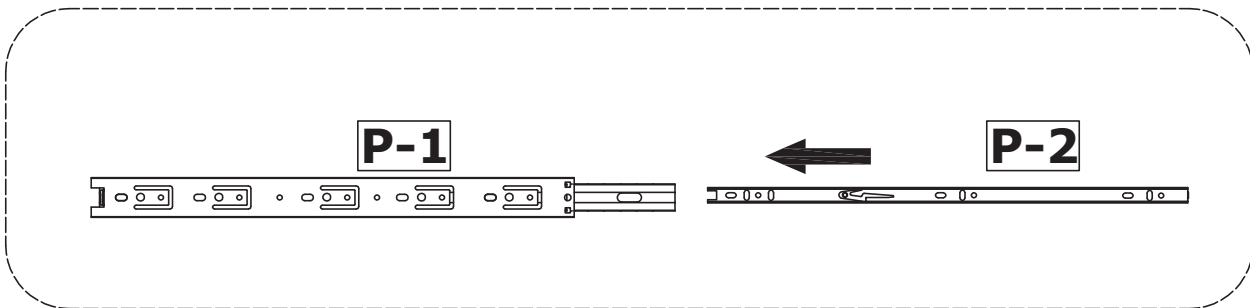

Slide runners into rails.

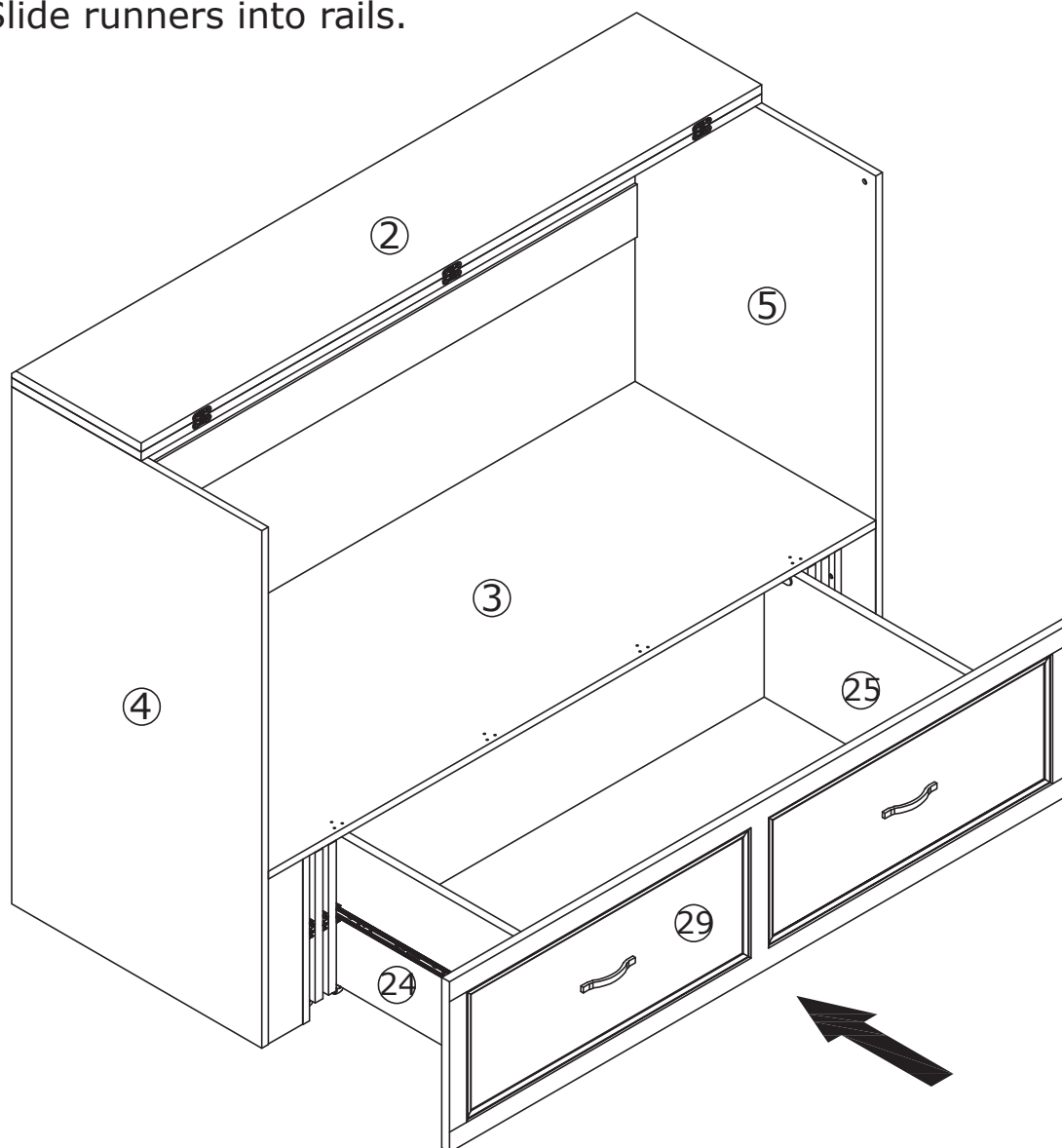

42

R x 5



S x 10

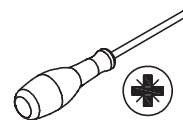

Fix handle(R) to plate 16 and 17 with screw(S) as shown.

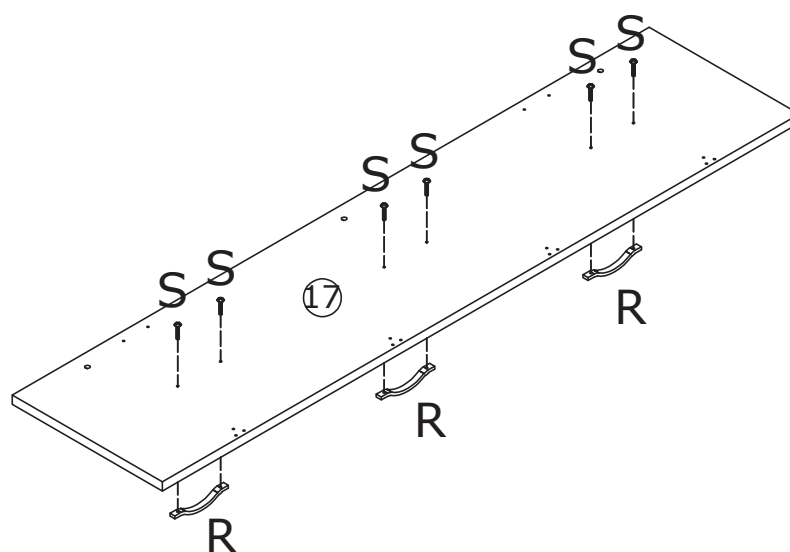
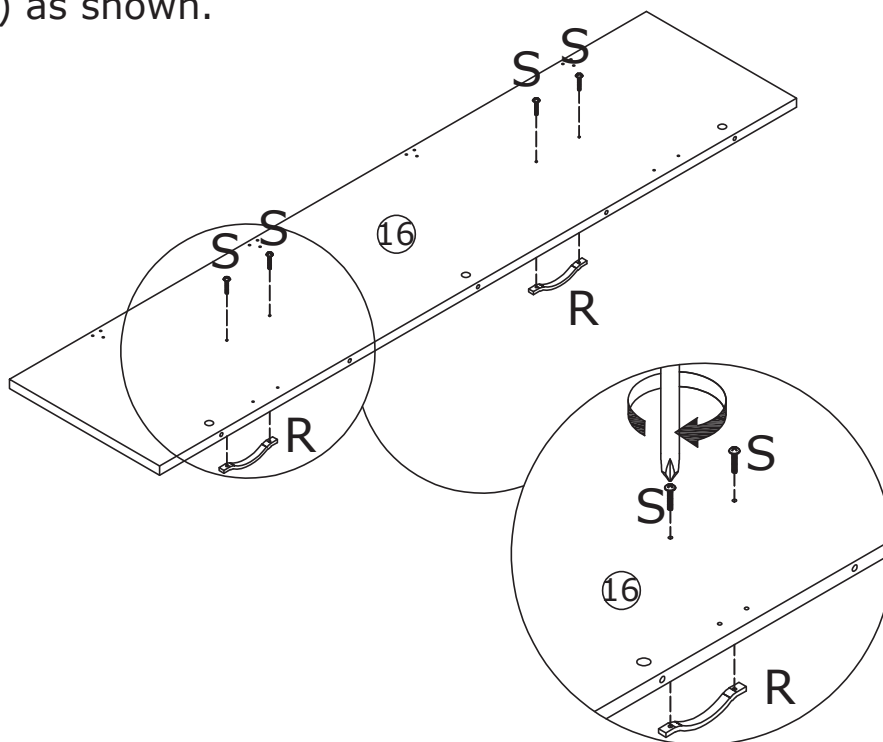

43

K x 6



X x 6

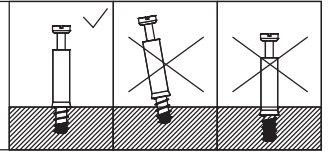
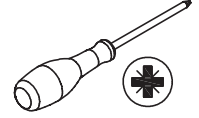
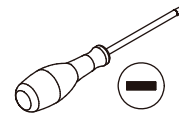

Insert nut(K) into plate 17 and 14 at first.

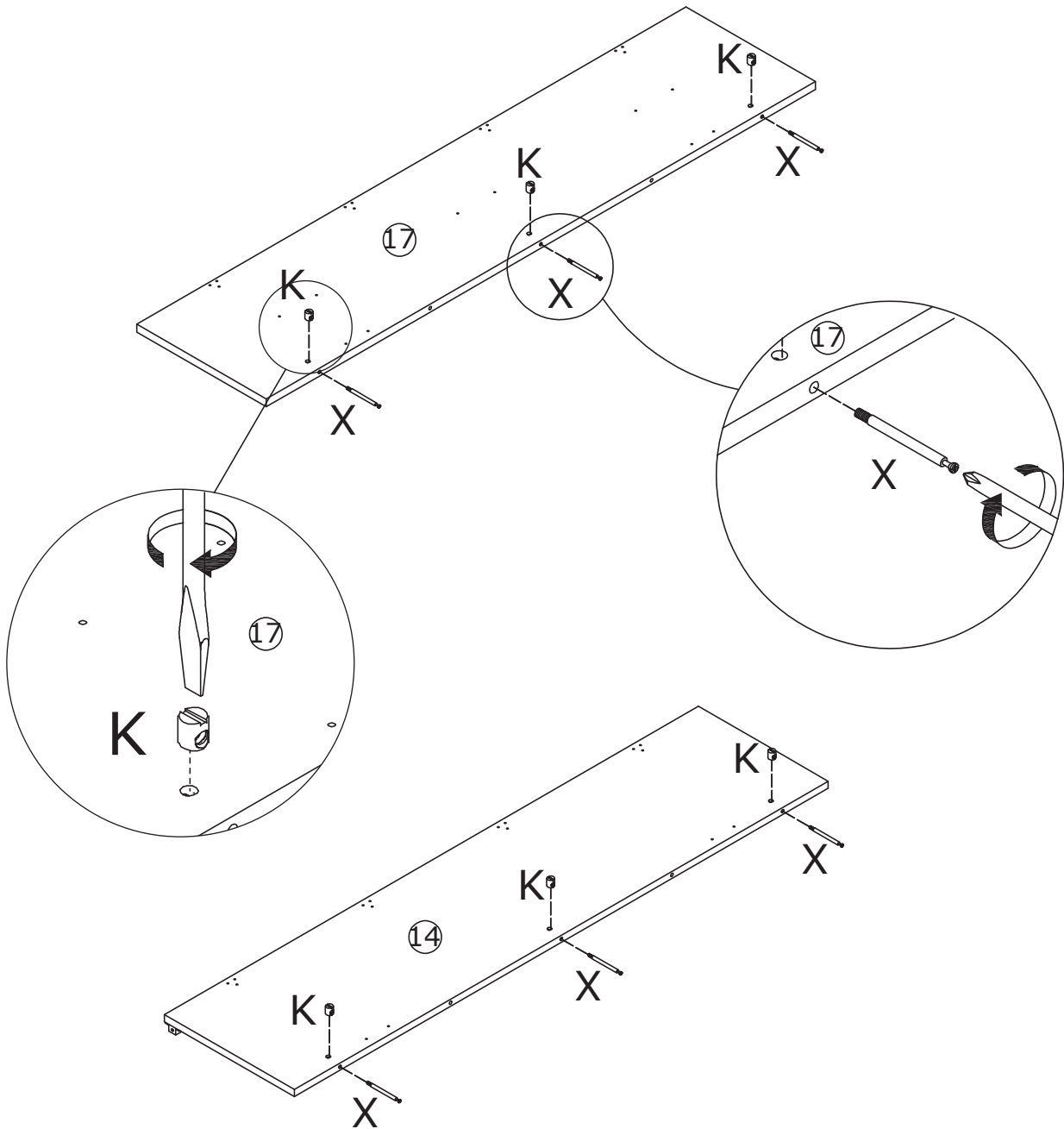

Insert quickfit screw(X) into as shown.

44

B x 6



∅ 15 x 10 mm

Y x 4



∅ 8 x 60 mm

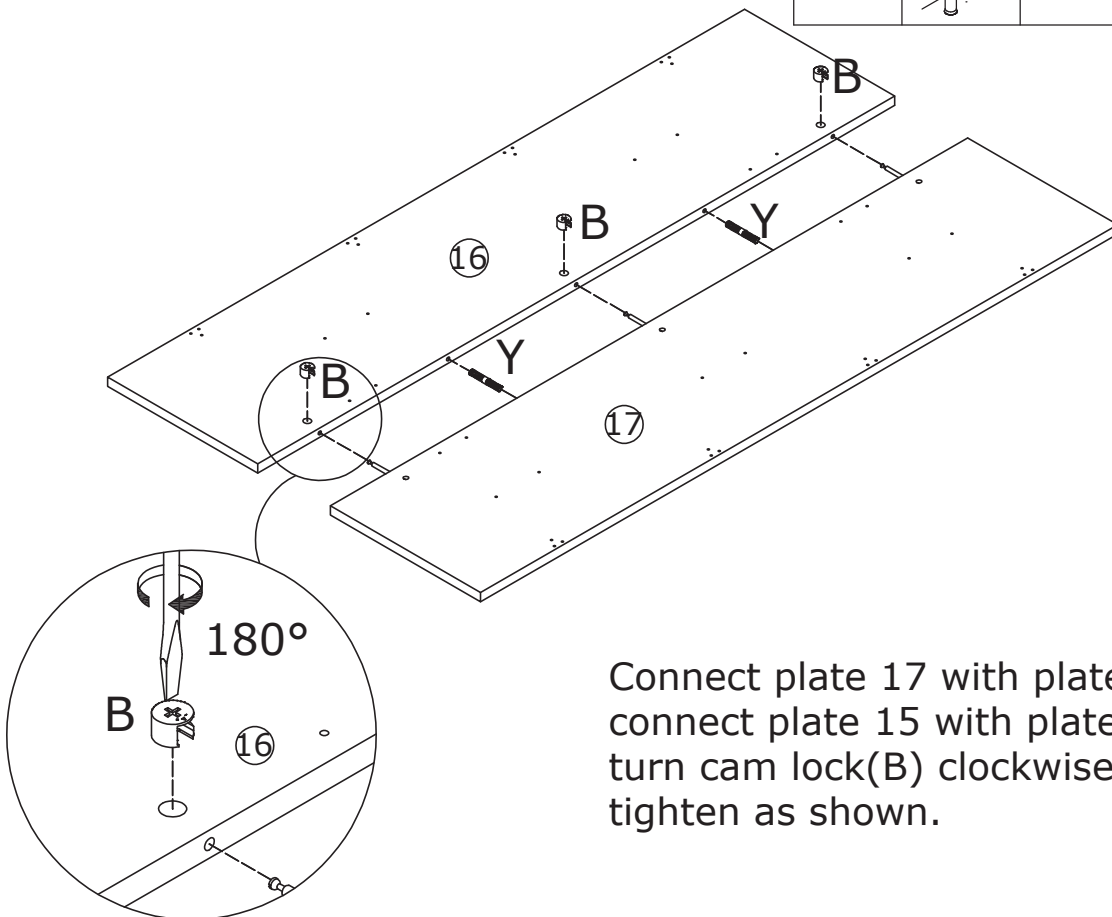
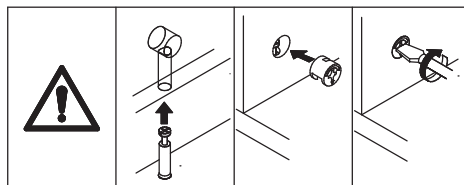

Connect plate 17 with plate 16; connect plate 15 with plate 14, turn cam lock(B) clockwise to tighten as shown.

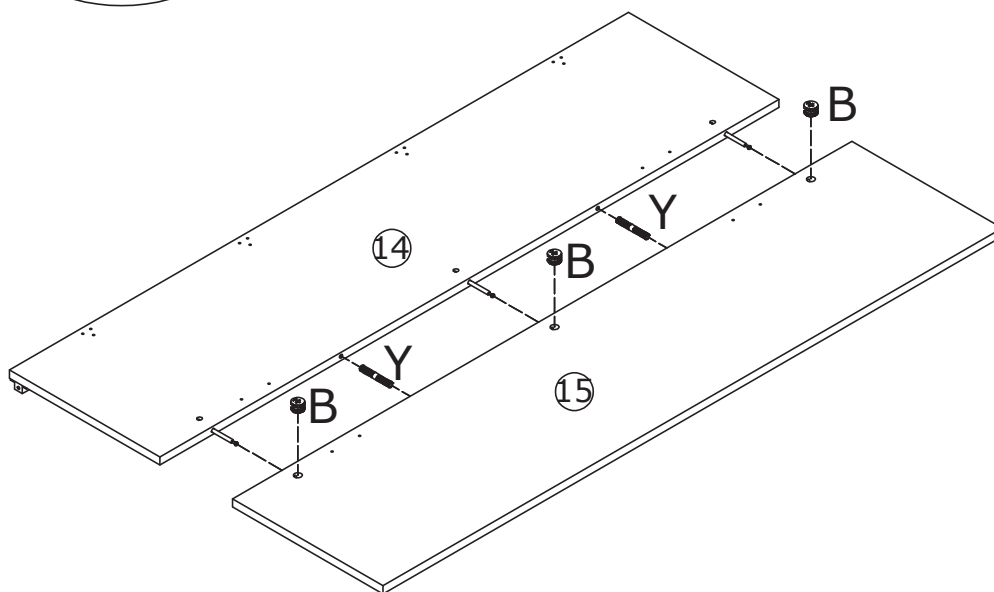

45

Z x 4



E x 16



Ø 3.5 x 12 mm

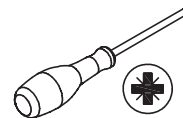

Use part(Z) to fix plate 16 and 17 together with screw(E) as shown.

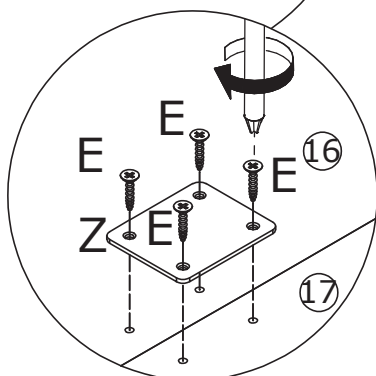
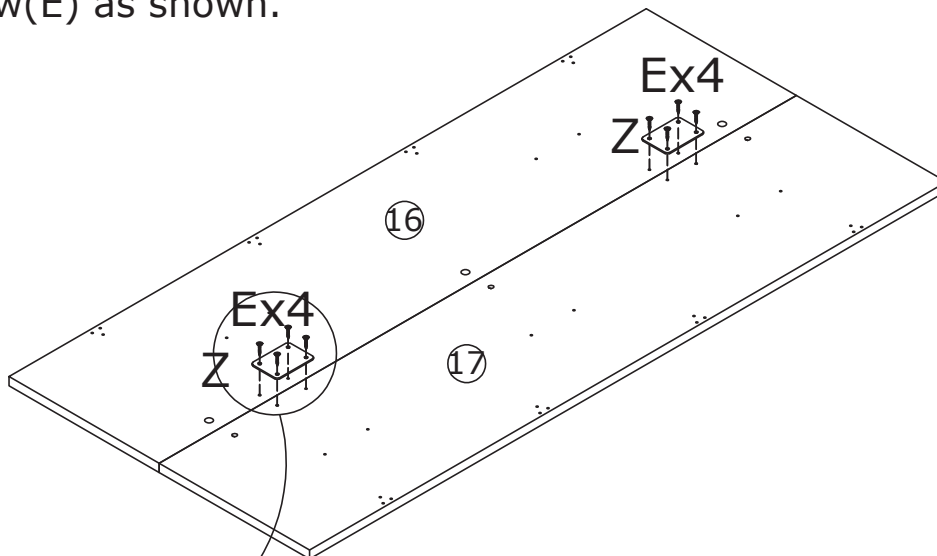

Use part(Z) to fix plate 14 and 15 together with screw(E) as shown.

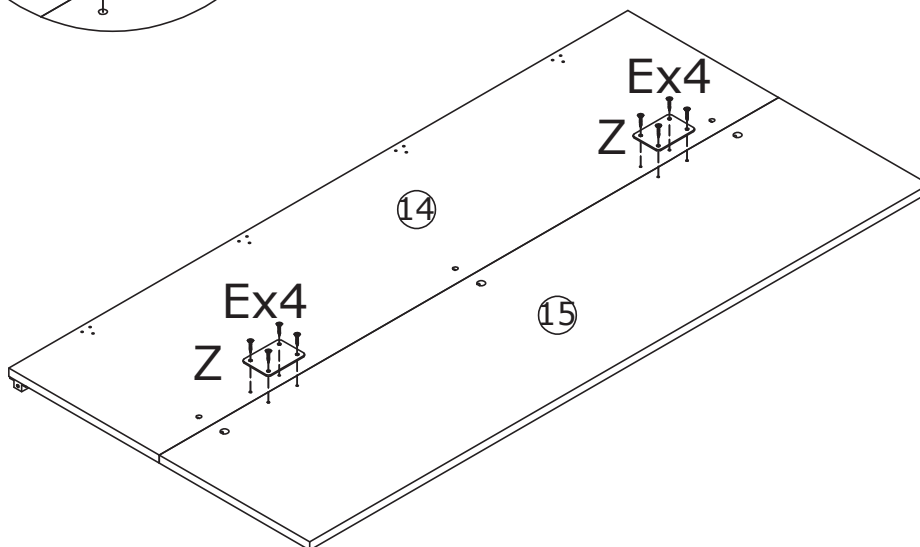

46

AS x 2

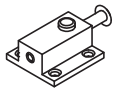

E x 8



Ø 3.5 x 12 mm

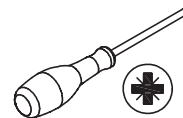

Fix part(AS) to plate 14 with screw(E) as shown.

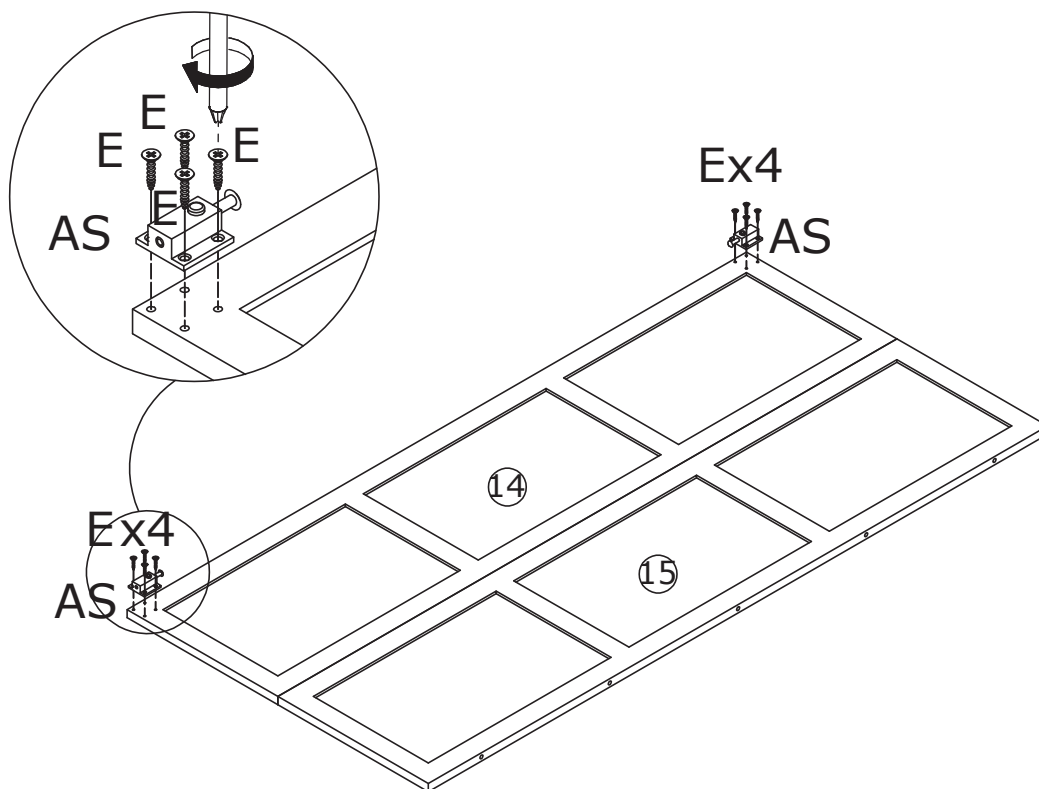

47

Pull out drawer.

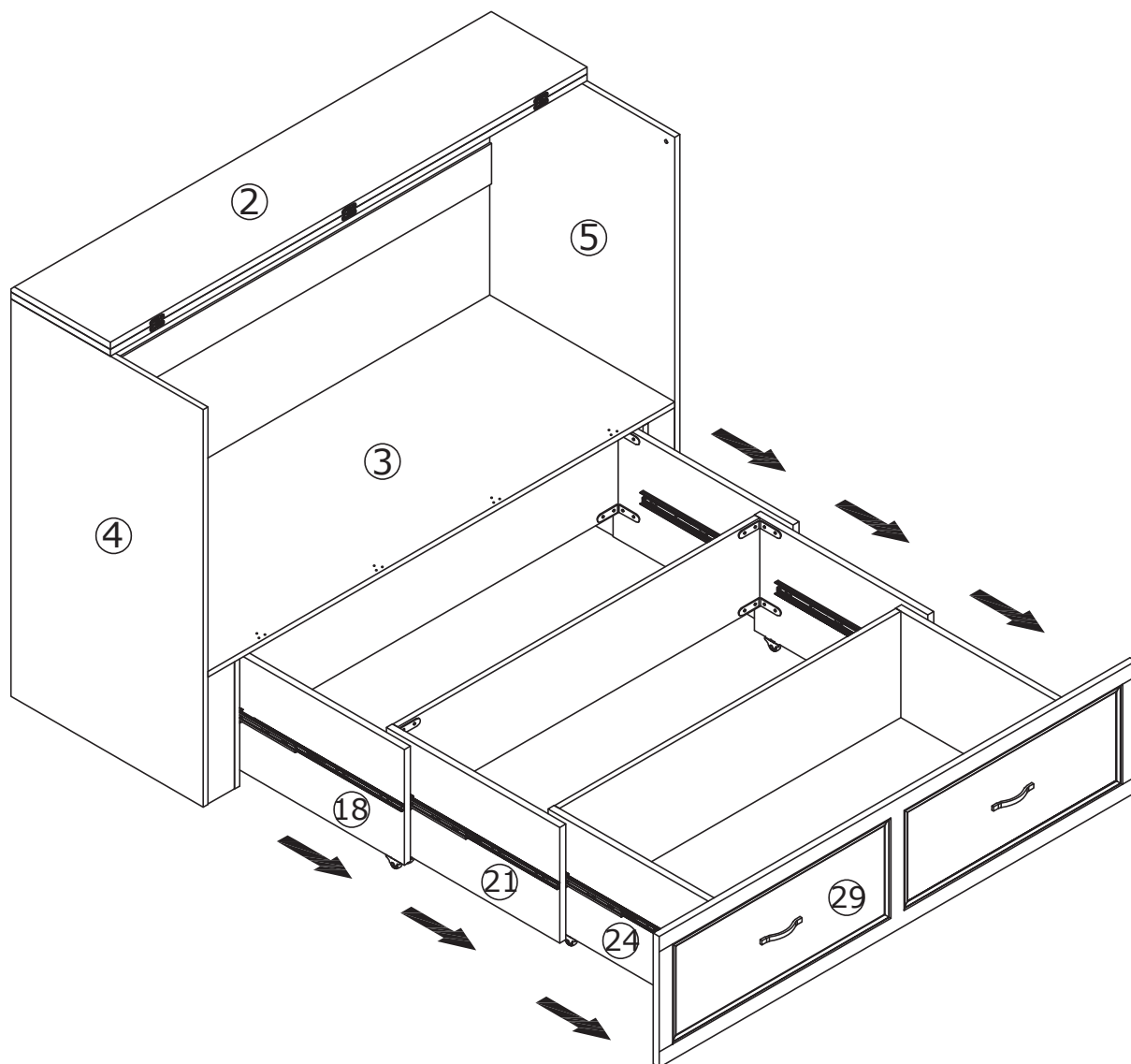

48

BS x 4



E x 24



∅ 3.5 x 12 mm

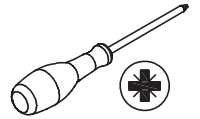

Use hinge(BS) to fix plate 16 and 3 together with screw(E) as shown.

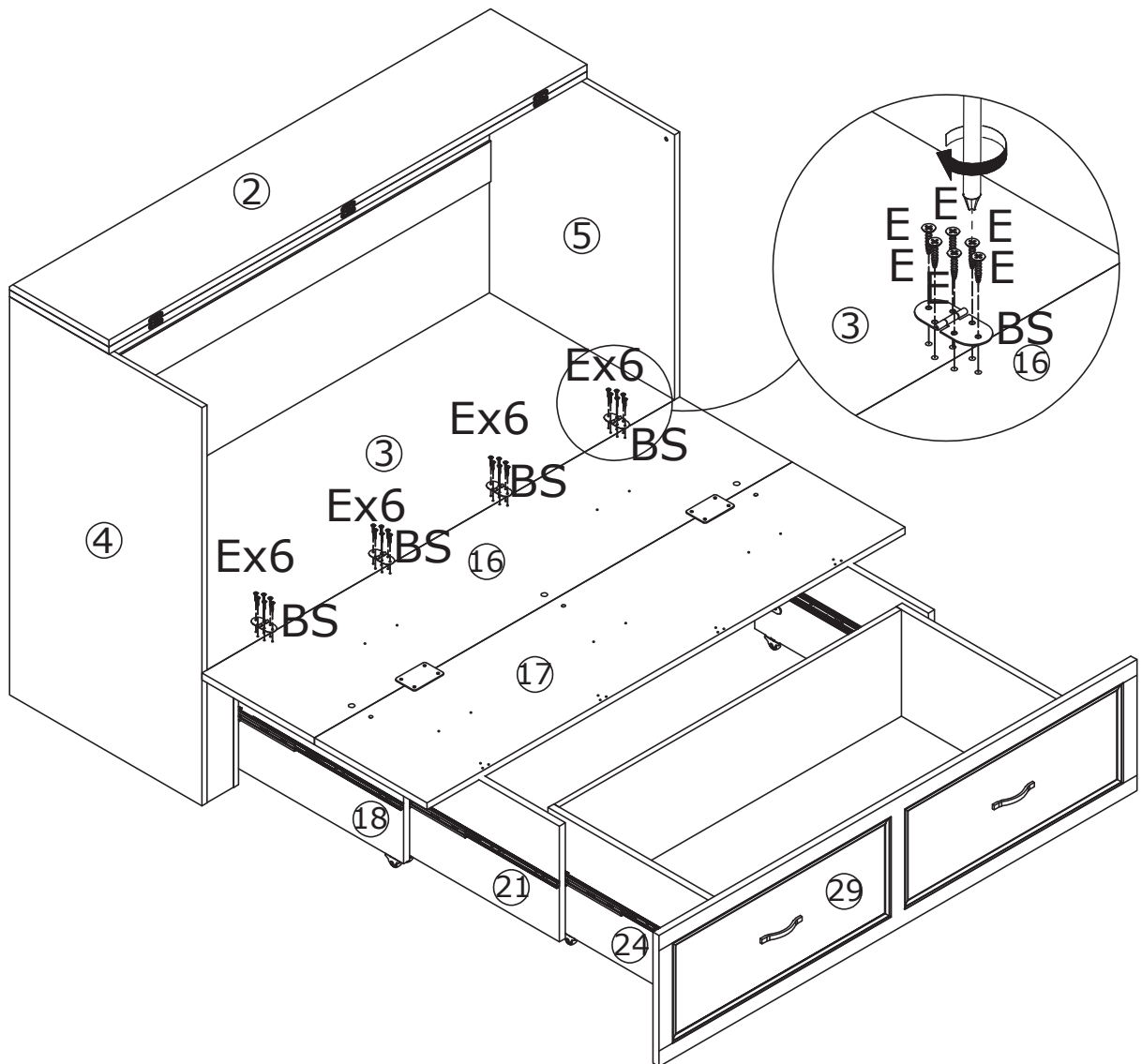

49

BS x 4



E x 24



Ø 3.5 x 12 mm

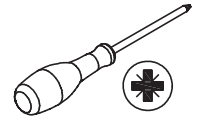

Use hinge(BS) to fix plate 17 and 14 together with screw(E) as shown.

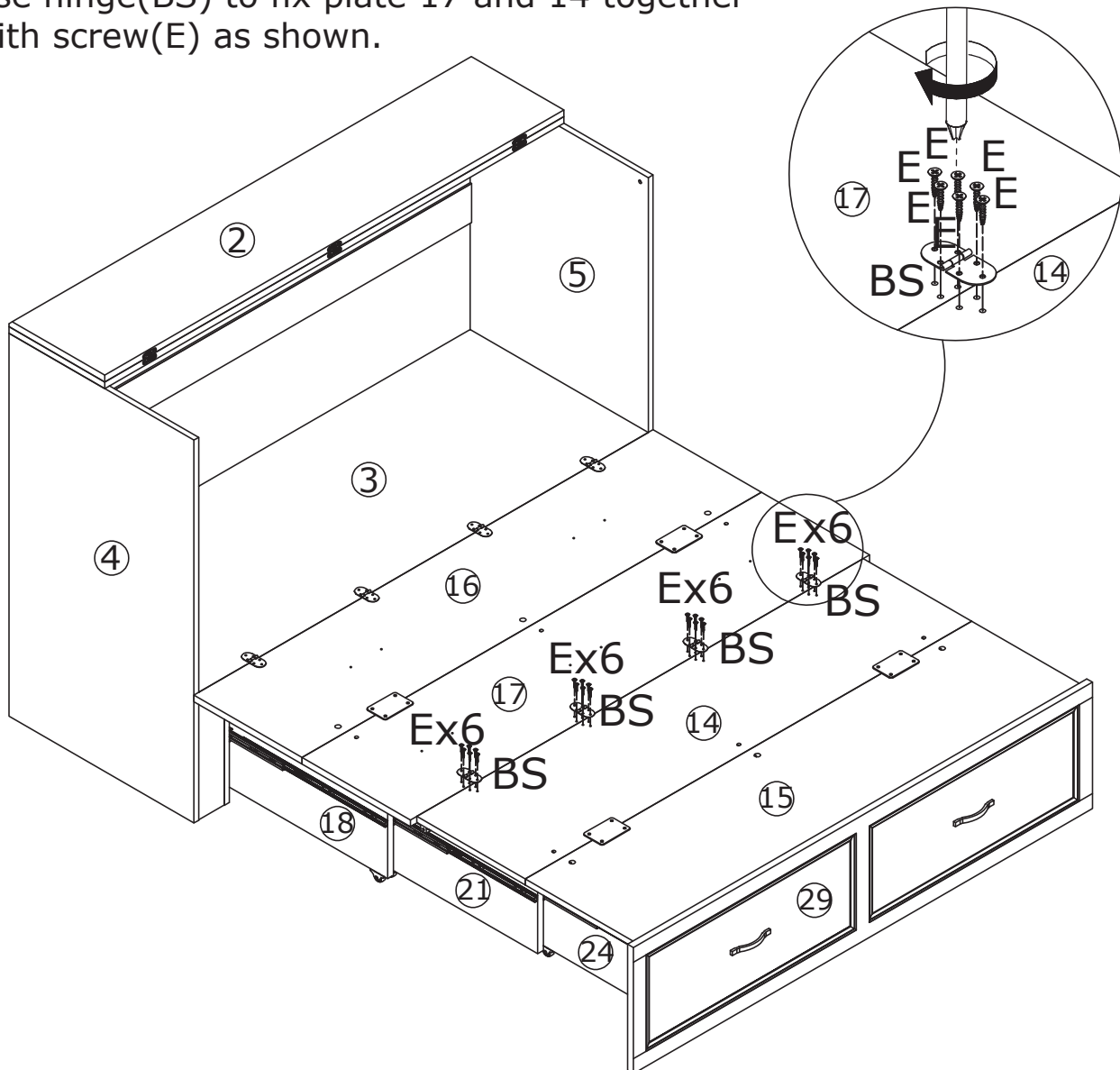

50

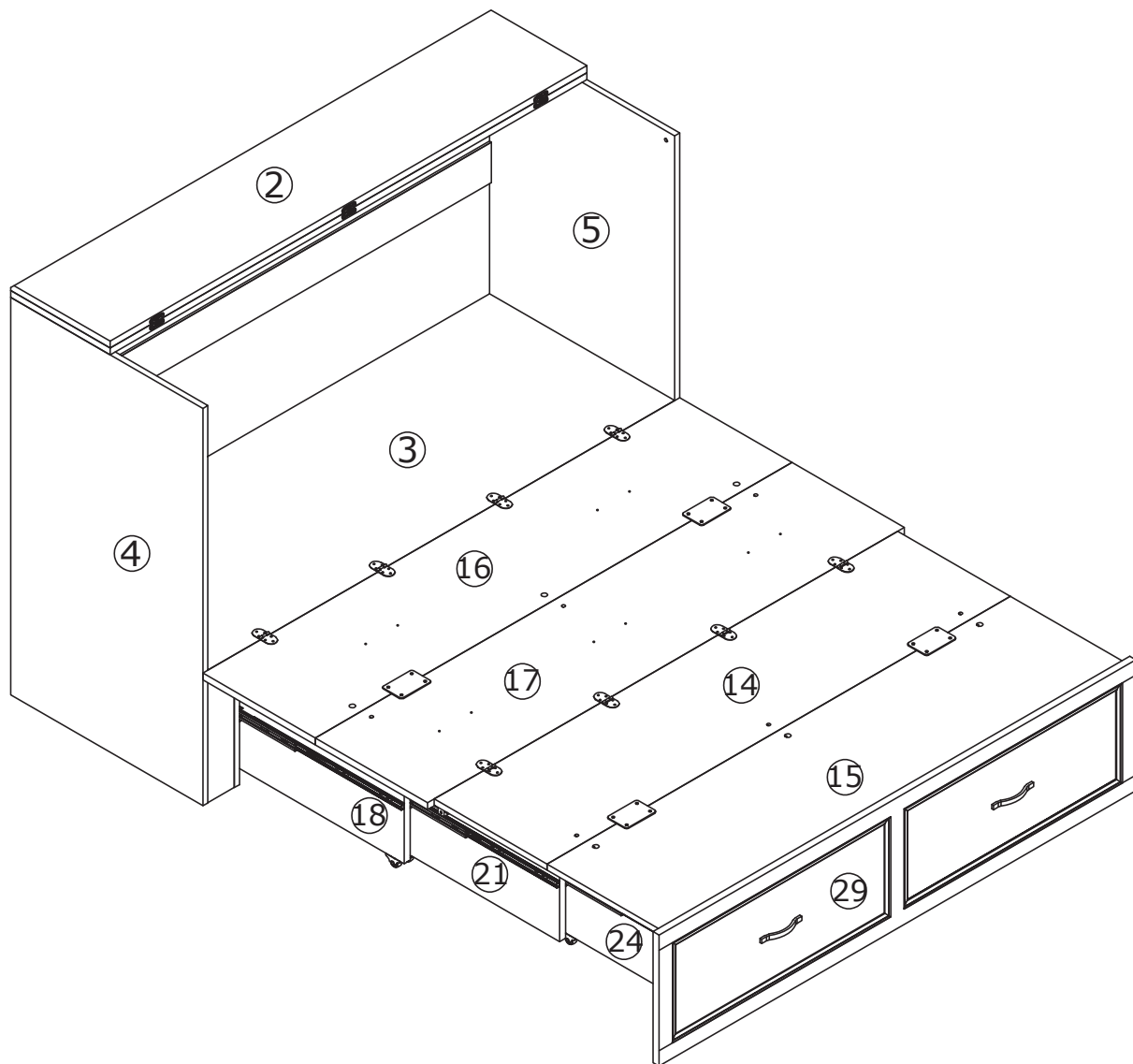

51

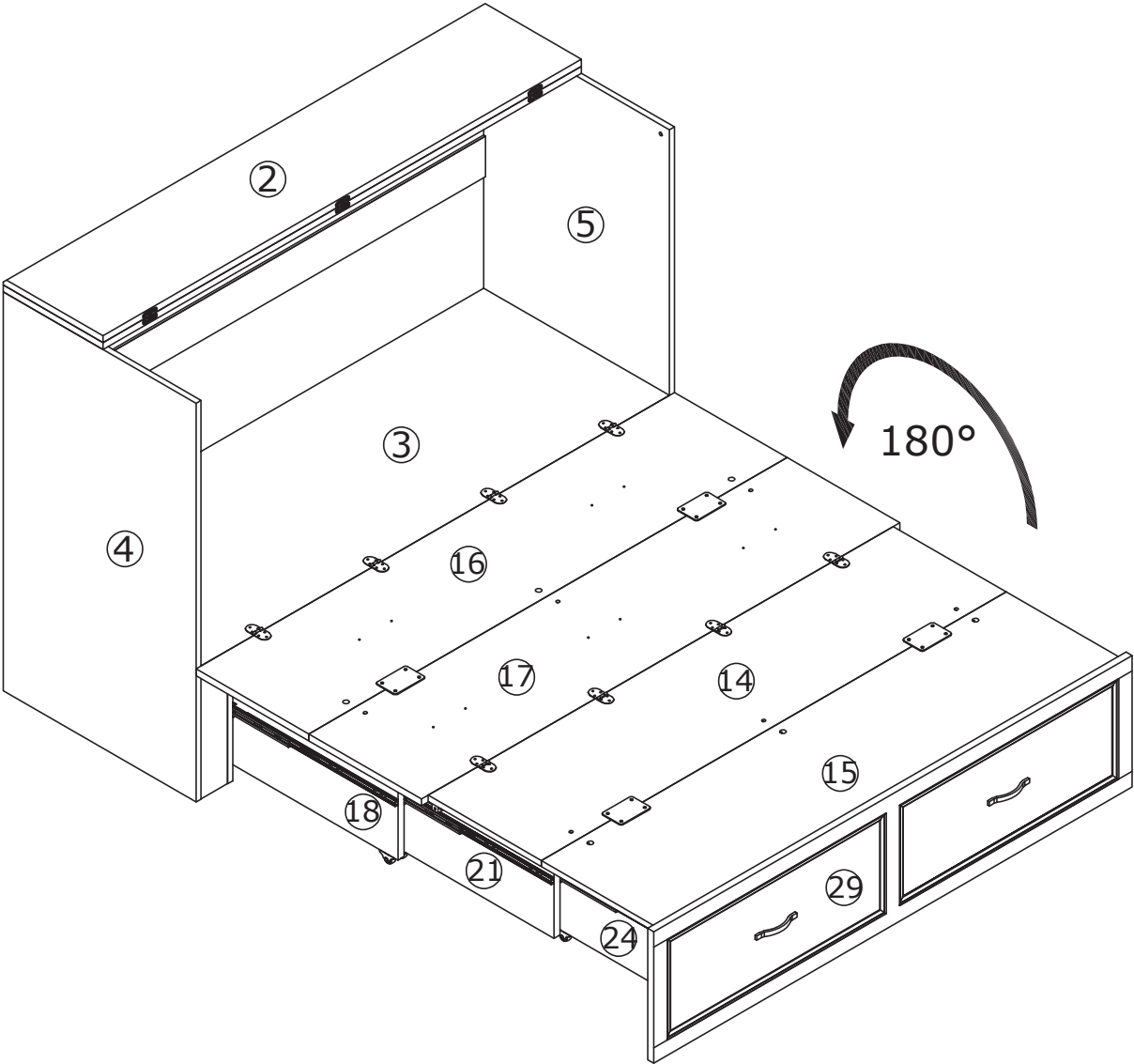
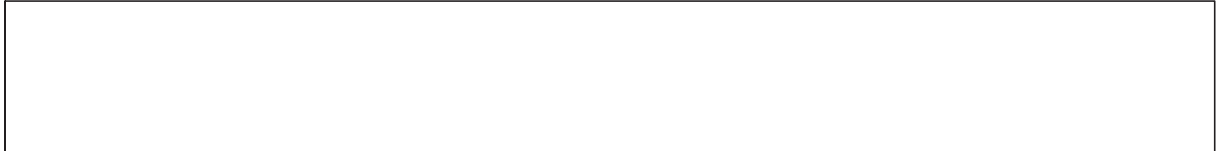

52

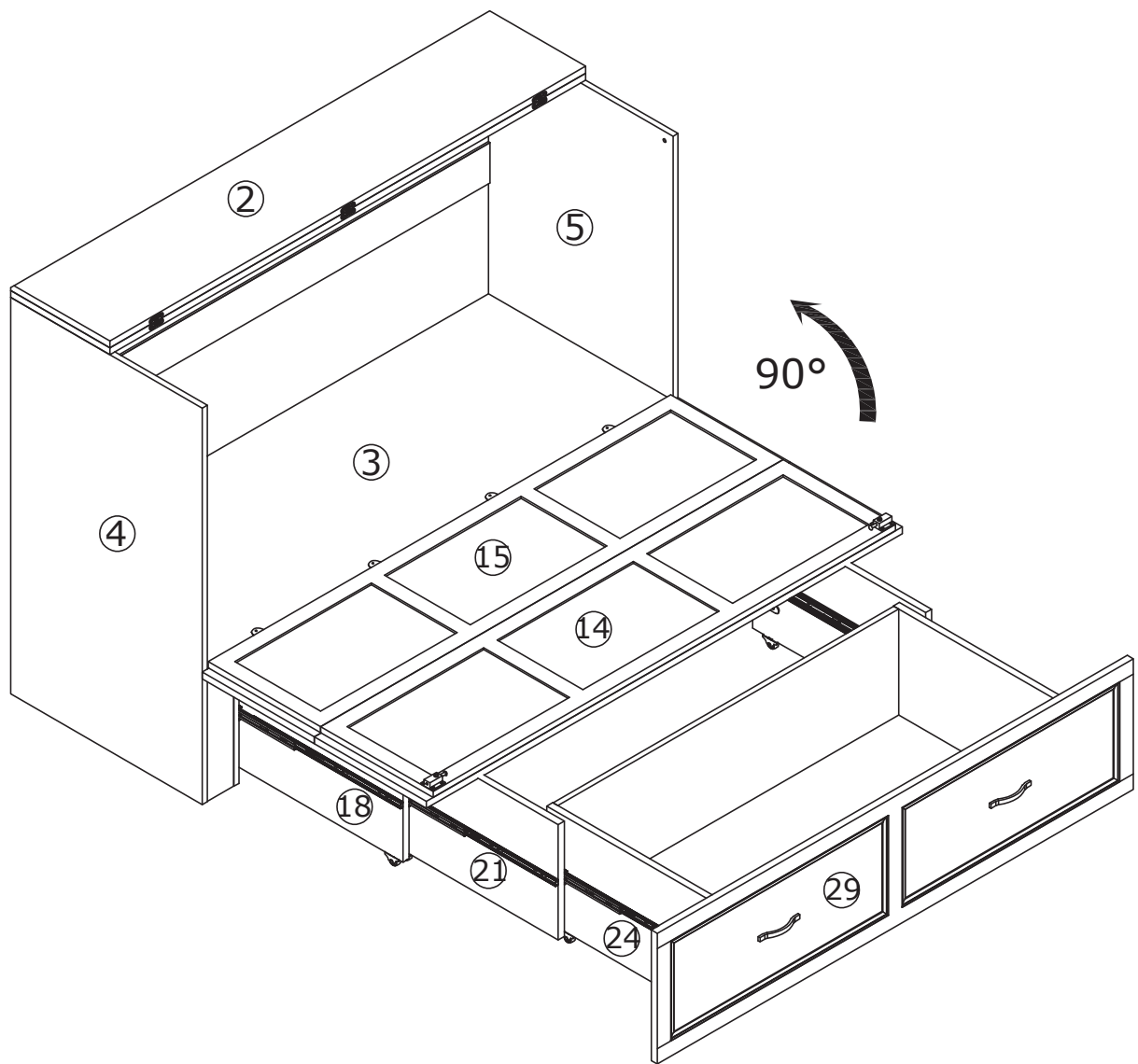
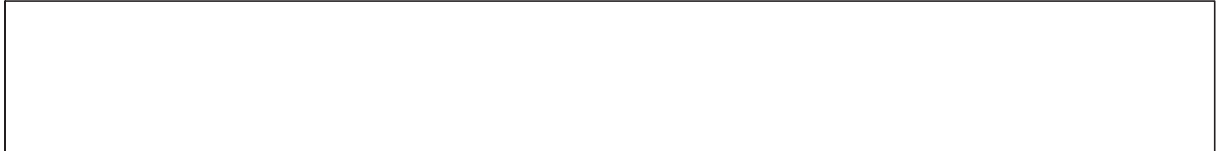

53

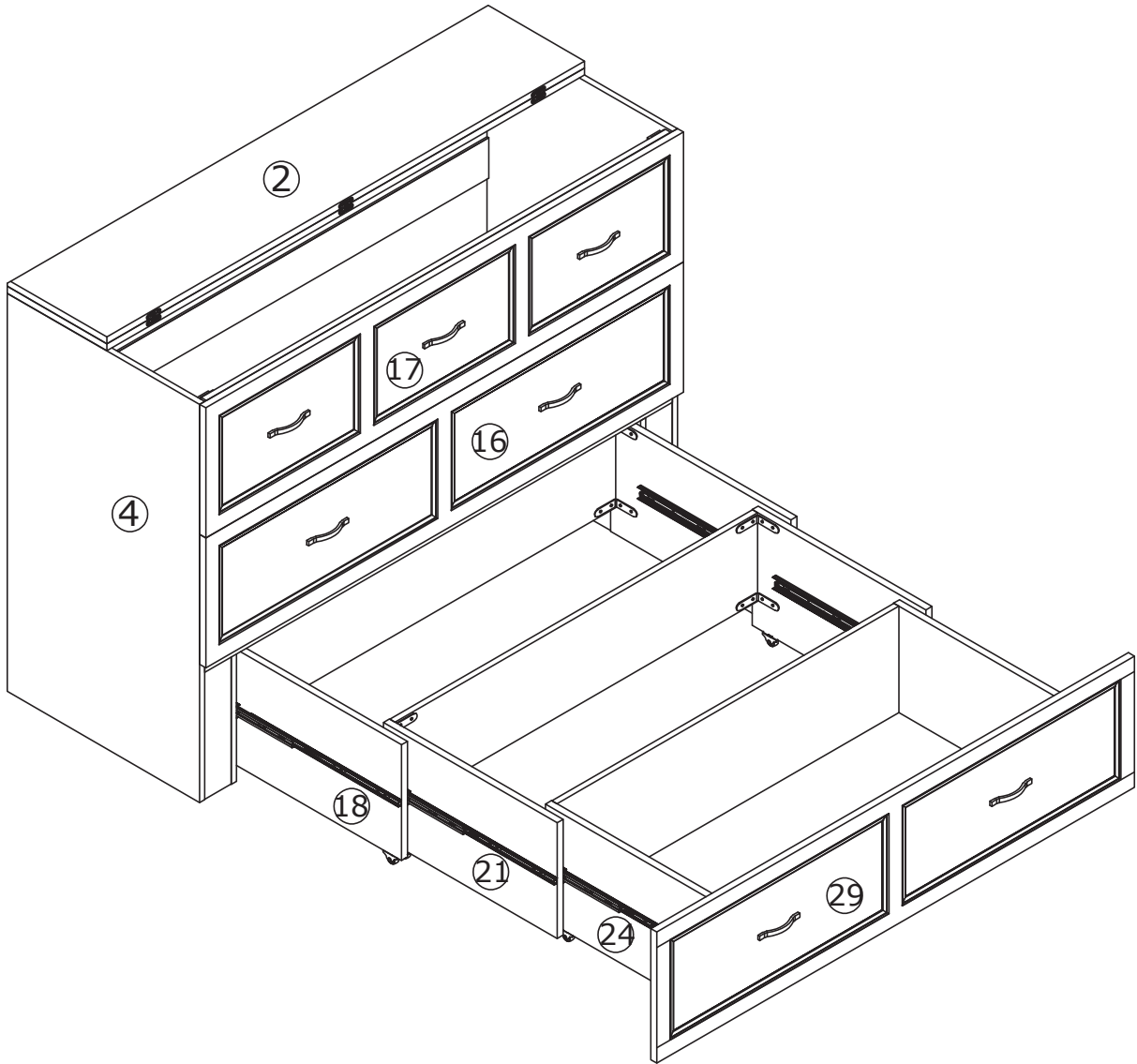
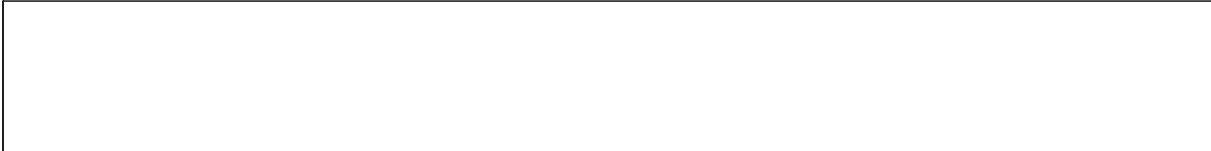

54

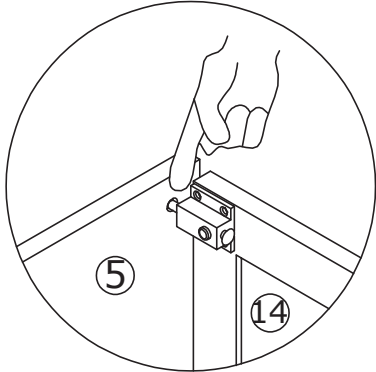
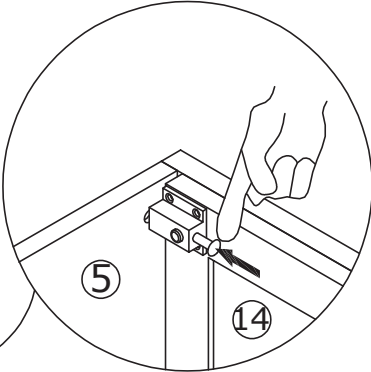
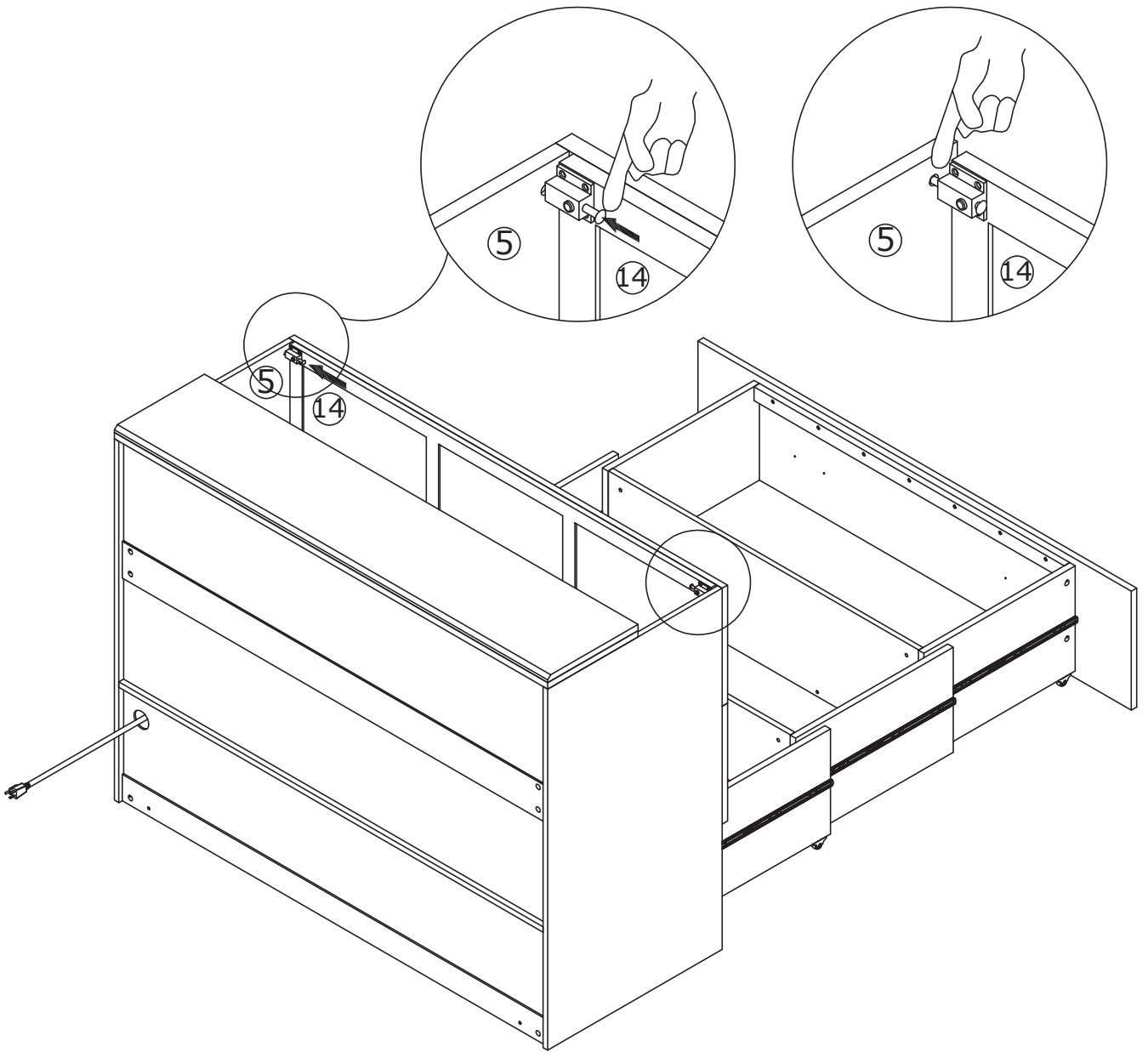

55

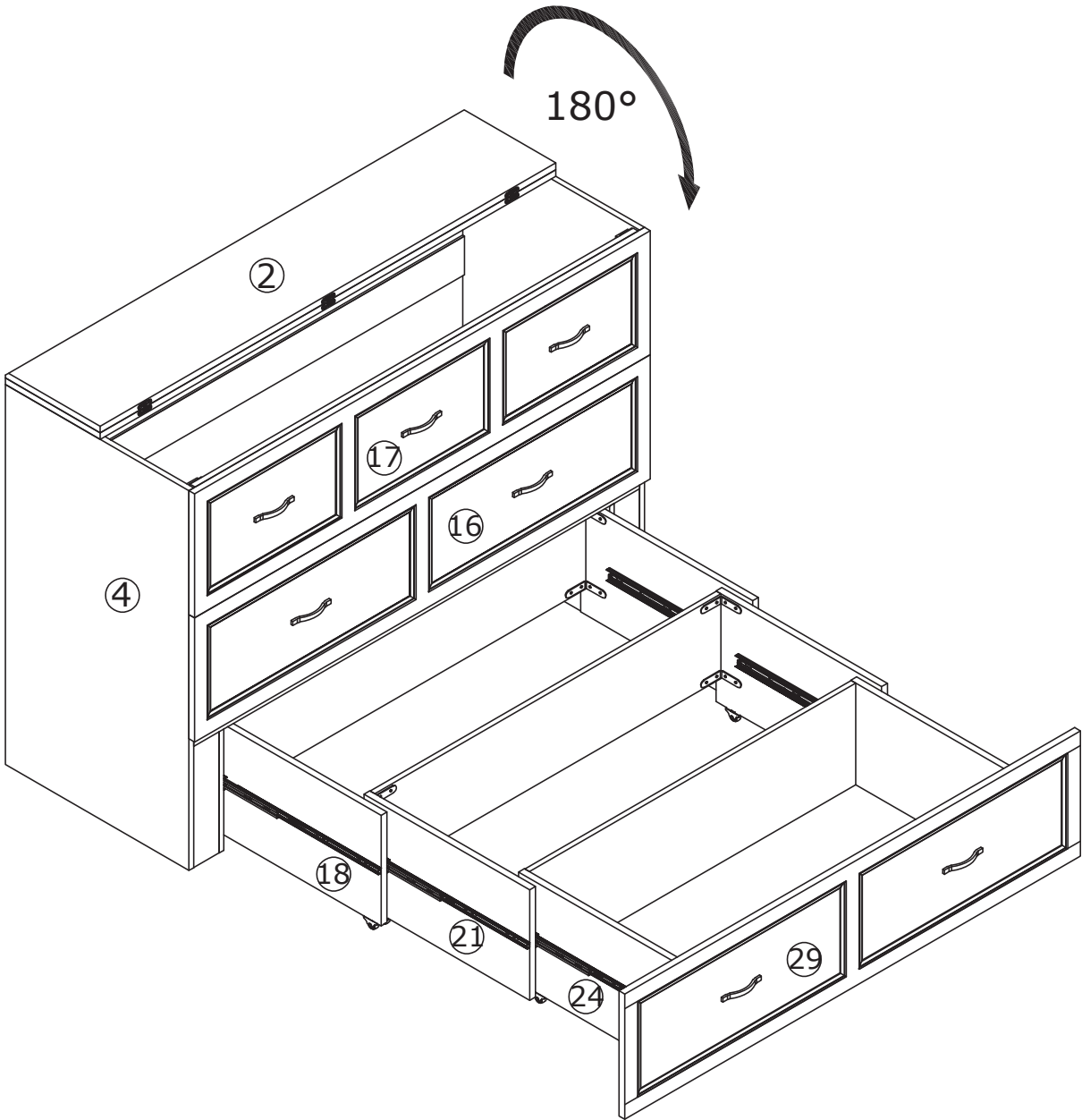
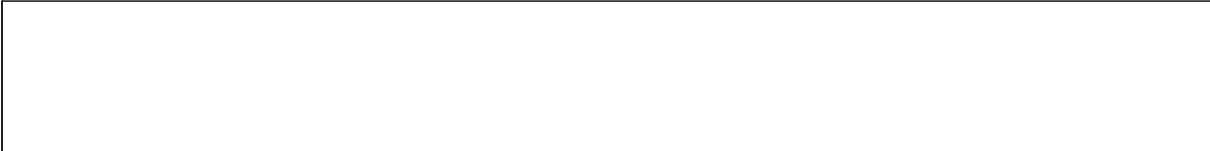

56

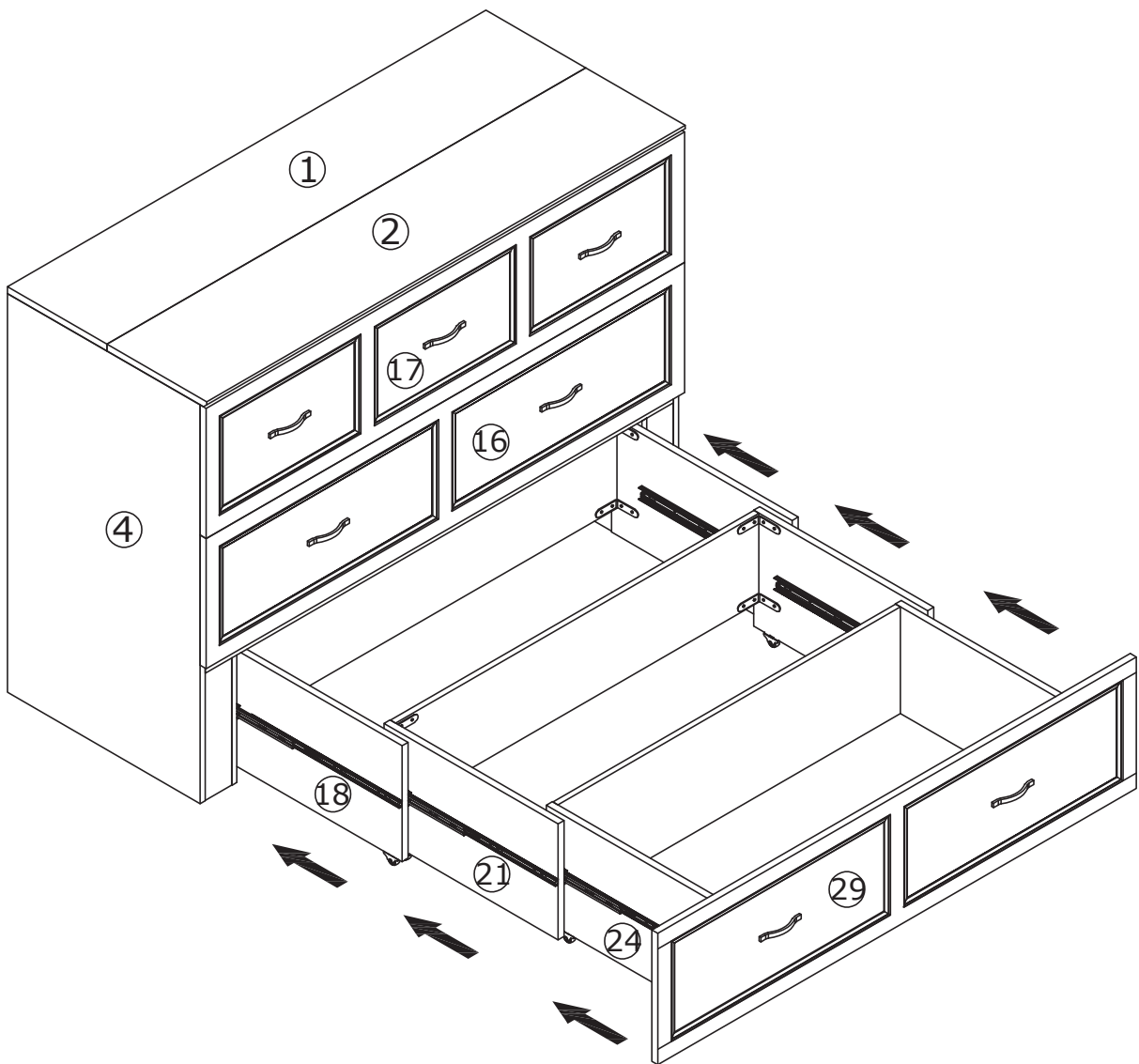
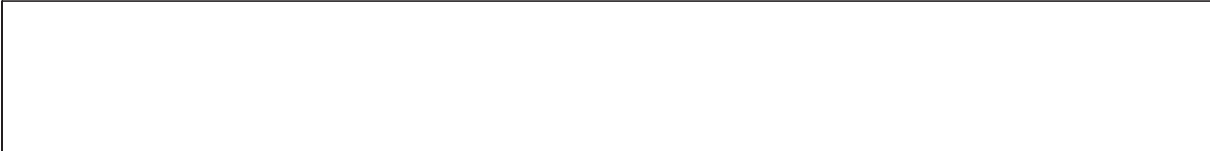

57

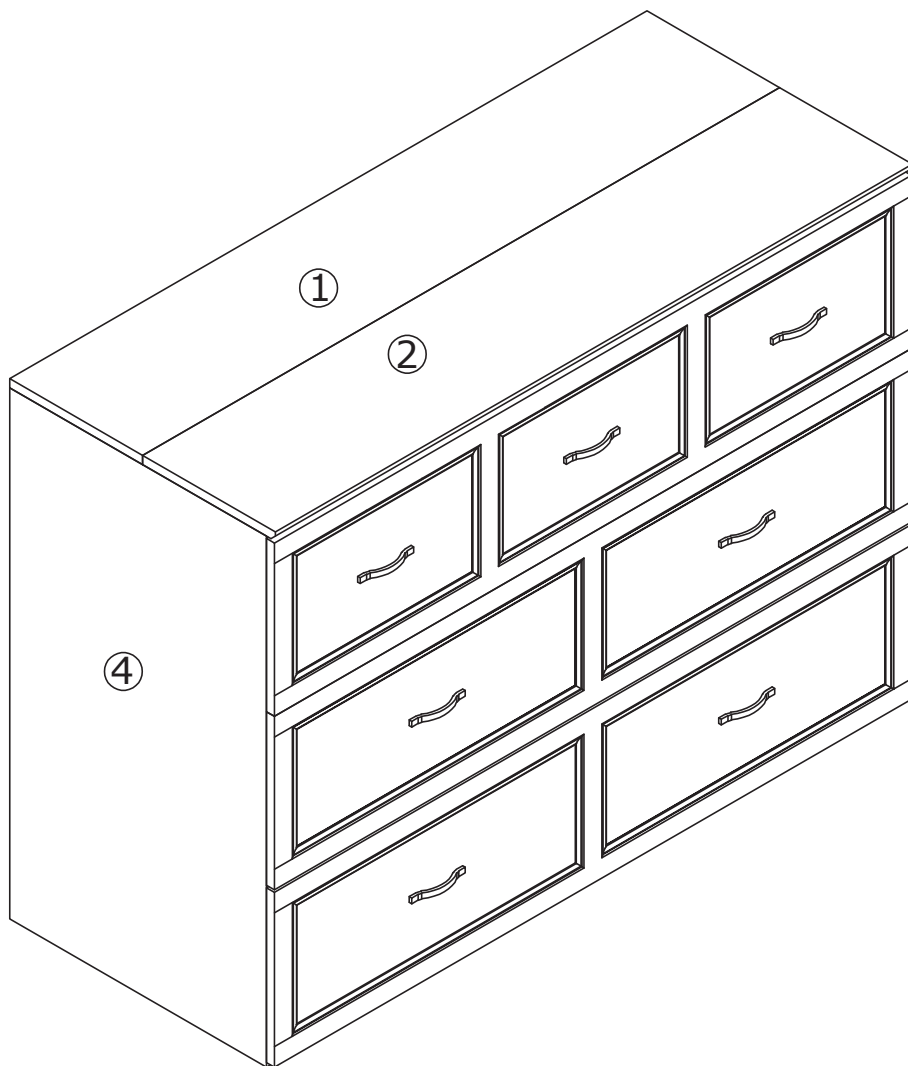
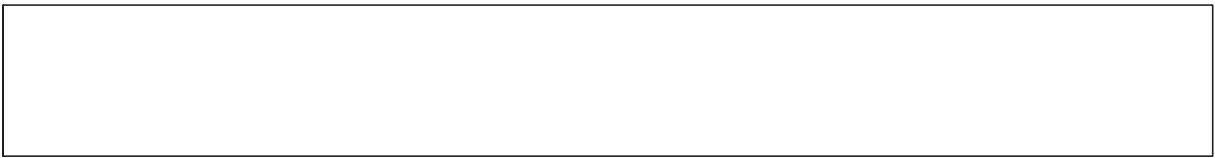

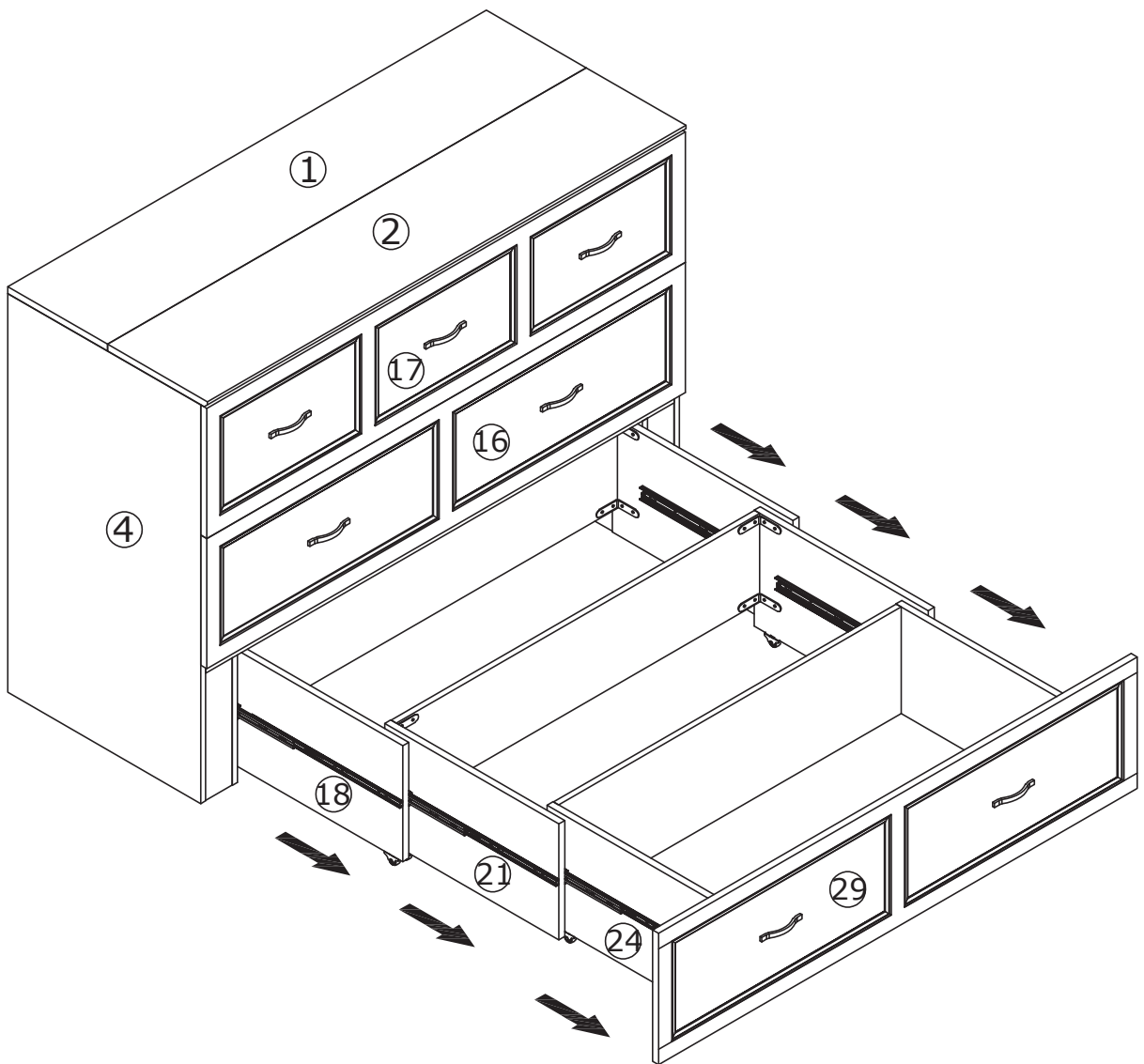
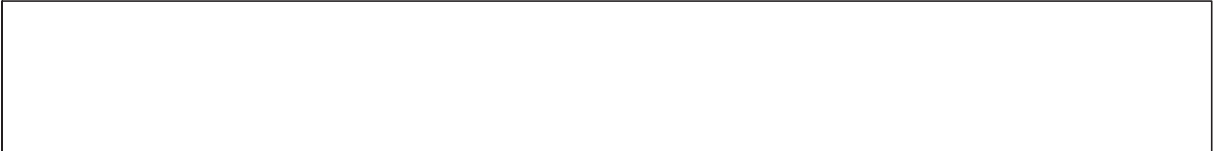

59

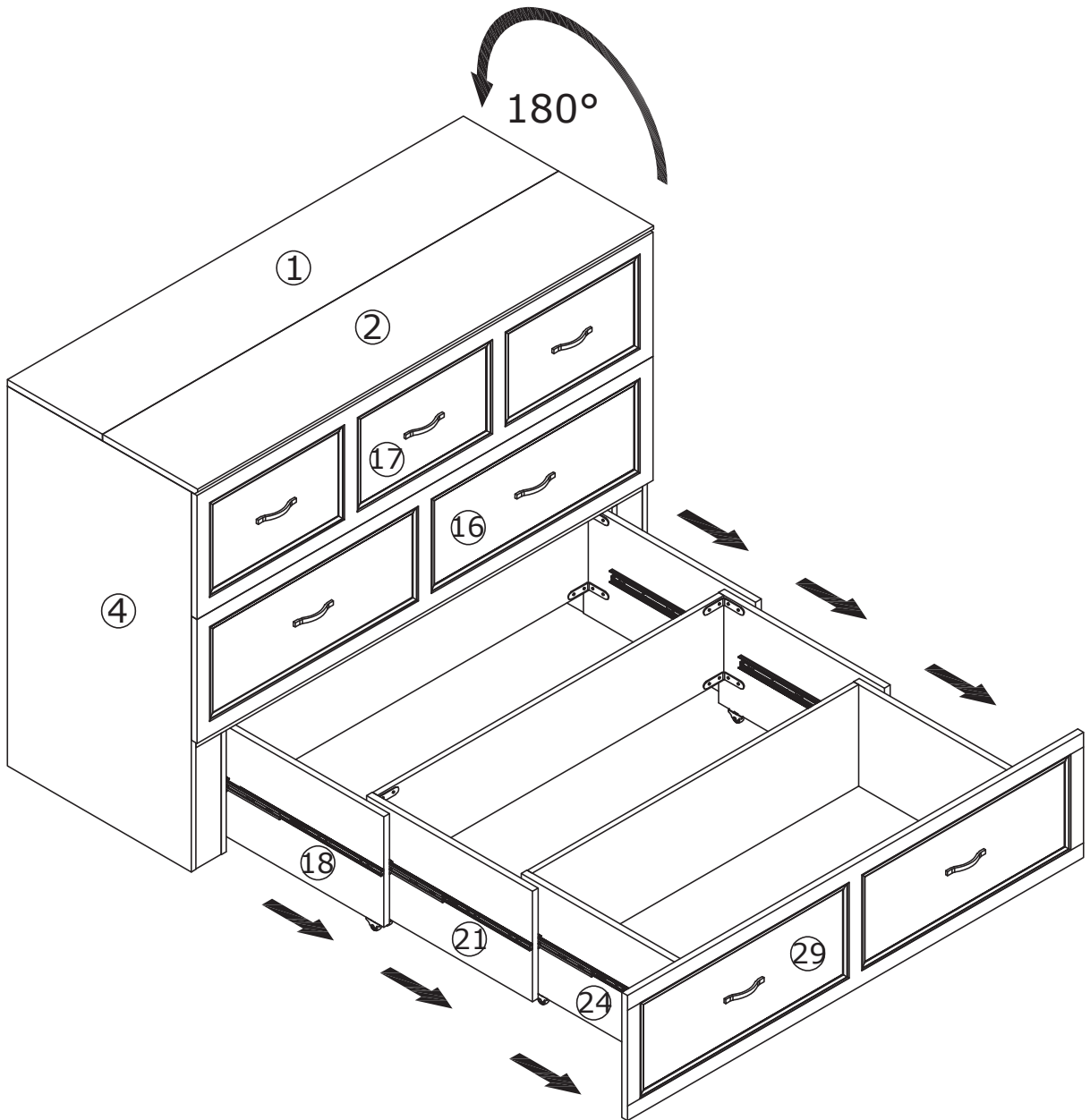
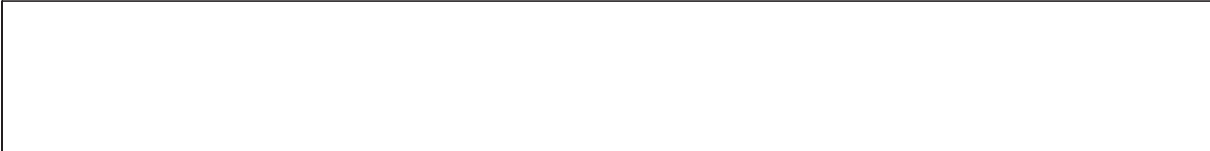

60

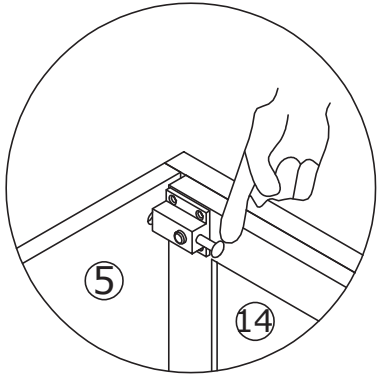
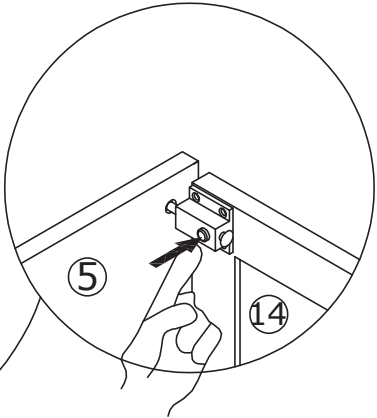
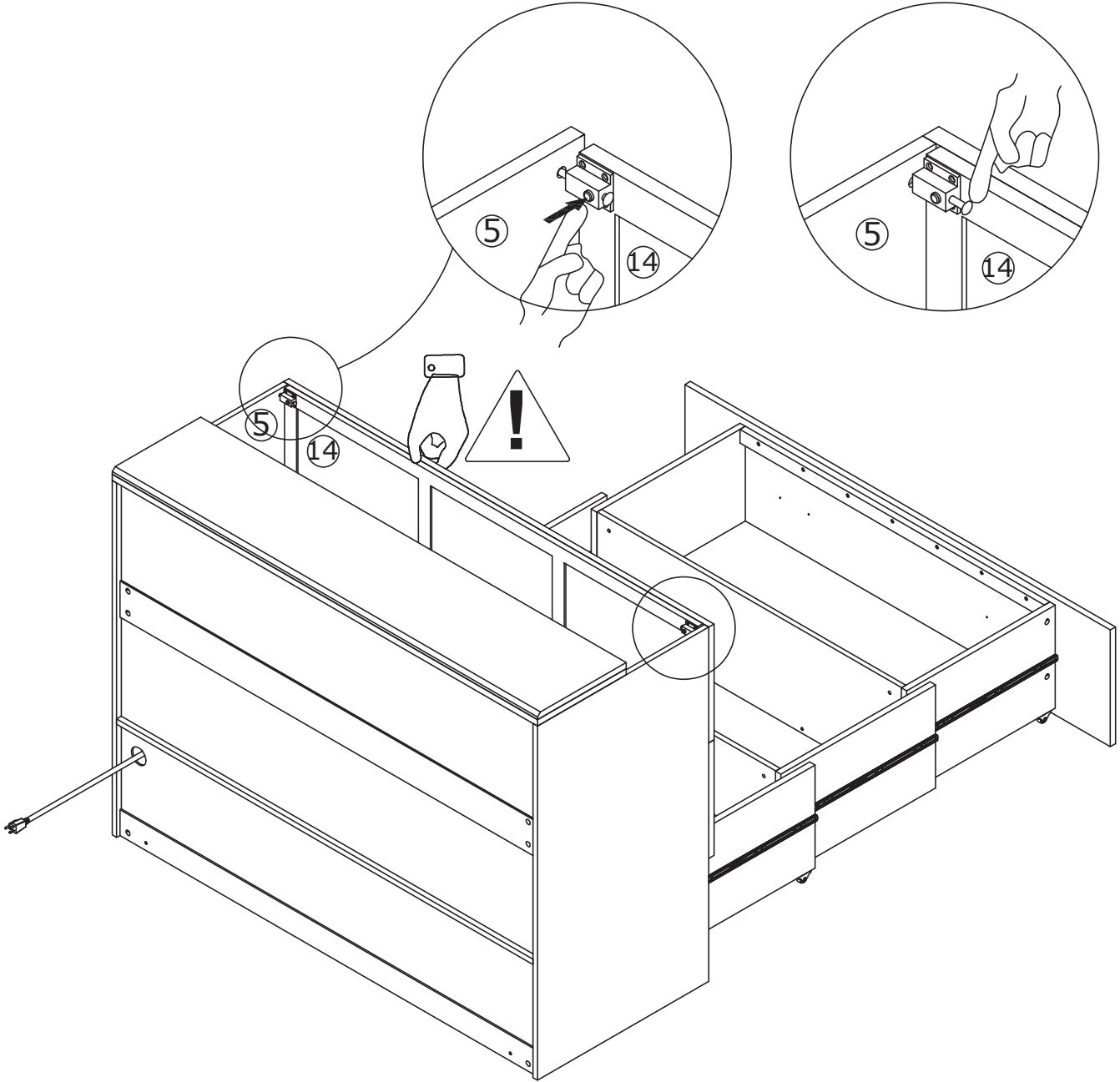
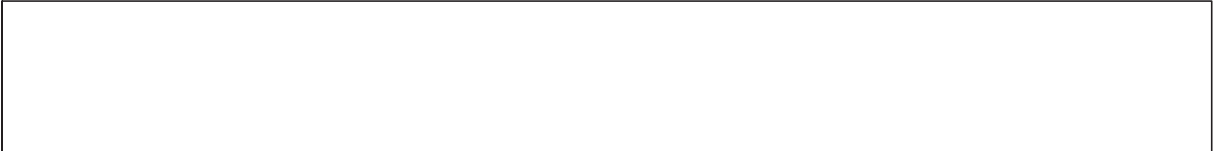

61

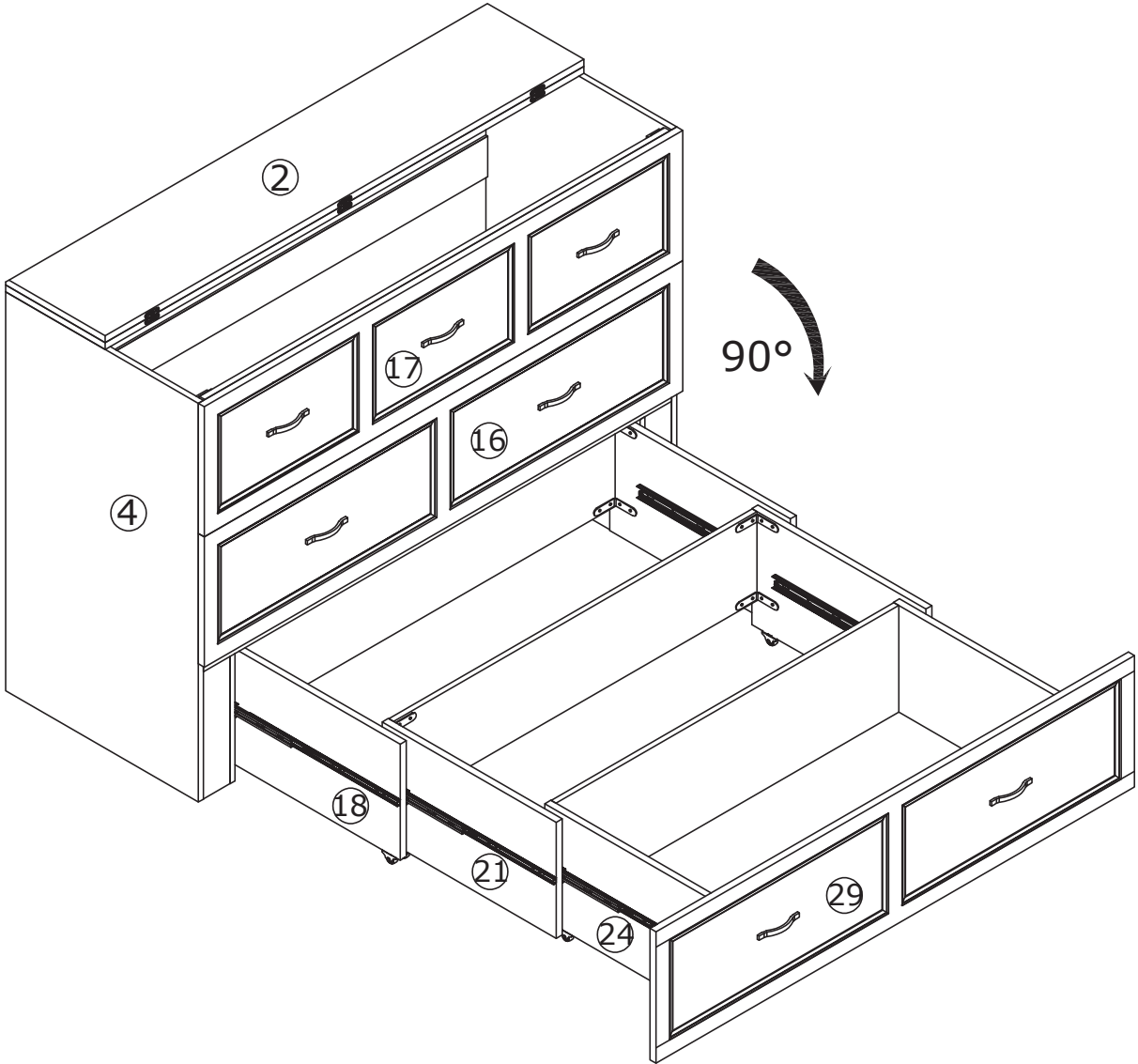
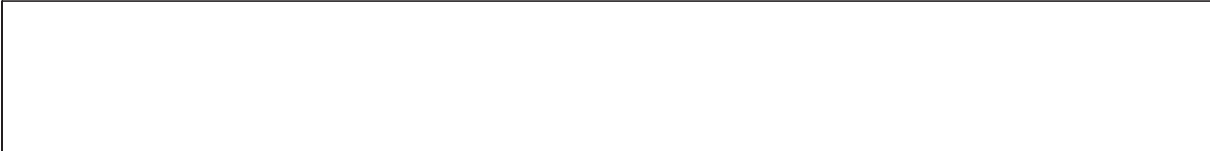

62

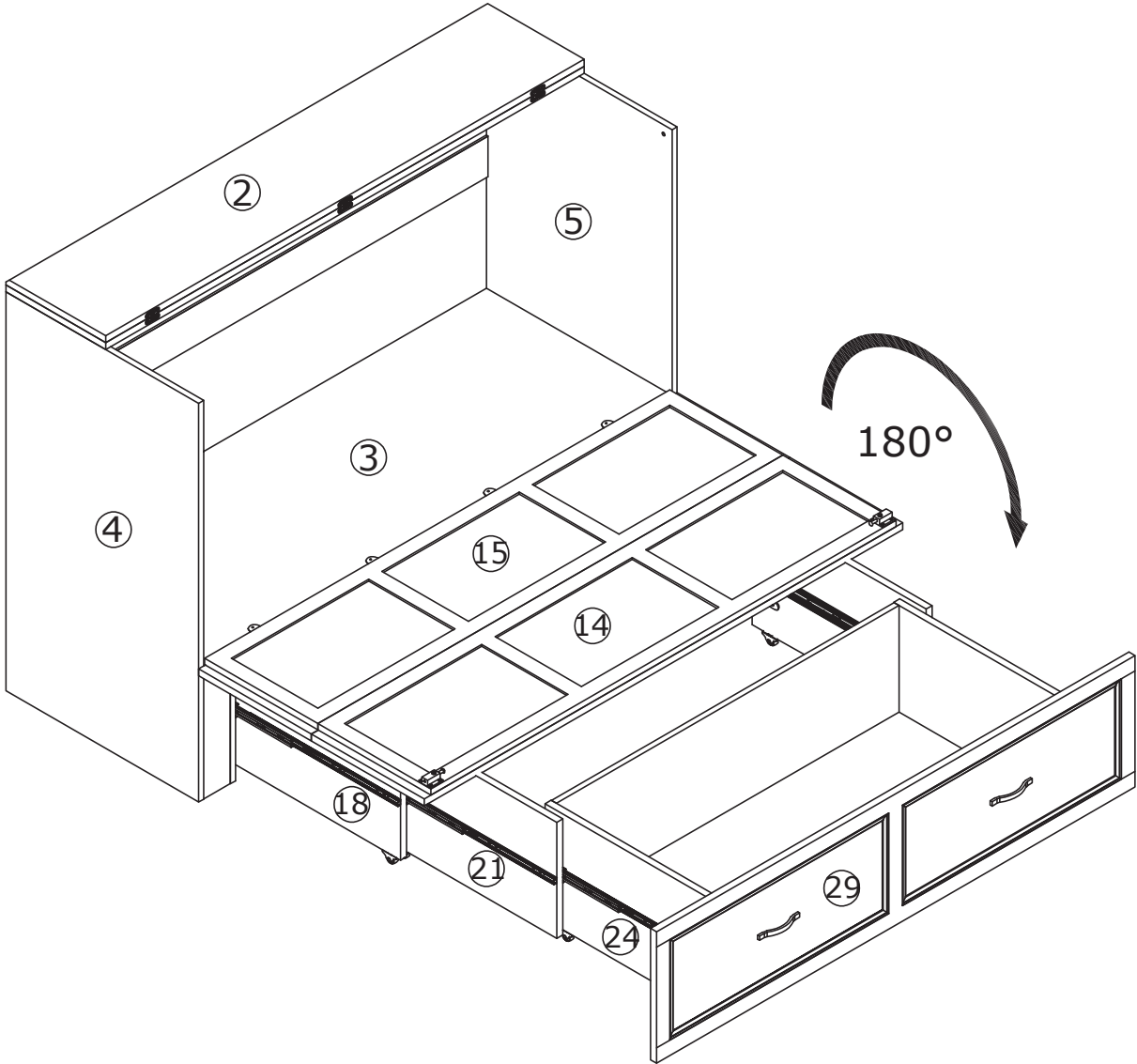
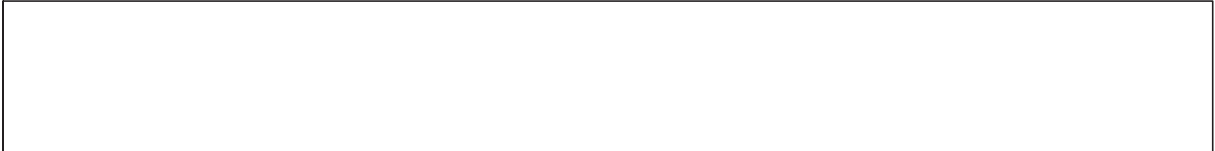

63

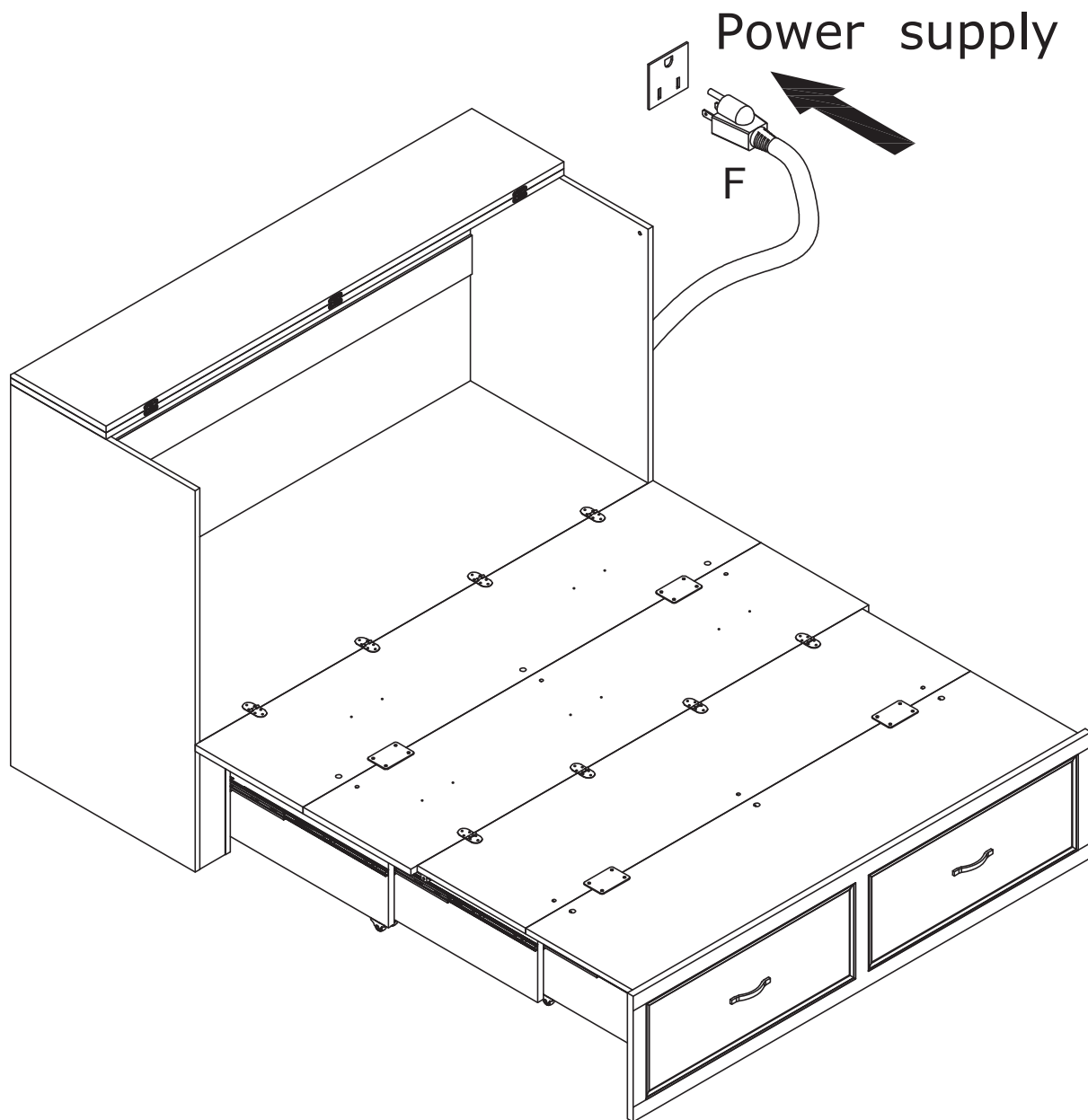

WARRANTY

WARRANTY CLAIMS

- There is a 30-day warranty for broken furniture or any other problems that do not work properly. The warranty will start from the date of purchase which must be verified by proof of purchase.
- Before making a claim, we may be able to answer your query, simply call us. Please leave your purchase order number, along with some details of the problem, if you want a replacement part. We will arrange within 48 hours. If there is out of stock, we will reply with a shipping date.
- The product must be used in accordance with the instructions provided. For health reasons.
- For other reasons, if the furniture needs to be returned, it must be cleaned and dried and operated within 30 days of receipt.

Type of Warranty Claim

- Failure to follow the furniture instructions will invalidate the warranty. Attention please.
- Does not include damage during installation, but includes damage during transportation.

Scope of responsibility

- Shall not bear any responsibility for misuse or user damage and / or loss of parts during the installation of furniture.
- After using, the damage and scratches of the furniture are not covered by the warranty.

The Warranty Relates to All Bought in The Us and Covers The Following Areas

- Sheet parts: 1 month from the date of purchase.
- Electrical parts: 1 month from the date of purchase.

RETURNS

CHANGED YOUR MIND AND NEED TO RETURN YOU ITEM?

PLEASE FOLLOW THE BELOW INSTRUCTIONS:

- If you have purchased and have simply changed your mind, follow the retailer's instructions for returns.

DEFECTIVE ITEMS

- If your item is defective in any way, i.e. it doesn't work but you can't identify why, in the first instance, please call us.

DAMAGED ITEMS

- If you receive an order with obvious shipping damage from the retailer, then we suggest the delivery is refused. If the delivery has been accepted and then shipping damage is found, please follow the specific instructions advised by the retailer. In all circumstances please save all packaging material and paperwork for the order. Please be aware that if you dispose of packaging material or attempt to return the merchandise without contacting the fulfiller, you jeopardise your chances of making a claim, and you may not receive a credit for the return.