

Contact Us: **FACTORY UTV LLC.**

9237 Beatty Drive Sacramento, CA 95826

Phone : (916) 383-2730

E-mail : info@factoryutv.net

Go online: www.Factoryutv.net



U.H.M.W. Skid Plate / Under Armor Package

Ultra. High. Molecular. Weight. polyethylene all terrain skid plate / under armor kit for UTV's

Installation Guide (Skid Plate & Rock Sliders)

Polaris *Xpedition-5 (2024+)*



Polaris Xpedition-5 (2024+) Instructions

#1 **Remove stock skid:** Remove (3x) T-40 Torx bolts from each plastic side panel to help remove skid. Remove stock skid plate and keep all hardware for later use. Once removed re-install T-40 Torx bolts on each side panel.

#2 **Cut stock skid plate.**
Cut the stock skid plate with a jig saw where marked to remove the Quarter Guards.



Re-install each Quarter Guard with the stock forward (2x) T-40 Torx bolts. Leaving the countersunk mounting holes empty for now.



#3 **Install Extension bracket.**

Use: (4x) stock bolts without washers, to hold extension brackets in (A) locations during skid plate install. Ensure extension bracket arrow points toward the front. Mount with J-clips Tip's facing inward toward vehicle. Remove and Re-install bolts with washers during skid plate installation.



#4 **Install Side Spacers.**

Install spacers along the length of the outer frame rails. Insure that the pointed end faces the rear. (Install 1/2" spacer with cutouts facing outward.)

Spacers are an interference fit, some force may be required. Spacer should sit flush with inner frame rail. (Refer to diagram on page 3)



#5 **Install Skid Plates.**

Starting with the rear skid working forward. Install bolts with washers loosely for adjustment. Thread locking compound is recommended.

Install: (3x) Stock Bolts in *Rear Diff Skid*: (A) locations & (4x) 1/4"-20 x 3/4" Self Tapping Bolts in (B) locations.

Install: (10x) Stock Bolts in *Mid Rear Skid*: (A) locations; (1x) 1/4"-20 x 3/4" Self Tapping Bolts in (B) locations; & (3x) M6-1.0 x 20mm Flange Bolts in (C) locations.

Install: (6x) Stock Bolts in *Main Skid*: (A) locations; (3x) M6-1.0 x 20mm Flange Bolts in (C) locations; & (4x) M6-1.0 x 30mm Flange Bolts in (D) locations.

If Rock Sliders replace (2x) M6-1.0 x 40mm Flange Bolts in (D*) locations.

Align *Front Diff* edge with *Main Skid*. Drill, Tap, & Install: (6x) 1/4"-20 x 1/2" Self Tapping Bolts in *Front Diff Skid*: (E) locations.

***RS**

Side Bolts / Rock Sliders: Drill, Tap, & Install: (16x) 1/4"-20 x 1 1/2" Self Tapping Bolts in *Side Bolts*: (F) locations.

If *Rock Sliders* are to be installed replace (F*) locations with (16x) 1/4"-20 x 2" Self Tapping Bolts. Slide *Rock Sliders* in-between *Skid Plate* & body plastic.

Polaris Xpedition-5 (2024+)

*** Drilling Instructions : ***

Use a : #N_o7 (13/64th) drill bit,

(one size above the commonly available 3/16th bit) Recommended
1/4" - 20 Tap * (Optional)

To drill and thread self tapping bolts in to chassis frame.

Finger Thread All Bolts Prior To Fastening Securely With Power Tools.



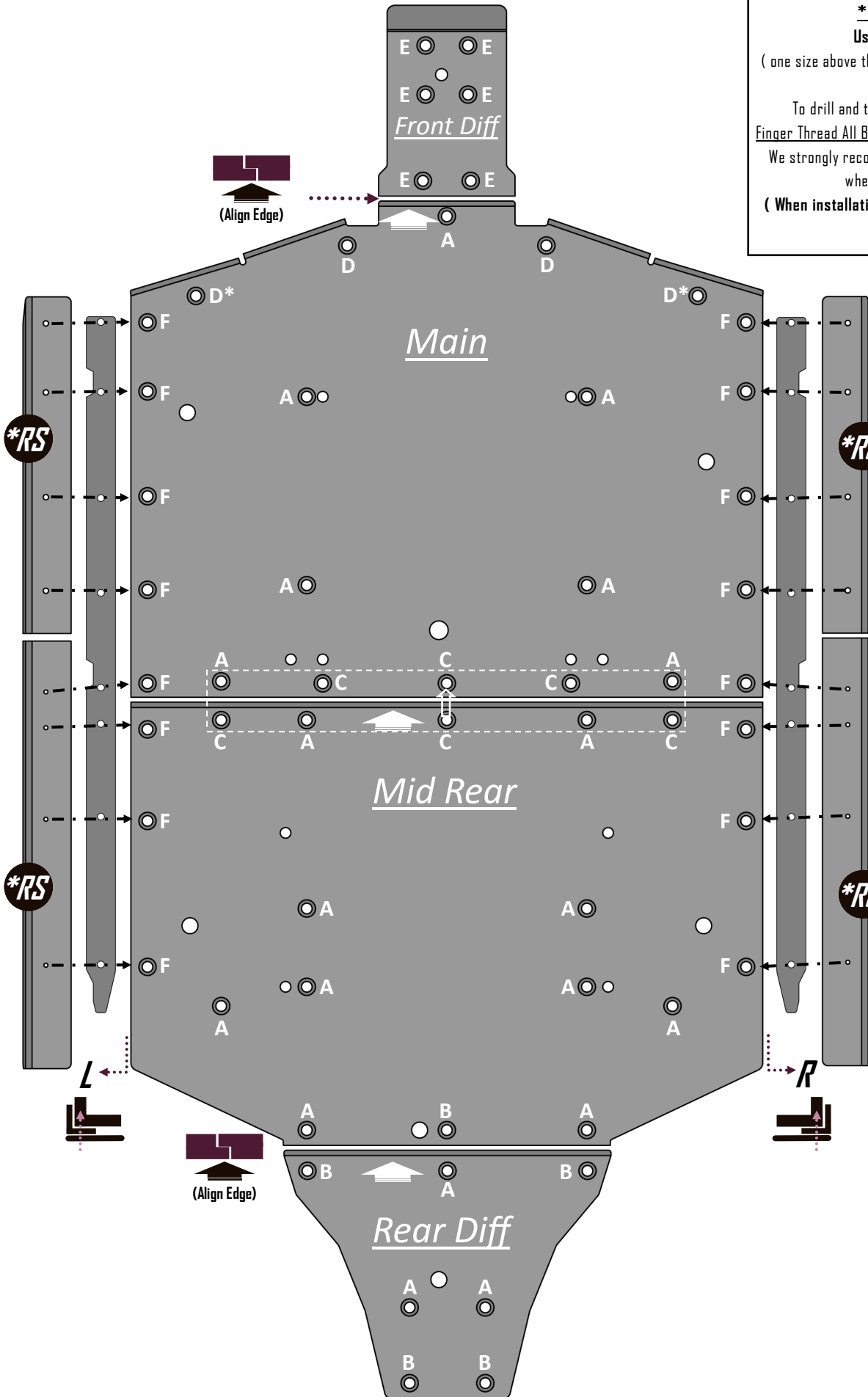
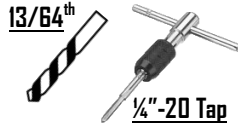

We strongly recommend the use of a "Thread Locking Compound"
when installing any mounting hardware.

(When installation is complete , ensure all bolts are fastened
securely.)



***If Rock Sliders**
Install Rock Sliders between
skid plate & chassis frame.



Main Skid Small bag:

-  ----- **6x**
M6- 1.0 x 20mm Flange Bolt (#B-A:5)
-  ----- **4x**
M6- 1.0 x 30mm Flange Bolt (#B-A:7)
-  ----- **7x**
Counter Sunk Washers (#W-1)
-  ----- **1x**
1/4"-20 x 3/4" Self Taping Bolt (#B-D:2)
- RS**  ----- **2x**
If : Rock Slider 's replace >
M6- 1.0 x 40mm Flange Bolt (#B-A:9)

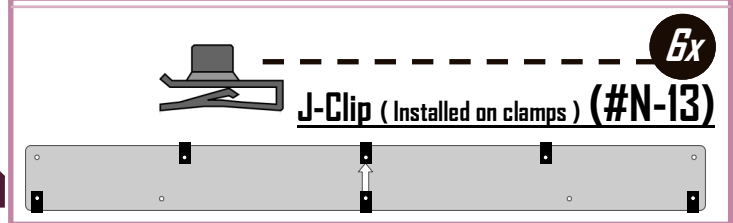

Cross Member Bracket:





Side Bolts Large bag:

-  ----- **16x**
1/4"-20 x 1 1/2" Self Taping Bolt (#B-D:6)
-  ----- **15x**
Counter Sunk Washers (#W-1)
- RS**  ----- **15x**
If : Rock Slider 's replace
- 1/4"-20 x 2" Self Taping Bolt (#B-D:7)

Front Diff Skid Small bag:

-  ----- **6x**
1/4"-20 x 1/2" Self Taping Bolt (#B-D:5)
-  ----- **6x**
Counter Sunk Washers (#W-1)

Rear Diff Skid Small bag:

-  ----- **4x**
1/4"-20 x 3/4" Self Taping Bolt (#B-D:2)
-  ----- **4x**
Counter Sunk Washers (#W-1)