

Contact Us: *FACTORY UTV LLC.*

9237 Beatty Drive Sacramento, CA 95826

Phone : (916) 383-2730

E-mail : info@factoryutv.net

Go online: www.Factoryutv.net



U.H.M.W. Skid Plate / Under Armor Package

Ultra. High. Molecular. Weight. polyethylene all terrain skid plate / under armor kit for UTV's

Installation Guide (Skid Plate)

Speed UTV "Baja Bandit"



Speed UTV "Baja Bandit" Instructions

- #1** Remove all stock skid plates. Re-install the 2 forward stock countersunk bolts that hold the metal bash plate to the front differential. Discard all other stock hardware.
- #2** Install *REAR DIFF* skid using (6x) M6-1.0 x 20mm Flange Bolts and washers in (A) locations. Leave bolts loose to allow for adjustment. *If installing *X-BRACE* : Hang *X-BRACE* with (4x) M6-1.0 x 20mm Flange Bolts in center (A) locations, then install *REAR DIFF* over the *X-BRACE* and reinstall washers in (4x) center (A) locations.
- #3** Install *MID REAR* skid using (8x) M6-1.0 x 20mm Flange Bolts and washers in (A) locations. Leave bolts loose to allow for adjustment.
- #4** Install *MAIN* skid using (10x) M6-1.0 x 20mm Flange Bolts and washers in (A) locations. Leave bolts loose to allow for adjustment.
- #5** Center skid plate edges and align overlaps, Tighten all (A) locations. Mark, Drill, and Tap all of the remaining (C) locations with (9x) $\frac{1}{4}$ "-20 x $\frac{3}{4}$ " Self Tapping Bolts and washers.
- #6** Install *FRONT DIFF* skid using (6x) M8 1.25x20mm Button Head Torx Bolts and washers in (B) locations. Align edge with *MAIN* skid and tighten bolts. Clamp front lip flush with bash plate and center mark (D) & (E) locations for drilling. Remove *FRONT DIFF* and Install (4x) $\frac{1}{4}$ "-20 x Nutserts in (D) & (E) locations. Fully install *FRONT DIFF* using (6x) M8 1.25x20mm Button Head Torx Bolts and washers in (B) locations; (2x) $\frac{1}{4}$ "-20 x $\frac{1}{2}$ " Flange Bolts and washers in (D) locations; & (2x) $\frac{1}{4}$ "-20 x 1" Counter Sunk Bolts in (E) locations.
Note: $\frac{1}{4}$ "-20 Nutserts require a 25/64" drill bit

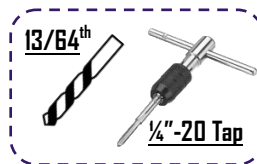
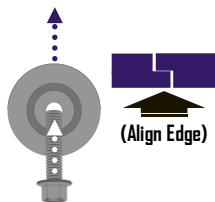

*** Drilling Instructions : ***

Use a : #No7 (13/64th) drill bit,

(one size above the commonly available 3/16th bit) Recommended $\frac{1}{4}$ "- 20 Tap *(Optional)

To drill and thread self tapping bolts in to chassis frame.

Finger Thread All Bolts Prior To Fastening Securely With Power Tools.

We strongly recommend the use of a "Thread Locking Compound" when installing any mounting hardware.

(When installation is complete , ensure all bolts are fastened securely.)

Speed UTV "Baja Bandit" Instructions

Front Diff

#6

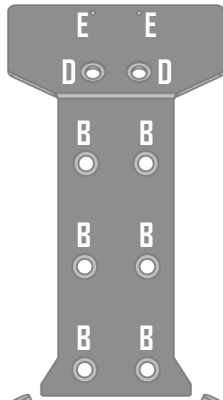

Before skid plate installation; Re-install the 2 forward stock countersunk bolts that hold the metal bash plate to the front differential.

* Drilling Instructions : *

Use a : #Nº7 (13/64th) drill bit, (one size above the commonly available 3/16th bit) Recommended ¼" - 20 Tap * (Optional)

To drill and thread self tapping bolts in to chassis frame.

Finger Thread All Bolts Prior To Fastening Securely With Power Tools.

We strongly recommend the use of a "Thread Locking Compound" when installing any mounting hardware.

(When installation is complete , ensure all bolts are fastened securely.)

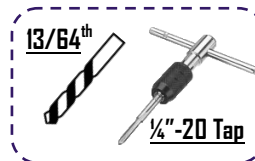

Main

#4

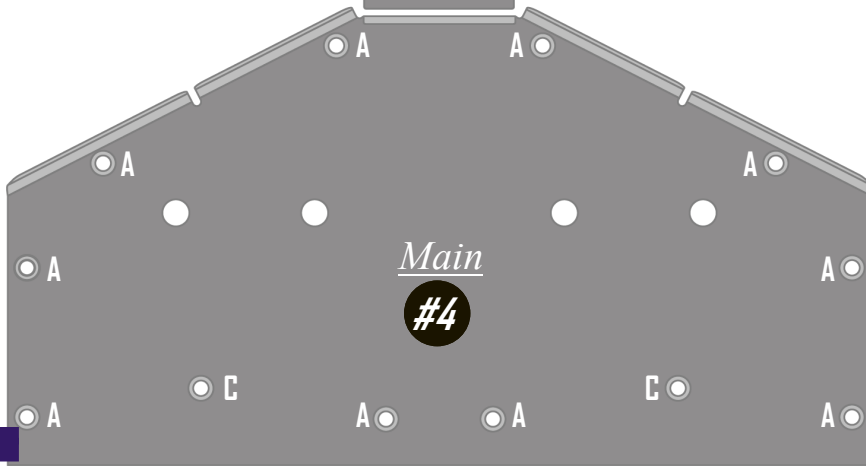

Mid Rear

#3

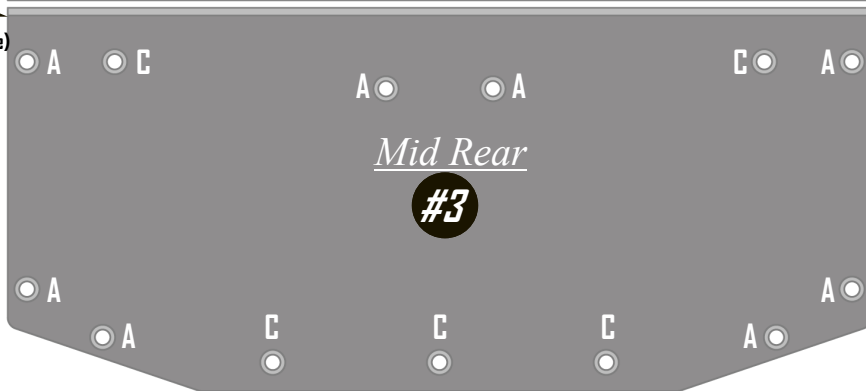

Rear Diff

#2

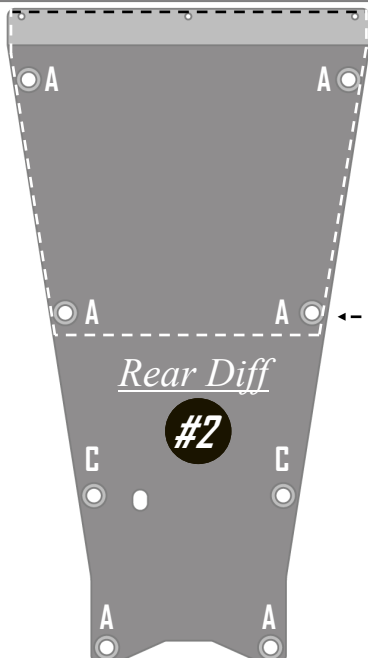

Optional X-Brace

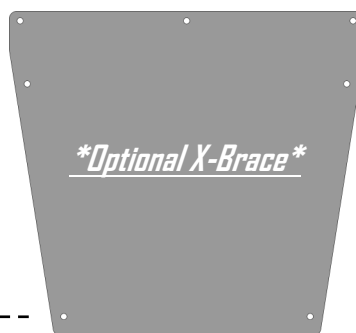

Aluminum X-Brace:

For extra protection Install optional X-brace in-between skid & chassis frame, Finger tighten bolts to allow for adjustment before fastening all bolts securely

Speed UTV "Baja Bandit" Hardware

Main Skids Large bag:

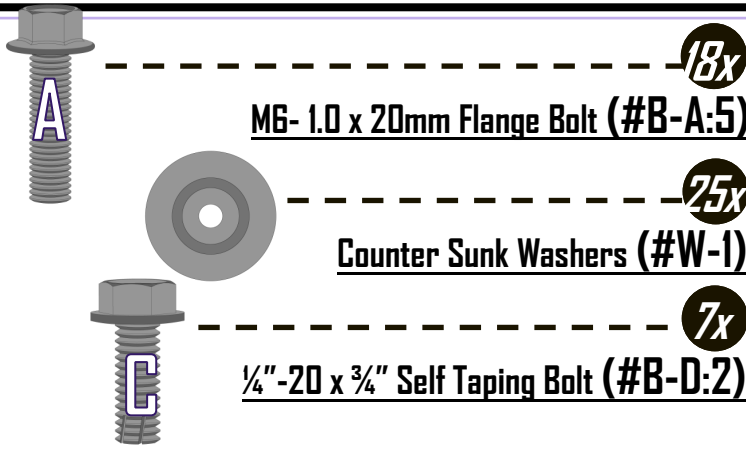

Rear Diff Skid Small bag:

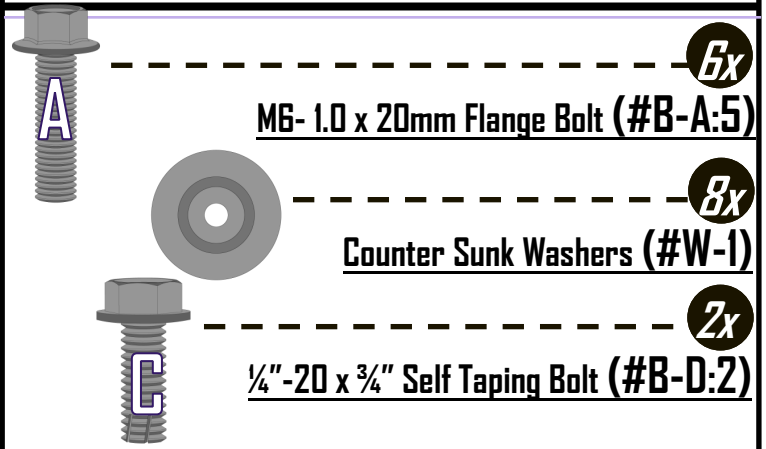

Front Diff Skid Small bag:

