

Contact Us: FACTORY UTV LLC

9237 Beatty Drive Sacramento, CA 95826

Phone : (916) 383-2730

E-mail : info@factoryutv.net

Go online: www.Factoryutv.net



U.H.M.W. Skid Plate / Under Armor Package

Ultra. High. Molecular. Weight. polyethylene all terrain skid plate / under armor kit for UTV's

Installation Guide

Can-Am Commander / Maverick Sport and Trail (2021+)

Fits:

2021+ Commander 1000R EFI, DPS, XT, XT-P

2020 - 2021+ Maverick Sport 1000R EFI, DPS, XT, XT-P

2021+ Maverick Trail, 800, 1000



Can-Am Commander / Maverick Sport and Trail (2021+)

UHMW Ultimate Package Installation

#1

Remove Stock Skid Plate :

Remove (8x)  M6 x 20 Torx Bolts in quarter guards, and (4x) M6 x 25mm Hex bolts in rear side panel: (D) locations. Carefully Drill Out ALL Rivet Locations. Use caution while drilling, you will re-use mounting holes with self tapping bolts. You may need to use a hammer to push in rivet ends. We recommend the use of a $\frac{1}{4}$ "- 20 Tap after drilling.

#2

Install Front Quarter Guard Brackets :

**($\frac{1}{4}$ "-20) Tap*



Install left and right Quarter Guard Brackets behind stock plastic Front Quarter Guards, with (4x) M6 x 20mm Counter Sunk Bolts in to bracket "J-Clip" (F) locations. Fasten until flush with plastic. Install: (2x) $\frac{1}{4}$ "-20 x 1" Self Tapping Bolts in: (A) locations, Install: (2x) $\frac{1}{4}$ "-20 x 1 $\frac{1}{4}$ " Self Tapping Bolts in: (B) locations. Fasten (A) and (B) bolts loosely on both Quarter Guard Brackets. (A + B bolts will be removed and re-installed with counter sunk washers in step #4.)

#3

Rear Skid Plate :

**If installing with X-Brace Plate, place X-Brace plate in-between rear skid plate and chassis frame, align holes while fastening.* Install: (12x) $\frac{1}{4}$ "-20 x 1" Self Tapping Bolts in Rear skid: (A) locations, the rear two (A) locations require a $\frac{1}{4}$ "- 20 Tap. Loosely mount bolts first, to aid positioning of skid plate on chassis frame, before fastening bolts securely. (Ensure to re-install (2x)  M6x20 Torx Bolts in rear passenger quarter guard.) —(Disregard (2x) side (D) locations until step #6)

#4

Main Skid Plate :

Install: (10x) $\frac{1}{4}$ "-20 x 1" Self Tapping Bolts in Main Skid: (A) locations, **Align edge with rear skid.*

Install: (4x) $\frac{1}{4}$ "-20 x 1 $\frac{1}{4}$ " Self Tapping Bolts in Main Skid: (B) locations.



Quarter Guard Brackets: Remove and replace (A) and (B) Bolts one at a time, Replace with (4x) counter sunk washers. Loosely mount bolts first, to aid positioning of main skid plate and rear skid plate on chassis frame before fastening securely.

#5

Front Diff. Skid Plate :

Nutsert tool NOT included

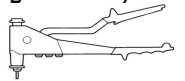

**Align edge with Main Skid. - Use of a Nutsert tool is required for installation.*

Install: (4x) $\frac{1}{4}$ "- 20 Nutsert's in Front Diff. Skid Plate: (E) locations. Ensure Nutsert's are fastened and crimped Securely.

Thread Nutsert on to tool, insert into (E) locations, crimp even and securely in place. If Nutsert spins, repeat crimping steps until snug fit.

Use: (4x) $\frac{1}{4}$ "-20 x $\frac{3}{4}$ " Flange Bolts With Nutsert's in: (E) locations.

Install: (2x) $\frac{1}{4}$ "-20 x 1" Self Tapping Bolts in Front Diff. Skid Plate: (A) locations.

Fasten bolts loosely, adjust diff skid plate to fit and align with main skid plate, fasten all bolts securely.

#6 *RS

Side bolts and/or Rock Sliders :

**If installing skid plate With Out Rock Sliders, use these bolts to fasten remaining side skid (A) and (D) locations.*

Install: (8x) $\frac{1}{4}$ "-20 x 1" Self Tapping Bolts in side skid: (A*) locations,

Install: (4x) M6- 1.0 x 30mm Flange Bolt in side skid: (D*) locations.

*if installing with Rock Sliders,

Install Rocksliders in-between skid plate and chassis frame using side bolt locations.

Use side mounting locations with longer hardware, in lieu of side bolts. (Your package will come with the appropriate hardware.)

Use: (8x) $\frac{1}{4}$ "-20 x 1 $\frac{1}{4}$ " Self Tapping Bolts (A* bolts) in Main Skid: (A*) locations, (in lieu of 8x (A) bolts)

Use: (4x) M6- 1.0 x 40mm Flange Bolt (D* bolts) in Main Skid: (D*) locations, (in lieu of 4x (D) bolts)

We recommended using a $\frac{1}{4}$ "- 20 Tap To Help thread self tapping bolts in to chassis frame.

Finger Thread All Bolts Prior To Fastening Securely With Power Tools.

We strongly recommend the use of a "Thread Locking Compound" when installing any mounting hardware.

(When installation is complete , ensure all bolts are fastened securely.)

Can-Am Commander / Maverick Sport and Trail (2021+)

UHMW Ultimate Package Installation

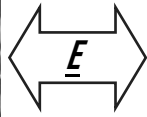
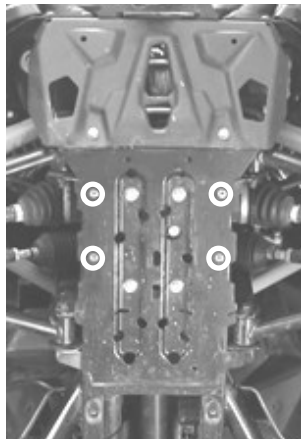

Use of Nutsert tool is required to crimp Nutserts to chassis frame.

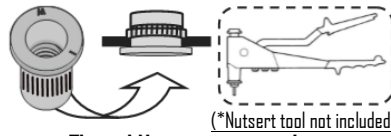

Thread Nutsert on to tool, insert into (E) locations, crimp even and securely in place. If Nutsert spins, repeat crimping steps until snug fit.

#1 Step 1:
See instructions on (Pg.2)
Remove stock skid plate,
*Drill out rivets as needed, &
Re-use mounting holes. Remove
8x Torx bolts in wheel well's.
Step 2: Mount front quarter panel brackets, install skid plates
Fasten bolts securely.

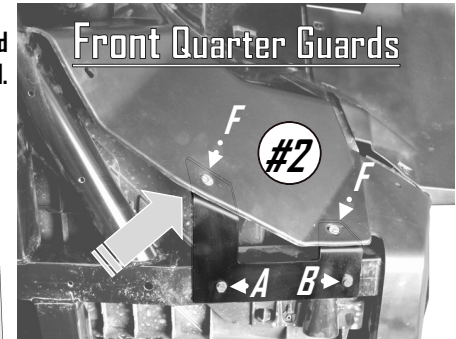

Front Quarter Guards

Front quarter guard brackets.
Mount front quarter guard plastic to front quarter guard brackets in (F) locations. Fasten bolts, until flush with plastic. Install lower bracket (A) & (B) bolts Loosely, without washers. (in step #4) back bolts out one at a time and Re-install bolts with counter sunk washers when fastening skid plates.

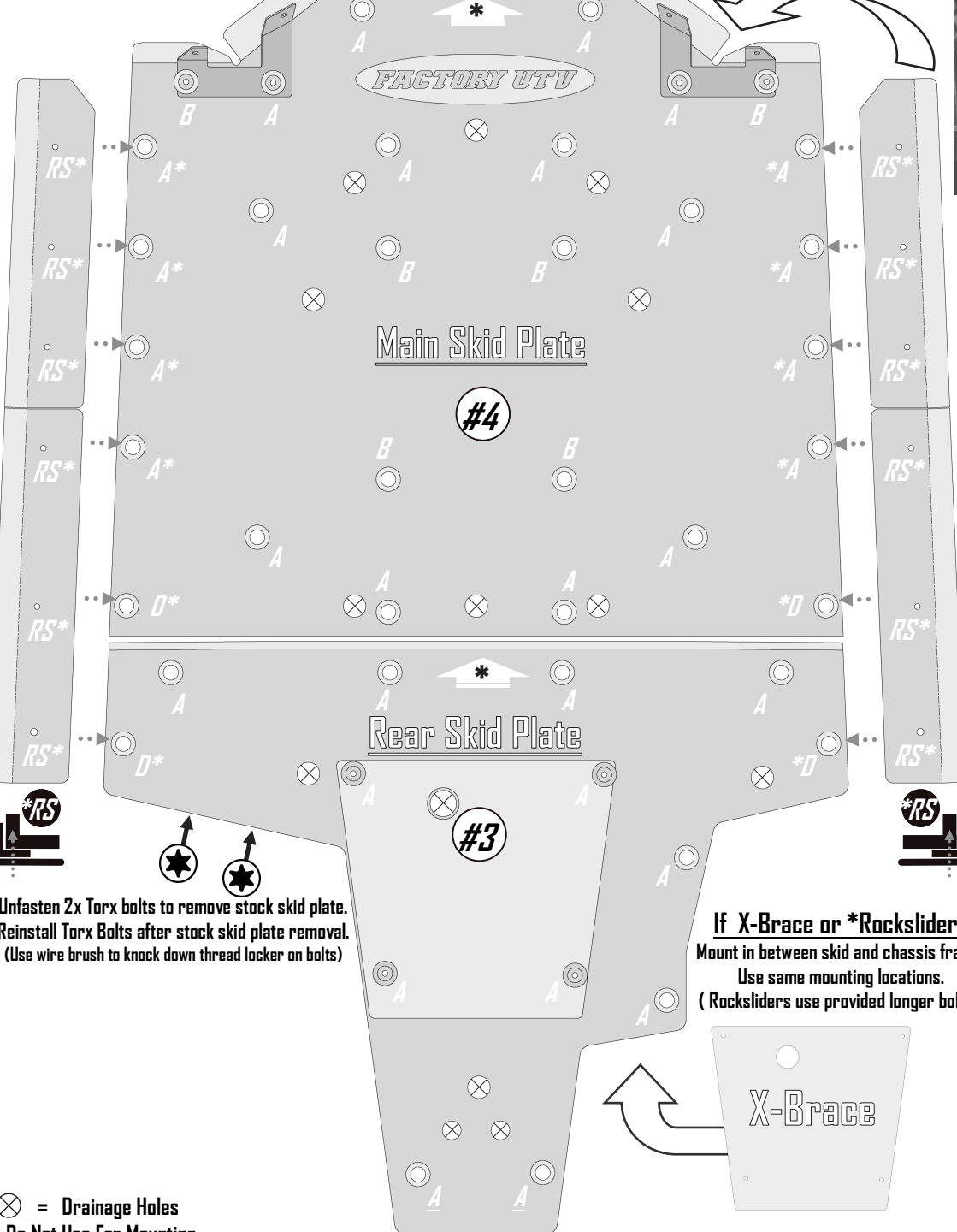
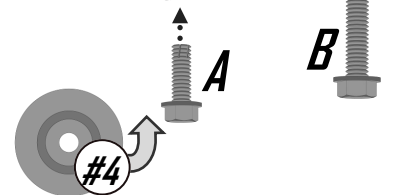
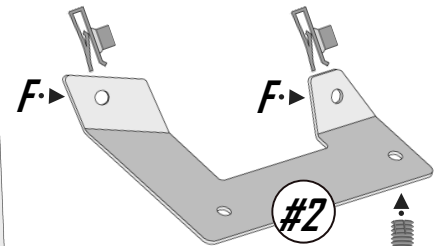
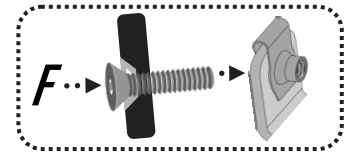

Remove Torx bolts attaching stock skid plate to front quarter guard.

Unfasten 2x Torx bolts to remove stock skid plate. Reinstall Torx Bolts after stock skid plate removal. (Use wire brush to knock down thread locker on bolts)

If X-Brace or *Rocksliders
Mount in between skid and chassis frame. Use same mounting locations. (Rocksliders use provided longer bolts)

Recommendations:

Use of (1/4"-20) Tap, and clamps





Installation may require the use of clamps or a car jack to aid holding skid plates during install.

= Drainage Holes
Do Not Use For Mounting

Can-Am Commander / Maverick Sport and Trail (2021+) Hardware

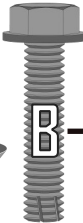
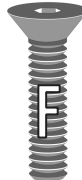
#2 Bracket bag:

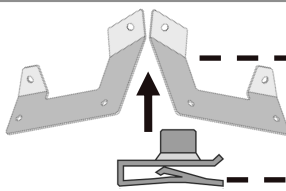

-  2x $\frac{1}{4}$ "-20 x 1" Self Tapping Bolt (#B-D:3)
-  2x $\frac{1}{4}$ "-20 x 1 $\frac{1}{4}$ " Self Tapping Bolt (#B-D:4)
-  4x M6- 1.0 x 20mm Counter Sunk Bolt (#B-C:10)

-  2x Left & Right Brackets (#E-B:20 & 21)
-  4x J-Clip (installed on brackets) (#N-13)



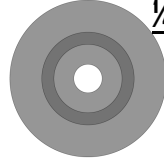

#3 Rear Skid small bag:

-  12x $\frac{1}{4}$ "-20 x 1" Self Tapping Bolt (#B-D:3)
-  12x Counter Sunk Washers (#W-1)

#4 Main Skid Large bag:

-  10x $\frac{1}{4}$ "-20 x 1" Self Tapping Bolt (#B-D:3)
-  4x $\frac{1}{4}$ "-20 x 1 $\frac{1}{4}$ " Self Tapping Bolt (#B-D:4)
-  18x Counter Sunk Washers (#W-1)
(+4 for step #4 quarter guard bracket locations)

#5 Front Diff Skid small bag:

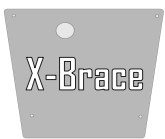

-  4x $\frac{1}{4}$ "-20 x Nutsert (#N-15)
-  4x $\frac{1}{4}$ "-20 x $\frac{3}{4}$ " Flange Bolt (#B-A:2)
-  2x $\frac{1}{4}$ "-20 x 1" Self Tapping Bolt (#B-D:3)
-  6x Counter Sunk Washers (#W-1)

(Optional)



-  1x Aluminum X-Brace Plate (#X-B:6)

**Use Rockslider Bag in lieu of side skid bag if installing Skid Plate with rocksliders, or standalone rocksliders*

#6 Sides Skid bag:

-  8x $\frac{1}{4}$ "-20 x 1" Self Tapping Bolt (#B-D:3)
-  4x M6- 1.0 x 30mm Flange Bolt (#B-A:7)
-  12x Counter Sunk Washers (#W-1)

***If Rock sliders bag:**

-  8x $\frac{1}{4}$ "-20 x 1 $\frac{1}{4}$ " Self Tapping Bolt (#B-D:4)
-  4x M6- 1.0 x 40mm Flange Bolt (#B-A:9)
-  12x Counter Sunk Washers (#W-1)

Your package will come with the appropriate side hardware based on your order, this area is for packaging and hardware reference.