

Contact Us: *FACTORY UTV LLC*

9237 Beatty Drive Sacramento, CA 95826

Phone : (916) 383-2730

E-mail : info@factoryutv.net

Go online: www.Factoryutv.net



U.H.M.W. Skid Plate / Under Armor Package

Ultra. High. Molecular. Weight. polyethylene all terrain skid plate / under armor kit for UTV's

Installation Guide (Ultimate Package)

Polaris

Ranger XP 1000 Crew (2018 - 2021+)



Polaris Ranger XP 1000 Crew (2018 - 2021+) instructions

#1

Remove: stock skid plate, re-use stock hardware as needed in all (A) locations.

Bend front Diff tab inwards with a mallet. (See: Chassis diagram pg.3)

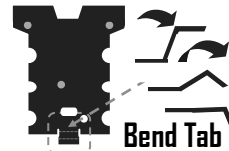

#2

Main and Mid Skid Plate :

Install Main Skid using: (6x) Stock Bolts & Washers (M6- 1.0 x 20mm Flange Bolts) *in Main Skid : (A) locations.*

(See Drilling Instructions Below) Mark, drill and install : (6x) $\frac{1}{4}$ "-20 x $\frac{3}{4}$ " Self Tapping Bolts, *in Main Skid : (B) locations.*

Install Mid Skid : Align edge with main skid. Install mid skid using : (8x) Stock Bolts & Washers, *in Mid Skid : (A) locations.*

Remove: (12x) T-40 Torx bolts on side panels. Install : (10x) M6- 1.0 x 20mm Flange Bolts along edge *in Main/Mid Skid : (C) locations.*

RS



If Rock Sliders :

Install Rock sliders in-between skid and chassis Frame. (Rock sliders use longer "RS" bolts, in lieu of (C and B) bolts, in side locations.)

Install: (10x) M6- 1.0 x 30mm Flange Bolts *in Main and Mid Skid / Rock slider : (C) locations.*

Install: (2x) $\frac{1}{4}$ "-20 x $1\frac{1}{4}$ " Self Taping Bolt *in Main Skid / Rock slider : (B) locations.*



#3

Rear Skid Plate :

(See Drilling Instructions Below) Align edge with Main Skid. Mark, drill and install: (6x) $\frac{1}{4}$ "-20 x $\frac{3}{4}$ " Self Tapping Bolts *in Rear Skid : (B) locations.*

*In the 2x rear most (B) locations, drill in to crease of metal, between hump and flat areas. (See chassis diagram pg.3)
(Mount forward bolts first, to aid positioning of rear skid and chassis frame before drilling.)*

#4

Front Diff. Skid Plate :

Bend front diff tab inwards (See: chassis diagram pg.3.) **(See Drilling Instructions Below)**

(2021+) — : Align edge and Mark the center of each hole. Using a 9/32nd Drill bit, Drill and

install: (4x) $\frac{1}{4}$ "-20 x $\frac{3}{4}$ " Flange Bolts with (4x) $\frac{1}{4}$ "-20 Flange Lock Nuts *in Front Diff. Skid : (B) locations.*

(2018 - 2020) - : Align edge, mark, drill and install: (4x) $\frac{1}{4}$ "-20 x $\frac{3}{4}$ " Self Tapping Bolts *in Front Diff. Skid : (B) locations.*

Rear A-Arm Guards :

Install : (4x) $\frac{1}{4}$ "-20 x $2\frac{1}{4}$ " Counter Sunk Bolts W/(4x) $\frac{1}{4}$ " Zinc Washers, and (4x) $\frac{1}{4}$ "x 20 Ny-Lock Nuts
in : (G) locations. (on Each Rear A-Arm Guard).

Front A-Arm Guards :

(2021+) — : Install : (4x) 1 x 1" "D" clamps over A-Arm tubing W/ (4x) $\frac{1}{4}$ "-20 x $1\frac{1}{4}$ " Counter Sunk Bolts, (4x) $\frac{1}{4}$ " Gold Washers, and (4x) $\frac{1}{4}$ "-20 Ny-Lock Nuts *in: all locations. (On Each A-Arm Guard)*



(2018 - 2020) — : Install : (3x) 1 x 1" "D" clamps over A-Arm tubing W/ (3x) $\frac{1}{4}$ "-20 x $1\frac{1}{4}$ " Counter Sunk Bolts, (3x) $\frac{1}{4}$ " Gold Washers, and (3x) $\frac{1}{4}$ "-20 Ny-Lock Nuts *in: (D*) locations.*

Install : (1x) $\frac{1}{4}$ "-20 x $1\frac{1}{2}$ " Counter Sunk Bolts, W/ (1x) $\frac{1}{4}$ " Gold Washers, and (1x) $\frac{1}{4}$ "-20 Ny-Lock Nuts through stock mounting holes *in: (E) locations. (On Each A-Arm Guard)*

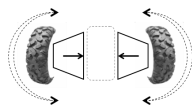

** Ensure Clearance For Turn Radius & Vertical Travel Before Fastening ALL Bolts Securely*

*** Drilling Instructions : ***

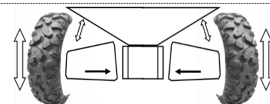

Use a : #N^o7 (13/64th) drill bit,

(one size above the commonly available 3/16th bit) Recommended $\frac{1}{4}$ "-20 Tap **(Optional)*

To drill and thread self tapping bolts in to chassis frame.

Finger Thread All Bolts Prior To Fastening Securely With Power Tools.

We strongly recommend the use of a "Thread Locking Compound" when installing any mounting hardware.

(When installation is complete , ensure all bolts are fastened securely.)

Polaris Ranger XP 1000 Crew (2018 - 2021+)

(2018 - 2020)

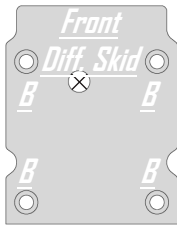

(2021+)

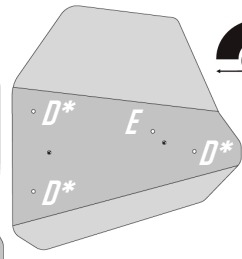
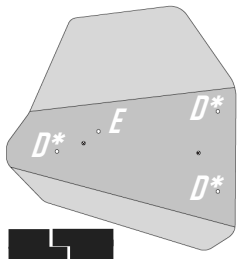
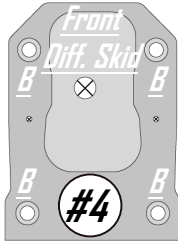

(2021+)

Front A-Arm Guards:
use same hardware
for all locations.

Read :
Instructions on pg.#2
Remove stock skid plate,
Reuse hardware as needed.
Skid plate will form to fit.
See drilling instructions
prior to drilling.

(Align Edge)

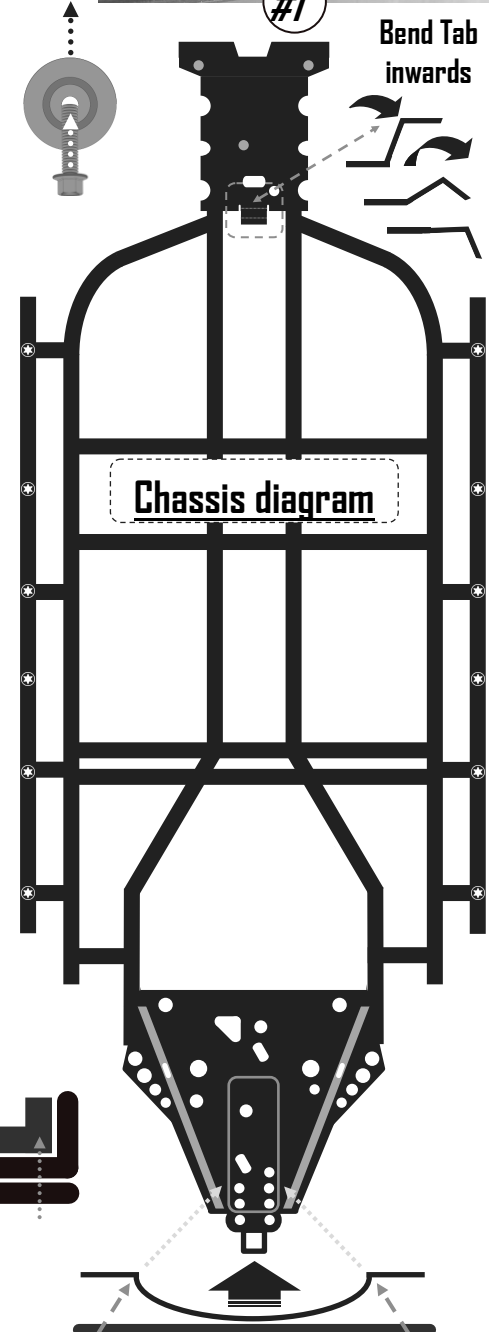
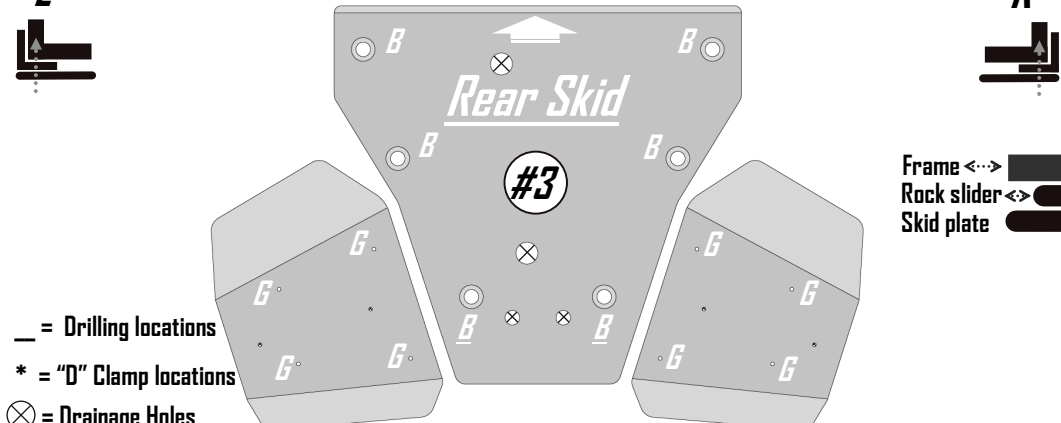
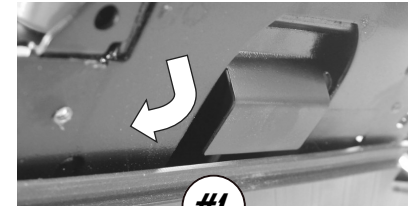

- _ = Drilling locations
- * = "D" Clamp locations
- ⊗ = Drainage Holes
- Do Not Use For Mounting

Drill in to crease for rear "B" locations

Polaris Ranger XP 1000 Crew

Hardware (2018 -2021+)

#2 Main skid Small Bag

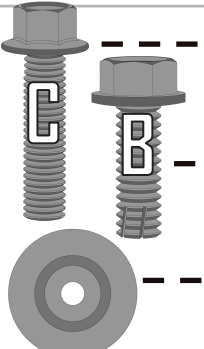

10x MG-1.0 x 20mm Flange Bolt (#B-A:5)

6x 1/4"-20 x 3/4" Self Taping Bolt (#B-D:2)

8x Counter Sunk Washers (#W-1)

***If Rock sliders Small Bag:**

* Use in lieu of 6 main skid C bolts

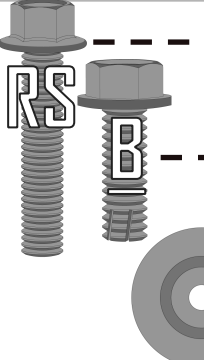

10x MG-1.0 x 30mm Flange Bolt (#B-A:7)

2x 1/4"-20 x 1 1/4" Self Taping Bolt (#B-D:4)

10x Counter Sunk Washers (#W-1)

Washers needed for standalone installation only.

#3 Rear skid Small Bag:

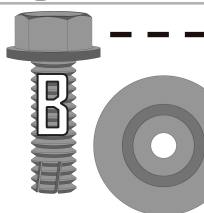

6x 1/4"-20 x 3/4" Self Taping Bolt (#B-D:2)

6x Counter Sunk Washers (#W-1)

#4 (2018 - 2020) Front Diff. Small Bag:

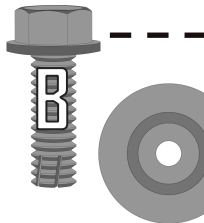

4x 1/4"-20 x 3/4" Self Taping Bolt (#B-D:2)

4x Counter Sunk Washers (#W-1)

#4 (2021+) Front Diff. Small Bag:

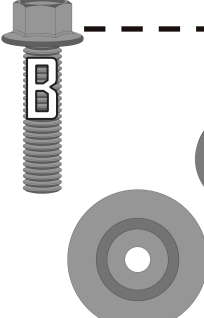

4x 1/4"-20 x 3/4" Flange Bolt (#B-A:2)

4x 1/4"-20 Flange Lock Nut (#N:3)

4x Counter Sunk Washers (#W-1)

F (2018 - 2020) Front A-Arms Small Bag:

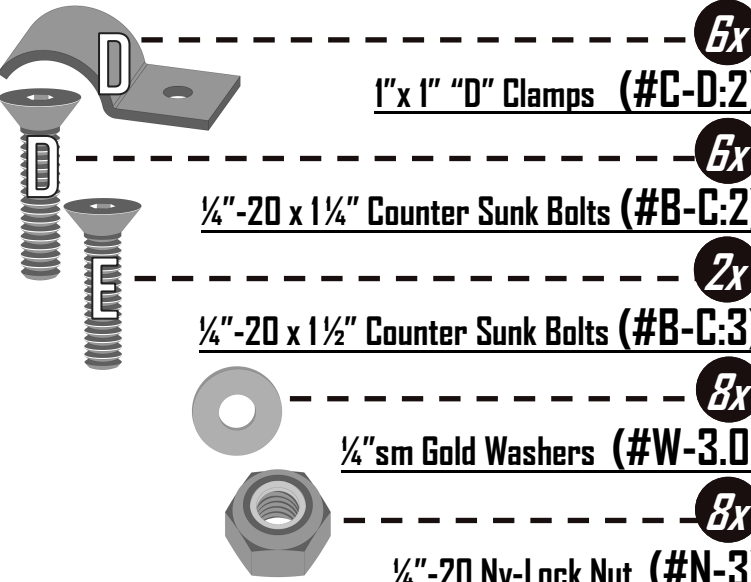

6x 1"x1" "D" Clamps (#C-D:2)

6x 1/4"-20 x 1 1/4" Counter Sunk Bolts (#B-C:2)

2x 1/4"-20 x 1 1/2" Counter Sunk Bolts (#B-C:3)

8x 1/4"sm Gold Washers (#W-3.0)

8x 1/4"-20 Ny-Lock Nut (#N-3)

F (2021+) Front A-Arms Small Bag:

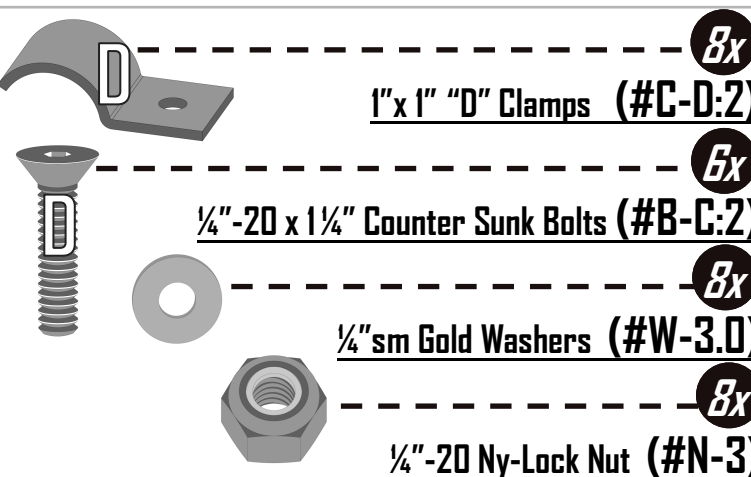

8x 1"x1" "D" Clamps (#C-D:2)

6x 1/4"-20 x 1 1/4" Counter Sunk Bolts (#B-C:2)

8x 1/4"sm Gold Washers (#W-3.0)

8x 1/4"-20 Ny-Lock Nut (#N-3)

R Rear A-Arms Small Bag:



8x 1/4"-20 x 2 1/4" Counter Sunk Bolts (#B-C:5)

8x 1/4"sm Silver Washers (#W-4.0)

8x 1/4"-20 Ny-Lock Nut (#N-3)