

Honda Talon 1000 (2019+)

Standalone Front Diff Skid Plate

Fits 2019+ : R, X, and 4 X models

Designed for use with Stock OEM skid plate

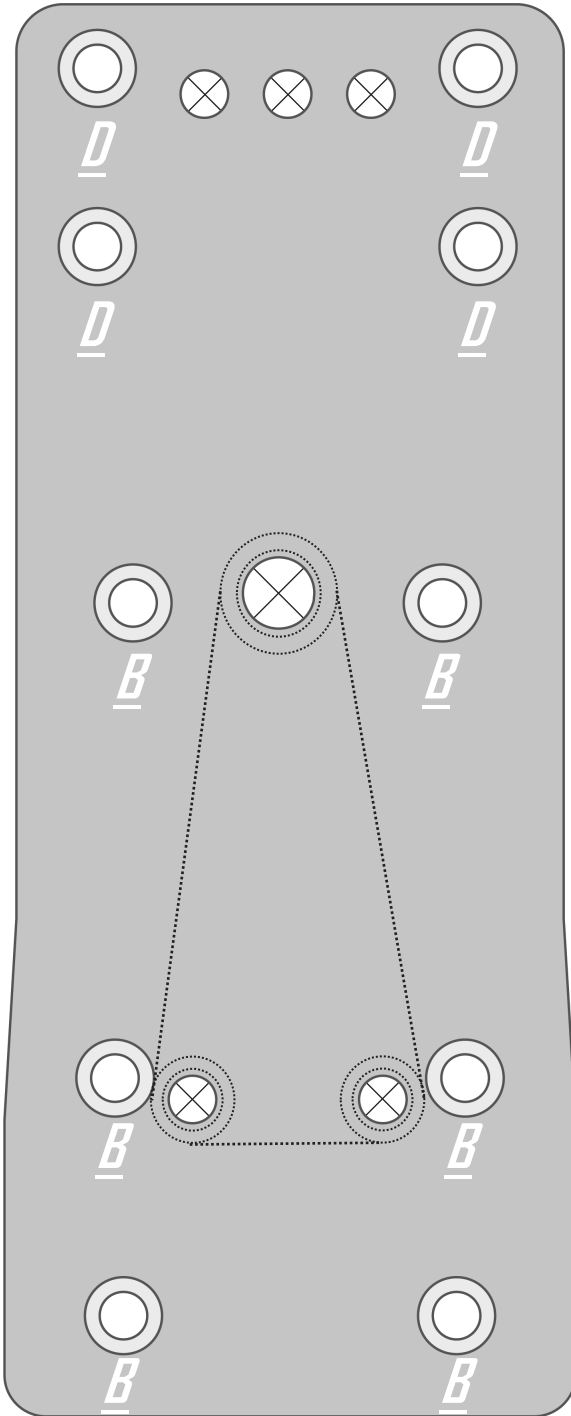

Recommended : 1/4"-20 Tap for (B) locations

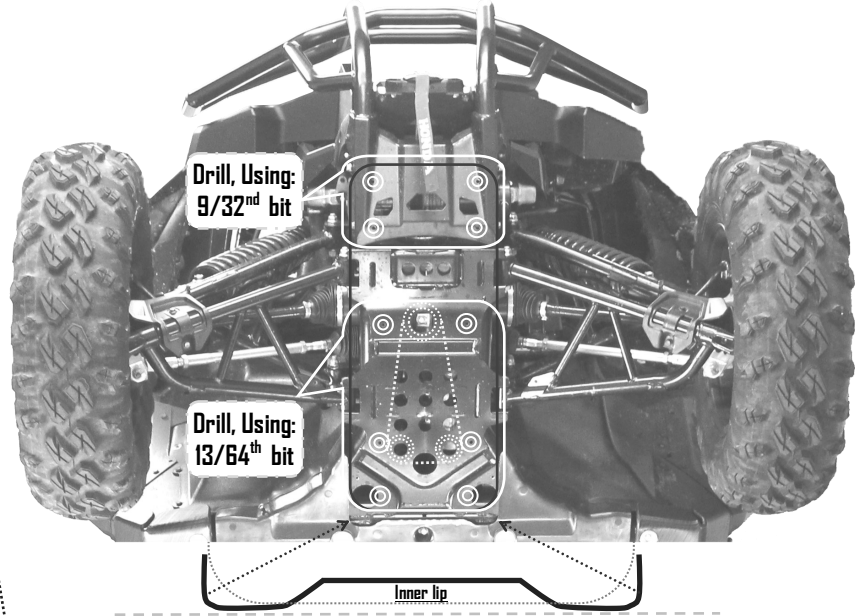

#1 Align bottom of standalone Front Diff Skid plate with the openings on both sides of stock slid plate, over lapping stock inner lip. (see diagram above).
Use (3x) Drain holes to triangulate, or help center the skid plate.
Mark Center of remaining mounting locations for drilling.

#2 For (B) locations: Drill 13/64th holes.
Install: (6x) 1/4"-20 x 3/4" Self Taping Bolts in: B locations

#3 For (D) locations: Drill 9/32nd holes,
Install: (4x) 1/4"-20 x 1" Flange Bolts in: D locations
With: (4x) 1/4"-20 Flange Nuts.
(*Use of clamps may aid in bending and installation of D locations)



#1 Standalone Front Diff Hardware	
	6x 1/4"-20 x 3/4" Self Taping Bolt (#B-D:2)
	4x 1/4"-20 x 1" Flange Bolt (#B-A:3)
	4x 1/4"-20 Flange Nut (#N-3)
	10x Counter Sunk Washers (#W-1)

Honda Talon 1000 X-R (2019+)

Go online to www.FactoryUTV.net and check out our other Talon products:

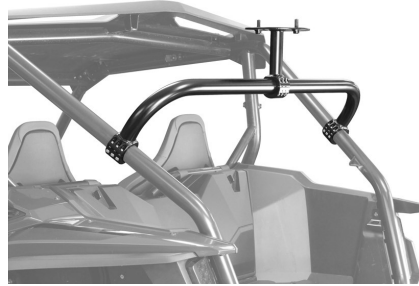

*Dual clamp
spare tire mount*

UHMW Rocksldiers



UHMW Skid Plate Packages

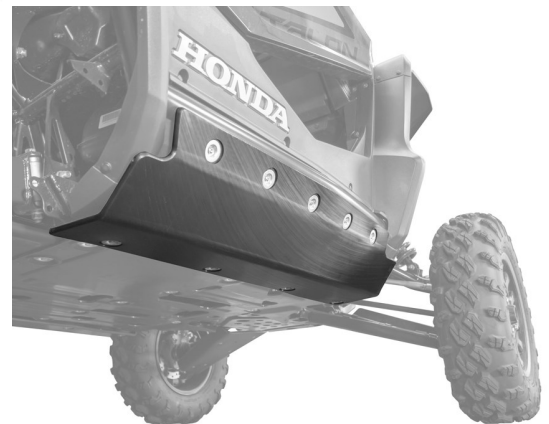
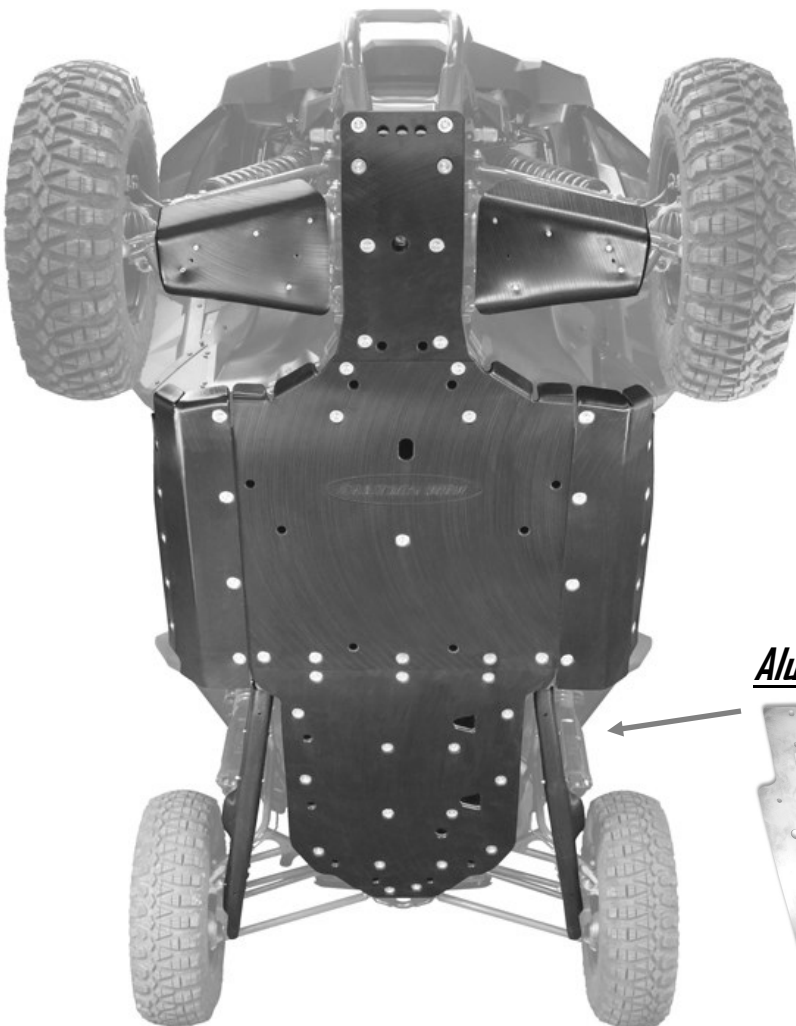

Aluminum X-Brace Plate

