

Contact Us: *FACTORY UTV LLC*

9237 Beatty Drive Sacramento, CA 95826

Phone : (916) 383-2730

E-mail : info@factoryutv.net

Go online: www.Factoryutv.net



U.H.M.W. Skid Plate / Under Armor Package

Ultra. High. Molecular. Weight. polyethylene all terrain skid plate / under armor kit for UTV's

Installation Guide (Ultimate Package)

Polaris

Ranger 800 Crew (2011-2014)



Polaris Ranger 800 Crew (2011-2014) instructions

Remove stock skid plate

#1

Main and Mid Skid Plate :

Install extension bracket with J-clip tips pointing up towards vehicle, using (A) bolts. During skid install, remove bolts individually and re-install bolts through skid plate with counter sunk washers.

Install using: stock bolts & washers in Main Skid: (A) locations,

Use provided M6- 1.0 x 20mm Flange Bolt (A) bolts as needed,

fasten loosely for installation adjustments. Install mid skid before main skid aligning edge.

#2

Rear Skid Plate :

Align edge with mid skid plate

Install (3x) M6- 1.0 x 20mm Flange Bolt (A) bolts, in (A) Locations

mark drill and install (2x) 1/4"-20 x 3/4" Self Tapping Bolt (B) bolts, in (B) Locations.

(See drilling instructions bellow)

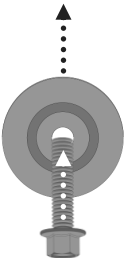

**(Align Edge)*

#3

Front Diff. Skid Plate :

Align edge with main skid plate, holding skid in place, mark and drill (C) locations,

Using a 25/64th drill bit, carefully drill and check fitment for nutserts.

Use nutsert tool to fasten and crimp nutsert securely.

Install 4x (C) bolts in (C) locations

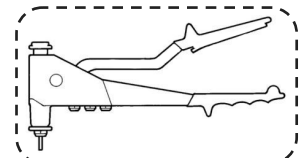

Use 1/4"-20 Nutsert tool

** Ensure Clearance For Turn Radius & Travel*

Before Fastening ALL Bolts Securely

Do Not Over Tighten Bolts

* Drilling Instructions : *

Use a : #No7 (13/64th) drill bit,

*(one size above the commonly available 3/16th bit) Recommended 1/4"- 20 Tap *(Optional)*

To drill and thread self tapping bolts in to chassis frame.

Finger Thread All Bolts Prior To Fastening Securely With Power Tools.

We strongly recommend the use of a "Thread Locking Compound" when installing any mounting hardware.

(When installation is complete , ensure all bolts are fastened securely.)

Polaris Ranger 800 Crew (2011-2014)

Read :
 Instructions on pg.#2
 Remove stock skid plate.
 Install extension bracket.
 See drilling instructions
 prior to drilling,
 Fasten securely.

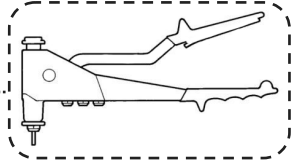
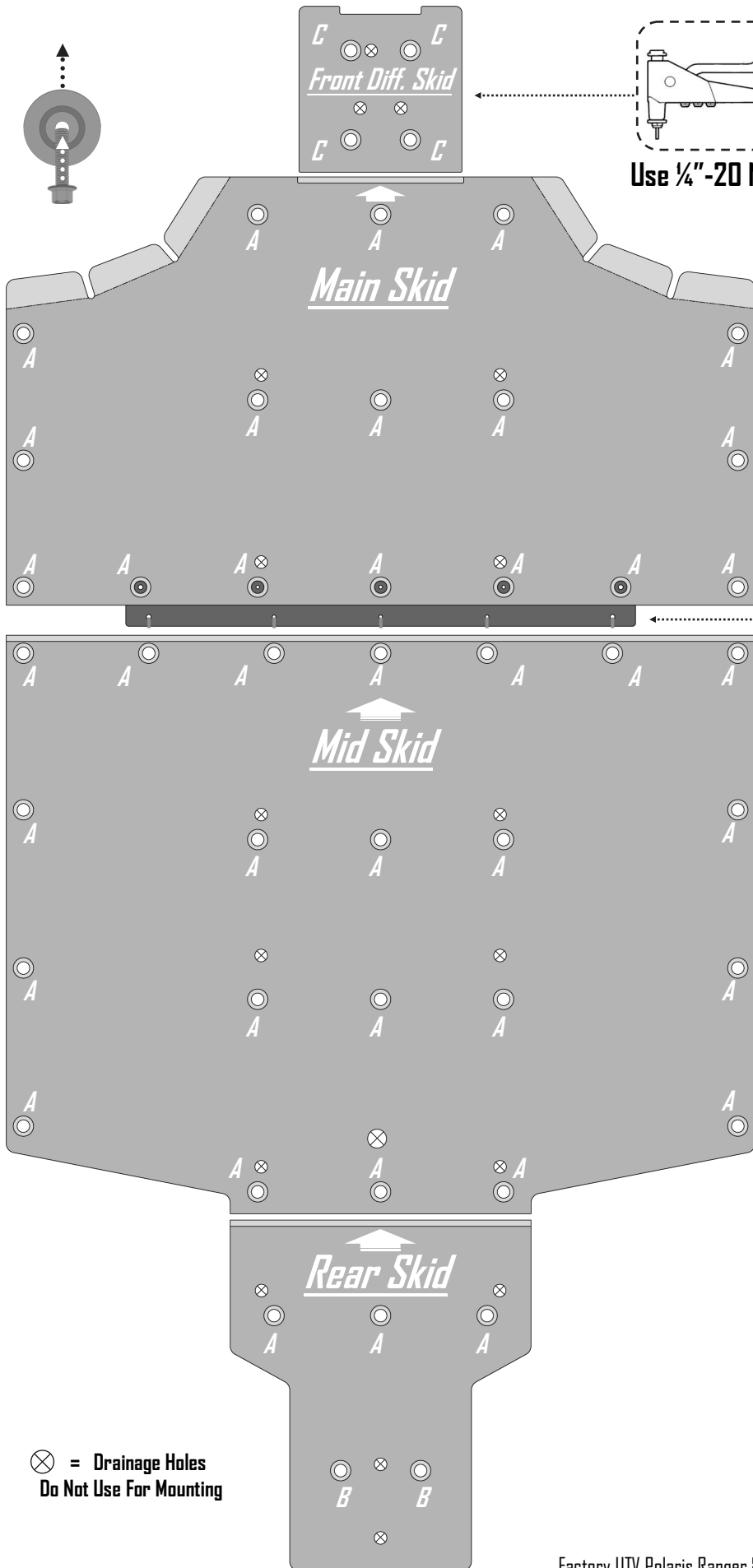

Use 1/4" -20 Nutsert tool



*(Align Edge)

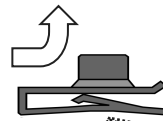

Install extension bracket with j-clip tips pointing up towards vehicle.

⊗ = Drainage Holes
 Do Not Use For Mounting

Polaris Ranger 800 Crew (2011-2014) Hardware kit

#1 Front Diff Skid Small Bag:

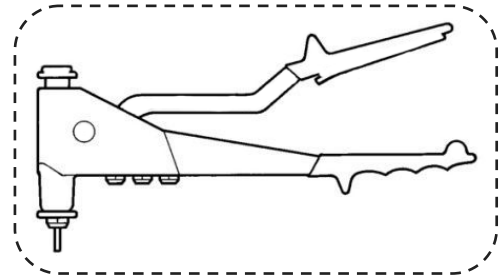
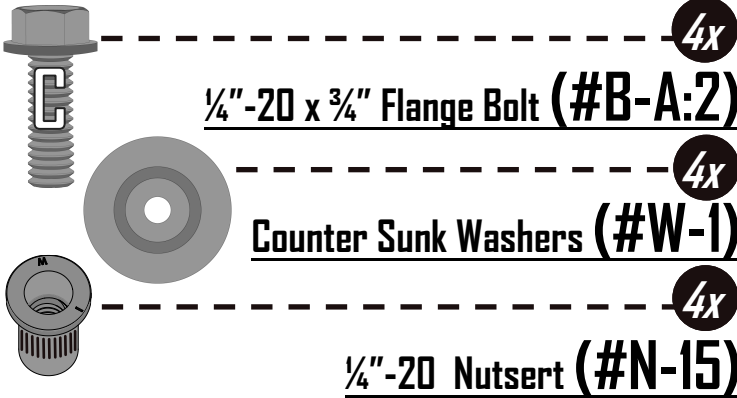

Use of a 1/4"-20 Nutsert tool required.
For front diff (C) locations
*(Nutsert tool not included)

#2 Main & Mid Skid Large Bag:

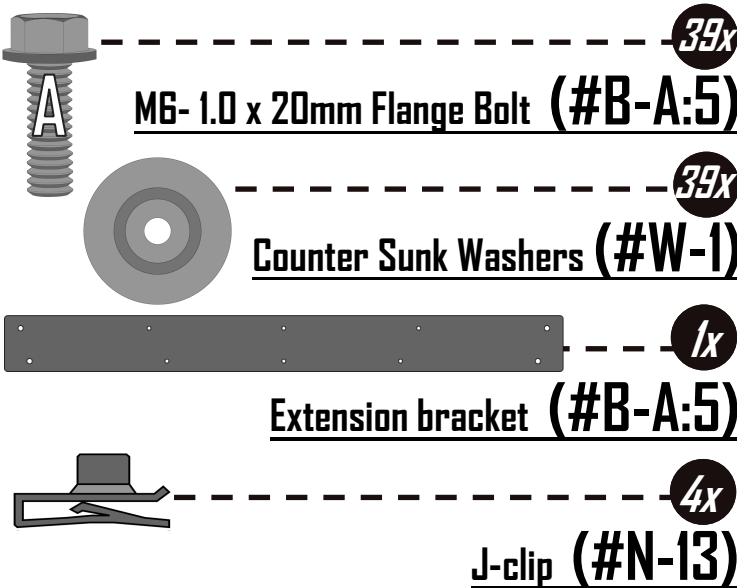

#3 Rear Skid Small Bag:

