

Contact Us: *FACTORY UTV LLC*

9237 Beatty Drive Sacramento, CA 95826

Phone : (916) 383-2730

E-mail : info@factoryutv.net

Go online: www.Factoryutv.net



U.H.M.W. Skid Plate / Under Armor Package

Ultra. High. Molecular. Weight. polyethylene all terrain skid plate / under armor kit for UTV's

Installation Guide (UHMW Skid Plate)

Polaris

RZR Pro XP (2020 - 2021+)



Polaris RZR Pro XP (2020 - 2021+) Skid Plate Instructions

Remove stock skid plate and re-use stock hardware as needed in all (A) locations use of 1/4" - 20 Tap *(Required)

#1

Main Skid Plate A :

Remove stock skid and install Extension Bracket, Cut Quarter Guards, ensure all are in place before skid install (see next page diagram)

Install Trailing Arm Fore Mount Guards with (1x) 1/4"-20 x 3/4" Counter sunk Bolt in (L.1) locations,

Mark, drill and tap remaining (L.2) locations. Then install with (2x) 1/4"-20 x 3/4" Counter sunk Bolt in (L.2) locations on each guard.

Install main skid plate using: (2x) Stock Bolts (M6 - 1.0x 20mm TF bolts) *In Main Skid Center: (A) locations,*

Install: (2x) M6- 1.0 x 35mm Flange Bolts *In main skid : (H) locations.*

Install: (4x) M6-1.0 x 25mm Flange Bolts *In main Skid: (I) locations.*

Leave bolts loose for adjustment, disregard remaining locations for later steps.

#2

Rear Skid Plate A :

Align edge with main skid plate, Install: (10x) Stock (M6 - 1.0x 20mm TF bolts) *In Rear Skid: (A) locations.*

**IF installing X-brace, install in-between skid and chassis frame before bolting in place.*

Leave bolts loose for adjustments, disregard remaining B locations for later steps.

#3

Front Diff. Skid Plate A :

Align edge with Main Skid mark (E) locations in back plate, (Using stock holes as guide)

**(See Drilling Instructions Below)* Drill and tap (E) locations, loosely install (2x) 1/4"-20 x 1" Self Taping Bolts.*

Leave bolts loose for adjustments, disregard remaining D,F,G locations for later steps.

#4

Skid Plate adjustments:

Align edge's of Skid, with bolts fastened loosely, adjust skid for best fit,
when correct, tighten currently installed bolt locations.



#5

Main Skid Plate B :

Remove and replace (3x) 1/4"-20 x 3/4" Self Taping Bolts from extension bracket, to keep bracket in place, remove and re-install these bolts through skid, one at a time with countersunk washers *in (B) locations.*

Mark, drill, tap and install (6x) 1/4"-20 x 3/4" Self Taping Bolts for remaining *main skid (B) locations.*

Mark, drill, tap (2x) holes for remaining *main skid (C) locations.*

Install: (2x) M6- 1.0 x 20mm Flange Bolts *In main skid : (C) locations.*

#6

Rear Skid Plate B :

Mark, drill, tap and install (4x) 1/4"-20 x 3/4" Self Taping Bolts for remaining (B) locations. Fasten bolts securely.

#7

Front Diff. Skid Plate B :

Mark, drill, tap and install (4x) 1/4"-20 x 1/2" Self Taping Bolts for remaining (D) locations. Fasten bolts securely.

F and G locations: Use a car jack and/or clamps to firmly bend diff skid up in to place, flush with plate below the tow hook.

Mark F location, Drill 13/64th holes perpendicular to metal plate, use 1/4"-20 Tap and

Install (1x) 1/4"-20 x 3/4" Counter sunk Bolt in (F) location.

Once (F) is installed, Mark G location, Drill 13/64th holes perpendicular to metal plate, use 1/4"-20 Tap and

Install (2x) 1/4"-20 x 1 1/4" Counter sunk Bolts in (G) locations.

Fasten bolts securely.

* Drilling Instructions : *

Use a : #No7 (13/64th) drill bit,

(one size above the commonly available 3/16th bit) use of 1/4" - 20 Tap *(Required)

To drill and thread self tapping bolts in to chassis frame.

Finger Thread All Bolts Prior To Fastening Securely With Power Tools.

We strongly recommend the use of a "Thread Locking Compound" when installing any mounting hardware.

(When installation is complete , ensure all bolts are fastened securely.)

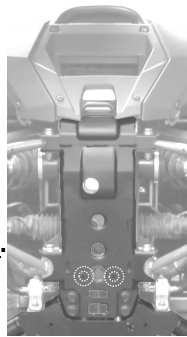

Polaris RZR Pro XP (2020 - 2021+) Skid Plate Install

Remove stock skid plate
Save Hardware for re-use.
Cut quarter guard panels,
Mount extension brackets
before skid install
1/4" - 20 Tap Required

Front Diff Skid

#3

Fasten bolts until flush
DO NOT over tighten

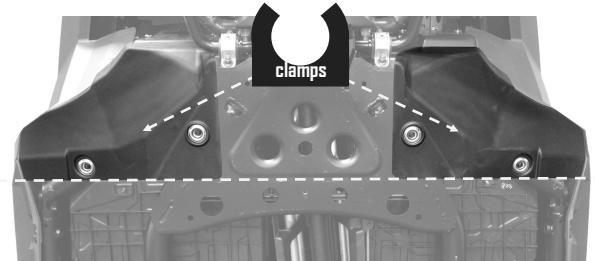
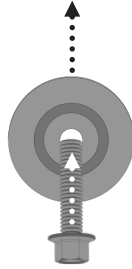
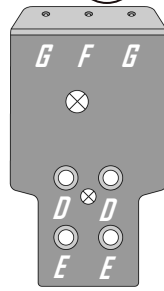

Cut and re-use stock skid plate "front quarter guards"
Use the center opening's "factory edge" to mark across stock skid below bottom (2x) bolt cups. Cut as needed.
Re-attach with built in plastic clamps before skid installation
skid plate utilizes same bolt locations.

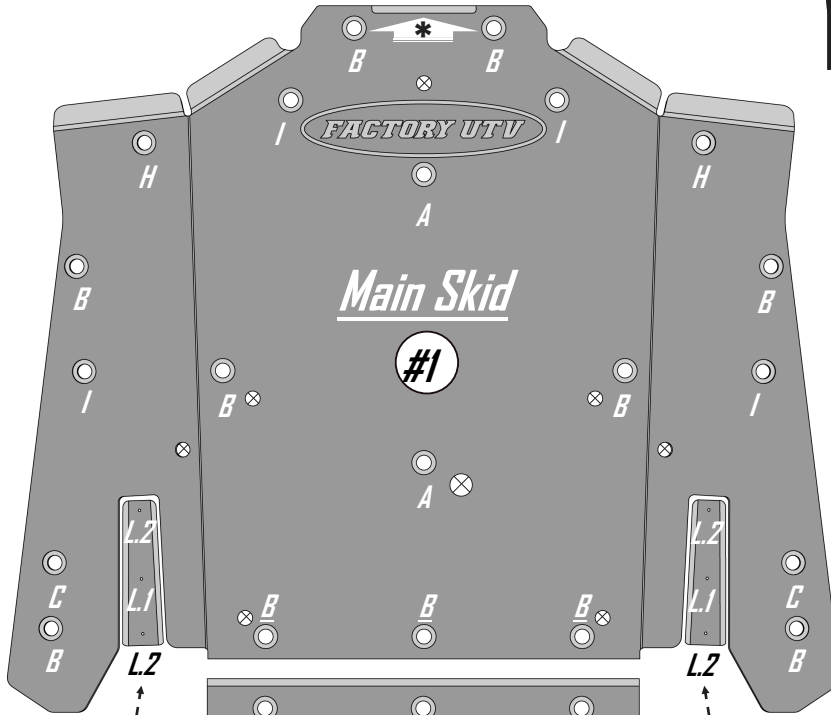

Trailing Arm Fore Mount Guards

Trailing Arm Fore Mount Guards

Rear Skid

#2

***If Installing X-Brace**
Mount in between skid and chassis frame,
X- brace uses same rear skid mounting.

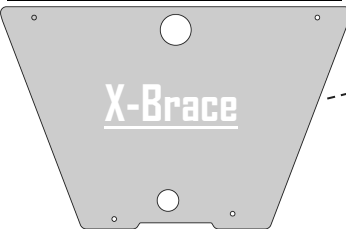



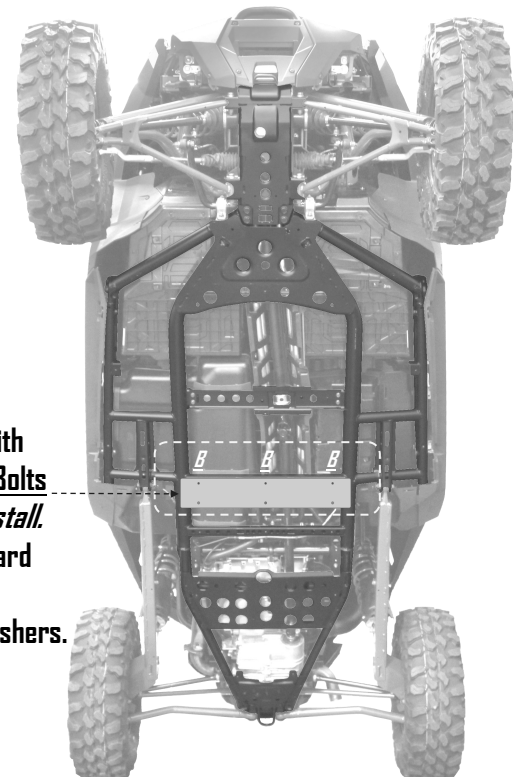

Install Extension bracket with (3x) 1/4" - 20 x 3/4" Self Taping Bolts in **B** locations, before skid install. with j-clip tips pointing upward towards the vehicle.
Install bolts loosely with out washers.





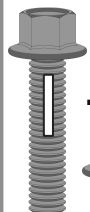
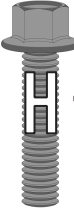

⊗ = Drainage Holes
Do Not Use For Mounting

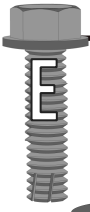

#1 Main Skid Large bag:

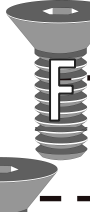
-  **11x**
1/4"-20 x 3/4" Self Taping Bolt (#B-D:2)
-  **2x**
M6- 1.0 x 20mm Flange Bolt (#B-A:5)
-  **4x**
M6- 1.0 x 25mm Flange Bolt (#B-A:6)
-  **2x**
M6- 1.0 x 35mm Flange Bolt (#B-A:8)
-  **19x**
Counter Sunk Washers (#W-1)



#3 Front Diff Skid small bag:

-  **2x**
1/4"-20 x 1" Self Taping Bolt (#B-D:3)
-  **2x**
1/4"-20 x 1/2" Self Taping Bolt (#B-D:1)
-  **1x**
1/4"-20 x 3/4" Counter sunk Bolt (#B-C:9)
-  **2x**
1/4"-20 x 1 1/4" Counter sunk Bolt (#B-C:2)
-  **4x**
Counter Sunk Washers (#W-1)

#1 Fore arm guard small bag:

-  **6x**
1/4"-20 x 3/4" Counter sunk Bolt (#B-D:2)
-  **1x**
Pro XP Extension Bracket (#E-B:13)
-  **3x**
J-Clip (installed on bracket) (#N-13)

#2 Rear Skid small bag:

-  **2x**
1/4"-20 x 3/4" Self Taping Bolt (#B-D:2)
-  **2x**
Counter Sunk Washers (#W-1)

Go online to www.FactoryUTV.net
and check out our other PRO XP products:

