

Contact Us: FACTORY UTV LLC

9237 Beatty Drive Sacramento, CA 95826

Phone : (916) 383-2730

E-mail : info@factoryutv.net

Go online: www.Factoryutv.net



U.H.M.W. Skid Plate / Under Armor Package

Ultra. High. Molecular. Weight. polyethylene all terrain skid plate / under armor kit for UTV's

Installation Guide (Ultimate package)

Kawasaki

MULE PRO (2016)

Fits : DX, DXT, FX, FXT, And EPS Models



Kawasaki MULE PRO (2016) Instructions

Remove stock skid plate and re-use stock hardware as needed in all (A) locations.

Skid's will form to vehicle during installation.

#0

Extension Bracket Mount & (A) bolt location:

Install (1x) Extension bracket using (2x) M6- 1.0 x 20mm Flange Bolt in chassis frame (B:1) locations.
in (A) location, Re-use (1x) Stock self tapping bolt : To tap or thread hole for use with (B) bolt with installation.
During installation, reinstall (B:1) bolts with a counter sunk washer after skid is in place.

#1

Main and Mid Skid Plates :

Install mid skid to extension bracket before main skid, align edge, note step (#0),

Mid Skid use: (12x) M6- 1.0 x 20mm Flange Bolt in Mid Skid: (B) locations.

Main Skid use: (11x) M6- 1.0 x 20mm Flange Bolt in Main Skid: (B) locations.

Defer side (D) locations Until Step (#4)

#2

Front Skid & Rear Skid Plate :

(See Drilling Instructions Below) Align, mark, & drill in : (C) locations.

Install: (10x) ¼"-20 x ¾" Self Tapping Bolts in (C) locations.



#3

Side Mounts W/ Rock Sliders (D):

(See Drilling Instructions Below)

Align, mark, drill, and Install: (14x) ¼"-20 x 1 ¼" Self Tapping Bolts in Main Skid : (D) locations.

Install rock sliders in-between skid plate and chassis frame .



A:1

A-Arm Guards (Front A:1) (Rear A:2)

Remove stock guards prior to fitting U.M.H.W. A-Arm Guards

Install : 1" x 1" -"D" Clamps (A:1) over front A-Arm tubing using a ¼"-20 x 1 ¼" Counter Sunk Bolts ,
with a ¼" Gold Washer, and a ¼"-20 Ny-Lock Nut in all: (A:1) locations.

Install : 1" x 1 ¼" -"D" Clamps (A:2) over rear A-Arm tubing using a ¼"-20 x 1 ¼" Counter Sunk Bolts ,
with a ¼" Gold Washer, and a ¼"-20 Ny-Lock Nut in all: (A:2) locations.



*** Ensure Clearance For Turn Radius & Vertical Travel
Before Fastening ALL Bolts Securely
(Tighten until bolts are flush with plastic)**

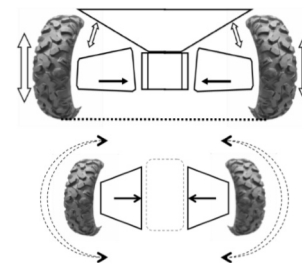

*** Drilling Instructions : ***

Use a : #No7 (13/64th) drill bit,

(one size above the commonly available 3/16th bit) Recommended ¼" - 20 Tap *(Optional)

To drill and thread self tapping bolts in to chassis frame.

Finger Thread All Bolts Prior To Fastening Securely With Power Tools.

We strongly recommend the use of a "Thread Locking Compound" when installing any mounting hardware.

(When installation is complete , ensure all bolts are fastened securely.)

Kawasaki MULE PRO (2016)

Read :
 Instructions on pg.#2
 Remove stock skid plate.
 Reuse hardware as needed.
 See drilling instructions
 prior to drilling.

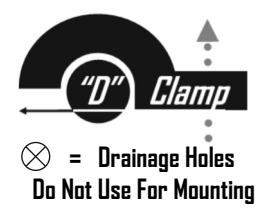
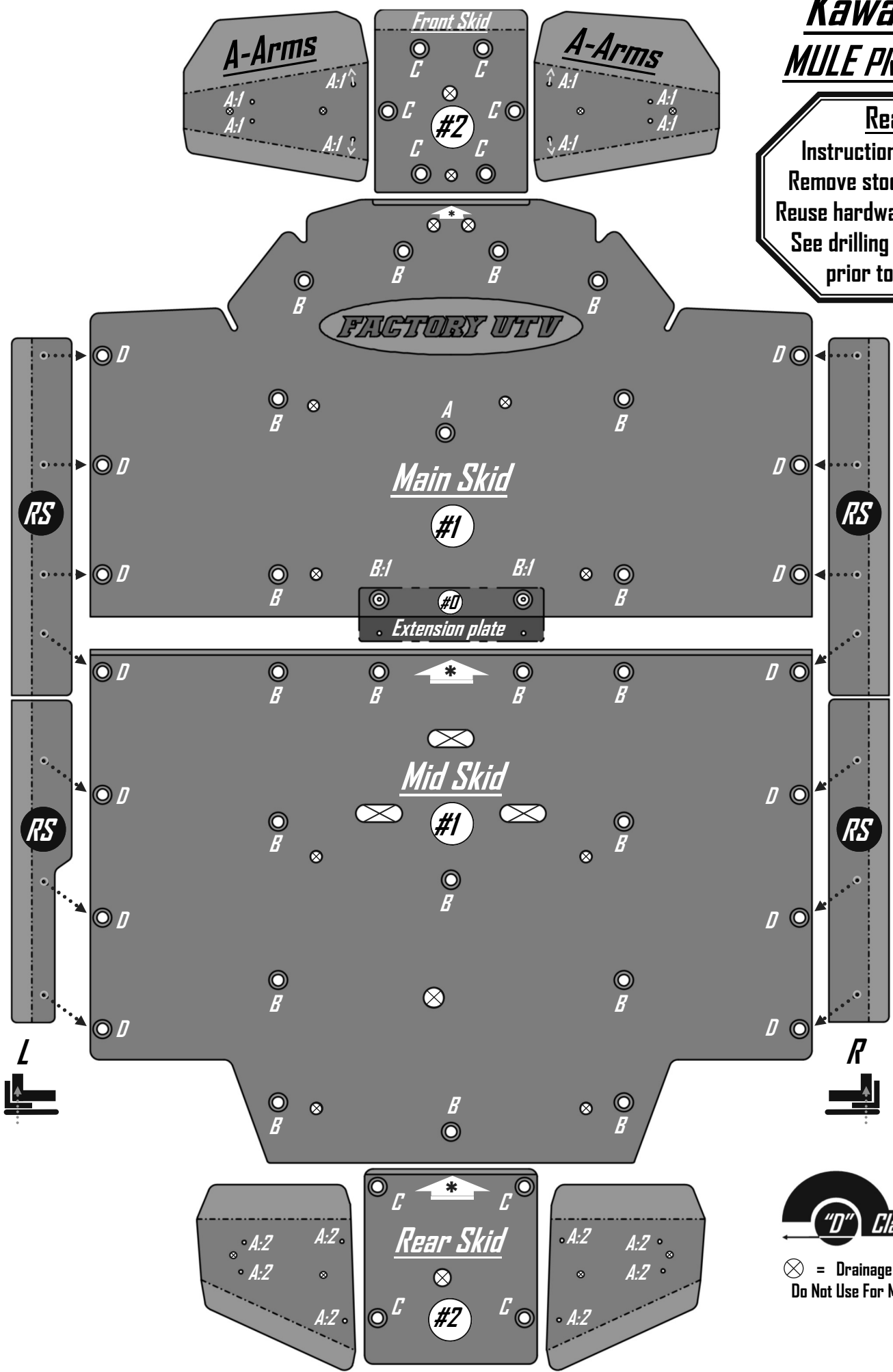

Kawasaki MULE PRO (2016) Hardware kit

Skid Plate Hardware

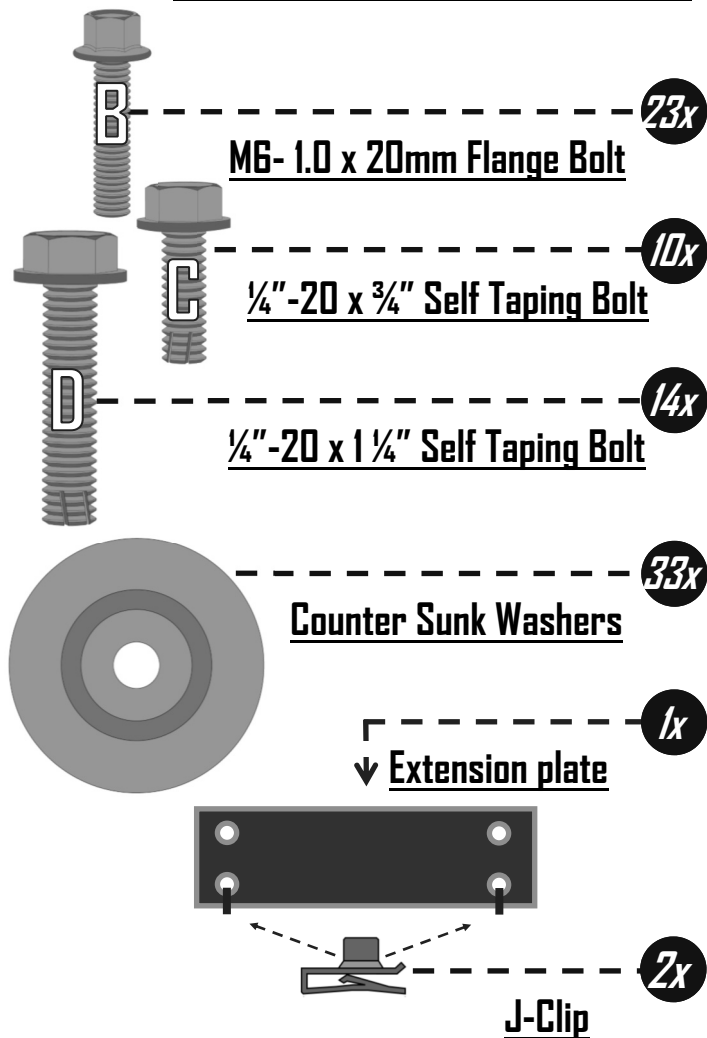

A-Arm Hardware



**(All bolt lengths here are sized to scale.)*

*** Drilling Instructions : ***

Use a : #N^o7 (13/64th) drill bit,

(One size above the commonly available 3/16th bit) Recommended use with a 1/4"- 20 Tap *(Optional)

To drill and thread self tapping bolts in to chassis frame.

Finger Thread All Bolts Prior To Fastening Securely With Power Tools.

We strongly recommend the use of a "Thread Locking Compound" when installing any mounting hardware.

(When installation is complete , ensure all bolts are fastened securely.)