

Contact Us: *FACTORY UTV LLC*

9237 Beatty Drive Sacramento, CA 95826

Phone : (916) 383-2730

E-mail : info@factoryutv.net

Go online: www.Factoryutv.net



FACTORY UTV

U.H.M.W. Skid Plate / Under Armor Package

Ultra. High. Molecular. Weight. polyethylene all terrain skid plate / under armor kit for UTV's

Installation Guide (Ultimate Package)

Polaris

RZR RS1 (2018+)



Polaris RZR RSI (2018+) instructions

Remove stock skid plate and re-use stock hardware as needed in all (A) locations.

S

Fender Spacers:

Remove stock side bolt. Install nylon spacer behind lower quarter panel, fasten "S" bolt through stock plastic panel and spacer, to ensure trailing arm guard travel clearance. *(see diagram pg.3)

#1

Main Skid Plate :

Install main skid using: (9x) Stock Bolts & Washers in Main Skid: (A) locations, *(See Drilling Instructions Below)* Mark, drill and install: (6x) $\frac{1}{4}$ "-20 x 1" Self Tapping Bolts in Main Skid: (B) locations.

#2

Rear Skid Plate :

Align edge with main skid plate Install: (6x) $\frac{1}{4}$ "-20 x 1" Self Tapping Bolts in Rear skid: (B) locations.

Install: (2x) $\frac{1}{4}$ "-20 x 1 $\frac{1}{2}$ " Self Tapping Bolt with (2x) Nylon Spacers in Rear skid: (E) locations.

(Mount forward bolts first, to aid positioning of rear spacers between skid and chassis frame. Do not over tighten)



#3

Front Diff. Skid Plate :

(See Drilling Instructions Below) Align edge with Main Skid.

Mark, drill and install: (4x) $\frac{1}{4}$ "-20 x $\frac{3}{4}$ " Self Tapping Bolts in Front Diff. Skid: (C) locations.

For Double Wall Plating in front two (C) locations use: (2x) $\frac{1}{4}$ "-20 x 1" Self Tapping Bolts

Drill larger $\frac{5}{16}$ " clearance holes in first layer, then drill and/or tap smaller hole in backing layer, use caution not to strip holes.

#4

Trailing Arm Fore Mount Guards :

Install: (1x) $\frac{1}{4}$ "-20 x 1" Counter sunk Torx Bolt in fore mount guard: Rear (T) location.



Check direction make sure the high side is outward, Avoid over tightening, Fasten until bolt heads are even with plastic.

In front "T" locations: *(See Drilling Instructions Below), drill or thread (1x) $\frac{1}{4}$ "-20 x 1" Counter sunk Torx Bolt in place.

Install: (1x) $\frac{1}{4}$ "-20 x 3" Hex Head Bolt, (2x) $\frac{1}{4}$ " Silver Washers and (1x) Nylock nuts in fore mount guard: Side (G) locations.

G

Trailing Arm Guards : (G)

Install : (3x) $\frac{1}{4}$ "x 20 x 3" Hex Bolts W/ (6x) $\frac{1}{4}$ " Zinc Washers, and (3x) $\frac{1}{4}$ "x 20 Ny-Lock Nuts

In : (G) locations. (on Each Trailing Arm Guard).

D+E

A-Arm Guards (D) & (E)

Install : (3x) "D" clamps over A-Arm tubing W/ (3x) $\frac{1}{4}$ "-20 x 1 $\frac{1}{4}$ " Counter Sunk Bolts,

(3x) $\frac{1}{4}$ " Gold Washers, and (3x) $\frac{1}{4}$ "-20 Ny-Lock Nuts in: (D) locations.

Install : (2x) $\frac{1}{4}$ "-20 x 1 $\frac{1}{2}$ " Counter Sunk Bolts, W/ (2x) $\frac{1}{4}$ " Gold Washers, and (2x) $\frac{1}{4}$ "-20 Ny-Lock Nuts through stock mounting holes at apex of A-Arm in: (E) locations. (on Each A-Arm Guard)

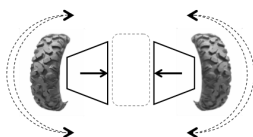

*** Ensure Clearance For Turn Radius & Vertical Travel**

Before Fastening ALL Bolts Securely

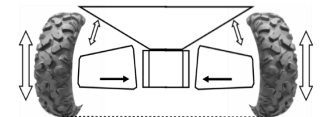

*** Drilling Instructions : ***

Use a : #No7 (13/64th) drill bit,

(one size above the commonly available 3/16th bit) Recommended $\frac{1}{4}$ "-20 Tap *(Optional)

To drill and thread self tapping bolts in to chassis frame.

Finger Thread All Bolts Prior To Fastening Securely With Power Tools.

We strongly recommend the use of a "Thread Locking Compound" when installing any mounting hardware.

(When installation is complete , ensure all bolts are fastened securely.)

Polaris RZR RS1 (2018+) instructions

Read :
 Instructions on pg.#2
 Remove stock skid plate,
 reuse hardware as needed.
 Skid plate will form to fit.
 See drilling instructions
 prior to drilling.

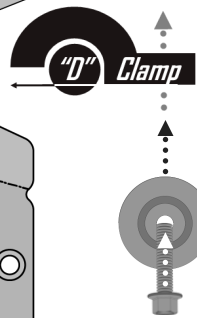
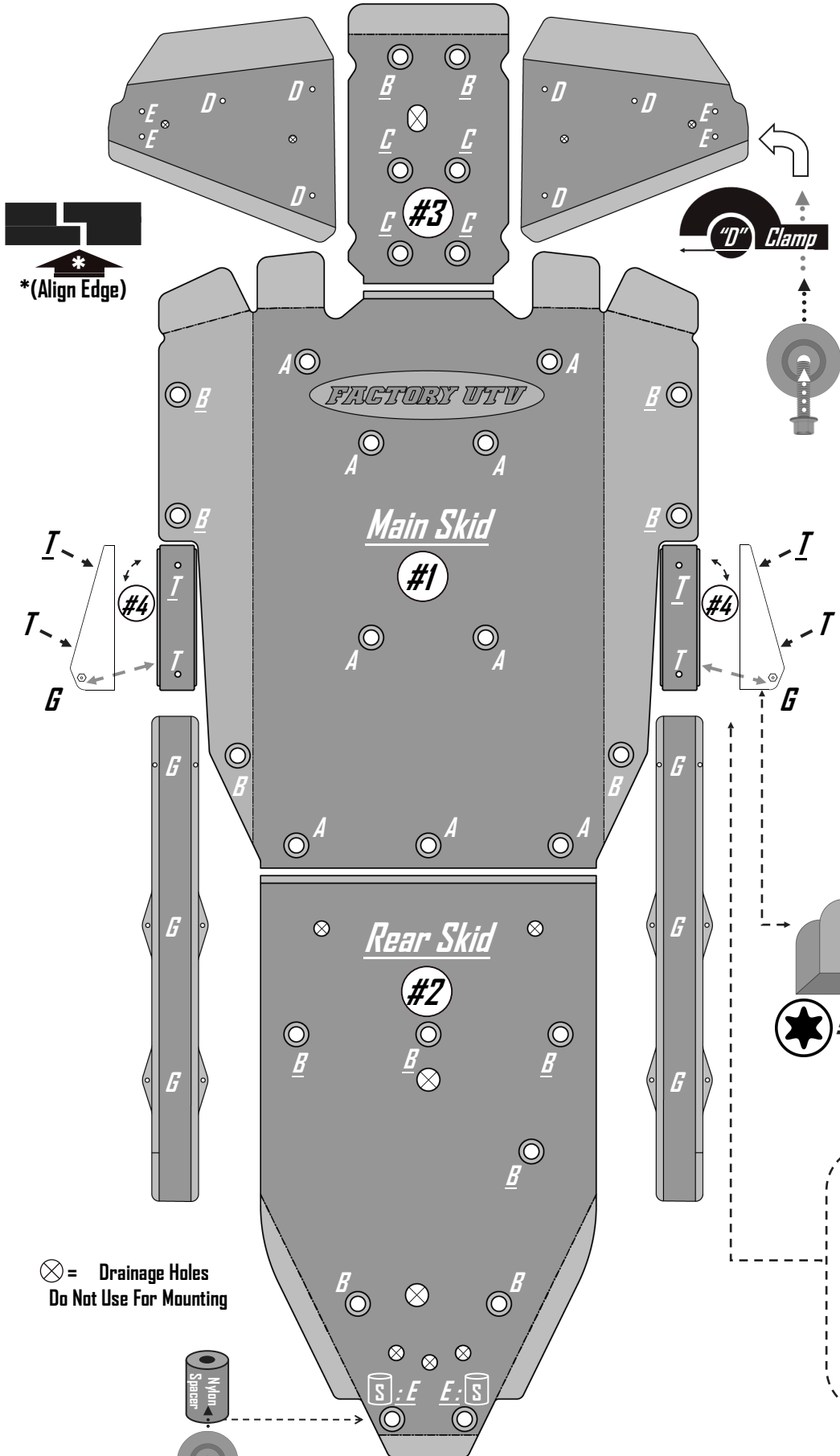

Front Diff Double Wall Plating:
 Drill a larger $\frac{5}{16}$ clearance hole in first layer,
 then drill and/or tap smaller hole in backing layer.
USE CAUTION WHILE DRILLING
 *(If self tapping bolts strip out and do not mount, use
 a 1/4-20 nut and bolt, install with boxed end wrench)

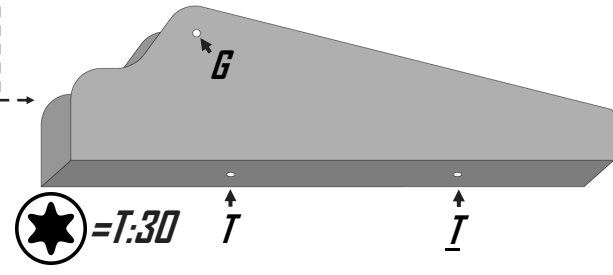
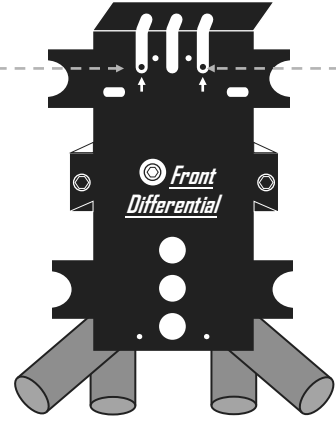

⊗ = Drainage Holes
 Do Not Use For Mounting

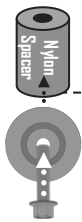

**Install Nylon Spacer, Bolt, & Washer.
 Fasten Securely, Do Not Overtighten.**

Body panel spacers:
 Remove stock side bolt. Install nylon spacer
 behind lower quarter panel, fasten "S" bolt
 through stock plastic panel and spacer,
 ensure trailing arm guard clearance.

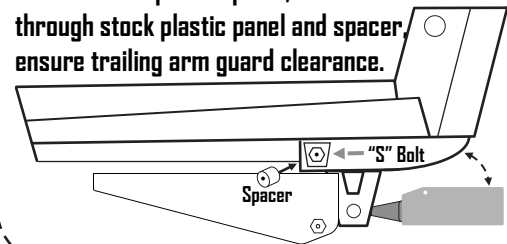

Polaris RZR RSI (2018+) Skid plate Hardware

#1 Main Skid Small bag:



----- 2x

1/4"-20 x 1" Self Taping Bolt (#B-D:3)

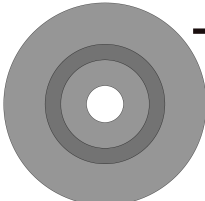

----- 6x

Counter Sunk Washers (#W-1)

#2 Rear Skid small bag:

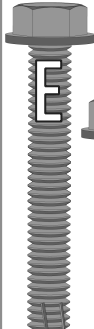

----- 2x

1/4"-20 x 1 1/2" Self Taping Bolt (#B-D:6)

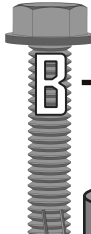

----- 6x

1/4"-20 x 1" Self Taping Bolt (#B-D:3)



----- 2x

3/4" Nylon Spacers (#S-R:4)



----- 8x

Counter Sunk Washers (#W-1)

#3 Front Diff Skid small bag:



----- 2x

1/4"-20 x 1" Self Taping Bolt (#B-D:3)



----- 4x

1/4"-20 x 3/4" Self Taping Bolt (#B-D:2)

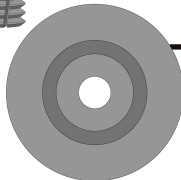

----- 6x

Counter Sunk Washers (#W-1)

#4 Fore mount guards small bag:



----- 2x

1/4"-20 x 3" Hex Flange Bolt (#B-H:8)



----- 4x

1/4"-20 x 1" Torx Bolts (#B-T:4)



----- 4x

Zinc Washers (#W-4)



----- 2x

1/4"-20 Ny-Lock Nut (#N-3)

#5 Fender spacers small bag:



----- 2x

M6- 1.0 x 35mm Flange Bolt (#B-A:8)



----- 2x

3/4" Nylon Spacers (#S-R:4)

Polaris RZR RS1 (2018+) A-arm and trailing arm guard Hardware

#A

A-Arm large bag:

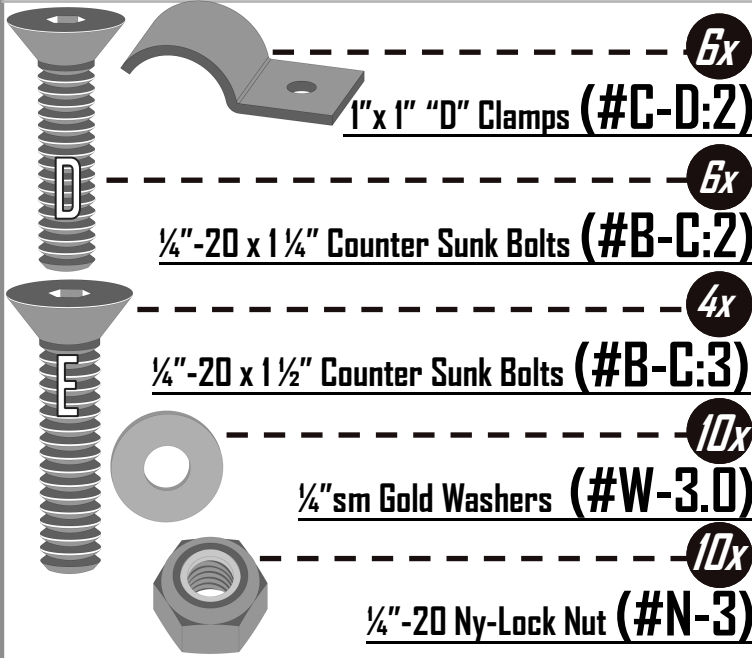

#T

Trailing arm small bag:

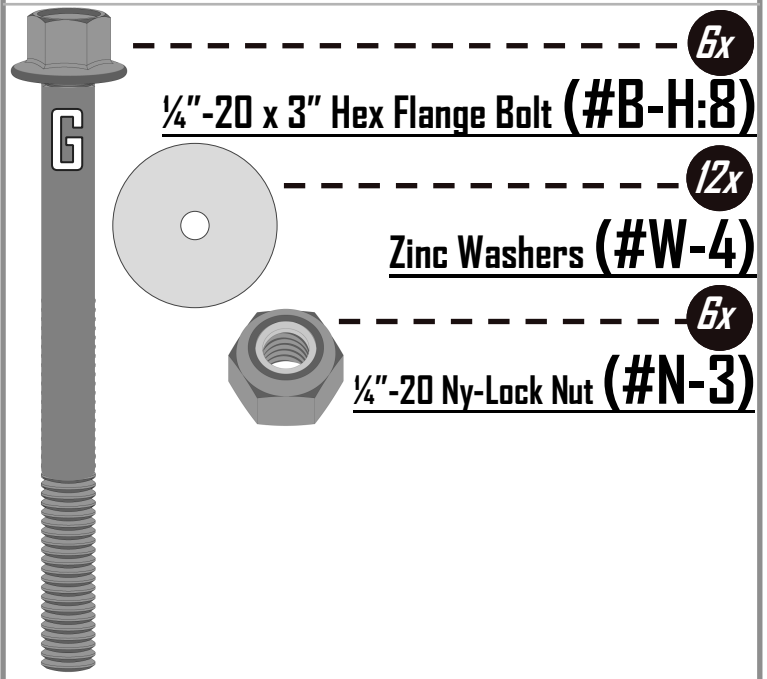

Polaris RZR RS1 (2018+) Other Accessories

Check out our other RS1 Accessories online at

www.Factoryutv.net

Restraint systems, Roll cage's and nerf bars



Front, Rear bumpers and spare tire mounts



High density upper door inserts

