

Contact Us: *FACTORY UTV LLC*

9237 Beatty Drive Sacramento, CA 95826

Phone : (916) 383-2730

E-mail : info@factoryutv.net

Go online: www.Factoryutv.net



U.H.M.W. Ultimate Skid Plate Package

Ultra. High. Molecular. Weight. polyethylene all terrain skid plate / under armor kit for UTV's

Polaris RZR 200

(2022+)

Installation Guide



Polaris RZR 200 (2022+) Instructions

#1

Main Skid Plate :

You may need assistance, or the use of a car jack, to help hold skid in place. Ensure vehicle is secure & in park. Install: (4x) M8 1.25x20mm Button head Torx Bolt (#B-B:6), (4x) Counter sunk washers (W-1.b) in Main Skid: (B) locations loosely.

Mark, Drill, (optional tap) (13x) Main Skid : (A) locations. and install:

(13x) 1/4"-20 x 3/4" Self Taping Bolt (#B-D:2) with (13x) Counter sunk washers (W-1) in Main Skid : (A) locations.

Start installing with the center (A) locations, (deferring side (A) locations) then Remove B Bolts.

Install Rocksliders inward from sides, in-between skid plate and chassis frame, Re-install (B) and (A) Bolts Securely.

#2

Front Diff. Skid Plate :

Un-fasten 2x front lower Torx bolts in lower front plastic. Re-install with front diff skid plate, using 2x front stock bolts with (2x) Counter sunk washers (W-1) in Front Diff. Skid : (D) locations.

Mark and Drill, (optional tap), (2x) Front Diff. Skid : (D) locations.

Install (2x) 1/4"-20 x 1/2" Self Taping Bolt (#B-D:5) with (2x) Counter sunk washers (W-1) in Front Diff. Skid : (D) locations.

Finger thread and Fasten all bolts loosely to allow for skid adjustments, (if needed) and then tighten all securely.

#3

Mid Skid Plate :

Align edge in to main skid plate, install D Clamp over frame tubing, In the arrowed directions shown on page 3, (2x) 1/2" x 1 1/4" "D" Clamps (#C-D:4) with (2x) M6- 1.0 x 20mm Flange Bolt (#B-A:5) and (2x) Counter sunk washers (W-1) in Front Diff. Skid : (E) locations. Defer (A) and (F) locations Until Step 4.

Finger thread and Fasten all bolts loosely to allow for skid adjustments.

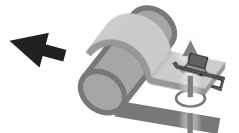

#4

Rear Skid Plate :

Align edge and slide bolts into Mid & rear skid, install remaining D Clamps In the arrowed directions shown on page 3, (2x) 1/2" x 1 1/4" "D" Clamps (#C-D:4) with (2x) M6- 1.0 x 30mm Flange Bolts (#B-A:7) and (2x) Counter sunk washers (W-1) in Front Diff. Skid : (F) locations. Fasten all bolts securely.

Mark and Drill, (optional tap), Remaining (3x) Rear Diff. Skid : (A) locations.

(2x) 1/4"-20 x 1/2" Self Taping Bolt (#B-D:5) with (2x) Counter sunk washers (W-1) in Rear Diff. Skid : (A) locations.

#a

A-arm Guards :

Install guards with D Clamps over A-arm frame tubing, using (8x) 1" x 1" "D" Clamps (#C-D:2), (8x) 1/4"-20 x 1 1/4" Counter Sunk Bolts (#B-C:2), (8x) 1/4" sm Gold Washers (#W-3) and (8x) 1/4"-20 Ny-Lock Nuts (#N-2) in A-Arm Guard : (a) locations. Fasten loosely to allow for adjustments before tightening until flush, do not over tighten.

#t

Trailing arm Guards :

Remove rear wheels, install bolts from outside towards center. use of clamps are required for installation, install: (6x) 1/4"-20 x 3" Hex head Bolts (#B-H:8), (12x) 1/4" sm Gold Washers (#W-3) and (6x) 1/4"-20 Ny-Lock Nuts (#N-2) in Trailing arm Guard: (t) locations. Clamp in to position, Re-clamp per each bolt location to reach fastener.

Fasten until UHMW is snug and tight, the UHMW will form to the Vehicael over time.

*** Drilling Instructions : ***

Use a : **#No7 (13/64th)** drill bit,

(one size above the commonly available 3/16th bit) Recommended 1/4"-20 Tap *(Optional)

To drill and thread self tapping bolts in to chassis frame.

Finger Thread All Bolts Prior To Fastening Securely With Power Tools.

We strongly recommend the use of a "Thread Locking Compound" when installing any mounting hardware.

(When installation is complete , ensure all bolts are fastened securely.)

Polaris RZR 200 (2022+)

Installation

Requires:

= T:20, T30 = 5/32
 = 10mm = 3/8 = 7/16
Drill Bits **(1/4"-20) Tap** **Clamps**
 13/64th

7/16"
 5/32"
 Fasten bolts until flush
 DO NOT over tighten

Re use Stack bolts with counter sunk washers in front 2 locations

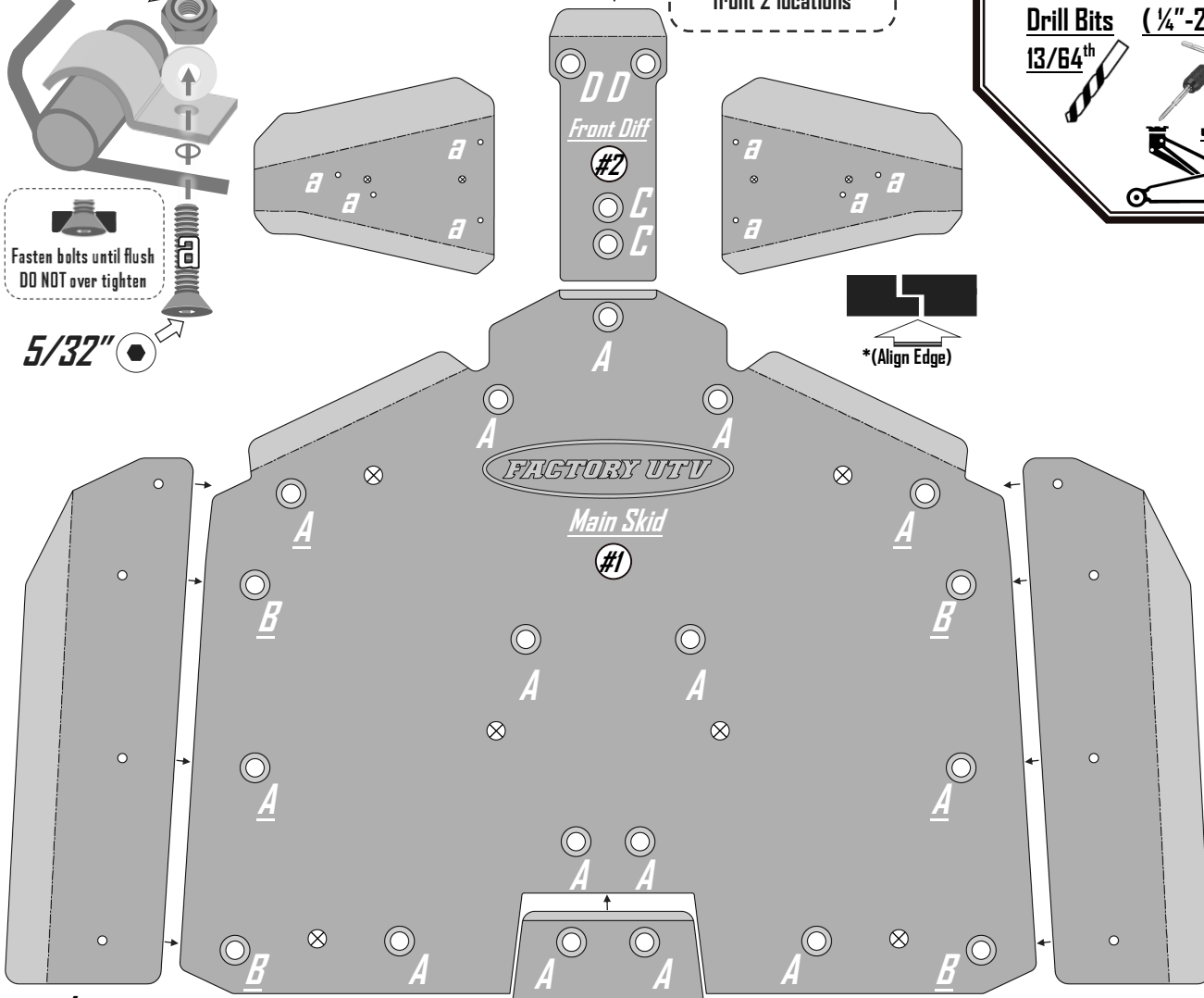

A 13/64th
 Drill 13/64th hole in (A) locations

Use (1/4"-20) Tap in (A) locations

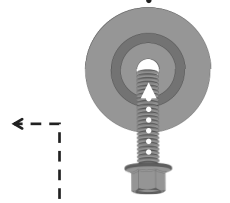

Rocksliders
 Install in-between skid plate & chassis. tighten loosely before fastening securely.

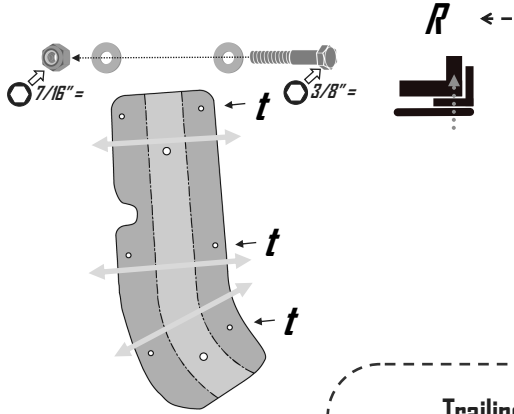
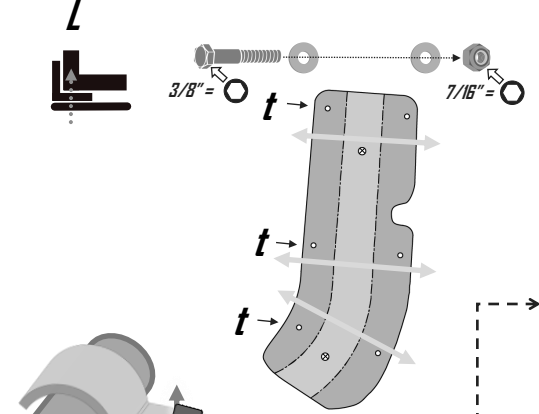

Install 4 Clamps in Arrowed Directions in (E + F) locations

= 10mm = Drainage Holes Do Not Use For Mounting

Trailing arm guards
 Removal of rear wheels required. Use of 2 or 3 Clamps to pinch and fasten for trailing arm guard hardware. Install bolts from outside towards the center. May need to clamp top -to- bottom initially, and then pinch together to reach each bolt. Guards will form to a tight fit over time.

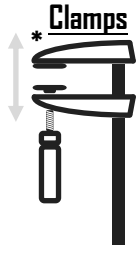

Polaris RZR 200 (2022+) Hardware kit

#1 Main Skid Large bag :

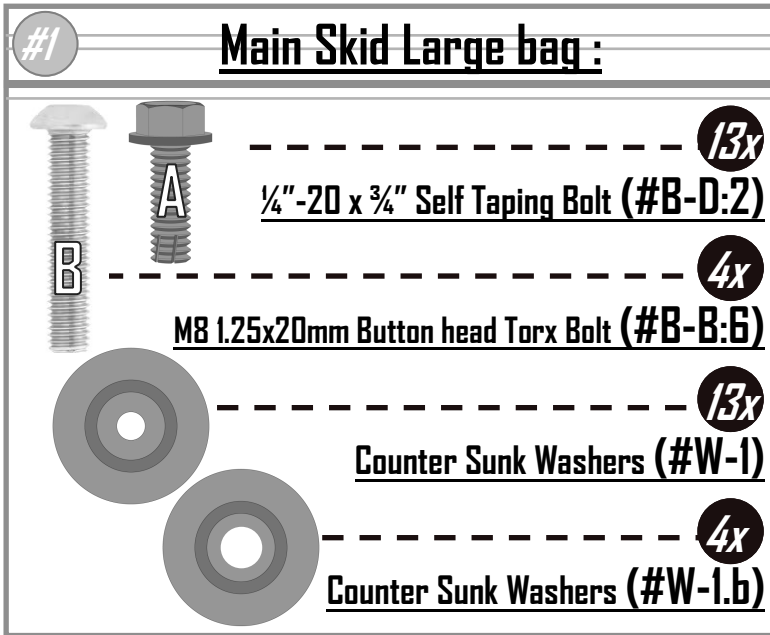

- A** 1/4"-20 x 3/4" Self Taping Bolt (#B-D:2) 13x
- B** M8 1.25x20mm Button head Torx Bolt (#B-B:6) 4x
- C** Counter Sunk Washers (#W-1) 13x
- D** Counter Sunk Washers (#W-1.b) 4x

#2 Front Diff. Skid small bag :

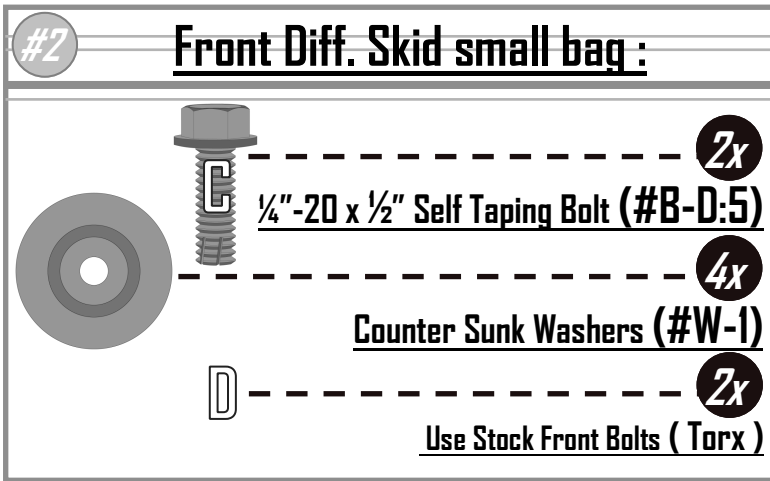

- E** 1/4"-20 x 1/2" Self Taping Bolt (#B-D:5) 2x
- F** Counter Sunk Washers (#W-1) 4x
- G** Use Stock Front Bolts (Torx) 2x

#3 Mid Skid Large bag :

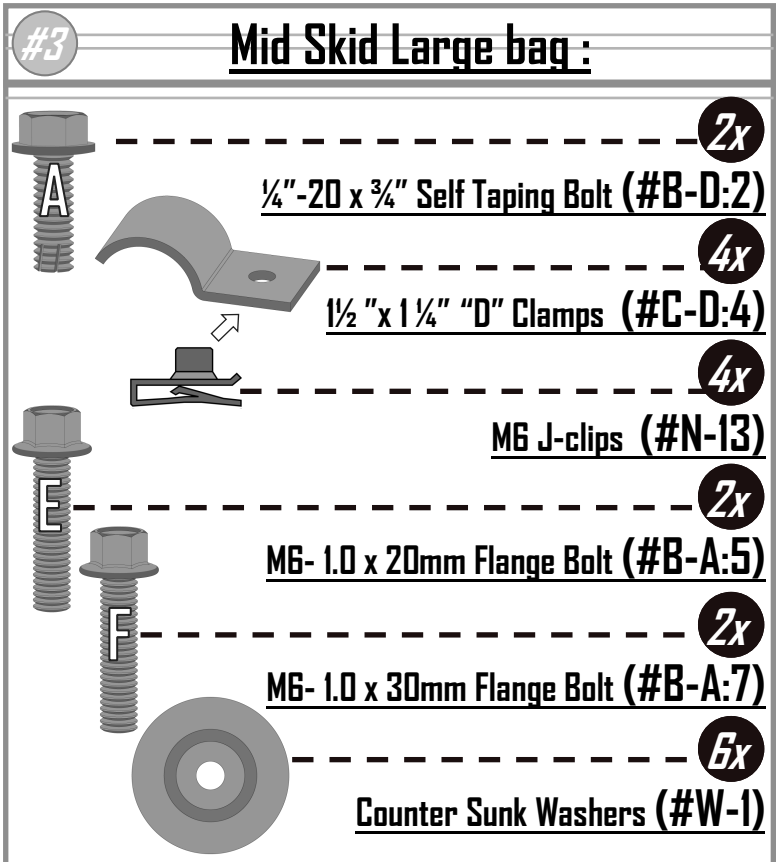

- H** 1/4"-20 x 3/4" Self Taping Bolt (#B-D:2) 2x
- I** 1/2" x 1 1/4" "D" Clamps (#C-D:4) 4x
- J** M6 J-clips (#N-13) 4x
- K** M6- 1.0 x 20mm Flange Bolt (#B-A:5) 2x
- L** M6- 1.0 x 30mm Flange Bolt (#B-A:7) 2x
- M** Counter Sunk Washers (#W-1) 6x

#4 Rear Diff. Skid small bag :

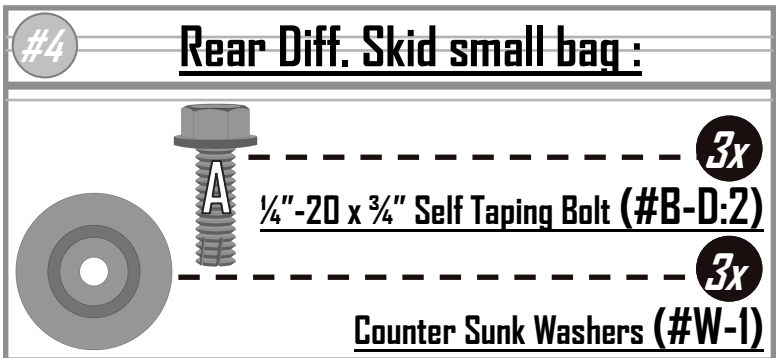

- N** 1/4"-20 x 3/4" Self Taping Bolt (#B-D:2) 3x
- O** Counter Sunk Washers (#W-1) 3x

#A Front A-Arm Guards Large bag :

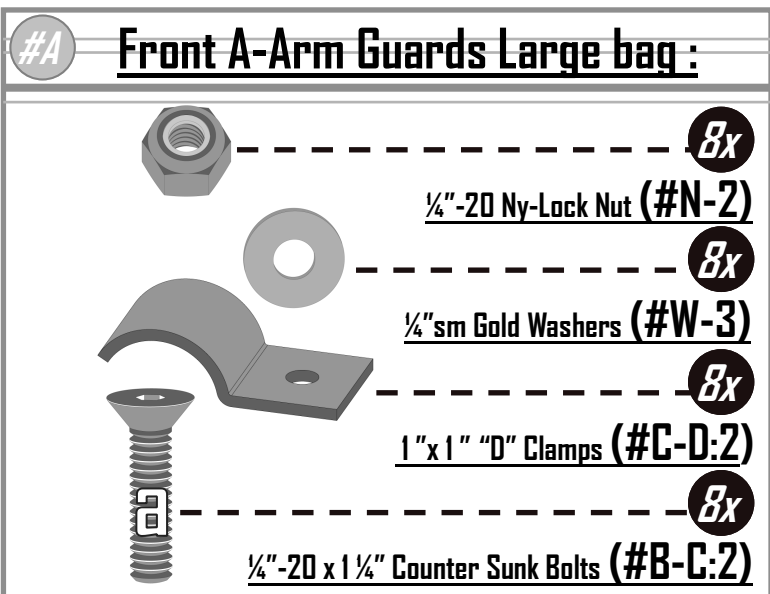

- P** 1/4"-20 Ny-Lock Nut (#N-2) 8x
- Q** 1/4" sm Gold Washers (#W-3) 8x
- R** 1"x1" "D" Clamps (#C-D:2) 8x
- S** 1/4"-20 x 1 1/4" Counter Sunk Bolts (#B-C:2) 8x

#T Rear Trailing Arm Guards small bag :

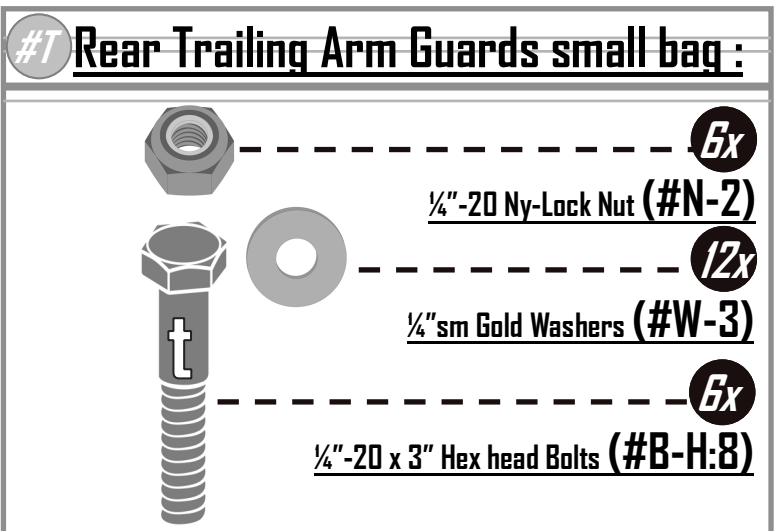

- T** 1/4"-20 Ny-Lock Nut (#N-2) 6x
- U** 1/4" sm Gold Washers (#W-3) 12x
- V** 1/4"-20 x 3" Hex head Bolts (#B-H:8) 6x