

Contact Us: *FACTORY UTV LLC*

9237 Beatty Drive Sacramento, CA 95826

Phone : (916) 383-2730

E-mail : info@factoryutv.net

Go online: www.Factoryutv.net



U.H.M.W. Skid Plate / Under Armor Package

Ultra. High. Molecular. Weight. polyethylene all terrain skid plate / under armor kit for UTV's

Installation Guide (Ultimate Package)

Polaris
General 4 1000 EPS (2016-2020+)



Polaris General 4 1000 EPS (2016 – 2021+) Instructions

#1

Remove stock skid plate. Re-use stock hardware as needed in all (A) locations.

Remove (5x) T-40 Torx bolts from each plastic side panel to remove skid. (see step 1 diagram, on pg 3)

#2

Install Mid and Rear Extension brackets.

Use: (2x) stock bolts without washers, to hold extension brackets in (A) locations during skid plate install.

Ensure mid extension bracket notch is in the bottom right corner *(as shown in page 3.) Mount with J-clips Tip's facing inward toward vehicle.

Remove and Re-install bolts with washers during skid plate installation.

#3

Rear Skid Plate :

Install: (2x) M6-1.0 x 30mm Flange Bolts in *Rear skid: (E) locations.*

Install: (3x) Stock bolts in *Rear skid: (A) locations.* *(note step 2, and adjust to fit before fastening)

Mark, drill and Install: (2x) ¼"-20 x 1" Self Tapping Bolts in *Rear skid: (C) locations.* *(See Drilling Instructions Below)*



#4

Main & Mid Skid Plate :

Skid plate will fit inside/under side panel plastic, slightly pull panel away from vehicle to fit in place. (see step 1 diagram on pg 3)

Install: (7x) Stock Bolts in *Mid Skid: (A) locations.* Align edge with rear skid, and extension brackets.

Install: (2x) M6-1.0 x 25mm Flange Bolts in *Center Mid Skid: (D) locations.* Align edge and Install main skid.

Install: (5x) Stock Bolts in *Main Skid: (A) locations.* Align edge with mid skid plate.

Install: (2x) M6-1.0 x 25mm Flange Bolts in *Center Main Skid: (D) locations.*

Install: (4x) M6-1.0 x 25mm Flange Bolts with "D" Clamps over tubing in *Main Skid: (D*) locations.* Defer side (B) locations Until Step (#6)

XP 1000 models : Remove plastic push rivets in fenders, to install (D) clamps behind fender well (See XP 1000 diagram on pg 3.)*



#5

Front Diff. Skid Plate :

(See Drilling Instructions Below) Align edge, mark, drill & install: (4x) ¼"-20 x ¾" Self Tapping Bolts in *Diff. Skid : (B) locations.*

#6

Side Mounts (B):

(See Drilling Instructions Below)

Align, mark, drill, and Install: (14x) ¼"-20 x ¾" Self Tapping Bolts in *Main and Mid Skid : (B) locations.*

Skid plate will fit inside/under side panel plastic, slightly pull panel away and/or wedge from vehicle, to help fit in place.

Ensure to fasten side panel bolts when complete (see figure on bottom of page 3.)

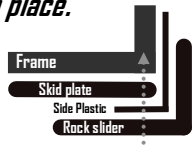

RS

If installing with Rock Sliders :

Use: "RS" (14x) ¼"-20 x 1 ¼" Self Tapping Bolts in *main skid: (B) locations, In lieu of side (B) bolts.*

Follow step (#4), Align, mark, drill all (B) locations, Ensure to fasten torx side panel bolts (see figure on bottom of page 3.)

then install Rocksliders over lip of stock side panel plastic, Drill or cut pass-through holes in side plastic as necessary.

Fasten all bolts securely. Rocksliders will mount on the exterior of skid plate and side plastic. Skid will form fit to chassis over time.

A-Arm Guards : Standard or High Clearance

High Clearance A-Arms: Install: ¼"-20 x 1" Counter Sunk Bolts and "D" clamps over A-Arm tubing,

with ¼" Gold Washers, and ¼"-20 Ny-Lock Nuts in each bolt locations.



Standard A-Arms: Install : ¼"-20 x 1" Counter Sunk Bolts with ¼" Gold Washer, and ¼"-20 Ny-Lock Nuts in each: (A-1) location.

Install : ¼"-20 x 1 ½" Counter Sunk Bolts with "D" clamps over A-Arm tubing in each front: (A:2*) location.

Install : ¼"-20 x 2 ½" Counter Sunk Bolts with "Box" clamps over A-Arm tubing in each Rear: (A:3*) location.

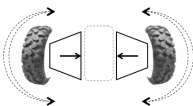

*** Ensure Clearance For Turn Radius & Vertical Travel**

Before Fastening ALL Bolts Securely

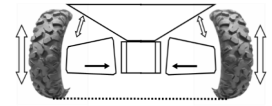

* Drilling Instructions : *

Use a : #Nº7 (13/64th) drill bit,

(one size above the commonly available 3/16th bit) Recommended ¼"-20 Tap *(Optional)

To drill and thread self tapping bolts in to chassis frame.

Finger Thread All Bolts Prior To Fastening Securely With Power Tools.

We strongly recommend the use of a "Thread Locking Compound" when installing any mounting hardware.

(When installation is complete , ensure all bolts are fastened securely.)

Polaris General 4 1000 EPS (2016 - 2021+)

See drilling instructions prior to drilling.
Remove stock skid plate, Reuse hardware as needed.
Before Skid plate installation, follow steps 1 and 2

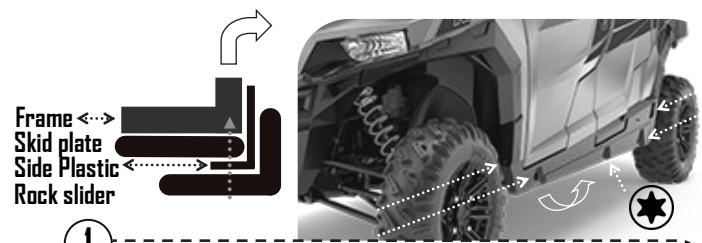
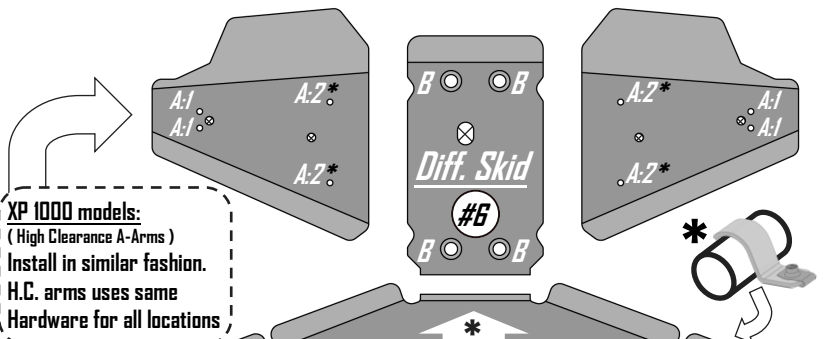

1 Remove: (5x) T - 40 Torx bolts on each lower side panel, Gently pull side plastics out, to fit skid plate inside lower plastic lip. Re-fasten Torx bolts securely when skid plate install is complete.

2 **Install Extension Brackets**
Use: (2x) stock bolts without washers to hold extension brackets in A locations, Mount with J-clips Tip's facing inward toward vehicle. Remove and Re-install bolts with washers during skid plate installation. Mount: (Mid) Extension Bracket with notch facing the bottom right corner.

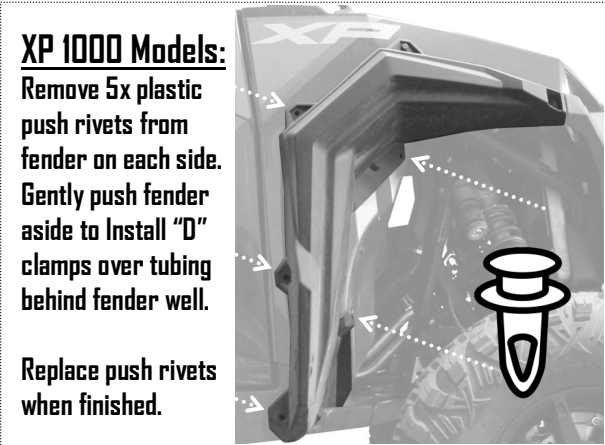
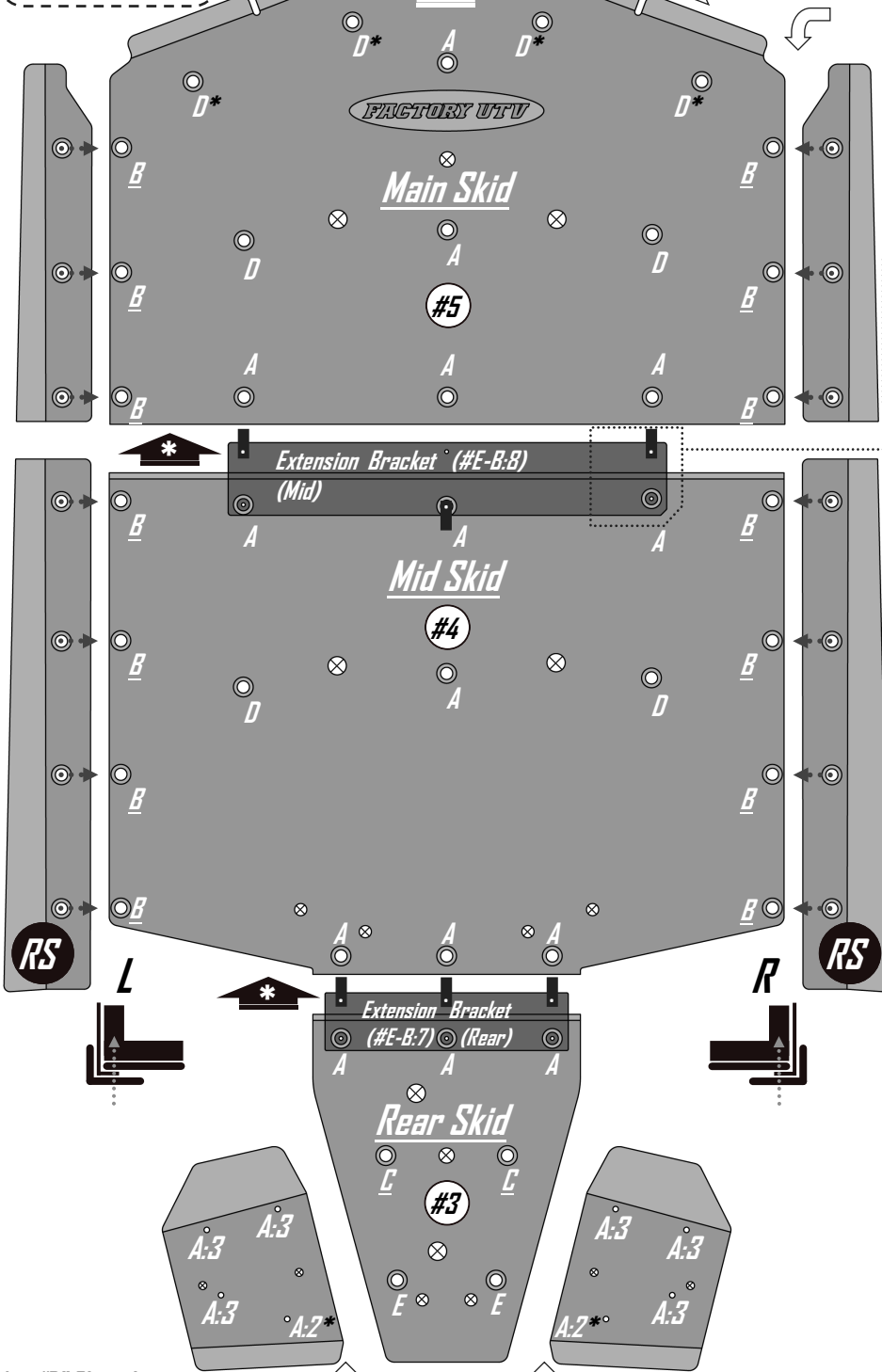
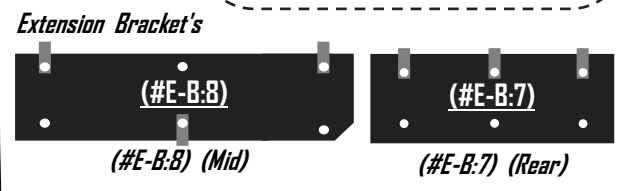
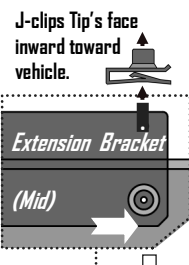



* = "D" Clamp locations
_ = Drilling locations
⊗ = Drainage Holes
Do Not Use For Mounting

Rear A-arm guards for Non-XP 1000 Models only (coming soon)

#2 Main Skid Large bag:

 **M6- 1.0 x 25mm Flange Bolt (#B-A:6)** **8x**

 **Counter Sunk Washers (#W-1)** **8x**

 **J-Clip (#N-13)** **10x**

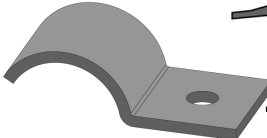
 **1 1/2" x 1 3/4" "D" Clamps (#C-D:6)** **4x**

 **Extension Bracket (#E-B:7)** **1x**

 **Extension Bracket (#E-B:8)** **1x**

#4 Side bolts large bag:

 **1/4"-20 x 3/4" Self Taping Bolt (#B-D:2)** **14x**

 **Counter Sunk Washers (#W-1)** **14x**

RS **If: Rock Slider 's replace** **14x**

 **1/4"-20 x 1 1/4" Self Taping Bolt (#B-D:4)** **14x**

#3 Front Diff Skid Small bag:

 **1/4"-20 x 3/4" Self Taping Bolt (#B-D:2)** **4x**

 **Counter Sunk Washers (#W-1)** **4x**

#1 Rear Skid Small bag:

 **1/4"-20 x 1" Self Taping Bolt (#B-D:3)** **2x**

 **M6- 1.0 x 30mm Flange Bolt (#B-A:7)** **2x**

 **Counter Sunk Washers (#W-1)** **4x**

#6 Standard Front A-Arm large bag:

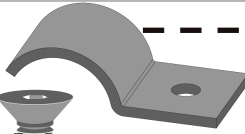
 **1" x 1" "D" Clamps (#C-D:2)** **4x**

 **1/4"-20 x 1" Counter Sunk Bolts (#B-C:1)** **4x**

 **1/4"-20 x 1 1/2" Counter Sunk Bolts (#B-C:3)** **4x**

 **1/4" Gold Washers (#W-3.0)** **8x**

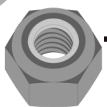
 **1/4"-20 Ny-Lock Nut (#N-2)** **8x**

#7 Standard Rear A-Arm large bag:

 **1 1/2" x 1 1/4" "Box" Clamps (#C-B:2)** **2x**

 **1/4"-20 x 1" Counter Sunk Bolts (#B-C:1)** **2x**

 **1/4"-20 x 2 1/2" Counter Sunk Bolts (#B-C:6)** **6x**

 **1/4" Gold Washers (#W-3.0)** **8x**

 **1/4"-20 Ny-Lock Nut (#N-2)** **8x**

#6 High Clearance Front A-Arm large bag:

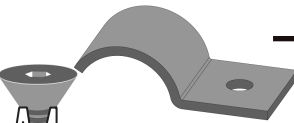
 **1" x 1 1/4" "D" Clamps (#C-D:3)** **10x**

 **1/4"-20 x 1 1/4" Counter Sunk Bolts (#B-C:2)** **10x**

 **1/4" Gold Washers (#W-3.0)** **10x**

 **1/4"-20 Ny-Lock Nut (#N-2)** **10x**