

Contact Us: *FACTORY UTV LLC*

9237 Beatty Drive Sacramento, CA 95826

Phone : (916) 383-2730

E-mail : info@factoryutv.net

Go online: www.Factoryutv.net



U.H.M.W. Skid Plate / Under Armor Package

Ultra. High. Molecular. Weight. polyethylene all terrain skid plate / under armor kit for UTV's

Installation Guide

Can-Am Defender Max (2018)

A-Arm Guards fit: Cab XT and Lone Star models only



Can-Am Defender Max (2018) UHMW Skid Plate Installation

Remove Stock Skid Plate. Carefully Drill Out Riveted Locations.

Use caution while drilling. You will need to re-use mounting holes with self tapping bolts.

(See: **Drilling instructions** below prior to drilling)

#0

Mounting Brackets :

Install brackets with J-clip tips pointing up and inwards, along diagonal frame, note left and right configuration.

Install (1:A) Bolts in stock rivet locations with out washer, in to chassis frame, keeping brackets in place.

(See diagram on pg. 3) Continue with main skid installation after installing brackets.

During skid plate installation, you will need to remove bolt and replace bolt with washers individually to keep brackets in place during installation.



Bracket & J-clip Tip pointing inwards towards UTV

#1

Main Skid Plate :

Install using : (16x) $\frac{1}{4}$ "-20 x $\frac{3}{4}$ " Self Tapping Bolts in main skid: (A) locations.

Loosely mount bolts first, to aid positioning of skid and chassis frame during install.

(1:A) Locations: individually remove mounting bolt, and re-install with washer, keeping bracket in place in (1:A) locations.

Disregard side bolt (A) locations until later steps.

#2

Mid Skid Plate :

Install: (15x) $\frac{1}{4}$ "-20 x $\frac{3}{4}$ " Self Tapping Bolts in center of mid skid: (A) locations.

Align edge. Loosely mount bolts first, to aid positioning of skid and chassis frame during install.

Install: (2x) M6 1.0 x 20mm Self Tapping Bolts through bracket in mid skid: (B) locations.

Install: (2x) $\frac{1}{4}$ "-20 x $\frac{3}{4}$ " Flange Bolts with $\frac{1}{4}$ " Zinc Washers, and $\frac{1}{4}$ "-20 Ny-Lock nuts in mid skid: (<D>) locations.

Disregard side bolt (A) locations until later steps.

#3

Rear Diff. Skid Plate :

* Align edge with main skid. (See: **Drilling instructions** below)

Mark, drill and install: (12x) $\frac{1}{4}$ "-20 x $\frac{3}{4}$ " Self Tapping Bolts in rear diff. skid : (A) locations.



* (Align Edge)

#4

Front Diff. Skid Plate :

Use a mallet to bend metal tab inwards, *(See diagram), Align edge with main skid.

Install: (4x) $\frac{1}{4}$ "-20 x $\frac{3}{4}$ " Flange Bolts and (4x) $\frac{1}{4}$ "-20 Flange nuts in front diff. skid: (A) locations.

Bend Tab Inwards

#5

Side Bolts :

Once skid plates are installed, using skid plate as a template, mark, drill and install:

(20x) $\frac{1}{4}$ "-20 x $\frac{3}{4}$ " Self Tapping Bolts in side main & mid skids : (A) locations.

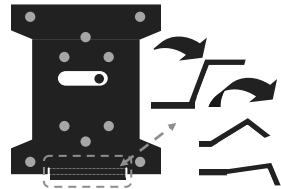

*RS

*If Installing Rock Sliders :

Install: Rock Sliders in-between skid plate and chassis frame using side bolt locations.

Use: (20x) $\frac{1}{4}$ "-20 x $\frac{1}{4}$ " Self Tapping Bolts in side main and mid Skid: (A*) locations, (in lieu of 20x (A) side bolts)



* Drilling Instructions : *

Use a : #N_o7 ($\frac{13}{64}$ ") drill bit,

(one size above the commonly available $\frac{3}{16}$ " bit) Recommended $\frac{1}{4}$ "- 20 Tap *(Optional)

To drill and thread self tapping bolts in to chassis frame.

Finger Thread All Bolts Prior To Fastening Securely With Power Tools.

We strongly recommend the use of a "Thread Locking Compound" when installing any mounting hardware.

(When installation is complete , ensure all bolts are fastened securely.)

Can-Am Defender Max (2018) Instructions

Read :
 Instructions on (Pg. 2)
 Remove stock skid plate,
 *Carefully Drill out rivets
 Re-use mounting holes.
 Tighten bolts when
 secure.

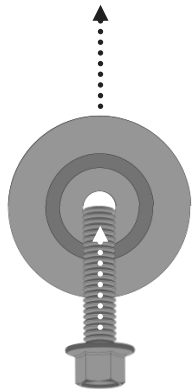
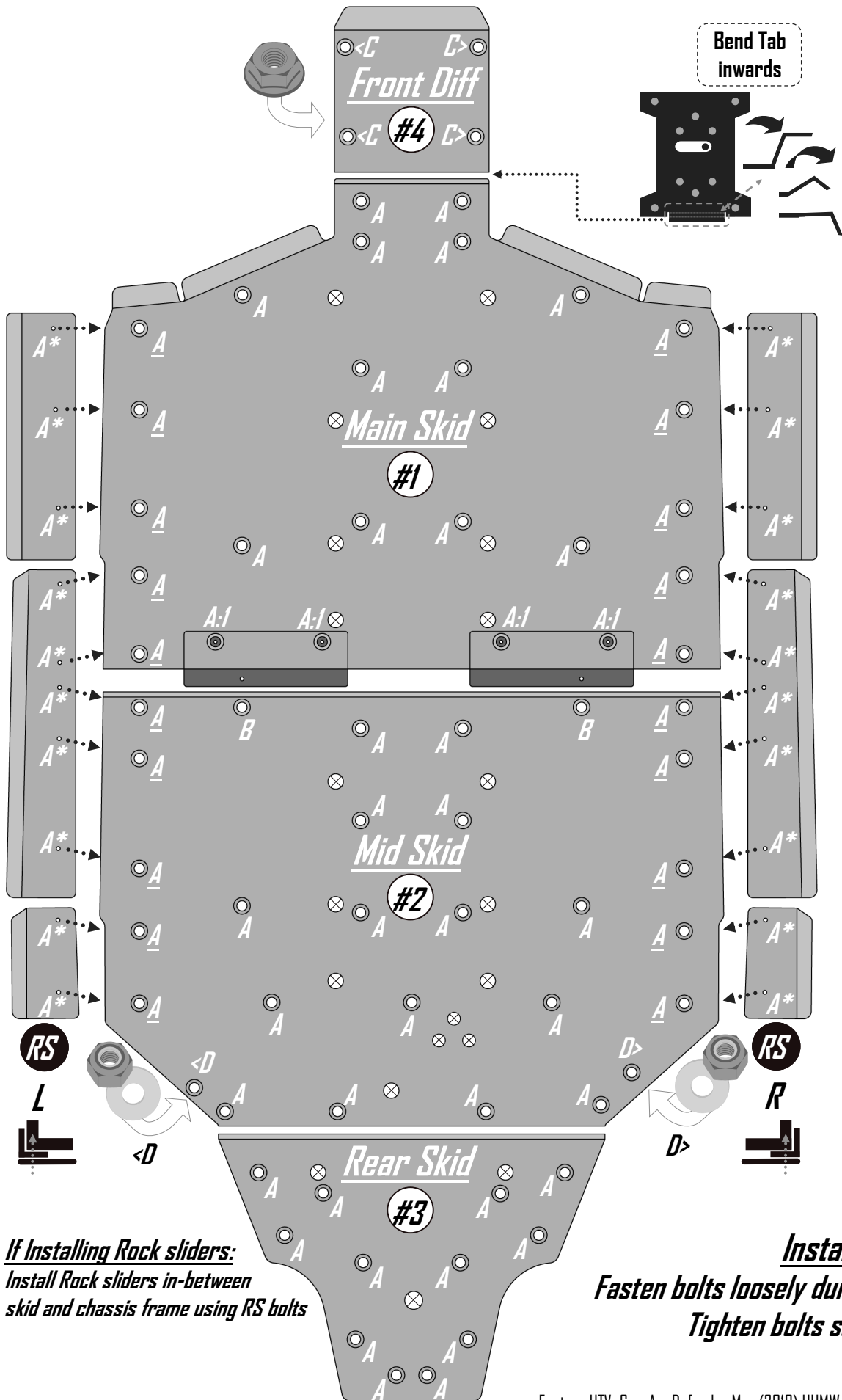

" _ " Locations
 Require Drilling
 " * " Locations
 Use RS hardware
 " < > " Locations
 Use nut/washer

⊗ = Drainage Holes
 Do Not Use For Mounting

If Installing Rock sliders:
 Install Rock sliders in-between
 skid and chassis frame using RS bolts



Install tip:
 Fasten bolts loosely during install for adjustments,
 Tighten bolts securely when done

Can-Am Defender Max (2018) Hardware kit

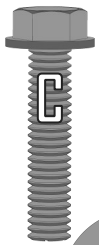
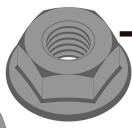
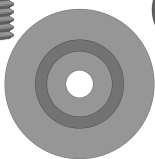
#4 Front Diff Skid small bag:

-  **4x**
1/4" - 20 x 3/4" hex flange bolt zinc (#B-A:2)
-  **4x**
1/4" - 20 Flange Nut (#N-3)
-  **4x**
Counter Sunk Washers (#W-1)

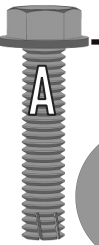

#3 Rear Diff Skid small bag:

-  **12x**
1/4" - 20 x 3/4" Self Tapping Bolt (#B-D:2)
-  **12x**
Counter Sunk Washers (#W-1)

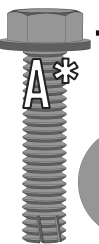
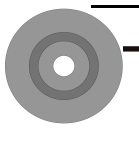

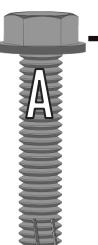

#5 Side bolts small bag:

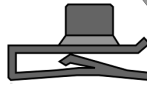
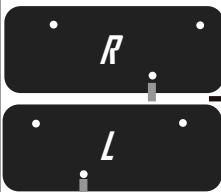
-  **20x**
1/4" - 20 x 3/4" Self Tapping Bolt (#B-D:2)
-  **20x**
Counter Sunk Washers (#W-1)
- RS** *If: Rock Slider's* replace A* **20x**
1/4" - 20 x 1 1/4" Self Taping Bolt (#B-D:4)

#1 Main Skid Large bag:

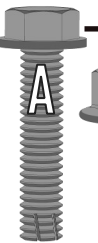
-  **16x**
1/4" - 20 x 3/4" Self Tapping Bolt (#B-D:2)
-  **16x**
Counter Sunk Washers (#W-1)
-  **2x**
J-Clip (installed on Brackets) (#N-13)
-  **2x**
(R & L) Extension Brackets (#E-B:6)

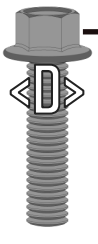
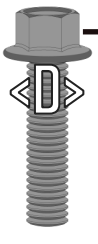
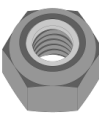
#2 Mid Skid bag:

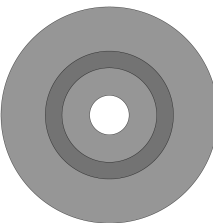
-  **15x**
1/4" - 20 x 3/4" Self Tapping Bolt (#B-D:2)
-  **2x**
1/4" - 20 x 3/4" Self Tapping Bolt (#B-D:2)
-  **2x**
M6 1.0 x 20mm hex flange bolt (#B-A:5)
-  **2x**
1/4" - 20 x 3/4" Flange Bolt (#B-A:2)
-  **2x**
1/4" - 20 Ny-Lock Nut (#N-2)
-  **2x**
1/4" Zinc Washers (#W-4)
-  **19x**
Counter Sunk Washers (#W-1)

Can-Am Defender/ Defender Max (2018)

Factory UTV UHMW A-Arm Guard Instructions

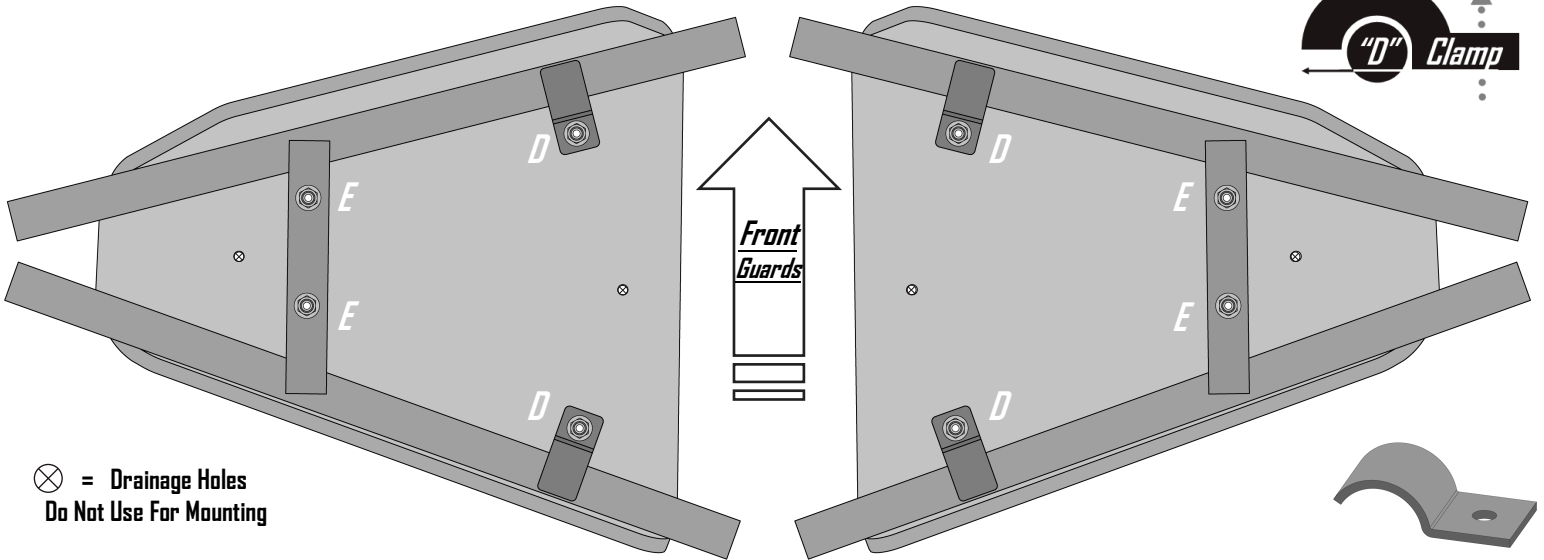

⊗ = Drainage Holes
Do Not Use For Mounting

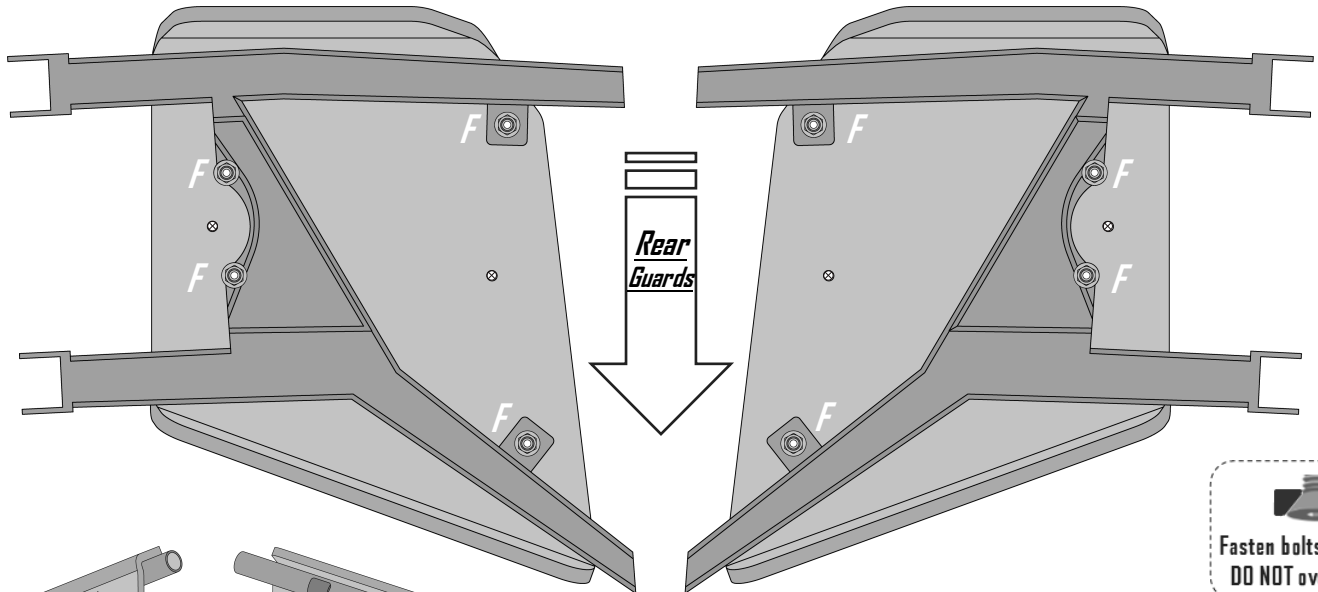

Fasten bolts until flush
DO NOT over tighten

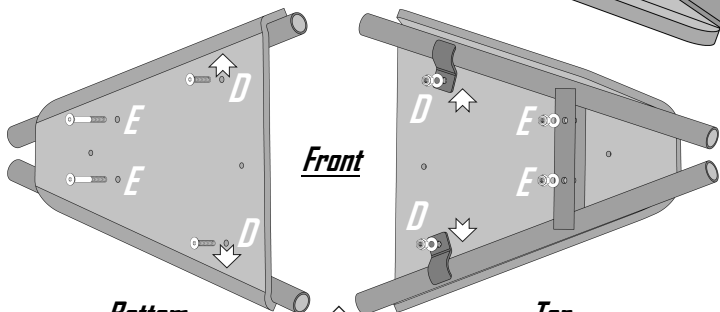

Front

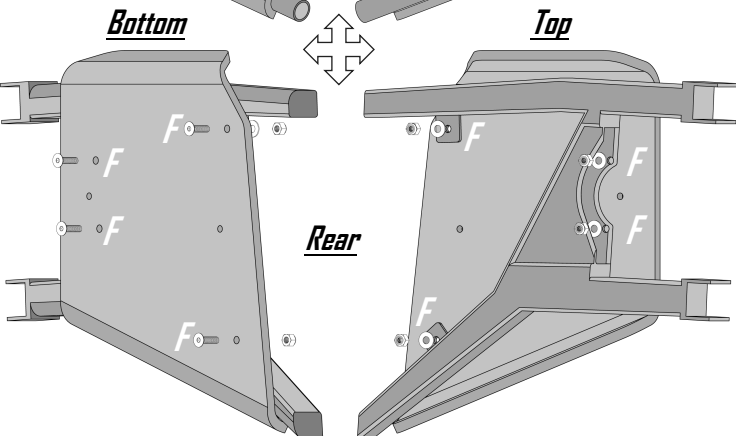

Bottom

Top

Rear

Front A-Arm Guards:

Install "D" Clamps over A-Arm Tubing in (D) locations Use:

(4) 1/4"-20 x 1 1/4" Counter Sunk Bolts, 1/4" Gold Washers, 1/4"-20 NyLock Nuts.

For (E) locations Use:

(4) 1/4"-20 x 2 1/4" Counter Sunk Bolts, 1/4" Gold Washers, 1/4"-20 NyLock Nuts.

Rear A-Arm Guards:

For (F) locations Use:

(8) 1/4"-20 x 1" Counter Sunk Bolts, 1/4" Gold Washers, 1/4"-20 NyLock Nuts.

***Ensure** Clearance For Turn Radius & Vertical Travel Before **Fastening ALL Bolts Securely.**

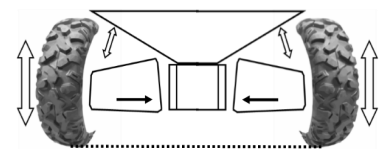
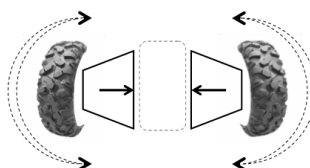

Can-Am Defender/ Defender max (2018) A-Arm Hardware

For Standard OEM A-Arm Guard Hardware:

#1 Front A-Arm Guards small bag:

- 4x 1"x 1"- "D" Clamps (#C-D:2)
- 4x 1/4"-20 x 2 1/4" Counter Sunk Bolts (#B-C:5)
- 4x 1/4"-20 x 1 1/4" Counter Sunk Bolts (#B-C:2)
- 8x 1/4" Gold Washers (#W-3)
- 8x 1/4"-20 Ny-Lock Nut (#N-2)

#2 Rear A-Arm Guards small bag:

- 8x 1/4"-20 x 1" Counter Sunk Bolts (#B-C:1)
- 8x 1/4" Gold Washers (#W-3)
- 8x 1/4"-20 Ny-Lock Nut (#N-2)

If Installing CabXT/Lonestar Guards :

Install in a similar fashion to standard A-Arm guards.
 Use "D" clamps with short bolts over a-arm tubing in inner locations.
 Use the longer bolts through the frame at the ends of the A-Arms.
 Rear arms: hold guard in place on A-arm, place bolts through guard.
 Fasten "D" clamp over a-arm tubing in the arrow directions below.

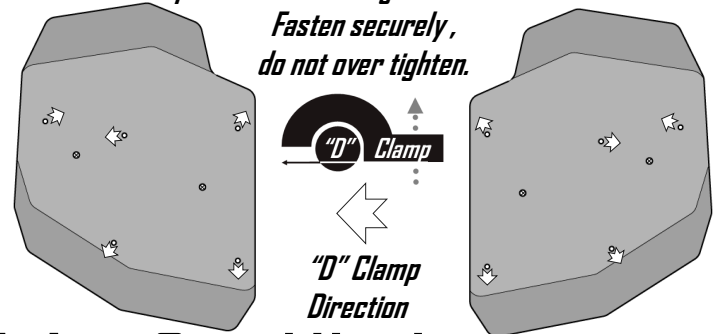
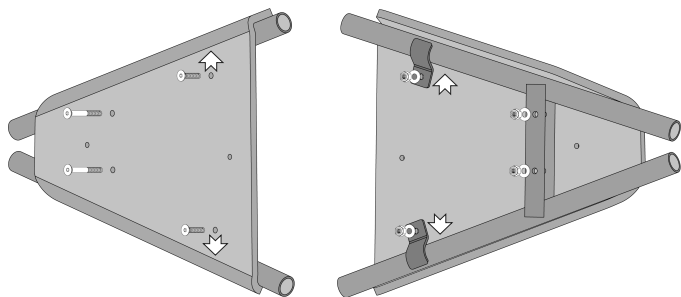

For CabXT/Lonestar OEM A-Arm Guard Hardware:

#1 Front A-Arm Guards small bag:

- 4x 1"x 1"- "D" Clamps (#C-D:2)
- 4x 1/4"-20 x 2" Counter Sunk Bolts (#B-C:4)
- 4x 1/4"-20 x 1 1/4" Counter Sunk Bolts (#B-C:2)
- 8x 1/4" Gold Washers (#W-3)
- 8x 1/4"-20 Ny-Lock Nut (#N-2)

#2 Rear A-Arm Guards small bag:

- 10x 1"x 1 1/2"- "D" Clamps (#C-D:7)
- 10x 1/4"-20 x 1 1/4" Counter Sunk Bolts (#B-C:2)
- 10x 1/4" Gold Washers (#W-3)
- 10x 1/4"-20 Ny-Lock Nut (#N-2)