

Contact Us: *FACTORY UTV LLC*

9237 Beatty Drive Sacramento, CA 95826

Phone : (916) 383-2730

E-mail : info@factoryutv.net

Go online: www.Factoryutv.net



FACTORY UTV

U.H.M.W. Skid Plate / Under Armor Package

Ultra. High. Molecular. Weight. polyethylene all terrain skid plate / under armor kit for UTV's

Installation Guide (Ultimate package)

Polaris

RZR XP 4 1000 (2014-2016+)



Polaris RZR XP 4 1000 (2014-16+) Instructions

Remove stock skid plate and re-use stock hardware as needed in all (A) locations.
May need the use of a car jack to aid during install, Skid's will form to vehicle during installation.

#0

Chassis Frame Mounts:

Install (2x) angle brackets using 2x of the stock self tapping bolts to thread in to chassis frame (A) locations,
Install Cross member : (1x) stock bolt in (A) location, & (2x) "D" clamps W/ (2x) M6-1.0 x 20mm Flange Bolt in (E) locations

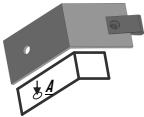

#1_{a-b}

Main and Mid Skid Plates :

Install mid skid 1_(a) before main skid 1_(b), align edge. Use: (16x) Stock Bolts in Main Skid: (A) locations.

Install: (4x) M6-1.0 x 25mm Flange Bolts with "D" Clamps in Main Skid : (D) locations.

Defer side (B) locations Until Step (#4)



#2

Rear Skid Plate :

Align edge with main skid plate

Install: (7x) or (9x) ¼"-20 x 1" Self Tapping Bolts, depending on the year of the vehicle (2014-2016)

With (2x) UHMW Spacers in Rear skid: (B) locations. (spacers not needed for 2017+ models)

Mount forward bolts first to aid in positioning of rear spacers between skid and chassis frame.



#3

Diff. Skid Plate :

(See Drilling Instructions Below) Align edge with Main Skid. Mark, drill and install: (4x) ¼"-20 x ¾" Self Tapping Bolts in Diff. Skid : (C) locations.



*(Align Edge)

#4

Side Mounts (B):

(See Drilling Instructions Below)

Align, mark, drill, and Install: (16x) ¼"-20 x 1" Self Tapping Bolts in Main Skid : (B) locations.



RS

If Rock Sliders :

Use: (16x) ¼"-20 x 1 ¼" Self Tapping Bolts, "RS" bolts In main skid : (B) locations.

In lieu of side bolts (¼"-20 x 1" Self Tapping Bolts) Place in-between skid and chassis Frame.



T:1

Trailing Arm Guards : (T:1)

Install : (3x) ¼" x 20 x 3" Hex Bolts W/ (6x) ¼" Zinc Washers, and (3x) ¼" x 20 Ny-Lock Nuts

In : (T:1) locations. (on Each Trailing Arm Guard).

A:1

A-Arm Guards (A:1) (A:2)

Install : (3x) "D" clamps over A-Arm tubing W/ (3x) ¼"-20 x 1 ¼" Counter Sunk Bolts,

(3x) ¼" Gold Washers, and (3x) ¼"-20 Ny-Lock Nuts in: (A:1) locations.

Install : (2x) ¼"-20 x 1 ½" Counter Sunk Bolts, W/ (2x) ¼" Gold Washers, and (2x) ¼"-20 Ny-Lock Nuts through stock

mounting holes at apex of A-Arm in: (A:2) locations. (on Each A-Arm Guard)

* **Ensure** Clearance For Turn Radius & Vertical Travel

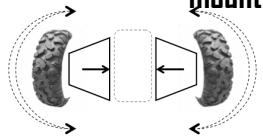

Before Fastening ALL Bolts Securely

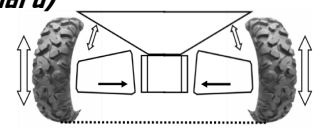

* Drilling Instructions : *

Use a : #N_o7 (13/64th) drill bit,

(one size above the commonly available 3/16th bit) Recommended ¼"- 20 Tap *(Optional)

To drill and thread self tapping bolts in to chassis frame.

Finger Thread All Bolts Prior To Fastening Securely With Power Tools.

We strongly recommend the use of a "Thread Locking Compound" when installing any mounting hardware.

(When installation is complete , ensure all bolts are fastened securely.)

Polaris RZR XP 4 1000

(2014-16+)

Install brackets.
Re-use stock hardware.
Tighten skid bolts loosely for install adjustments, fasten securely when complete.

Fasten bolts until flush
DO NOT over tighten

"D" Clamp

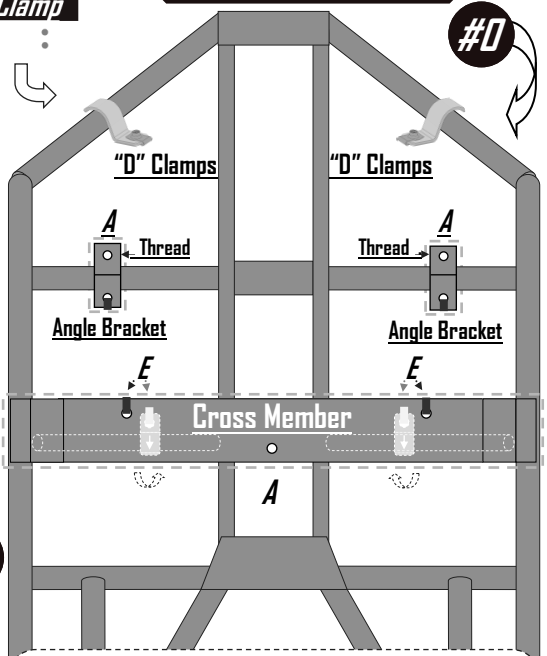
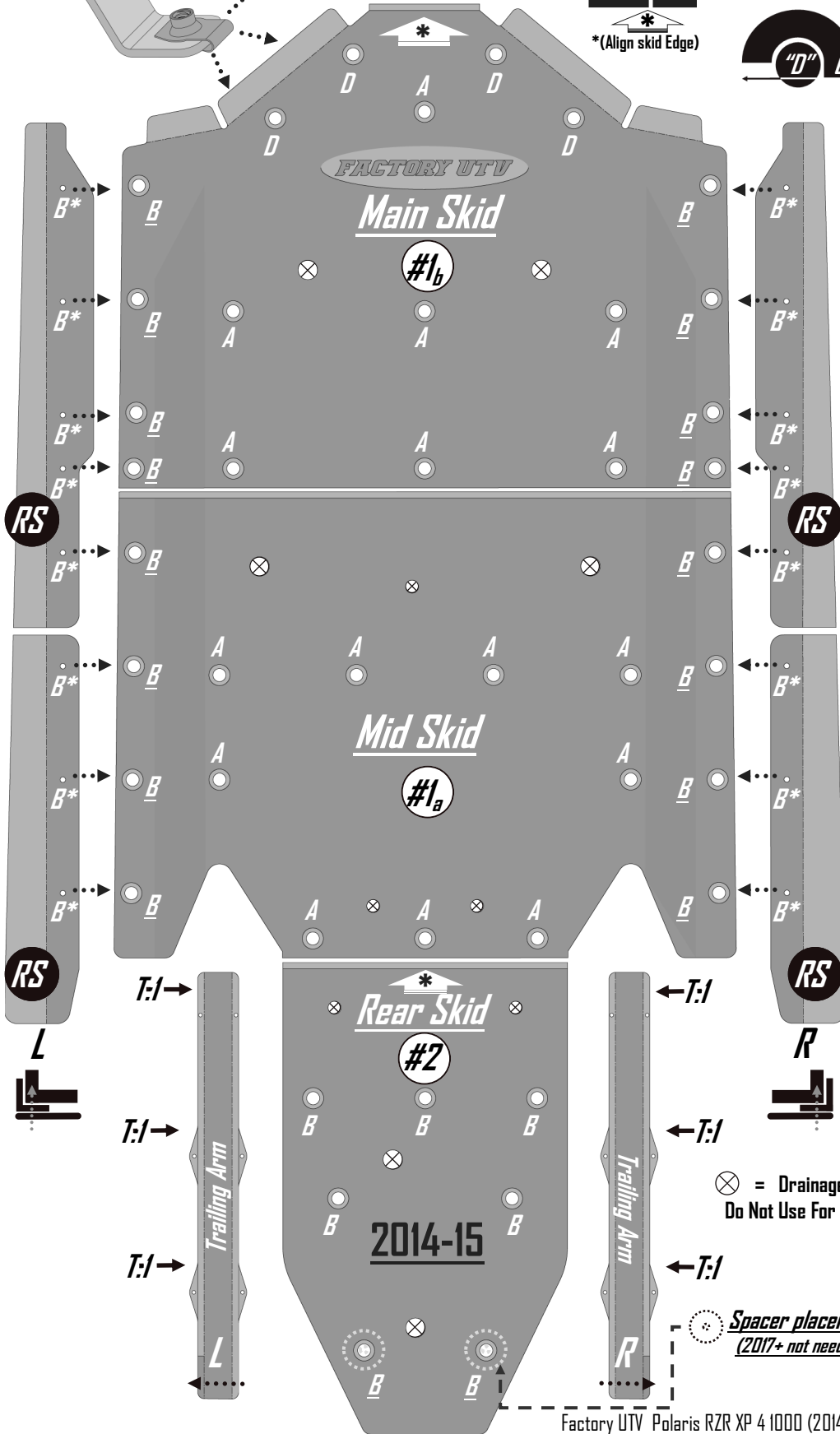
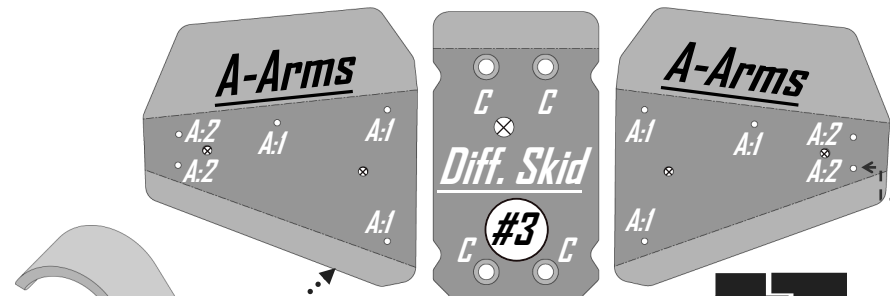

Bolt D clamps on to Cross Member, and mount on to chassis frame

Angle Bracket
Thread stock self tapping "A" bolts in to un-threaded holes in frame locations.

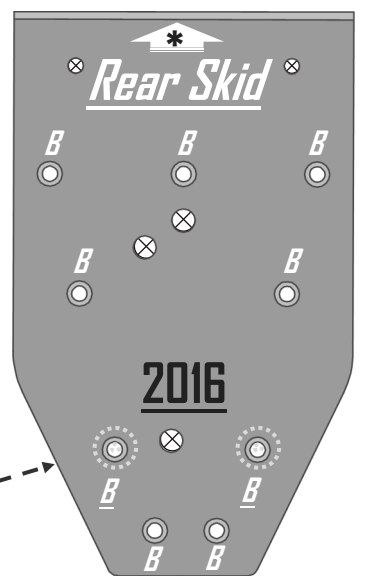

Polaris RZR XP 4 1000 (2014-16+) Hardware kit

Skid Plate Hardware

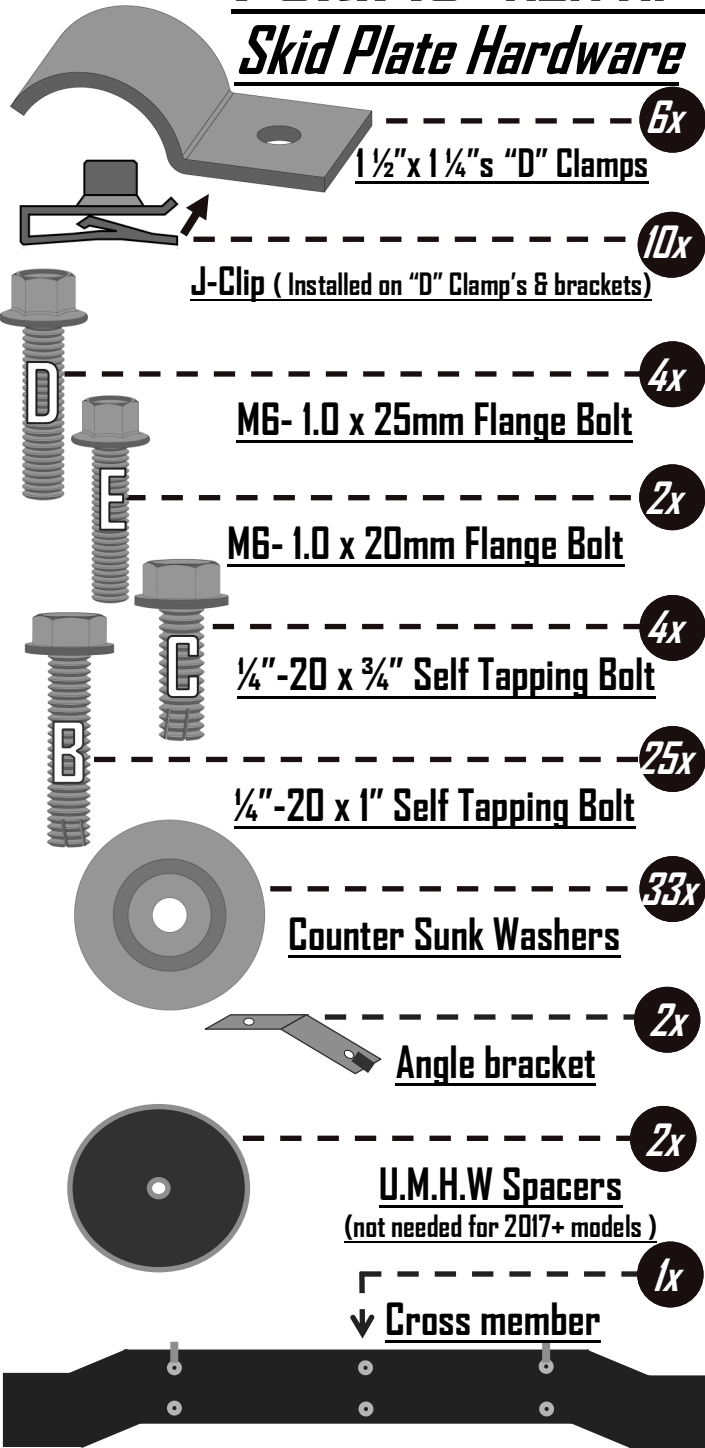

A-Arm Hardware

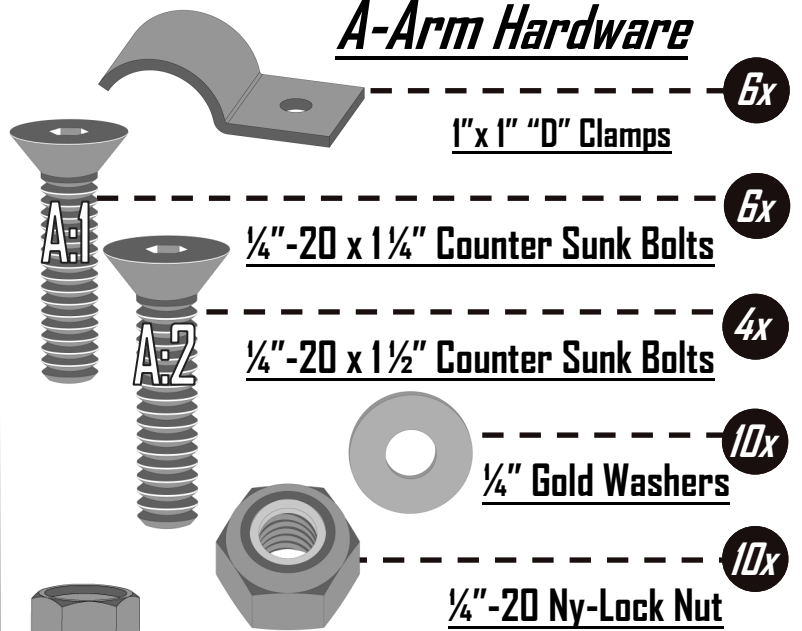

Trailing-Arm Hardware



Rock Slider Hardware



**(All bolt lengths here are sized to scale.)*

* Drilling Instructions : *

Use a : #Nº7 (13/64th) drill bit,

(One size above the commonly available 3/16th bit) Recommended use with a ¼"-20 Tap *(Optional)

To drill and thread self tapping bolts in to chassis frame.

Finger Thread All Bolts Prior To Fastening Securely With Power Tools.

We strongly recommend the use of a "Thread Locking Compound" when installing any mounting hardware.

(When installation is complete, ensure all bolts are fastened securely.)