

Contact Us: *FACTORY UTV LLC*

9237 Beatty Drive Sacramento, CA 95826

Phone : (916) 383-2730

E-mail : info@factoryutv.net

Go online: www.Factoryutv.net



U.H.M.W. Skid Plate / Under Armor Package

Ultra. High. Molecular. Weight. polyethylene all terrain skid plate / under armor kit for UTV's

Installation Guide (Ultimate Package)

Yamaha

***Wolverine RMAX 2* (2020 - 2021+)**



Yamaha Wolverine RMAX 2 (2020 - 2021+) Instructions

#1

J-Clip Mounting Locations :

Install J-clips : Slide J-clip in to rectangular openings with threaded tip pointing upwards, towards the vehicle.
Drill holes slightly larger with a 3/8" Drill bit, Slide j-clip in to the center of the mounting hole and adjust until clip fastens securely.
Ensure J-clip's are in the right direction as they can be difficult to remove and re install.

If your holes in the A locations don't quite align during skid plate installation, check J-clip placement.

Most locations only install in one direction, for the A locations with the dotted rectangle. (Reference diagram to the right, or on page 3.)



#2

Rear Diff. Skid Plate :

Mounting hole →



With J-clips installed, Install: (4x) M6- 1.0 x 20mm Flange Bolts in: *Rear Skid: (A) Locations.*

Fasten bolts and washers loosely to allow for adjustments with main skid plate.

#3

Main Skid Plate :

Align edge with rear diff skid plate, use: (16x) M6- 1.0 x 20mm Flange Bolts in: *Main Skid: (A) Locations.*

Disregard Main Skid: (B) Location until final step.

Fasten bolts and washers loosely to allow for adjustments with front and rear skid plate, adjust skid plates as needed.



#4

Front Diff. Skid Plate :

Install front diff skid plate with: (2x) M6- 1.0 x 20mm Flange Bolts fastened loosely in: *Front Diff Skid: (A) Locations.*

Place *S/* spacer between front diff skid plate and stock plastics with (2x) M6- 1.0 x 30mm Flange Bolts in: *Front Diff Skid: (C) Locations.*

Fasten (A) and (C) bolts loosely, adjust edge to align with Main and Rear Diff skid plate.

Once front, main, rear skid plates are aligned, fasten All (A) and (C) bolts securely.

Disregard Front Diff Skid: (C), (E) and (B) Locations until final step.



#5

Side Skid Plates :

With J-clips installed, Loosely install : (14x) M6- 1.0 x 20mm Flange Bolts in: *Side Skid: (A) Locations.*

With main skid in place, adjust side skid plates to meet up flush with edges of main skid plate, then fasten all (A) locations securely.

*if installing with Rocksliders, see RS steps below before fastening bolts in all locations.

Disregard Side Skid: (B*) Locations until final step.

RS

*If Rock Sliders :

If installing with *Rock Sliders*, Install in-between skid plate and chassis frame. Use provided longer hardware in lieu of side bolts,

Install (6x) M6- 1.0 x 35mm Flange Bolts in lieu of (6x) M6- 1.0 x 20mm Flange Bolts in: *Side Skid: (A*) Locations.*

Install (6x) 1/4"-20 x 1 1/4" Self Taping Bolts in lieu of (6x) 1/4"-20 x 3/4" Self Taping Bolts in: *Side Skid: (B*) Locations.*

RS



#6

Final Step :

(See Drilling Instructions Below) With all skid plates aligned and adjusted in place as needed,

Mark, drill and install: (10x) 1/4"-20 x 3/4" Self Taping Bolts in: *Main, Front Diff and Side Skid: (B) Locations.*

For side (B*) locations in nerf bars, ensure to drill in to center of tubing. *(Use of a 1/4"-20 Tap may assist in threading these locations.)

Mark, drill and install: (2x) 1/4"-20 x 1" Self Taping Bolts in: *Front Diff Skid: (E) Locations.*

Once all skid plates are mounted in place, ensure all bolts are fastened securely.

* Drilling Instructions : *

For J-clip "A" locations, use a 3/8" Drill bit to widen pre existing holes If needed .

For " B " locations use : #Nø7 (13/64th) drill bit,

(one size above the commonly available 3/16th bit) Recommended 1/4" - 20 Tap *(Optional).

To drill and thread self tapping bolts in to chassis frame.

Finger Thread All Bolts Prior To Fastening Securely With Power Tools.

We strongly recommend the use of a "Thread Locking Compound" when installing any mounting hardware.

(When installation is complete , ensure all bolts are fastened securely.)



13/64th
3/8th

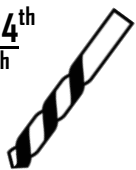

Yamaha Wolverine RMAX 2 (2020 - 2021+)

First:
Install J-clips
in to rectangle holes,
with threaded tip pointing
upwards towards vehicle!

#1

SI - Spacer
Install (SI) Spacer in-between
Front Diff Skid plate and stock plastic guard.
Install Diff Skid plate loosely for adjustment,
Secure bolts once skid is in place.



Ensure J-clips are installed in the correct holes in these locations.
Incorrect mounting will result in misaligned holes during skid plate install.

A

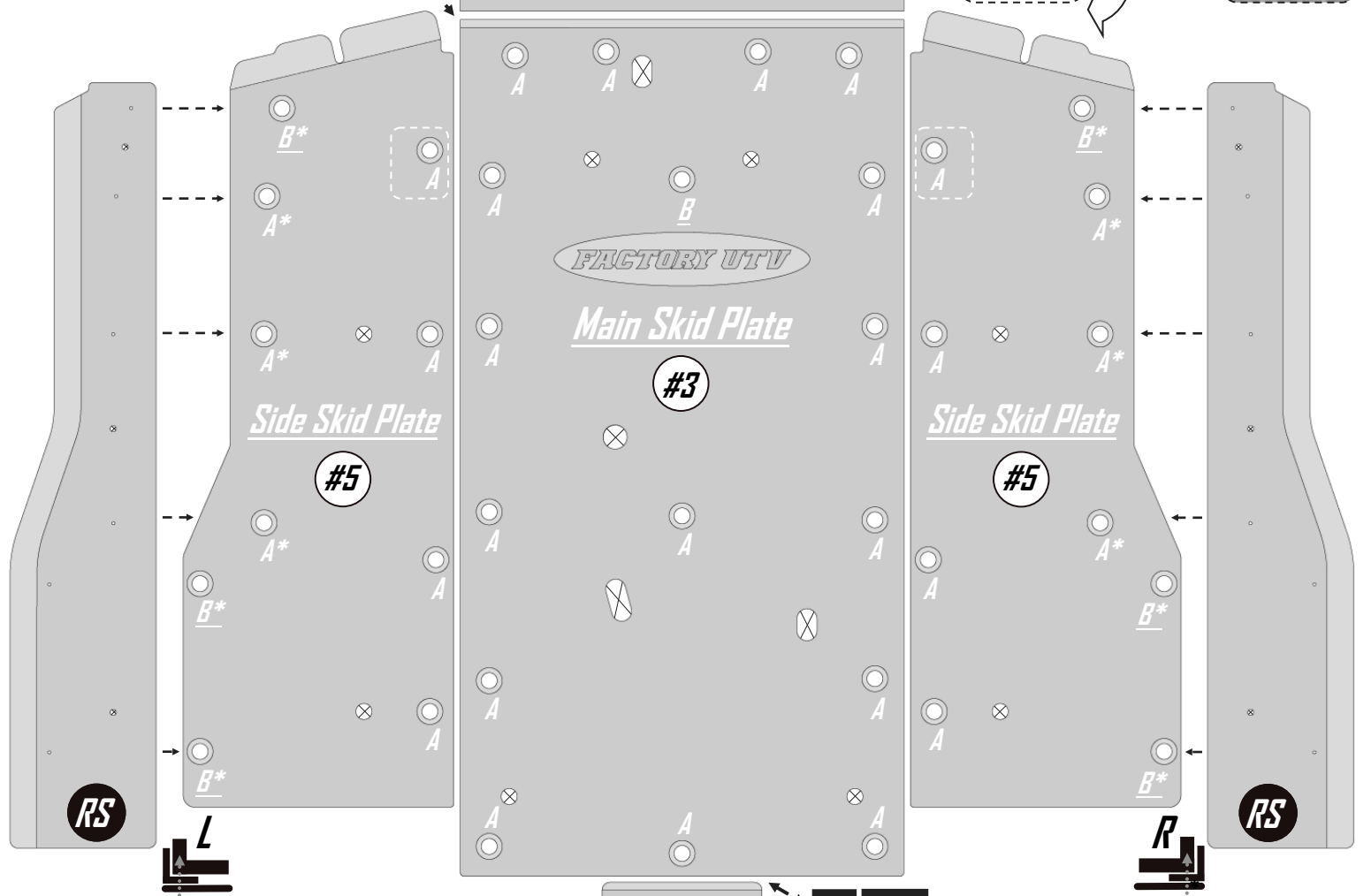

***If installing Rocksliders,**
Place Rocksliders in-between skid plate and chassis frame,
use provided longer "RS" hardware. For A* and B* locations

#2
Rear Diff Skid Plate

*(Align Edge)

Installation Requires:
Drill Bits, (1/4" - 20) Tap and clamps





13/64th
3/8th

Installation may require the use of
Clamps or a Car jack to aid with install.

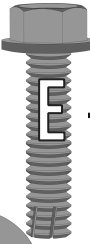

⊗ = Drainage Holes
Do Not Use For Mounting

Yamaha Wolverine RMAX 2 (2020-2021+) Skid Plate Hardware

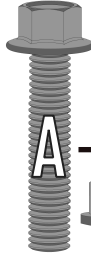
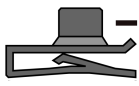

#4 Front Diff. Small Bag:

-  **2x**
- M6- 1.0 x 30mm Flange Bolt (#B-A:7)**
-  **2x**
- M6- 1.0 x 20mm Flange Bolt (#B-A:5)**
-  **3x**
-  **2x**
- 1/4"-20 x 3/4" Self Taping Bolt (#B-D:2)**
- 1/4"-20 x 1" Self Taping Bolt (#B-D:3)**
-  **9x**
- Counter Sunk Washers (#W-1)**

#3 Main Skid Large Bag:



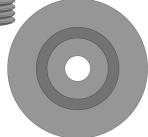

-  **15x**
-  **J-clip (#N-14)**
-  **15x**
- M6- 1.0 x 20mm Flange Bolt (#B-A:5)**
- 1x**
- 1/4"-20 x 3/4" Self Taping Bolt (#B-D:2)**
-  **17x**
- Counter Sunk Washers (#W-1)**

#2 Rear Diff. Small Bag:

-  **4x**
-  **J-clip (#N-14)**
- 4x**
- M6- 1.0 x 20mm Flange Bolt (#B-A:5)**
-  **4x**
- Counter Sunk Washers (#W-1)**



 **1x S1 Spacer**

#5 Side Skids Large Bag:

-  **14x**
- J-clip (#N-14)**
-  **14x**
- M6- 1.0 x 20mm Flange Bolt (#B-A:5)**
-  **6x**
- 1/4"-20 x 3/4" Self Taping Bolt (#B-D:2)**
-  **20x**
- Counter Sunk Washers (#W-1)**

****Use Rockslider hardware in lieu of: side skid A* and B* bolts***

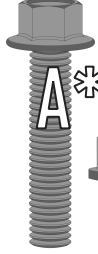
RS * If Rock Sliders Bag:

-  **6x**
- M6- 1.0 x 35 mm Flange Bolt (#B-A:8)**
-  **6x**
- 1/4"-20 x 1 1/4" Self Taping Bolt (#B-D:4)**

Yamaha Wolverine RMAX 2 (2020 - 2021+)

UHMW Front A-arm Guard Installation Guide.

Installation Requires:
 10mm socket.
 Use of Thread locking compound is strongly recommended.

 = 10mm

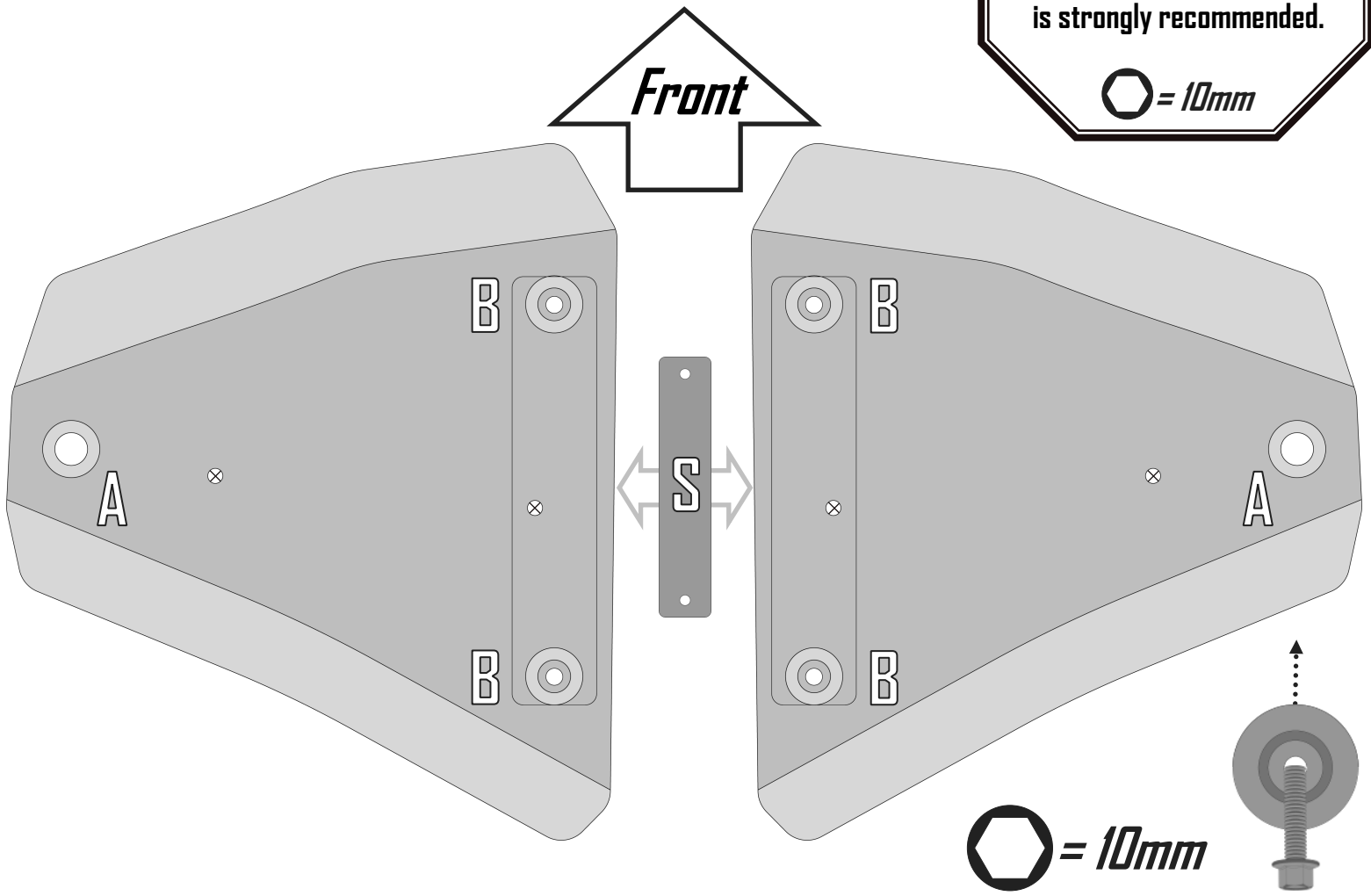

 = 10mm

Front A-arm Guard Installation :

First:





Hold A-arm guard in place,
 Install : (2x) M6- 1.0 x 20mm Flange Bolts
 in (A) locations.

Second:

Slide (S) Spacers in-between A-arm and A-arm Guards,
 Install : (4x) M6- 1.0 x 40mm Flange Bolts in (B) locations
 to fasten A-arm guards and spacers.

Fasten securely before use.

#1 Front A-arm Guard Hardware

-  **2x**
M6- 1.0 x 20mm Flange Bolt (#B-A:5)
-  **4x**
M6- 1.0 x 40mm Flange Bolt (#B-A:9)
-  **6x**
Counter Sunk Washers (#W-1)
-  **2x**
1/2" UHMW Spacer (#S-C:16)

⊗ = Drainage Holes
 Do Not Use For Mounting

Yamaha Wolverine RMAX 2 (2020 - 2021+)

UHMW Rear A-arm Guard Installation Guide.

Installation Requires:
 10mm socket.
 Use of Thread locking compound is strongly recommended.

 = 10mm

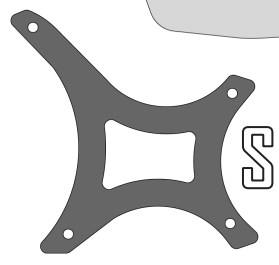
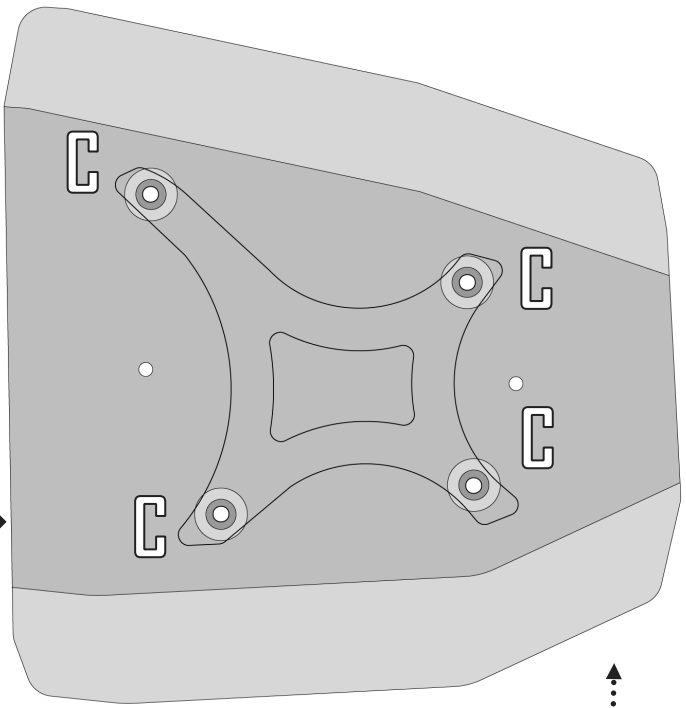
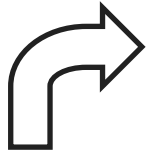
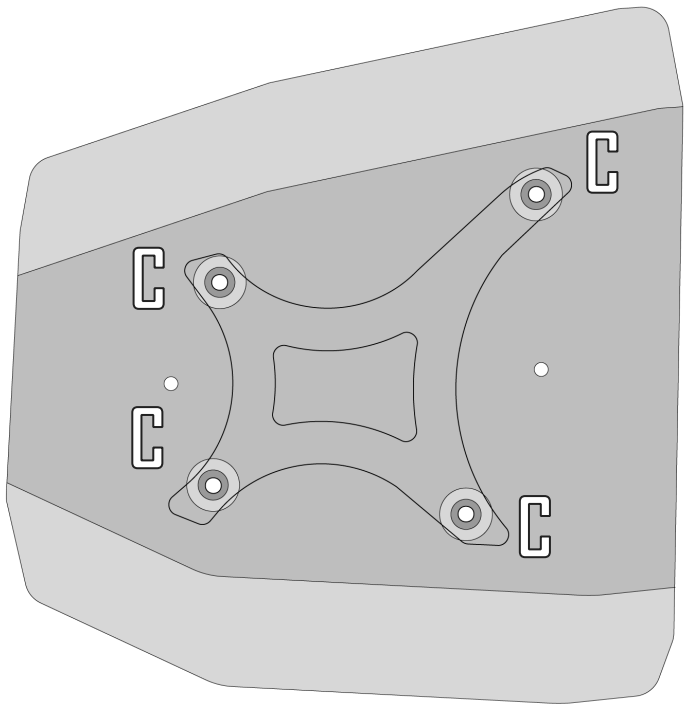
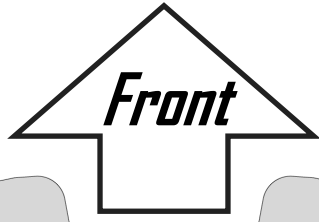

 = 10mm



Rear A-arm Guard Installation :

First:

Align Spacer and hold Rear A-arm guard in place,

Second:

Install : (4x) **M6- 1.0 x 25mm Flange Bolts** in (C) locations.
 Fasten Loosely for adjustments, and tighten when complete.

Fasten all bolts securely before use, do not over tighten.
Use of thread locker recommended.

#2 Rear A-arm Guard Hardware

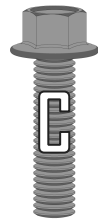

8x

M6- 1.0 x 25mm Flange Bolt (#B-A:6)



8x

Counter Sunk Washers (#W-1)

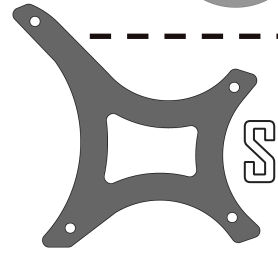

2x

1/2" UHMW Spacer (#S-C:16)

⊗ = Drainage Holes
 Do Not Use For Mounting