

**Contact Us: *FACTORY UTV LLC***

9237 Beatty Drive Sacramento, CA 95826

Phone : (916) 383-2730

E-mail : [info@factoryutv.net](mailto:info@factoryutv.net)

Go online: [www.Factoryutv.net](http://www.Factoryutv.net)



## **U.H.M.W. Skid Plate / Under Armor Package**

*Ultra. High. Molecular. Weight. polyethylene all terrain skid plate / under armor kit for UTV's*

### **Installation Guide (Ultimate Package)**

# **Polaris**

## **RZR XP Turbo S (2018) (2019 - 2020+)**



# Polaris RZR XP Turbo S (2018) (2019-2020+) Instructions

Remove stock skid plate and re-use stock hardware as needed in all ( A ) locations.  $\frac{1}{4}$ "-20 Tap is recommended

#1

## Main Skid Plate :

Install Mounting Bracket first, Install with J-clip tips pointing up towards vehicle, Align edge with front metal plate. Mark, drill and install: (2x)  $\frac{1}{4}$ "-20 x  $\frac{3}{4}$ " Self Tapping Bolts in: ( C ) locations.  
Install Main Skid Plate using : (10x) Stock Bolts in Main Skid: ( A ) locations,  
Install: (2x) M6-1.0 x 25mm Flange Bolts with (2x) "D" Clamps in Main Skid: ( D ) locations.  
Install: (2x) M6-1.0 x 25mm Flange Bolts in Mounting Bracket Main Skid: ( D ) locations.



#2

## Rear Skid Plate :

Align edge with main skid plate Install: (6x)  $\frac{1}{4}$ "-20 x 1" Self Tapping Bolts in Rear skid: ( B ) locations.  
Install: (2x)  $\frac{1}{4}$ "-20 x 1  $\frac{1}{2}$ " Self Tapping Bolts with (2x) Nylon Spacers in Rear skid: ( E ) locations.  
(Mount forward bolts first, to aid positioning of rear spacers between skid and chassis frame. Do not over tighten)

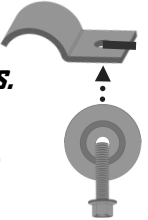

#3

## Front Diff. Skid Plate :

\*(See Drilling Instructions Below)\* Align edge with Main Skid.  
Mark, drill and install: install: (2x)  $\frac{1}{4}$ "-20 x  $\frac{1}{2}$ " Self Tapping Bolts in Diff. Skid: ( F ) locations.  
install: (2x)  $\frac{1}{4}$ "-20 x  $\frac{3}{4}$ " Self Tapping Bolts in Diff. Skid: ( C ) locations.  
install: (2x)  $\frac{1}{4}$ "-20 x 1" Self Tapping Bolts in Diff. Skid: ( B ) locations.  
Double Wall Plating on front diff, in first two ( B ) locations:



Drill  $\frac{5}{16}$ " "larger" clearance holes in first layer, then drill and/or tap smaller hole in backing layer, for use with self tapping bolts.

#4

## Side Mounts ( B ) :

\*(See Drilling Instructions Below)\*  
Align, mark, drill, and Install: (8x)  $\frac{1}{4}$ "-20 x 1" Self Tapping Bolts in Main Skid : ( B ) locations.



RS

## If Rock Sliders :

Use: (8x)  $\frac{1}{4}$ "-20 x 1  $\frac{1}{4}$ " Self Tapping Bolts, "RS" bolts In main skid : ( B ) locations.  
In lieu of side bolts (  $\frac{1}{4}$ "-20 x 1" Self Tapping Bolts ) Place in-between skid and chassis Frame.



T:1

## Trailing Arm Guards : ( T:1 )

Install : (5x)  $\frac{1}{4}$ "x 20 x 3" Hex Bolts W/ (10x)  $\frac{1}{4}$ " Zinc Washers, and (5x)  $\frac{1}{4}$ "x 20 Ny-Lock Nuts  
In : ( T ) locations. (Through Each Trailing Arm Guard).

A:1

## A-Arm Guards (A:1)

Install: (5x) 1" x 1  $\frac{3}{8}$ " "D" Clamps over A-Arm tubing,  
W/ (5x)  $\frac{1}{4}$ "-20 x 1  $\frac{1}{4}$ " Counter Sunk Bolts, (5x)  $\frac{1}{4}$ " Gold Washers, and (5x)  $\frac{1}{4}$ "-20 Ny-Lock Nuts For Each A-Arm in: (A:1) locations.  
Install bolts loosely during install for adjustment, Fasten bolt head flush and securely when complete, do not over tighten.

2018 - Same install method, different hardware. (See Pg 5)

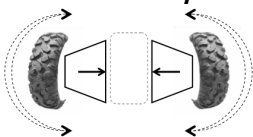

\* Ensure Clearance For Turn Radius & Vertical Travel

## \* Drilling Instructions : \*

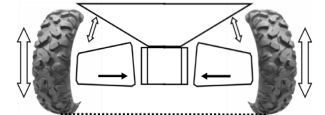

Use a : #No7 (  $\frac{13}{64}$ " ) drill bit,

( one size above the commonly available  $\frac{3}{16}$ " bit ) We recommend (  $\frac{1}{4}$ "- 20 ) Tap for drilled locations.

To drill and thread self tapping bolts in to chassis frame.

Finger Thread All Bolts Prior To Fastening Securely With Power Tools.



We strongly recommend the use of a "Thread Locking Compound" when installing any mounting hardware.

( When installation is complete , ensure all bolts are fastened securely.)

# Polaris RZR XP Turbo S (2018) (2019-2020+)

**Read :**  
 Instructions on pg.#2  
 Remove stock skid plate,  
 reuse hardware as needed.  
 Skid plate will form to fit.  
 See drilling instructions  
 prior to drilling.

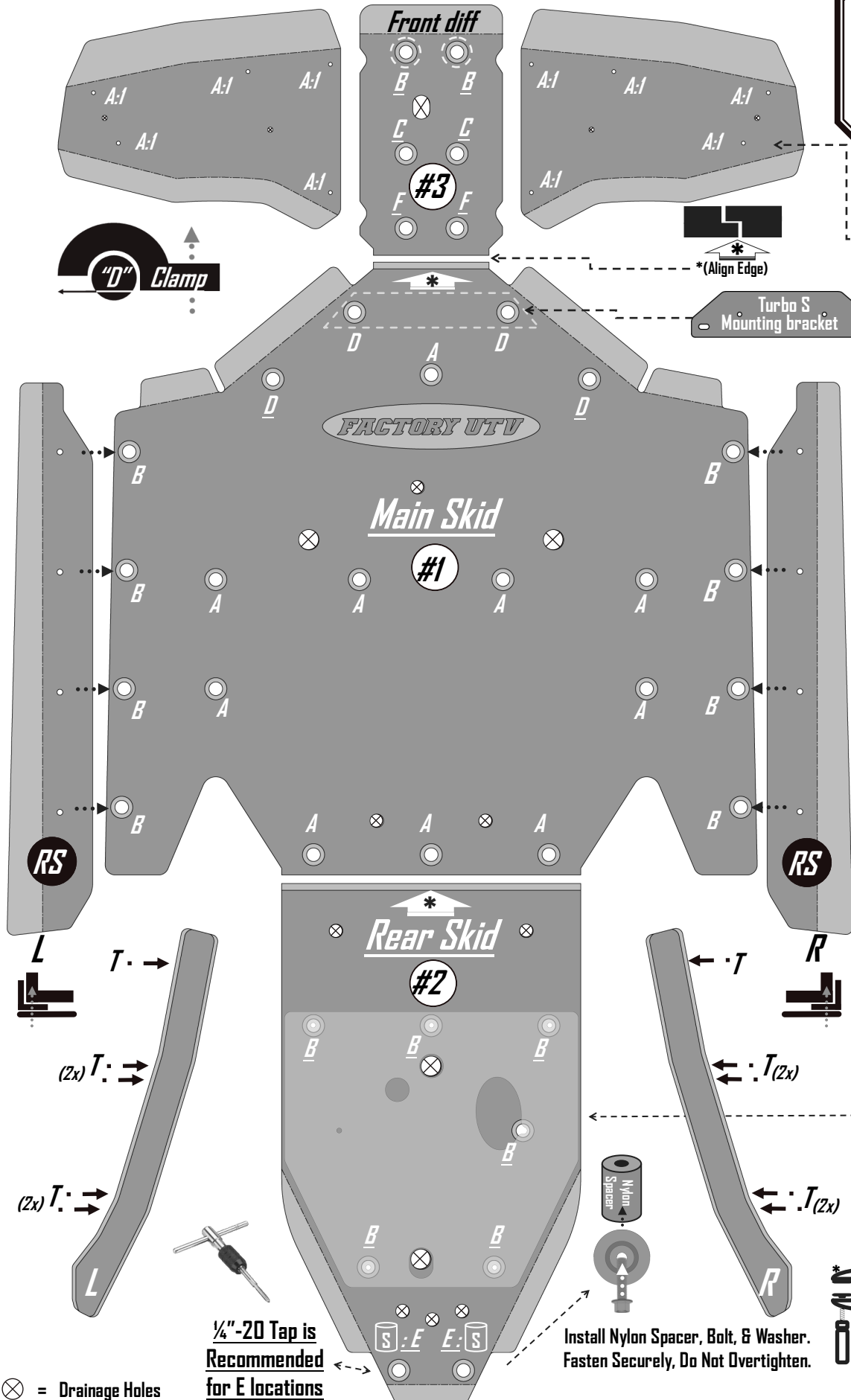

Fasten bolts until flush  
 DO NOT over tighten

**Front Diff Double Wall Plating:**  
 In Front (2x) B Locations only, carefully  
 drill  $\frac{5}{16}$ " clearance holes in first layer,  
 drill and/or tap 13/64th" mounting hole  
 in backing plate for self tapping bolts.

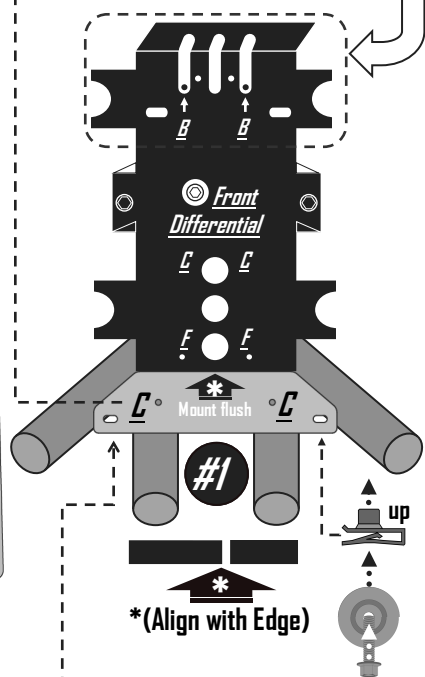

## Mounting Bracket

## If: X Brace

install in-between  
 skid and chassis frame

**\* Trailing arm guard Install Tip:**  
 installation may require the use  
 of clamps to help with  
 fitment and keeping guards in place.  
 Squeeze top of guard to aid with bolts,  
 re-tighten as necessary.

**1/4"-20 Tap is Recommended for E locations**

Install Nylon Spacer, Bolt, & Washer.  
 Fasten Securely, Do Not Overtighten.

⊗ = Drainage Holes  
 Do Not Use For Mounting

# Polaris RZR XP Turbo S

(2018) (2019-2020+) Hardware

## Rear Skid small bag:

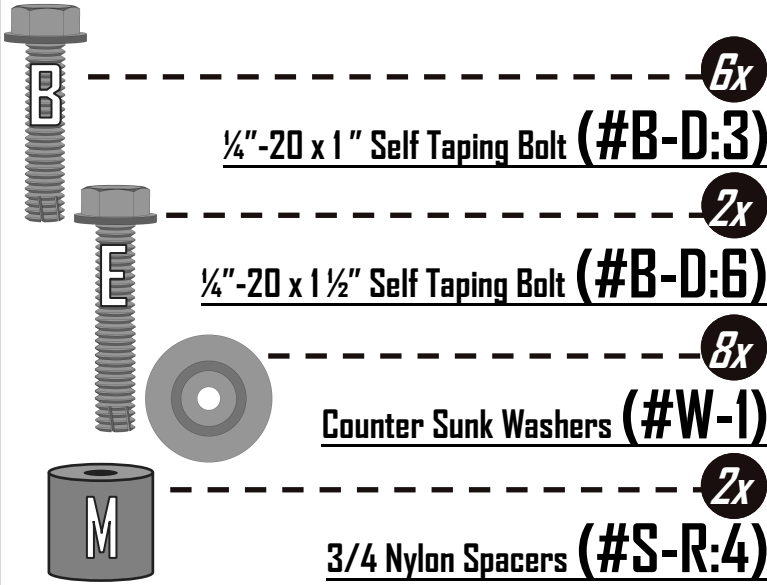

## Front Diff Skid small bag:

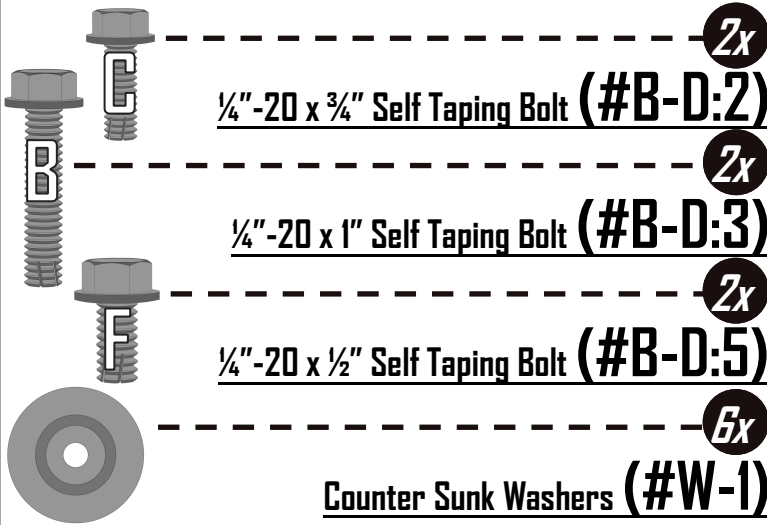

## Side bolts small bag:

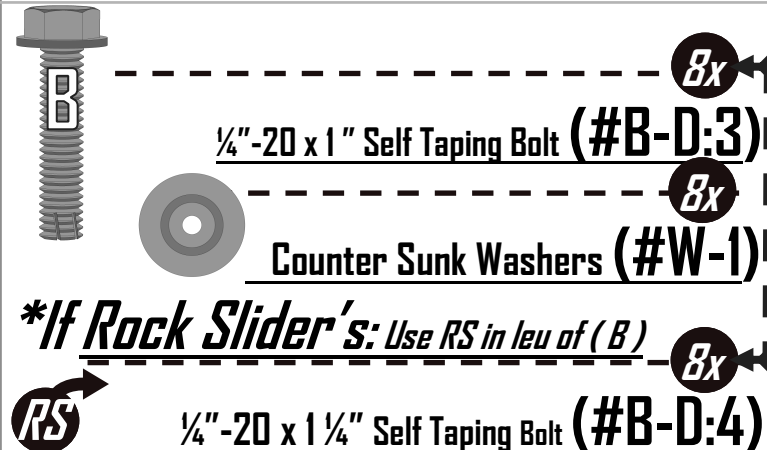

## Main Skid Large bag:

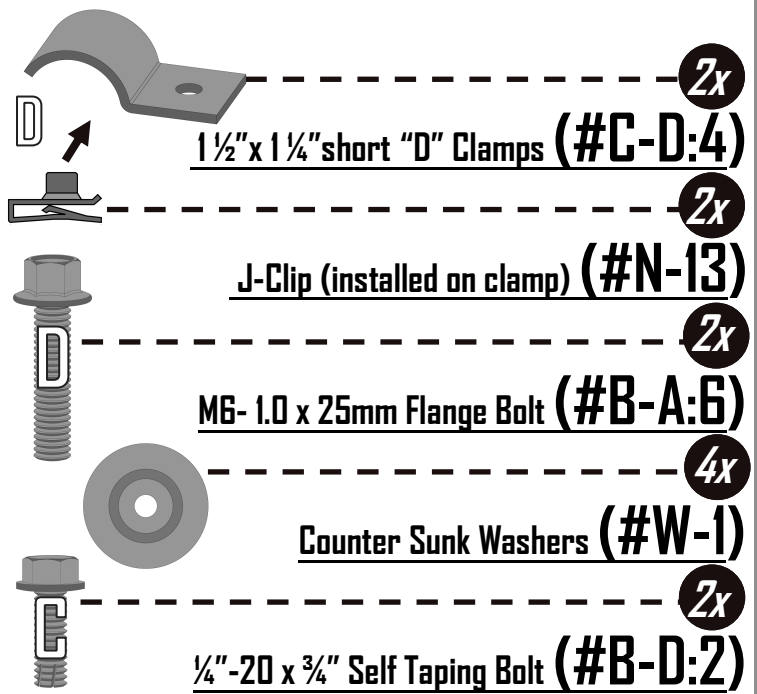

Required hardware used bolt bracket to skid for packaging

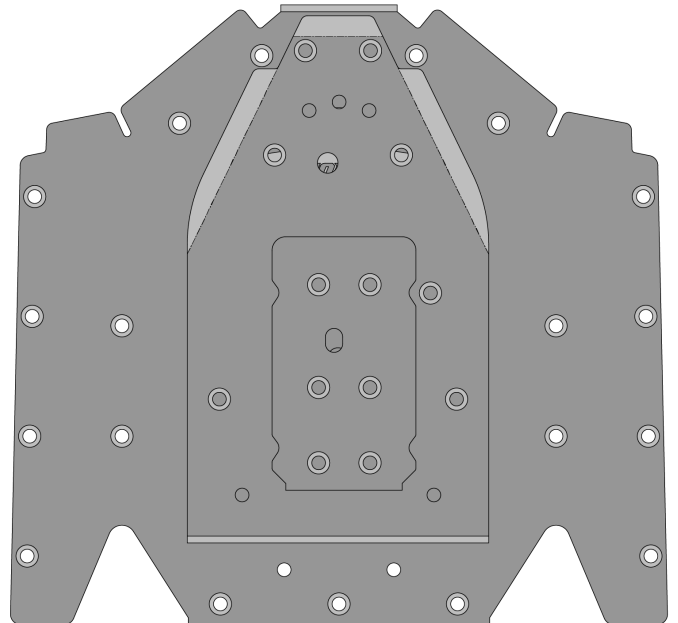
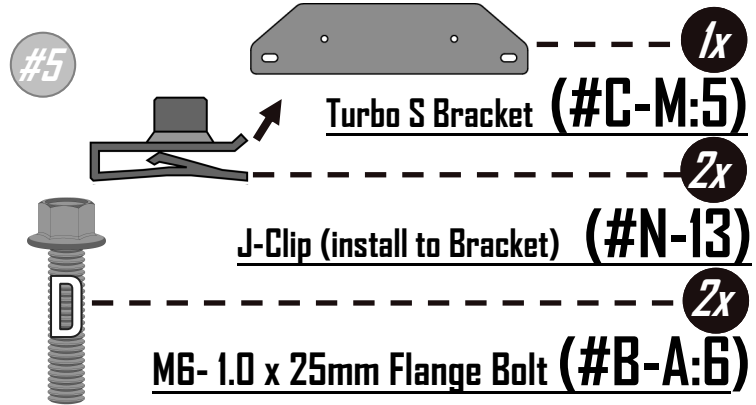

# ***Polaris RZR XP Turbo S (2019 - 2020+) Hardware***

## Trailing arm small bag:

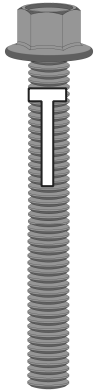

----- 10x  
1/4"-20 x 3" Hex Flange Bolt (#B-H:8)



----- 20x  
Zinc Washers (#W-4)

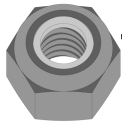

----- 10x  
1/4"-20 Ny-Lock Nut (#N-2)

## A-Arms large bag:



----- 10x  
1" x 1 3/8" "D" Clamps (#C-D:8)

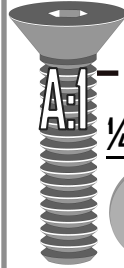

----- 10x  
1/4"-20 x 1 1/4" Counter Sunk Bolts (#B-C:2)



----- 10x  
1/4" sm Gold Washers (#W-3.0)

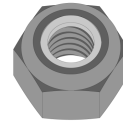

----- 10x  
1/4"-20 Ny-Lock Nut (#N-2)

# ***Polaris RZR XP Turbo S (2018) Hardware***

## Trailing arm small bag:

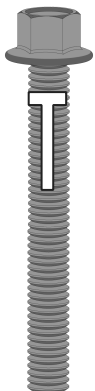

----- 10x  
1/4"-20 x 3" Hex Flange Bolt (#B-H:8)



----- 20x  
Zinc Washers (#W-4)

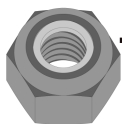

----- 10x  
1/4"-20 Ny-Lock Nut (#N-2)

## A-Arms large bag:

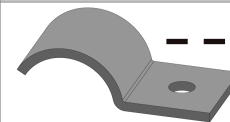

----- 10x  
1" x 1 1/4" "D" Clamps (#C-D:3)

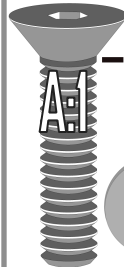

----- 10x  
1/4"-20 x 1 1/4" Counter Sunk Bolts (#B-C:2)



----- 10x  
1/4" sm Gold Washers (#W-3.0)

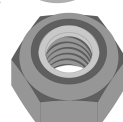

----- 10x  
1/4"-20 Ny-Lock Nut (#N-2)

Go online to [www.FactoryUTV.net](http://www.FactoryUTV.net) and check out our other Turbo S products:

Steel Front Bumper  
with UHMW Bash Plate

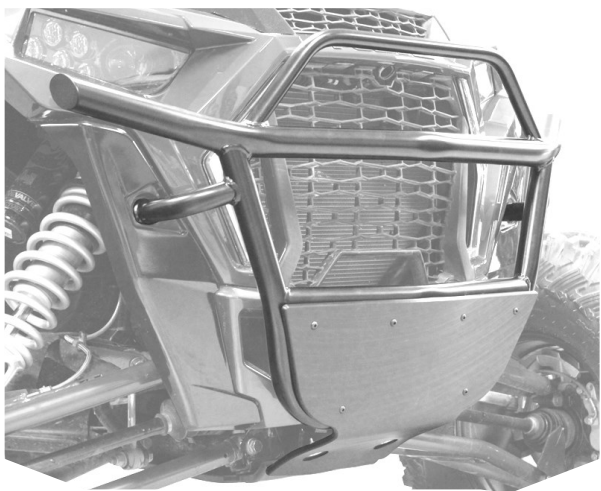

Aluminum  
X-Brace Plate  
(Rear diff skid re-enforcement)

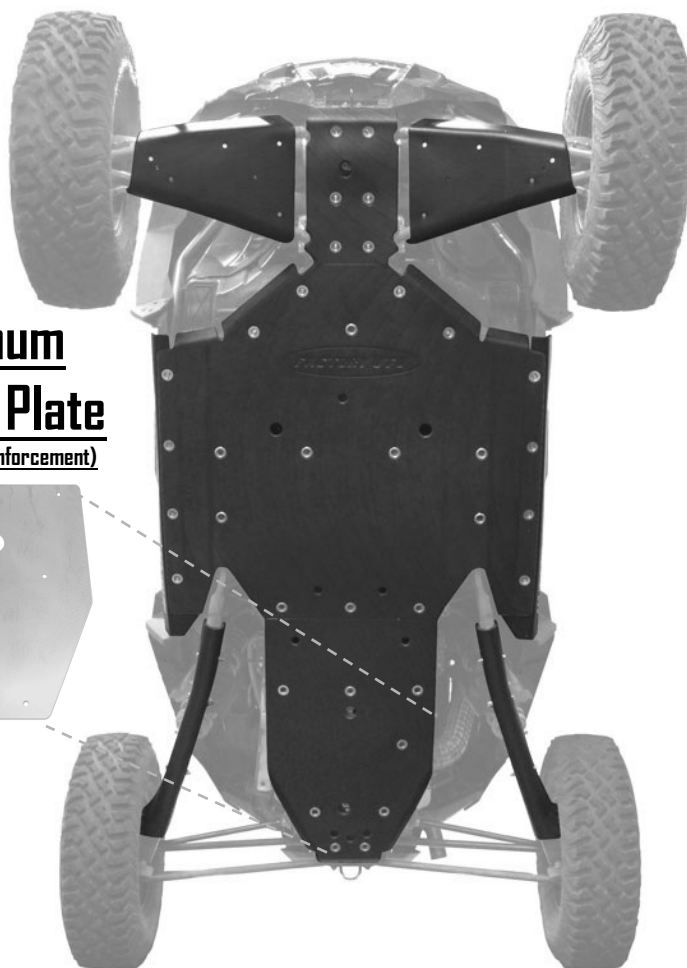
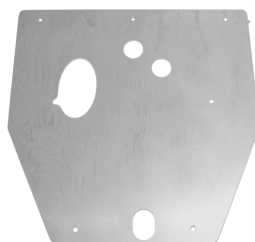

Dual Clamp  
Spare Tire Mounts

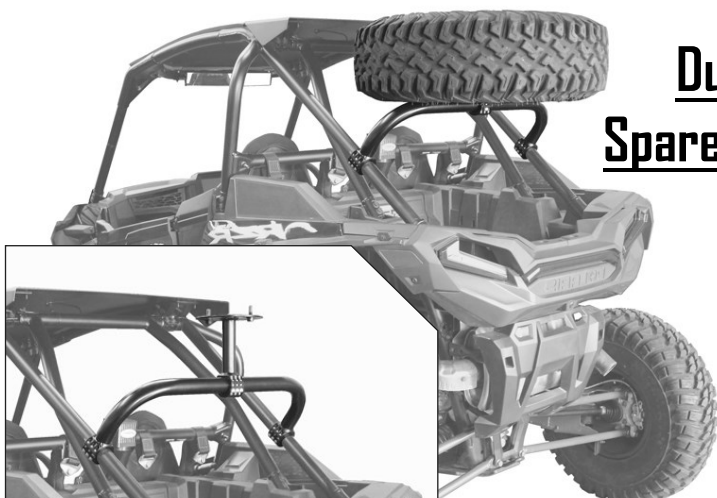

Standard Height

Above The Roof

If upgrading to an aftermarket wheel, contact us with the post measurement (see web page for details) and we can sell you just the post, to accompany your upgrade.

