

Contact Us: FACTORY UTV LLC

9237 Beatty Drive Sacramento, CA 95826

Phone : (916) 383-2730

E-mail : info@factoryutv.net

Go online: www.Factoryutv.net



U.H.M.W. Skid Plate / Under Armor Package

Ultra. High. Molecular. Weight. polyethylene all terrain skid plate / under armor kit for UTV's

Installation Guide (Ultimate Package)

***Polaris RZR XP 1000* (2014 - 2021+)**

Fits: XP 1000 :

*EPS, Dynamix, High lifter Edition, Ride Command, Trails and Rocks, LE, Premium, Sport -
XP Turbo EPS, XP Turbo EPS Dynamix, XP Turbo EPS Fox Edition, XP Turbo LE.*



Polaris RZR XP 1000 (2014 - 2021+) Instructions

Remove stock skid plate and re-use stock hardware as needed in all (A) locations.

Skid's will form to vehicle for an even better fit over time.

#1

Main Skid Plate :

Install using : (10x) Stock Bolts in Main Skid: (A) locations,
Install: (4x) M6-1.0 x 25mm Flange Bolts with "D" Clamps in Main Skid: (D) locations.
Defer side (B) locations Until Step (#4)



#2

Rear Skid Plate :

Align edge with main skid plate

Install: (7x) or (9x) 1/4"-20 x 1" Self Tapping Bolts depending on the year of the vehicle (2014-2016)
W/ (2x) U.M.H.W. Spacers in Rear skid: (B) locations. (2017+ models, spacers are not needed)
(Mount forward bolts first, to aid positioning of rear spacers between skid and chassis frame.)



#3

Front Diff. Skid Plate (C):

(See Drilling Instructions Below) Align edge with Main Skid. Mark, drill and
install: (4x) 1/4"-20 x 3/4" Self Tapping Bolts in Diff. Skid : (C) locations.



#4

Main Skid Side Mounts (B):

(See Drilling Instructions Below)

Align, mark, drill, and Install: (8x) 1/4"-20 x 1" Self Tapping Bolts in Main Skid : (B) locations.

RS

If Rock Sliders (B):

Use: (8x) 1/4"-20 x 1 1/4" Self Tapping Bolts, "RS" bolts In main skid : (B) locations.
In lieu of side bolts (1/4"-20 x 1" Self Tapping Bolts) Place in-between skid and chassis Frame.
(Rocksliders can be modified to accommodate most side mounted nerf bars)



*Ensure ALL Bolts Are Fastening Securely before use.

* Drilling Instructions : *

Use a : #Nº7 (13/64th) drill bit,

(one size above the commonly available 3/16th bit) Recommended 1/4"- 20 Tap *(Optional)

To drill and thread self tapping bolts in to chassis frame.

Finger Thread All Bolts Prior To Fastening Securely With Power Tools.

We strongly recommend the use of a "Thread Locking Compound" when installing any mounting hardware.

(When installation is complete , ensure all bolts are fastened securely.)

Polaris RZR XP 1000 Instructions (2014 - 2021+)

Read :
Instructions on pg.#2
Remove stock skid plate,
reuse hardware as needed.
Use D clamps over tubing.
Skid plate will form
to fit over time.

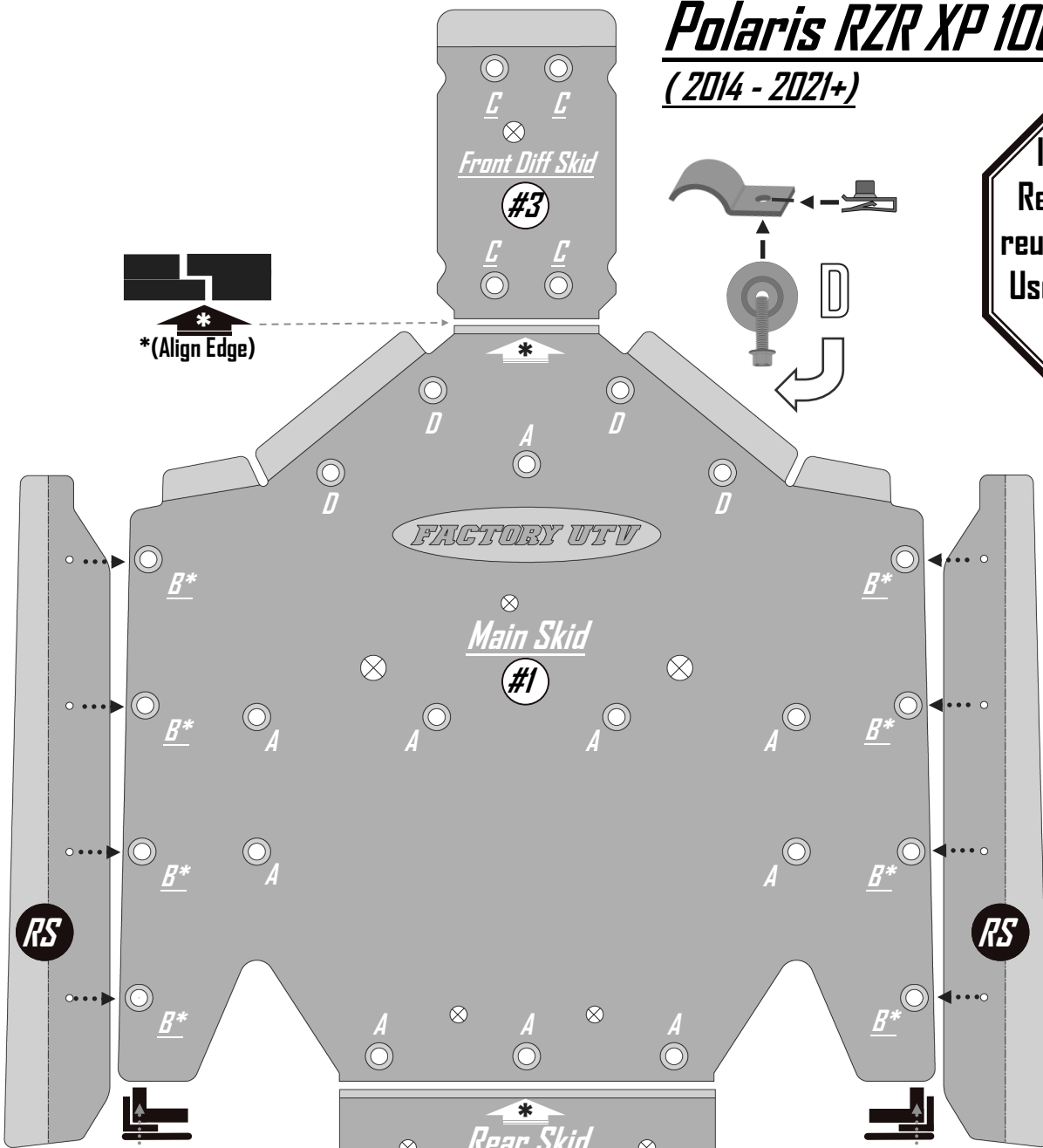

" _ " Underscore locations require drilling.

" * " Star locations can use RS bolts

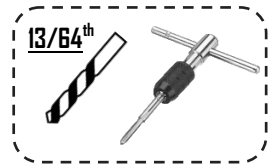

(1/4" - 20) Tap
Recommended for drilled locations



Use of clamps and/or Floor jack may aid in installation.

If Installing X-Brace or *Rocksliders

Mount in between skid and chassis frame.
Use same mounting locations.
(Rocksliders use provided longer bolts)

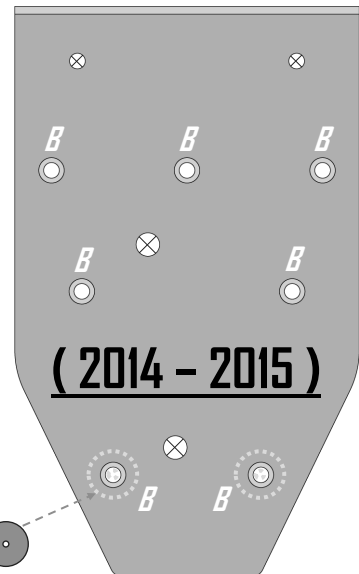
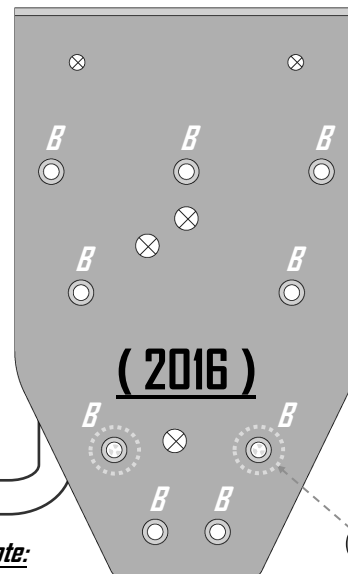
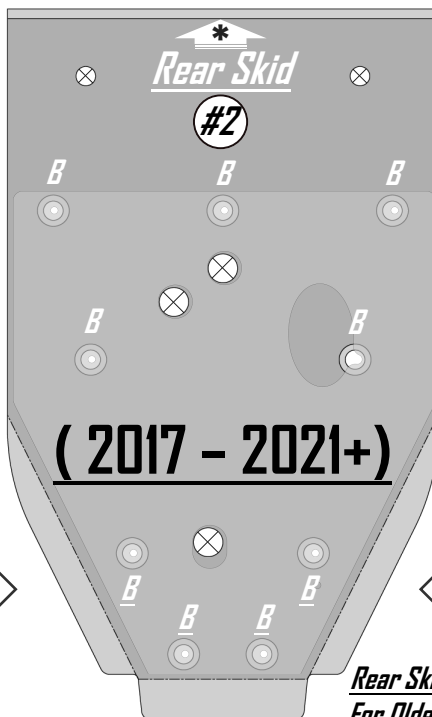
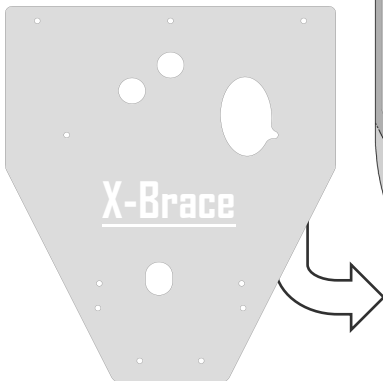

Note:
Rear Skid Differences For Older Year Models

Spacer placement
(Not needed for 2017 - 2021+ models)

⊗ = Drainage Holes
Do Not Use For Mounting

Factory UTV Polaris RZR XP 1000 Skid Plate Hardware (2014 - 2021+)

#1 Main Skid Large bag:

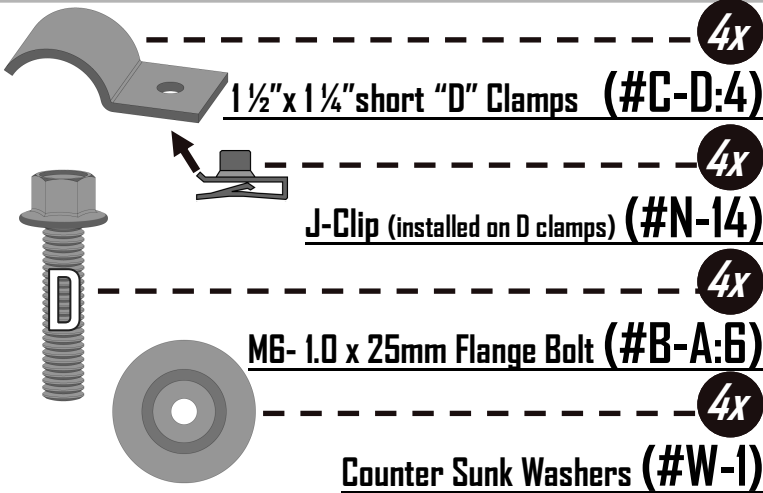

#2 Rear Skid small bag:

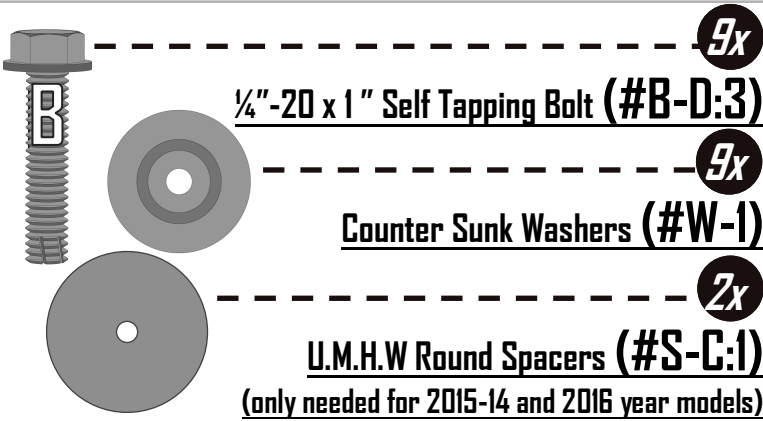

#3 Front Diff Skid small bag:

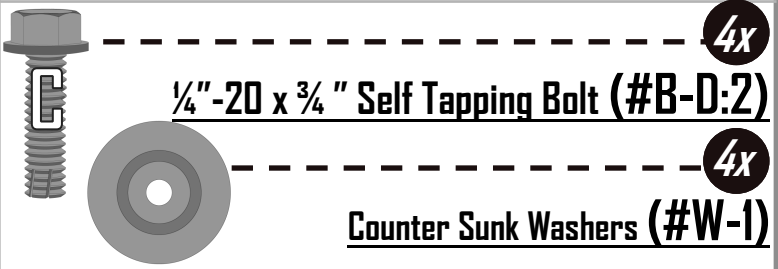

#4 Side Skid small bag:

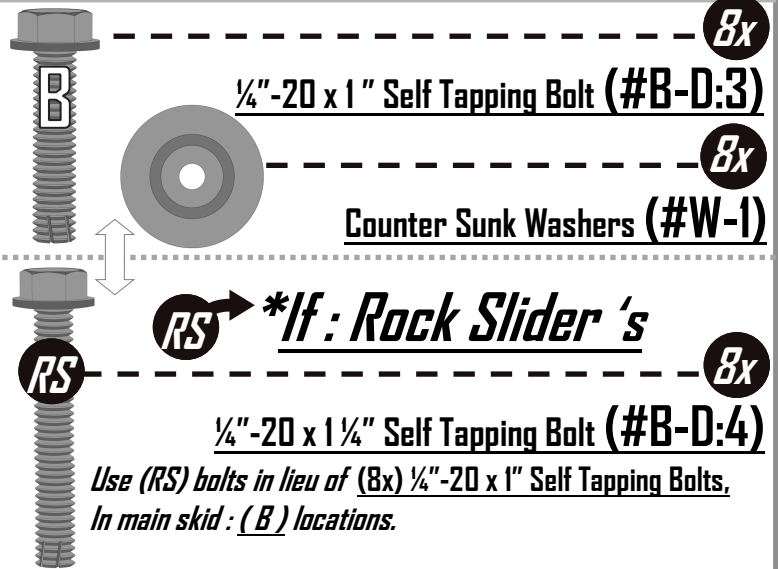

A-Arm Guard Hardware

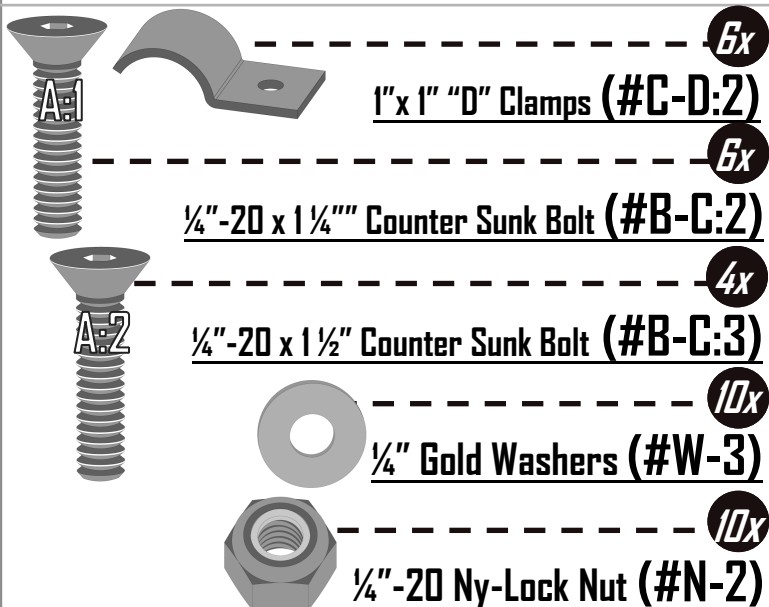

Trailing arm guard hardware

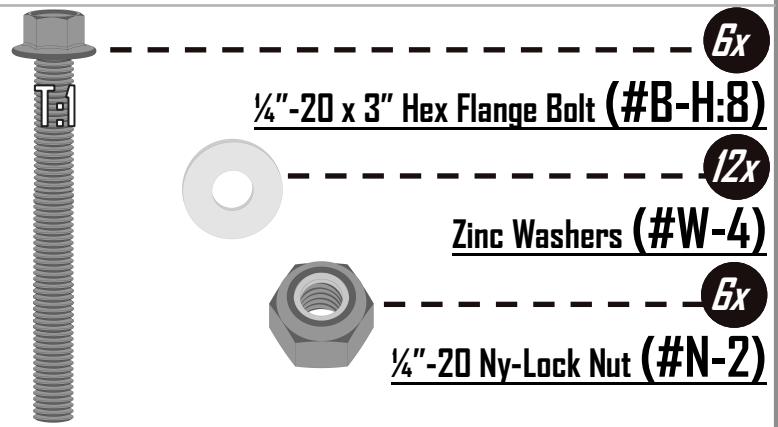

High Clearance A-Arms - use:
8x (C-D: 2), 8x (B-C: 2), 8x (W- 3), 8x (N- 2)

Polaris RZR XP 1000 (2014 - 2021+) A-Arm Guard installation

Fasten Loosely to allow for fitment adjustments, secure all bolts when complete.

Do Not Over Tighten Bolts Through Guards

Standard XP 1000 A-arm guards:

Hold in place, Use (3x) "D" clamps, (3x) 1/4"-20 x 1/4" Counter Sunk Bolts, (3x) Gold Washers w/ (3x) 1/4"-20 Ny-Lock Nuts in A-Arm Guard: (A:1) locations.

Use: (2x) 1/4"-20 x 1/4" Counter Sunk Bolts, (2x) Gold Washers w/ (2x) 1/4"-20 Ny-Lock Nuts, in A-Arm Guard: (A:2) locations.

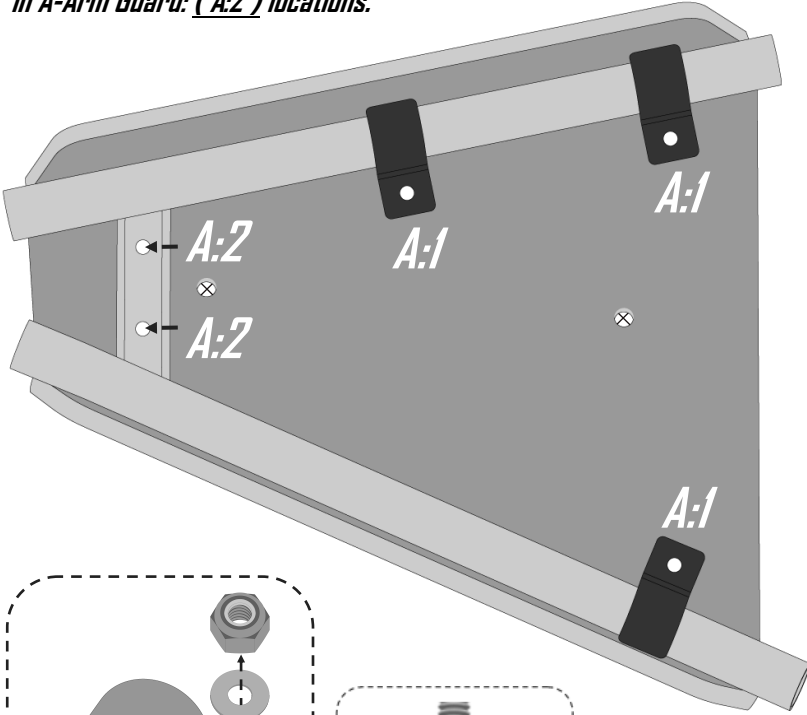

A-Arm Guard Hardware

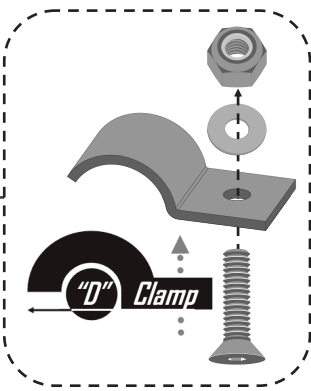
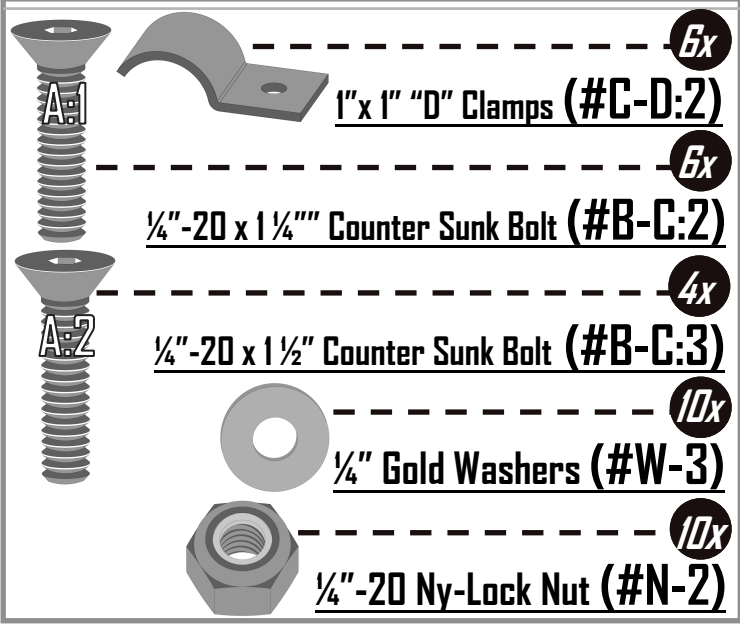

Fasten bolts until flush DO NOT over tighten

Polaris High Clearance A-Arm Guards (for High lifter or Trails and Rocks Editions)

Hold in place, Use (4x) "D" clamps, (4x) 1/4"-20 x 1/4" Counter Sunk Bolts, (3x) Gold Washers w/ (4x) 1/4"-20 Ny-Lock Nuts in A-Arm Guard: (A:1) locations.

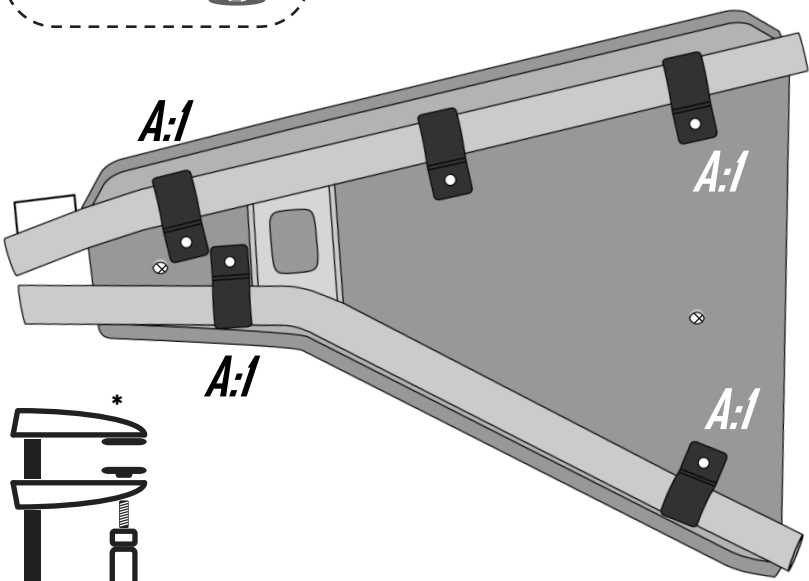

Polaris High Clearance A-Arm Guard

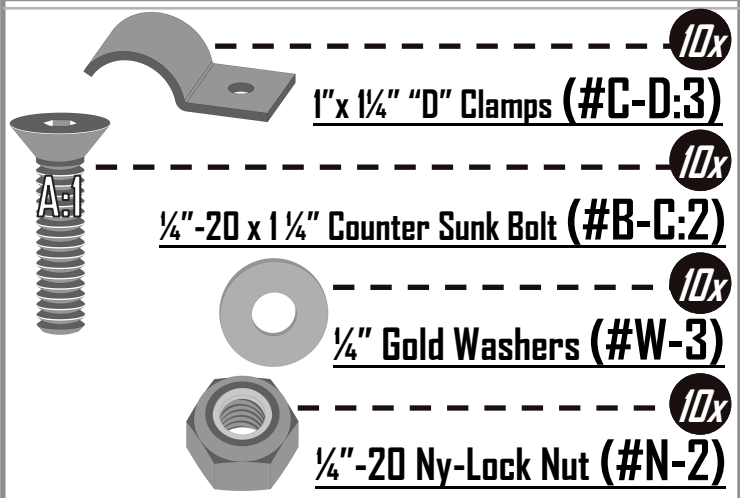

* Install Tip: Use of clamps may help with fitment and aid with fastening bolts.

⊗ = Drainage Holes Do Not Use For Mounting

Polaris RZR XP 1000 (2014 - 2021+) Trailing Arm Guard installation

Fasten Loosely to allow for fitment adjustments, secure all bolts when complete.

Do Not Over Tighten Bolts Through Guards

Trailing arm guards



Using: (3x) 1/4"-20 x 3" Hex Flange Bolts, With (6x) Zinc Washers (one on each side), And (3x) 1/4"-20 Ny-Lock Nuts. in Trailing-Arm Guard: (T:1) locations.

Install with Notch pointing outwards, Away from vehicle.

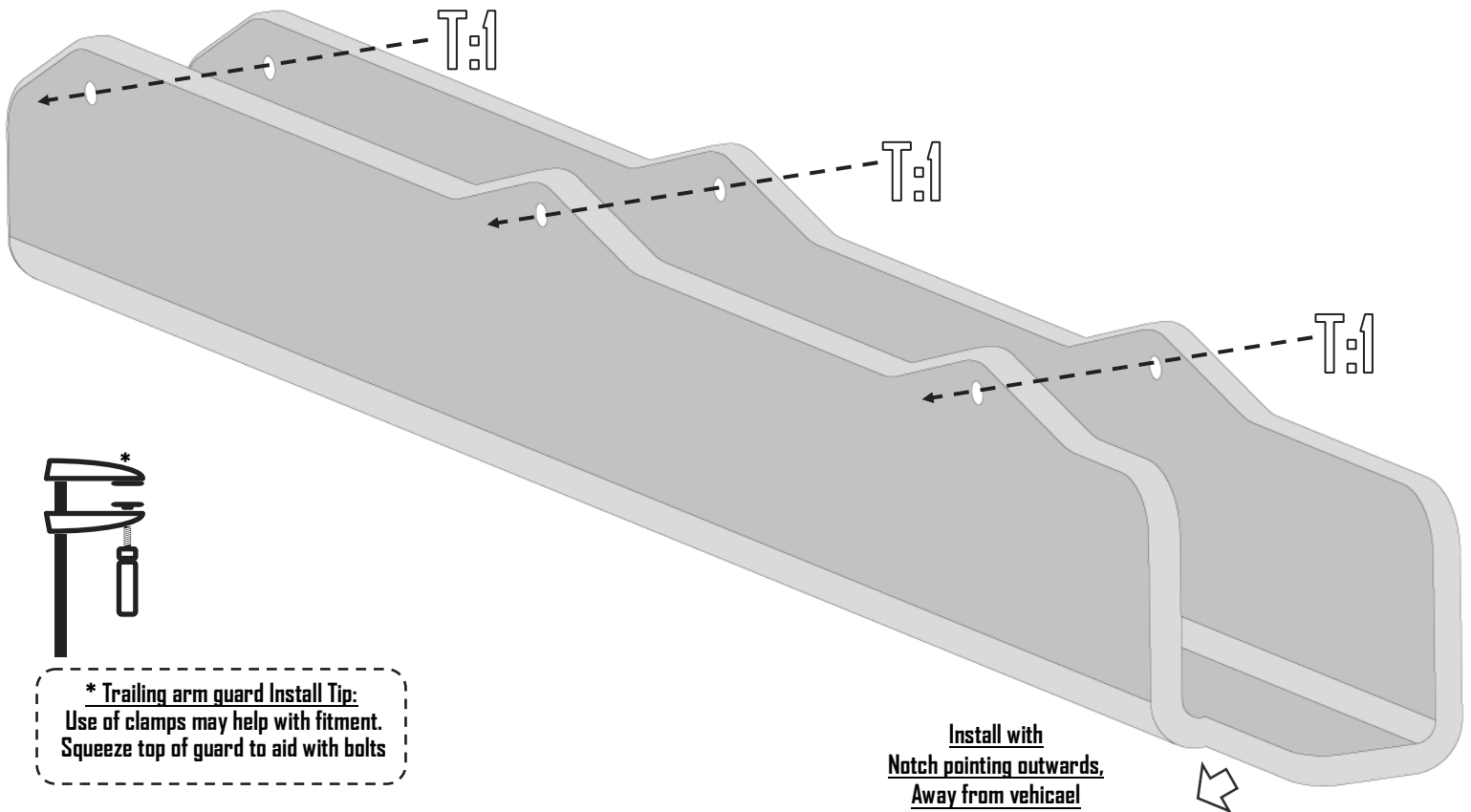
(May need to use clamps and or car jack to aid with install)

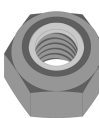

Trailing arm guard hardware

	-----	6x
T:1	1/4"-20 x 3" Hex Flange Bolt (#B-H:8)	
	-----	12x
	Zinc Washers (#W-4)	
	-----	6x
	1/4"-20 Ny-Lock Nut (#N-2)	