

**Contact Us: *FACTORY UTV LLC***

9237 Beatty Drive Sacramento, CA 95826

Phone : (916) 383-2730

E-mail : [info@factoryutv.net](mailto:info@factoryutv.net)

Go online: [www.Factoryutv.net](http://www.Factoryutv.net)



## **U.H.M.W. Skid Plate / Under Armor Package**

*Ultra. High. Molecular. Weight. polyethylene all terrain skid plate / under armor kit for UTV's*

# ***Polaris RZR 170***

***( 2009 - 2021+ )***

## **Installation Guide**



# Polaris RZR 170 (2009 - 2021+) Instructions

#1

## Remove: 8x stock bolts in floorboard

Remove: (8x) stock bolts in floorboard and replace with (A) Bolts in Main Skid : (A) locations. ( See diagram on page 2 )

#2

## Front Main Skid Plate :

You may need assistance, or the use of a car jack, to help hold skid in place.

Install: (8x) M6-1.0 x 45mm Flange Bolts and (8x) ¼" Silver Zinc Washers, Down Through Floorboard with (8x) Counter sunk washers, and (8x) M6- 1.0 flange Nuts in Main Skid : (A) locations.

#3

## Rear Main Skid Plate :

Install: (4x) 1" x 1 ¼" -"D" Clamps each with (1x) ¼"-20 x 1" Counter Sunk Bolt, (1x) ¼" Gold Washer, and (1x) ¼"-20 Ny-Lock Nut

Install "D" clamps over vehicle tube framing In Main Skid : (B) locations.

*Tighten counter sunk bolts until bolt head is Flush with UHMW. DO NOT Over Tighten Bolts*

#4

## Front Diff. Skid Plate :

Holding the front diff skid in place, loosely Install: (2x) 1" x 1 ¼" -"D" Clamps ".2" with (1x) ¼"-20 x 1" Counter Sunk Bolts "C", (1x) ¼" Gold Washer, and (1x) ¼"-20 Ny-Lock Nut in front Diff. Skid : (C.2) locations.

Install: (1x) 1" x 1" -"D" Clamp ".1" with (1x) ¼"-20 x 1 ¼" Counter Sunk Bolt "C", (1x) ¼" Gold Washers, and (1x) ¼"-20 Ny-Lock Nut in front Diff. Skid : (C.1) location, Fasten all bolts securely. Do not over tighten.

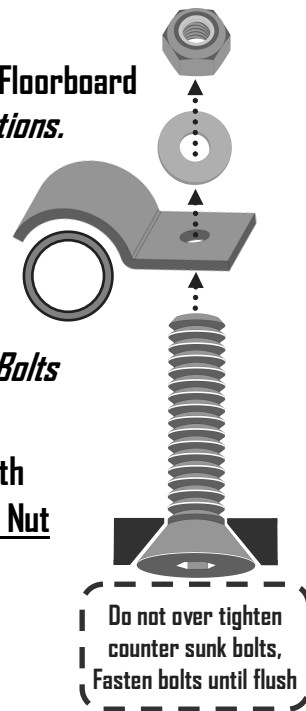

#a

## ( 2009-2013 ) Rear Swing Arm Guard :

Align swing arm guard, hold or clamp in place

Install: (3x) 1" x 1 ¼" -"D" Clamps over swingarm frame tubing with (3x) ¼"-20 x 1" Counter Sunk Bolts, (3x) ¼" Gold Washers, and (3x) ¼"-20 Ny-Lock Nuts in Rear Swing Arm : (B) locations.

Align, mark and \*Drill remaining (2x) rear holes in (D) locations.

Install : (2x) ¼"-20 x 1" Counter Sunk Bolts, (2x) ¼" Gold Washers, and (2x) ¼"-20 Ny-Lock Nuts in (D) locations.



#b

## ( 2014-2020+ ) Rear Swing Arm Guard :

\*(if ordered a full replacement swingarm kit, hardware is pre-assembled)

Install: (6x) 1" x 1 ¼" -"D" Clamps over swingarm frame tubing with (6x) ¼"-20 x 1 ¼" Counter Sunk Bolts, (6x) ¼" Gold Washers, and (6x) ¼"-20 Ny-Lock Nuts in Rear Swing Arm : (C) locations.

## \* Drilling Instructions : \*

Use a : #No7 (13/64<sup>th</sup>) drill bit,

( one size above the commonly available 3/16<sup>th</sup> bit ) Recommended ¼"- 20 Tap \*( Optional )

To drill and thread self tapping bolts in to chassis frame.

Finger Thread All Bolts Prior To Fastening Securely With Power Tools.

We strongly recommend the use of a "Thread Locking Compound" when installing any mounting hardware.

( When installation is complete , ensure all bolts are fastened securely.)

# Polaris RZR 170 (2009-2021+)

**Read :**  
 Instructions on pg.#2  
 Remove stock skid plate.  
 You May need assistance  
 holding skid in place,  
 or the use of a car jack  
 during install.

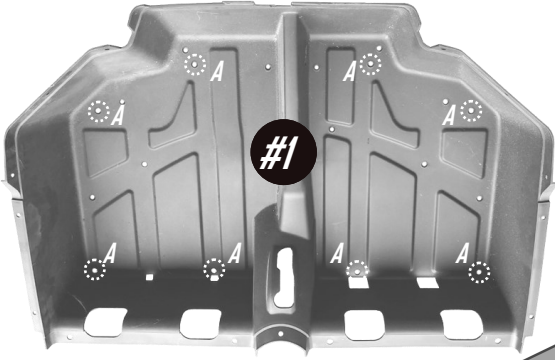

**#4** C.1  
**Front Diff. Skid**  
 C.2 C.2

⊗ = Drainage Holes  
 Do Not Use For Mounting

Remove stock bolts from these (A) floorboard locations and reinstall with (A) bolts. From the bottom use counter sunk washers and Nylock nuts.

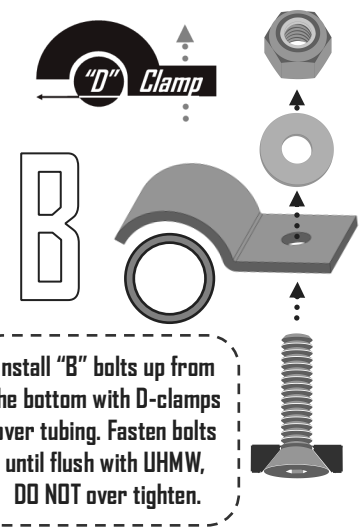
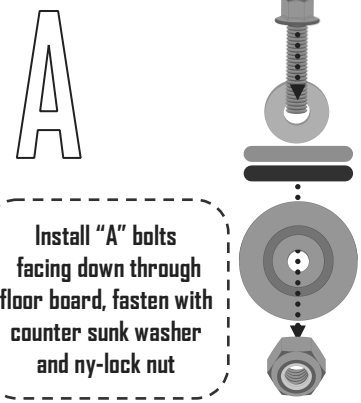
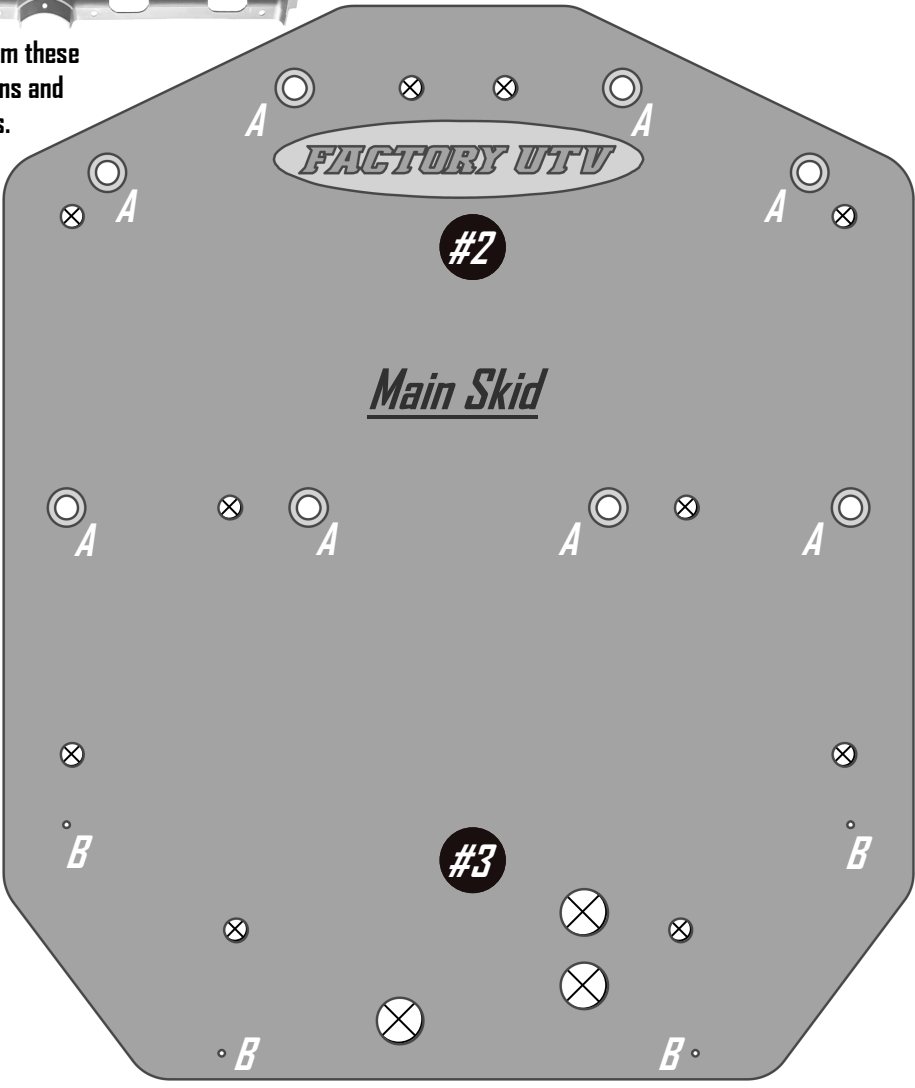

## Swing Arm Guard

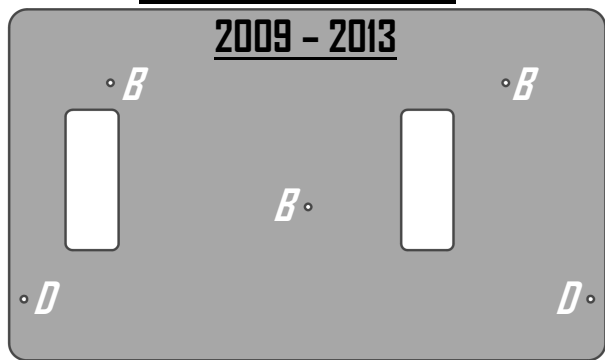



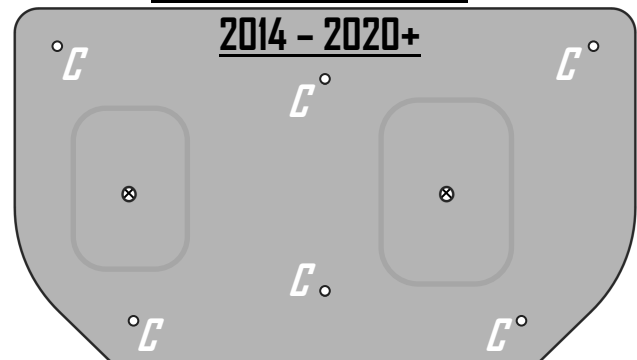

## Swing Arm Guard



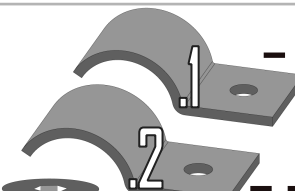
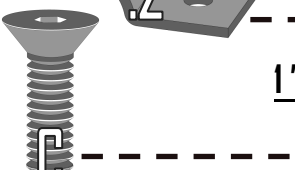

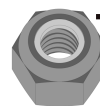



# Polaris RZR 170 (2009-2021+) Hardware kit

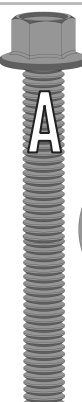
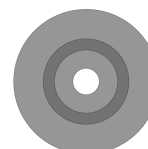

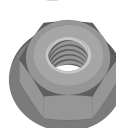
**#1 Front Diff. Large bag :**

-  1x 1" x 1" "D" Clamps (#C-D:2)
-  2x 1" x 1 1/4" "D" Clamps (#C-D:3)
-  3x 1/4"-20 x 1 1/4" Counter Sunk Bolts (#B-C:2)
-  3x 1/4"-20 Ny-Lock Nut (#N:2)
-  3x 1/4" Gold Washers (#W:3)

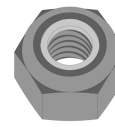

**#2 Main Skid Large bag :**

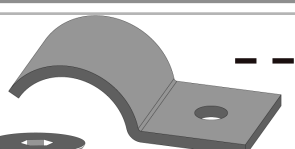
-  8x MG-1.0 x 45mm Flange Bolt (#B-A:10)
-  8x Counter Sunk Washers (#W:1)
-  8x 1/4" Silver Zinc Washers (#W:4)
-  8x MG-1.0 Flange Nut (#N:1)
-  4x 1" x 1 1/4" "D" Clamps (#C-D:3)
-  4x 1/4"-20 x 1" Counter Sunk Bolts (#B-C:1)
-  4x 1/4" Gold Washers (#W-3)
-  4x 1/4"-20 Ny-Lock Nut (#N:2)

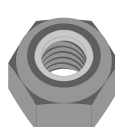
**-13 Swing Arm Guard large bag : (2009 – 2013)**

-  3x 1" x 1" "D" Clamps (#C-D:2)
-  5x 1/4"-20 x 1" Counter Sunk Bolts (#B-C:1)
-  5x 1/4" Gold Washers (#W-3)
-  5x 1/4"-20 Ny-Lock Nut (#N:2)

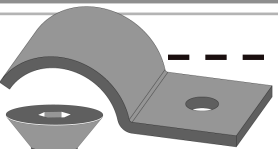
**14+ Swing Arm Guard large bag : (2014 – 2020+)**

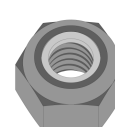
-  6x 1" x 1 1/4" "D" Clamps (#C-D:3)
-  6x 1/4"-20 x 1 1/4" Counter Sunk Bolts (#B-C:2)
-  6x 1/4" Gold Washers (#W-3)
-  4x 1/4"-20 Ny-Lock Nut (#N:2)