

Contact Us: **FACTORY UTV LLC**

9237 Beatty Drive Sacramento, CA 95826

Phone : (916) 383-2730

E-mail : info@factoryutv.net

Go online: www.Factoryutv.net



U.H.M.W. Skid Plate / Under Armor Package

Ultra. High. Molecular. Weight. polyethylene all terrain skid plate / under armor kit for UTV's

Installation Guide (Ultimate Package)

Honda Talon 1000 (2019+)

X & R models



Honda Talon 1000 X-R (2019+) Instructions

#1

Remove stock skid plate and re-use stock washers as needed

Install Extension Bracket: Using (3x) M6- 1.0 x 20mm Flange Bolts in (-C-) locations, with out counter sunk washers.
/ Or Aluminum X-Brace: Using (3x) M6- 1.0 x 20mm Flange Bolts in (-C-) locations, with out counter sunk washers.
Fasten bolts loosely, to be Re-installed with washers during main skid installation.

#2

Main Skid Plate :

Once Extension Bracket or X-brace is installed,
Install: (9x) M6-1.0 x 20mm Flange Bolts and counter sunk washers *in main skid: (C) locations.*
In (-G-) locations, remove and reinstall bolt with countersunk washer, repeat steps for remaining (-G-) Locations.
Fasten bolts loosely to allow for adjustment during install, disregard (B) locations until Rear skid plate is installed.*

#3

Rear Skid Plate :

Align edge with main skid plate,
Install: (9x) M6-1.0 x 20mm Flange Bolts in *rear skid: (C) locations.* *Fasten bolts loosely for installation adjustments.*
Install: (6x) M6-1.0 x 30mm Flange Bolts with (6x) 1/2" Nylon Spacers *in rear skid: (E+) locations.*
**If installing with X-brace in place, use (F) bolts in lieu of: (E) bolts and spacers, X-brace does not require spacers.*
Mark (A) locations , drill (9/32) mounting holes and Install :*
(2x) 1/4"-20 x 3/4" Flange Bolts with (2x) 1/4"-20" Flange Nuts *in rear skid: (A*) locations.*
Fasten all Rear skid bolts securely.



#4

For remaining Main Skid: (B*) locations:

Once rear skid is secure, mark, drill, and install: (4x) 1/4"-20 x 3/4" Self Tapping Bolts in remaining main skid: (B) locations.*

#5

Front Diff Skid Plate :

Align edge with main skid plate, hold front diff skid in place using * Clamps. Once positioned, mark and drill
(4x) 13/64th mounting holes in front diff skid (B) locations, Install: (4x) 1/4"-20 x 3/4" Self Tapping Bolts.
Drill (4x) 9/32nd mounting holes in front diff skid (D) locations, Install: (4x) 1/4"-20 x 3/4" Flange Bolts with (4x) 1/4"-20 x 3/4" Flange Nuts.
moving clamps along to help shape and bend up front of skid to frame during installation.



#6

Rock sliders :

Once main skid is installed, before installing Rock sliders:
Temporarily remove stock side plastic /or pull aside, drill (4x) 3/8" holes in stock metal bracket in (-G-) rear locations.
Install: (4x) J-clips in rear (-G-) locations on each side, with J-clip tip pointing inward, towards UTV : see (-G-) diagrams.
Install: (8x) M6 1.0 x 25mm Hex Flange Bolt in (H) locations from the bottom.
Then Install: (4x) M6 1.0 x 35mm Button head Bolt in (G) and (-G-) locations,
Fasten forward bolts first, then fasten remaining bolts, starting from front to rear,
do not over tighten. UHMW will form as fastened, to contour and fit side of UTV.
When installation is complete, ensure all bolts are fastened securely.

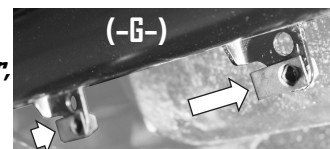
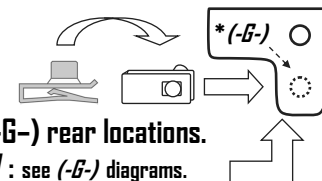

*** Drilling Instructions : ***

For Self tapping bolt locations: Use a : (13/64th) drill bit,

(one size above the commonly available 3/16th bit) Recommended 1/4"-20 Tap *(Optional) To drill and thread self tapping bolts in to chassis frame.

Drilling required for nut and bolt locations: Use a : (9/32th) drill bit.

Finger Thread All Bolts Prior To Fastening Securely With Power Tools.

We strongly recommend the use of a "Thread Locking Compound" when installing any mounting hardware.

(When installation is complete , ensure all bolts are fastened securely.)

Honda Talon 1000 X or R (2019+)

Remove stock skid,
re-use washers as needed.
Install bolts loosely for
installation adjustments,
Fasten when done.
May need use of car jack
and clamps.

Drill ($\frac{9}{32}$ nd) mounting holes
For nut and bolt (A) locations.

Nut and bolt Install tip:
some nuts may be easier to
access from opposing side.

Main skid B* locations
Drill ($\frac{13}{64}$ th) mounting holes
For Self tapping bolt (B*) locations

*Self tapping bolt Install tip:
Use of a $\frac{1}{4}$ "-20 Tap is
strongly recommended for
threading thicker steel locations.
To avoid snapping bolts.

*(Align skid Edge)

Extension bracket -OR- X-Brace install
Ensure j-clip tips are pointing up, towards vehicle.

G =

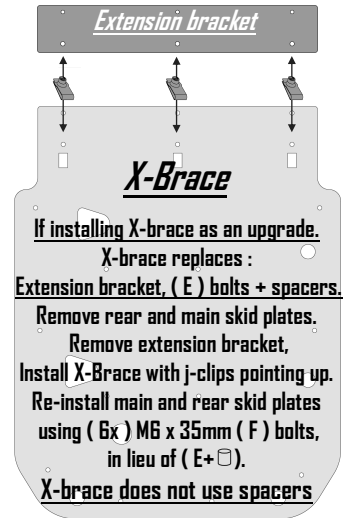
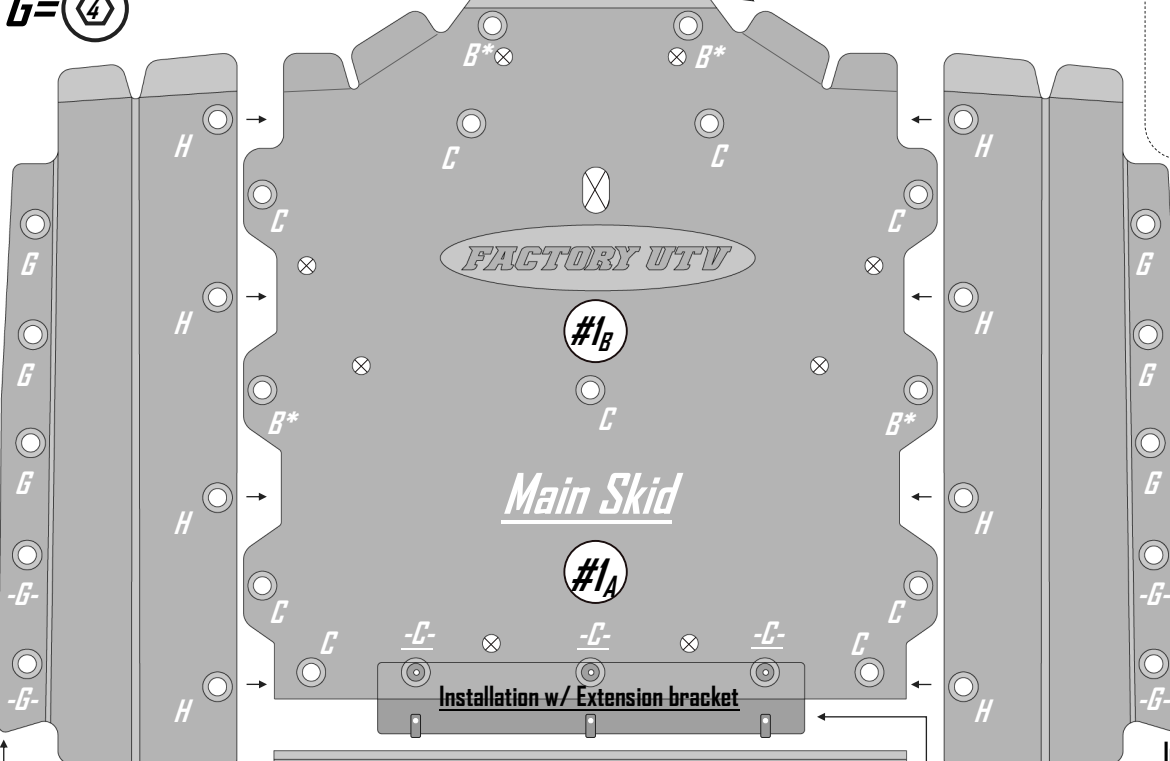
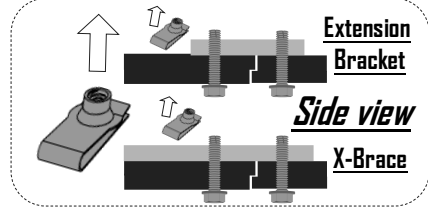

Pull Back on stock plastic
to expose -G- locations,
Re install stock plastic before
installing Rock Sliders

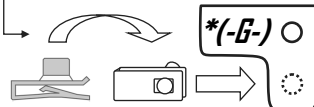

Drill 3/8" hole in (-G-) locations,
then install j-clips with tip
pointing inwards towards UTV.

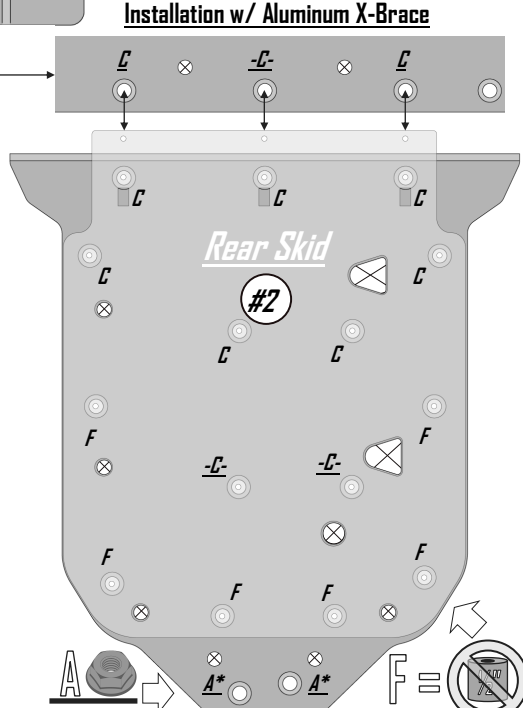
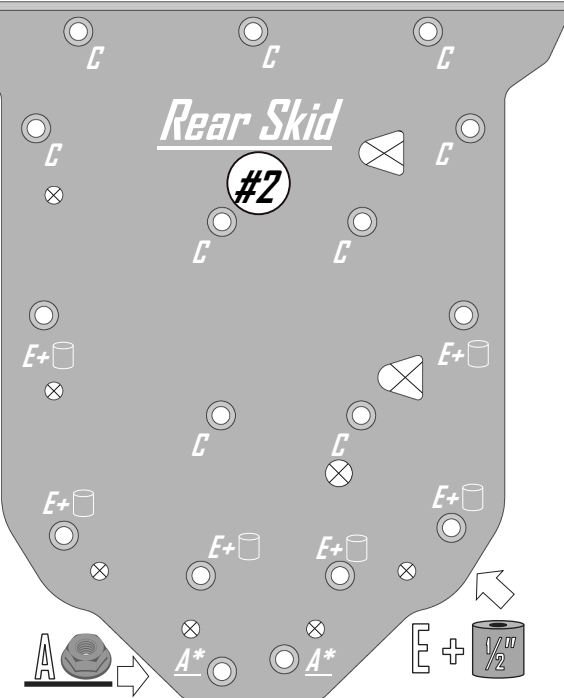
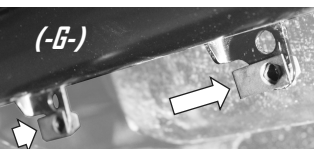

= Drainage Holes Do Not Use For Mounting

Honda Talon 1000 X-R (2019+) Skid Plate Hardware

#1 Front Diff Skid small bag:

- 4x 1/4"-20 x 3/4" Self Taping Bolt (#B-D:2)
- 4x 1/4"-20 x 1" Flange Bolt (#B-A:3)
- 4x 1/4"-20 Flange Nut (#N-3)
- 8x Counter Sunk Washers (#W-1)

#2 Main Skid small bag:

- 4x 1/4"-20 x 3/4" Self Taping Bolt (#B-D:2)
- 12x M6- 1.0 x 20mm Flange Bolt (#B-A:5)
- 16x Counter Sunk Washers (#W-1)

#3 Rear Skid Large bag:

- 2x 1/4"-20 x 3/4" Hex Flange Bolt (#B-A:2)
- 9x M6- 1.0 x 20mm Flange Bolt (#B-A:5)
- 6x M6- 1.0 x 30mm Flange Bolt (#B-A:7)
- 10x Counter Sunk Washers (#W-1)
- 2x 1/4"-20 Flange Nut (#N-3)
- 6x 1/2" Nylon Spacers (#S-R:4)

#4 Rock sliders small bag:

- 8x M6 1.0 x 25mm Hex Flange Bolt (#B-A:6)
- 10x M6 1.0 x 35mm Button head Bolt (#B-B:4)
- 4x J-Clips (#N-13)
- 18x Counter Sunk Washers (#W-1)

1x Extension Bracket (#E-B:11)

(Bracket Packaged to skid plate, use hardware as required for installation)
3x (B-A-5) bolts and 3x (W-1) washers, from main skid bag.

3x J-Clip (installed on Extension bracket) (#N-13)

***if X-Brace use same (3x) J-clips above**
X-brace kit Replaces : Extension Bracket, (E) Bolts + Nylon Spacers.
With: (6x) M6- 1.0 x 35mm (F) bolts, No spacers.

1x X-Brace (#X-B:3)

With large drain holes to the left, install j-clips with tips pointing up.

6x M6- 1.0 x 35mm Flange Bolt (#B-A:8)

Use (F) bolts in lieu of (E) bolts and Nylon Spacers in Rear Skid bag

Honda Talon 1000 (R) & (X) A-Arm Guard installation

A-Arm Guard Installation

Hold A-arm guard in place, loosely install bolts through guard and "D" clamps. Fasten bolts with washers and Ny-lock nuts, fastening down in an even pattern. Securely fasten to a-arm until flush, do not over tighten bolts deep in to plastic. Installation may require the use of a floor jack and firm upwards pressure for fitment. **Optional:* to install with stock CV guards, Require modification and/or firmly applied pressure during fastening.

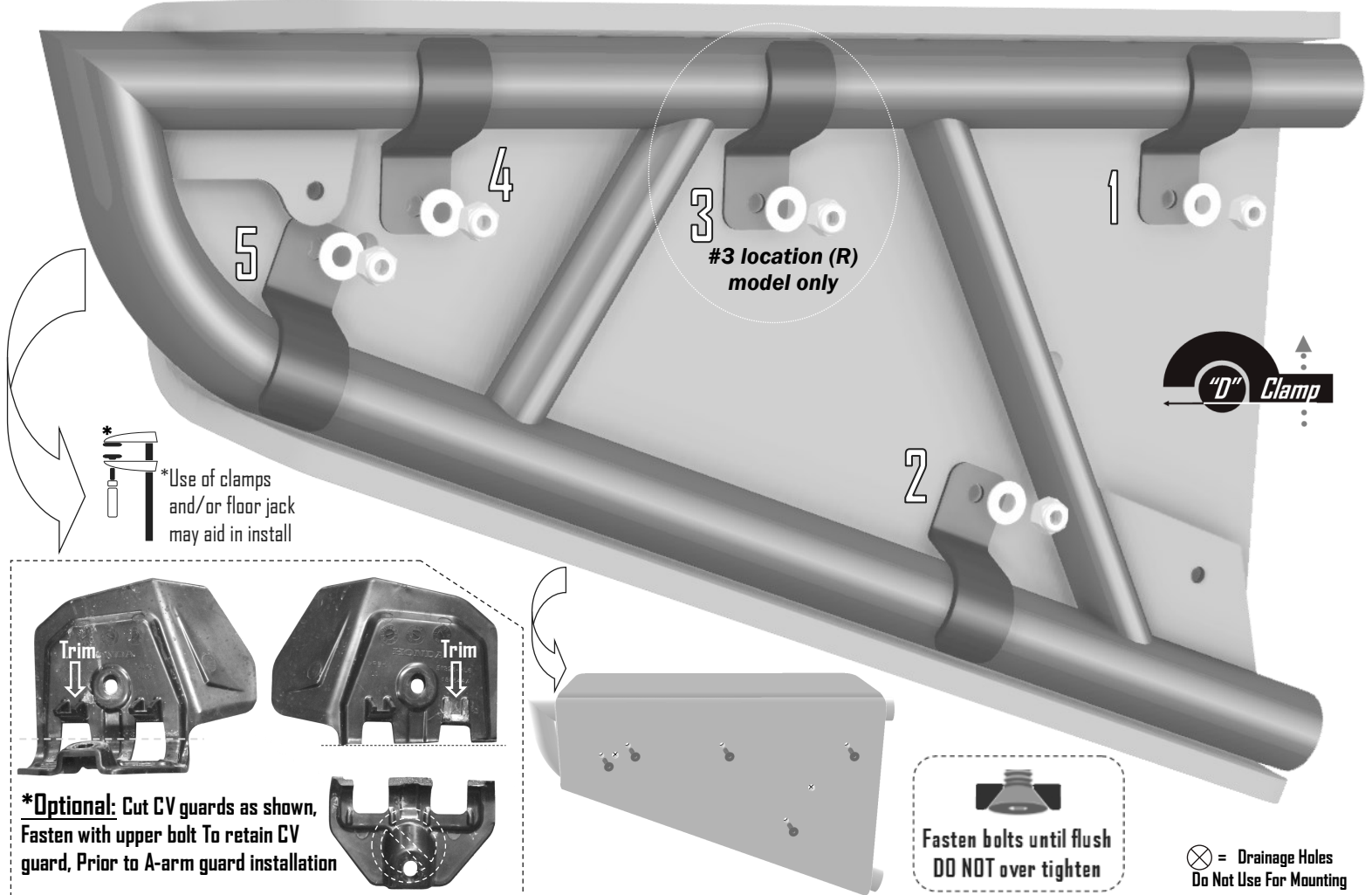
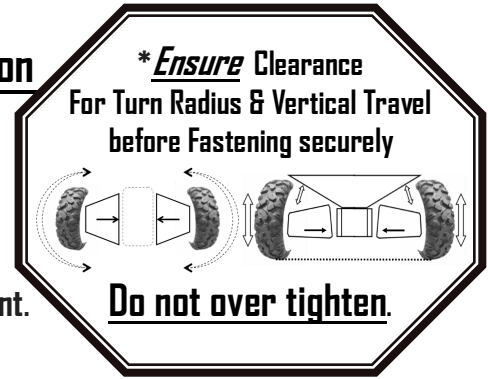

(R) A-Arm Guard Hardware:	
	10x 1" x 1 1/4" "D" Clamps (#C-D:3)
	10x 1/4"-20 x 1 1/4" Counter Sunk Bolts (#B-C:2)
	10x 1/4"sm Gold Washers (#W-3.0)
	10x 1/4"-20 Ny-Lock Nut (#N-3)

(X) A-Arm Guard Hardware:	
	8x 1" x 1 1/4" "D" Clamps (#C-D:3)
	8x 1/4"-20 x 1 1/4" Counter Sunk Bolts (#B-C:2)
	8x 1/4"sm Gold Washers (#W-3.0)
	8x 1/4"-20 Ny-Lock Nut (#N-3)

Honda Talon 1000 (R) & (X) Trailing-Arm Guard Installation

Trailing-Arm Guard Installation

Hold Trailing arm guard in place,

Install: 1/4"-20 x 3" Hex Flange Bolts through Trailing arm guard,

Fasten with Zinc Washers and Ny-lock nuts in T:l locations.

Installation may require the use of a floor jack and firm upwards pressure for fitment.

(Removal of rear wheel may be required)



R

Trailing Arm Guard

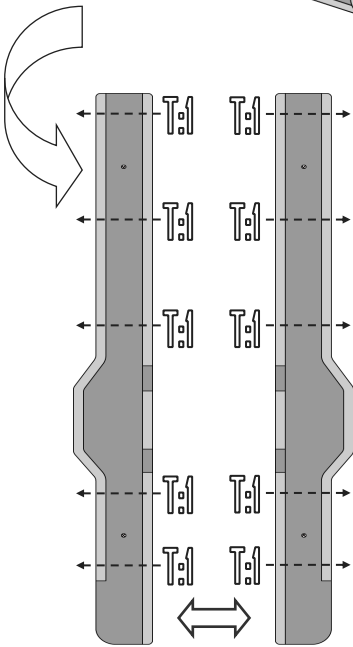
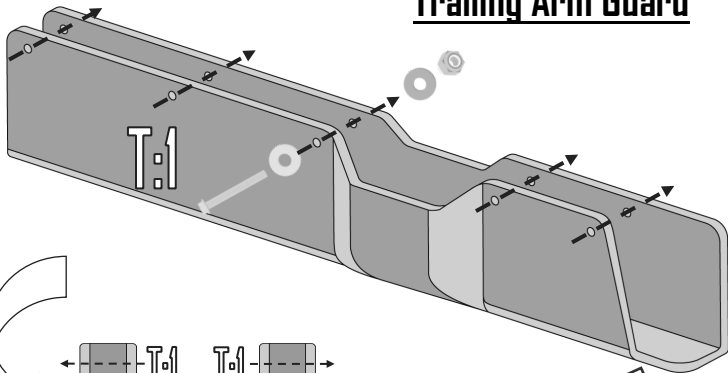

Install with notched edge's facing away from vehicle

*** Trailing arm guard Install Tip:**
Use of clamps may help with fitment.
Squeeze top of guard to aid with bolts



⊗ = Drainage Holes
Do Not Use For Mounting

X

Trailing Arm Guard

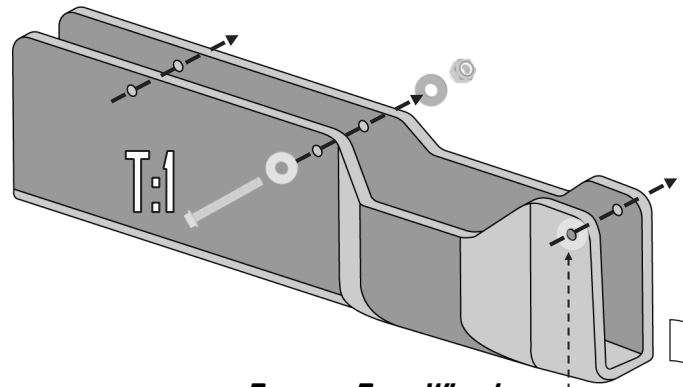

Remove Rear Wheel for last bolt locations

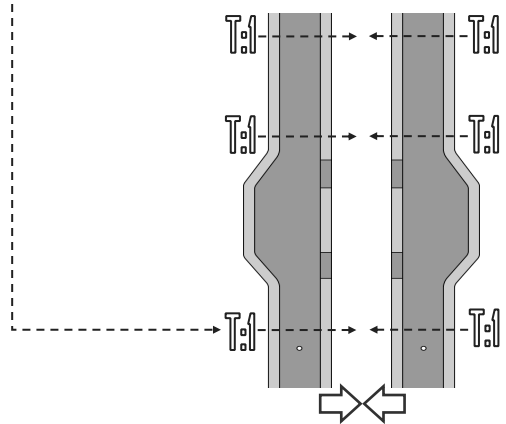

R

(R) Trailing arm guard Hardware:

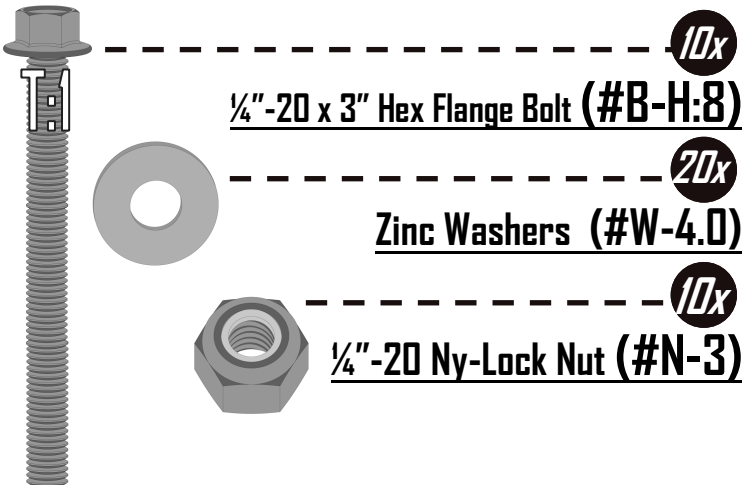

X

(X) Trailing arm guard Hardware:

