

BST-IT705 5kV HIGH VOLTAGE INSULATION TESTER



INSTRUCTION MANUAL

Index	Page
1. Safety Precautions.....	1-2
2. Overview.....	2
3. Features.....	3
4. Specifications.....	4
5. Connections.....	5
6. Instrument layout.....	6
7. Measuring procedure.....	7-14
8. Charge.....	15
9. Maintenance & repair.....	16
10. Interface connection and operation.....	17-24

1. Safety Precautions

Electricity can cause severe injuries even with low voltages or currents.

Therefore it is extremely important that you read the following information before using your high voltage insulation tester.

- a. This Instrument must only be used and operated by a competent trained person and in strict accordance with the instructions. we will not accept liability for any damage or injury caused by misuse or non compliance with instructions and safety procedures.
- b. This instrument must not be used on live circuits. Ensure all circuits are de-energised before testing. see paragraph for details of built-in warning features should your high voltage insulation tester be connected to a live system.
- c. Always inspect your high voltage insulation tester and test leads before use for any sign of abnormality or damage. If any abnormal conditions exist (broken test leads, cracked case, display faulty etc...) do not attempt to take any measurement or use the tester. Return your high voltage insulation tester to your nearest distributor for service.
- d. Your high voltage insulation tester has been designed with your safety in mind. However, no design can completely protect against incorrect use. Electrical circuits can be dangerous and / or lethal when a lack of caution or poor safety practice is used.
- e. Pay attention to cautions and warnings which will inform you of potentially dangerous procedures.
- f. Your high voltage insulation tester has a live circuit warning beeper. If it is connected to a live circuit, a rapid pulsating bleep will be heard. **DO NOT** proceed to test and immediately disconnect the instrument from the circuit. In addition your tester will display the warning message.

g. Rated environmental conditions :

- (1) Indoor use.
- (2) Installation Category IV.
- (3) Pollution Degree 2.
- (4) Altitude up to 2000 meters.
- (5) Relative humidity 80% max.
- (6) Ambient temperature 0°C~40°C.

h. Observe the international Electrical Symbols listed below :



Meter is protected throughout by double insulation or reinforced insulation.



Warning ! Risk of electric shock.



Caution ! Refer to this manual before using the meter.



Earth

2. Overview

This is a 5kV high voltage insulation tester which has output voltages of 500V, 1000V, 2500V, 5000V.

The top line of the display shows the elapsed time at the start of the test. Digital readout of the total time will remain displayed even after testing has ceased.

This instrument displays a voltage warning and sounds when AC or DC is present before injecting the test voltage.

3. Features

- High contrast OLED display
- Microprocessor-controlled
- Tests insulation resistance up to 10 TΩ
- 4 Insulation test voltages:
500V, 1000V, 2500V, 5000V
- AC/DC Voltmeter
- Short-circuit current up to 5mA
- PI (Polarization Index) indication
- DAR (Dielectric Absorption Ratio) indication
- Auto-ranging on all insulation ranges
- Optical USB to RS-232 data transmission
- Well isolated from contact
- Well protected from surges
- 2 built-in optical LEDs for data transfer
- Visual and audio warning of external voltage presence
(≥30Vac or ≥30Vdc)
- Auto-hold function to freeze reading
- Overload protection
- Adjustable testing duration: 1~30 minutes
- Internal memory for data storage
- Displays testing duration for insulation measurement
- Auto-off function
- 200 measurement results can be saved in memory and recalled on display

4. Specifications

Test Voltage	500V, 1000V, 2500V, 5000V	
Insulation resistance	1TΩ / 500V 2TΩ / 1000V 5TΩ / 2500V 10TΩ / 5000V	
Accuracy	0~100GΩ / 500V 0~200GΩ / 1000V 0~500GΩ / 2500V 0~1000GΩ / 5000V	±(5.0%rdg + 5dgt)
	100G~1TΩ / 500V 200G~2TΩ / 1000V 500G~5TΩ / 2500V 1000G~10TΩ / 5000V	±12%rdg
Resolution	1000MΩ: 1MΩ 10GΩ: 0.01GΩ 100GΩ: 0.1GΩ 1TΩ: 1GΩ 10TΩ: 10GΩ	
Short circuit current	up to 5mA	
PI (Polarization Index)	√	
DAR (Dielectric Absorption Ratio)	√	
Voltmeter	ACV: 30~600V DCV: 30~600V Accuracy: ±(2.0%rdg + 3dgt) Resolution: 1V	
Current measurement	0.5nA ~ 0.55mA (Depending on the insulation resistance)	
Power source	Rechargeable battery	
Adapter	Input: 100-240Vac, 0.4A, 50-60Hz Output: 24Vdc, 0.62A	
Dimensions	330(L) × 260(W) × 160(D)mm	
Weight	Approx. 3760g	
Safety standard	EN 61010-1 CAT IV 600V EN 61010-2-030 EN 61326-1	
Accessories	Instruction manual Test leads Data transmission cable CA-232 Compact disk (CD) for PC interface Alligator clip Charger Test report	

5. Connections

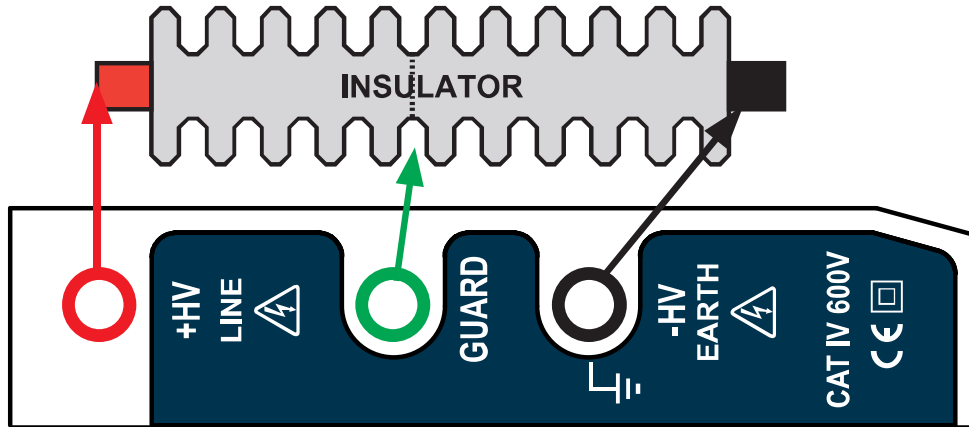

FIRST MEASUREMENT

MEASURE WITHOUT THE GUARD TO TAKE EVERYTHING INTO ACCOUNT AND FIND OUT IF NEED CLEANING.

DIRTY INSULATOR ELECTRICAL EQUIVALENT CIRCUIT DIRTY INSULATOR

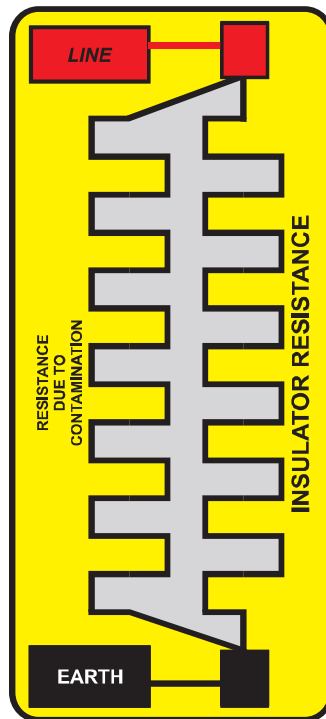
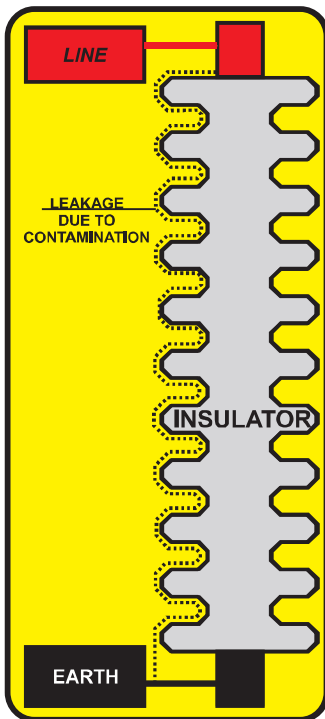

SECOND MEASUREMENT

MEASURE WITH THE GUARD TO ENSURE INSULATOR IS CORRECT.

TYPICAL TEST

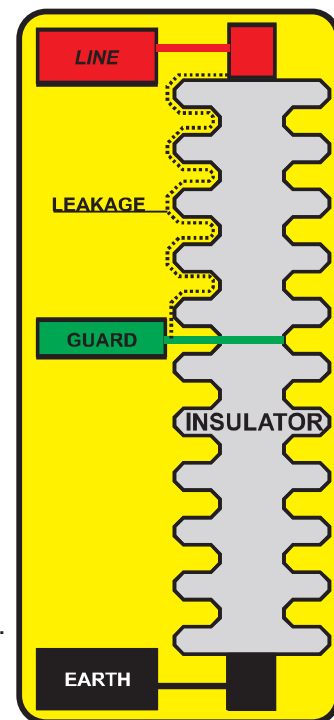

RESISTANCE DUE TO CONTAMINATION CAN BE VERY LOW AND LOWER THE TOTAL RESISTANCE. CLEANING PERIODICALLY CAN ALSO REDUCE SYSTEM POWER CONSUMPTION.

6. Instrument layout

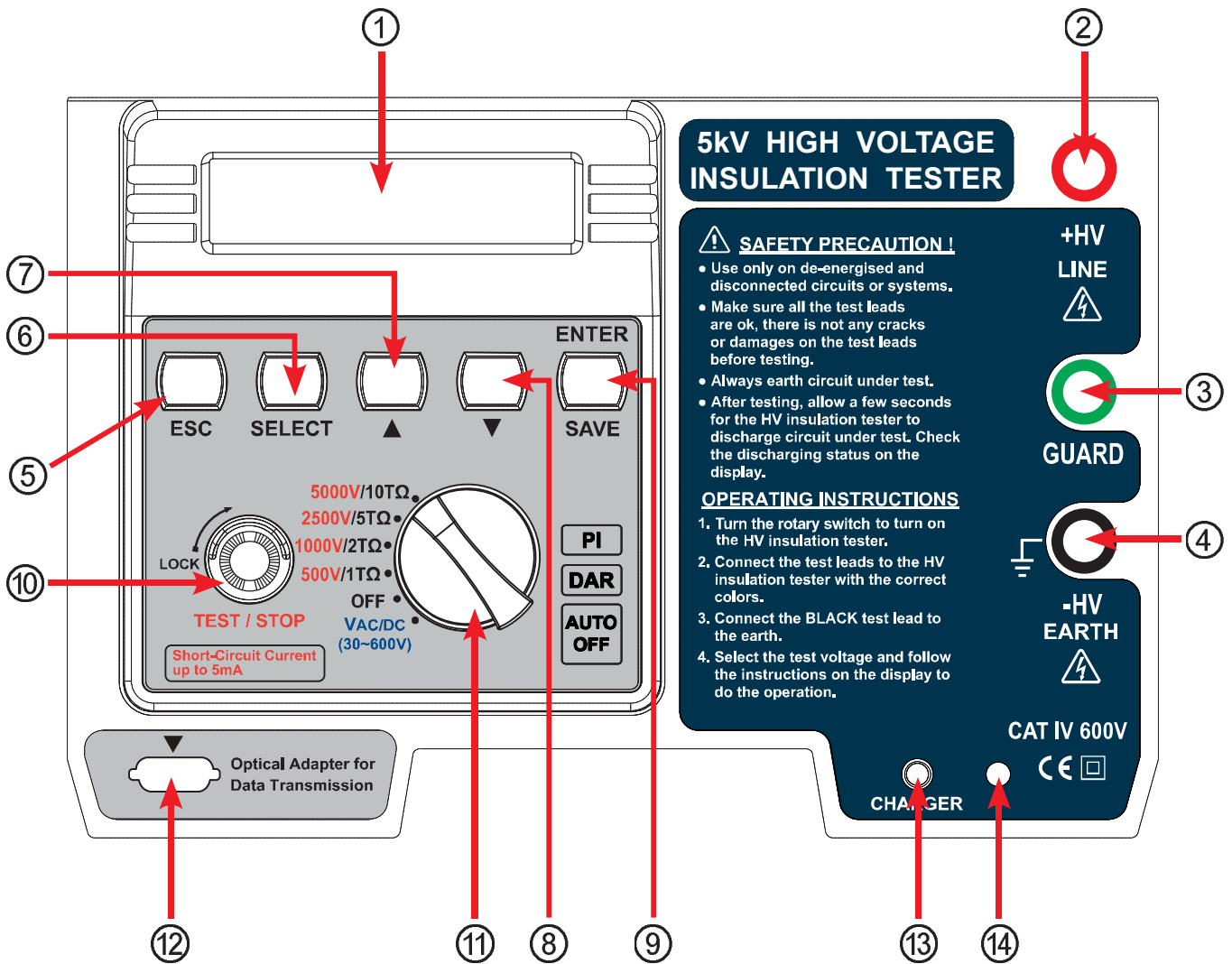

- | | |
|------------------------------|---|
| ① High contrast OLED display | ⑨ ENTER / SAVE button |
| ② +HV terminal | ⑩ TEST / STOP button |
| ③ GUARD terminal | ⑪ Function rotary switch |
| ④ -HV terminal | ⑫ Connection socket for data transmission |
| ⑤ ESC button | ⑬ Battery-charge socket |
| ⑥ SELECT button | ⑭ LED charge indicator |
| ⑦ "▲" button | |
| ⑧ "▼" button | |

7. Measuring procedure

This tester provide five main functions and four minor functions:

Main Functions:

1. 500V voltage insulation resistance test.
2. 1kV voltage insulation resistance test.
3. 2.5kV voltage insulation resistance test.
4. 5kV voltage insulation resistance test.
5. AC/DC voltage measurement.

Minor functions:

Function 1 — Date/time adjustment.

Function 2 — Measurement time setting.

Function 3 — Display data stored.

Function 4 — Delete data stored.

(A) Insulation resistance measurement test (main function)

⚠ Note:

1. Before test performed, be sure that no voltage is made on the specimen. If voltage exists therein, remove the power supplied.
 2. To secure operator's safety, check if there is any damage on the tester or test cable.
 3. During the test, do not touch the metal on the specimen surface or test cable.
 4. Wear insulation gloves and rubber shoes while operating this high-voltage measuring instrument.
- (a) Checks before test is performed:
Press the power switch and check if power supply is sufficient? If insufficient, "Low Battery" will be displayed on the LCD display. Charge the battery before making measurement.

(b) Measuring procedure:

1. Connect specimen by test cable.

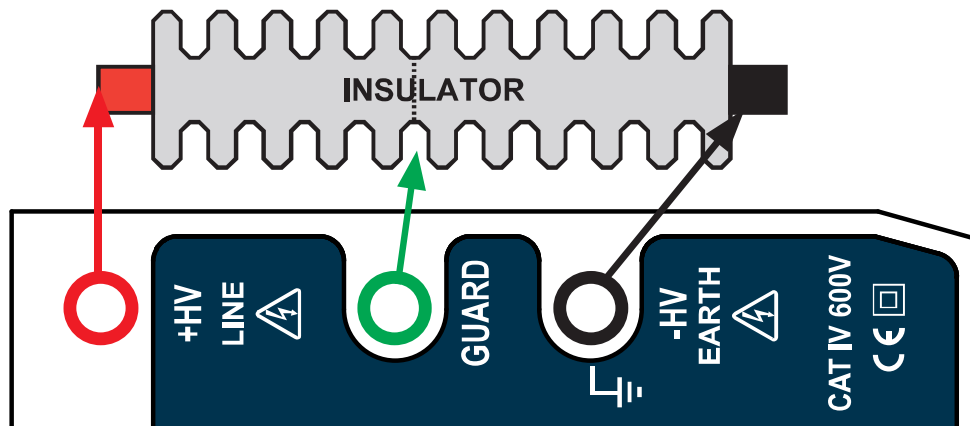

2. Switch $\text{\textcircled{11}}$ the function rotary switch to turn on power and select test voltage from 500V, 1kV, 2.5kV or 5kV, respectively.
3. Be sure that the cable connecting the specimen, if there is a exterior voltage (above AC30V or DC30V) exerted, beeper activates in response; and LCD displays the warning picture as shown in the AC/DC voltage measurement function:

```
2016-08-16 10:10
ACV 110V 60HZ
```

Now, test cannot be performed. To go on the test it should remove the exterior voltage.

4. Then, press $\text{\textcircled{10}}$ TEST / STOP button to test.
 - (1) Rotate another angle to lock $\text{\textcircled{10}}$ TEST / STOP button for testing continuously.
 - (2) While test is running, beeper activates to remind operator that test is underway.
 - (3) After the set test time is due (see Function 2: the test time setting), test stops and system will automatically lock down the test value.
 - (4) To read the test value on the LCD display

5. Read the test value from LCD display.
6. To store the data, press ⑨ (ENTER/SAVE); LCD displays the picture shown in below:



003 545V/0.5KV
891G 00:35

⚠ Note:

When do the insulation test, always connect the test leads to the object we want to measure before pressing the TEST button.
Do not press the TEST button in advance.

(B) Measure voltage (Voltage Meter) —(main function)

1. Switch ⑪ the function rotary switch to turn on power and select AC/DC voltage measurement.



2016-08-16 10:10
ACV 110V 60HZ

2. Read the data measured from LCD display.



2016-08-16 10:10
TOhm 5KV/10TΩ

(C) Date/time adjustment (RTC Adjustment) – Function 1

1. Switch ⑪ the function rotary switch to turn on power and no meter which function selected (Main page)
2. Press ⑥ SELECT button to enter the minor function selection, LCD display the following pictures respectively:



Function Select
1.Date/Time ADJ

3. Press ⑨ (ENTER/SAVE) button to enter the Date/Time Adjustment .
4. Press ⑥ SELECT button to select year, month, day, hour or minute for adjustment, LCD display the following pictures respectively:



2016-10-10 10:10
UP DOWN SAVE

5. Press ⑦ (value-add) "up" or ⑧ (value-reduce) "down" till the correct value is reached.
6. After all adjustments are complete, press ⑨ (ENTER/SAVE) to confirm and save the data measured.
- ⚠ Note: if Date/Time unit (year, month, day, hour or minute) needs not to be adjusted, press ⑩ (ESC) to skip it and return back to the minor function selection.
7. Press ⑩ (ESC) again to return back to the main page.

(D) Measurement time setting (Test Timer) – Function 2

1. Switch ⑪ the function rotary switch to turn on power and no meter which function selected (Main page)
2. Press ⑥ SELECT button to enter the minor function selection.
3. Press ⑦ (value-add) "up" or ⑧ (value-reduce) "down" to find the measurement time setting, LCD display the following pictures respectively:



Function Select
2. Test Timer

4. Press ⑨ (ENTER/SAVE), LCD displays the picture shown in below:



Test Timer
10 minutes

5. Press ⑦ (value-add) "up" or ⑧ (value-reduce) "down" to set the test Time (form 1 to 30 minutes).
6. After setting is complete, press ⑨ (ENTER/SAVE) to confirm & save the data measured.
- ⚠ Note: if Test Timer unit needs not to be adjusted, press ⑩ (ESC) to skip it and return back to the minor function selection.
7. Press ⑩ (ESC) again to return back to the main page.

(E) Display the data stored (LDG Display) – Function 3

1. Switch ⑪ the function rotary switch to turn on power and no meter which function selected (Main page)
2. Press ⑥ SELECT button to enter the minor function selection.
3. Press ⑦ (value-add) "up" or ⑧ (value-reduce) "down" to find the displaying of data stored, LCD display the following pictures respectively:



```
Function Select
3.LOG DISPLAY
```

4. Press ⑨ (ENTER/SAVE), LCD displays the picture shown in below:



```
001 5500V/5.0KV
899G 00:03
```

5. Press ⑨ (ENTER/SAVE) to query the subpage of data (include Resistance value, testing voltage, PI, DAR, Saving Date & Time).
6. Press ⑦ (value-add) "up" or ⑧ (value-reduce) "down" to select the required data value. If no data available, LCD displays the picture shown in below:



```
LOG SHOW 000/000
There is no LOG.
```

7. After the query is over, press ⑩ (ESC) return back to the minor function selection.
8. Press ⑩ (ESC) again to return back to the main page.

(F) Clear/Erase the data stored (LOG Clear) – Function 4

1. Switch ⑪ the function rotary switch to turn on power and no meter which function selected (Main page)
2. Press ⑥ SELECT button to enter the minor function selection.
3. Press ⑦ (value-add) "up" or ⑧ (value-reduce) "down" to find the Erasing of data stored, LCD display the following pictures respectively:



```
Function Select
4.LOG CLEAR
```

4. Press ⑨ (ENTER/SAVE) to inquire whether to clear up the data or not; LCD displays the picture shown in below:



```
Clear 002 loss
Are you sure ?
```

Note: if the erasing unit needs not to be done, press ⑩ (ESC) to skip it and return back to the minor function selection.

5. Press ⑨ (ENTER/SAVE) again to clear up the data ; LCD displays the picture shown in below:



```
Clear 002 loss
Completely !!
```

, then return back to the minor function selection.

6. Press ⑩ (ESC) to return back to the main page.

(G) Introduction of other functions

1. Dielectric absorption ratio (DAR):

Ratio of insulation resistance between 1-min and 30-sec

$$\text{DAR} : \frac{\text{1-min insulation resistance}}{\text{30-sec insulation resistance}}$$

2. Polarization index (PI):

Ratio of insulation resistance between 10-min and 1-min

$$\text{PI} : \frac{\text{10-min insulation resistance}}{\text{1-min insulation resistance}}$$

Lower insulation resistance tested takes longer test time, which would deteriorate the specimen. Thus, higher DAR or PI (as close to 1) would create better insulation grade of specimen.

⚠ Operation:

During the test run, wait for one minute, DAR will be displayed automatically; wait for 10 minutes, PI will be displayed automatically.

3. AUTO OFF:

System will shutdown automatically after 3 minutes without operation.

8. Charge

(A) Timing:

After "Low Battery" is displayed on LCD display, perform battery charge; LCD displays the picture shown in below:



Batt. Low 10:10

(B) Process:

1. Plug one end of charger into the battery-change socket and the other end into the ACV power socket.
2. If ACV plug socket is energized, the LED charge indicator is lit on indicating that charge is underway. If the ACV plug socket isn't energized, remove to another power-energized one making power charge.
3. After the voltage reaches 12.6V, charge process is complete. (It can be observed on LCD display.)

⚠ No measurement can be performed during the charging process.

9. Maintenance & repair

- (A) To avoid and electric-shock or device damage, do not wet inner part of the tester.
- (B) Avoid the tester from being dropped down that would damage or disconnect devices apart.
- (C) Wipe the tester surface with soft, dry cloth and mild detergent. Prohibit from using sand paper or solvent.

⚠ Note:

1. This tester is HV operated; user should not open the outer casing. If any damage occurs, take the tester back to manufacturer for repair.
2. If the tester isn't under operation for a long period, charge it at least once per month as to protect the battery from being deteriorated.

10. Data Transmission Interface connection and operation

(A) 5KV Insulation Tester Installation Steps:

1. This 5KV Insulation Tester Installation program will be installed on the computer automatically.



2. Click the "Next" key to set.

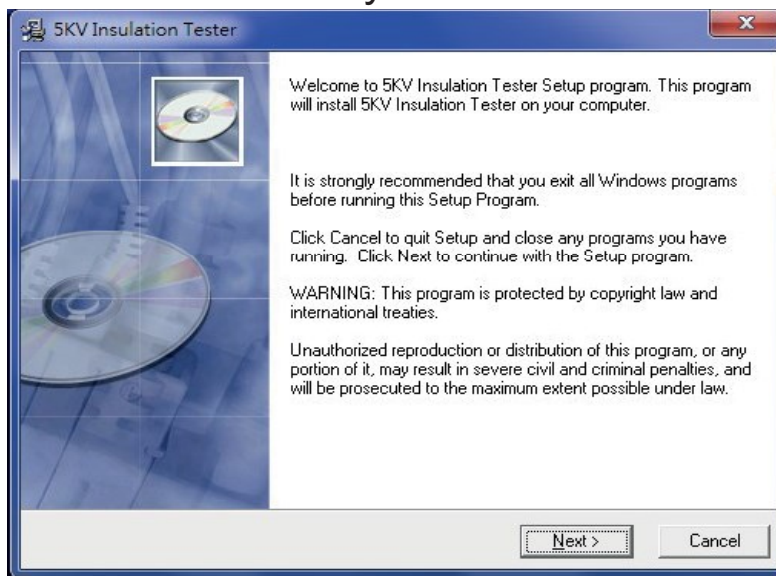

3. If you want to install a different folder, click Browse, and select another folder.

If it's not necessary, click the "Next" key.

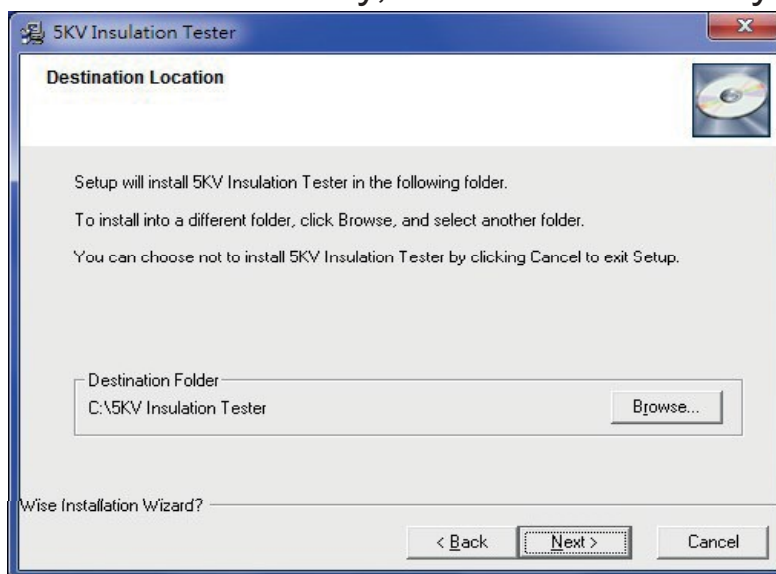

4. Click the “Next” key.

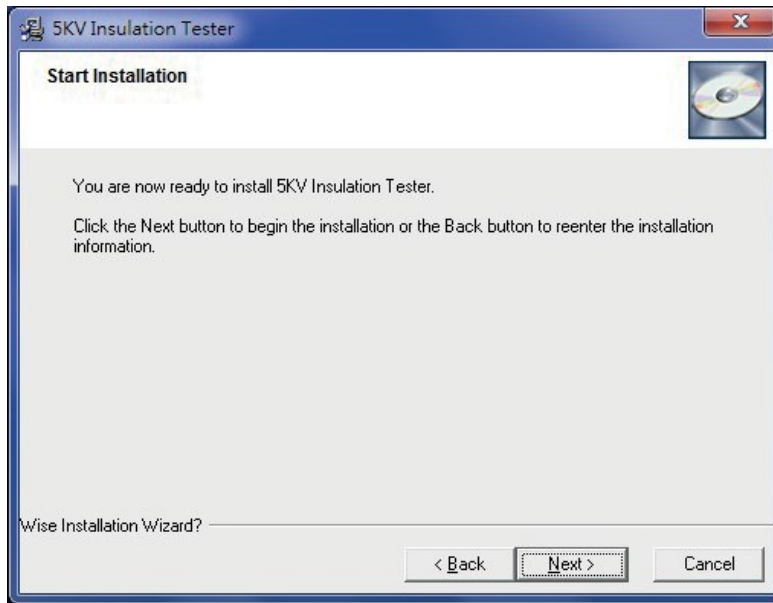

5. It will show the information of all files are Installing to your personal computer.

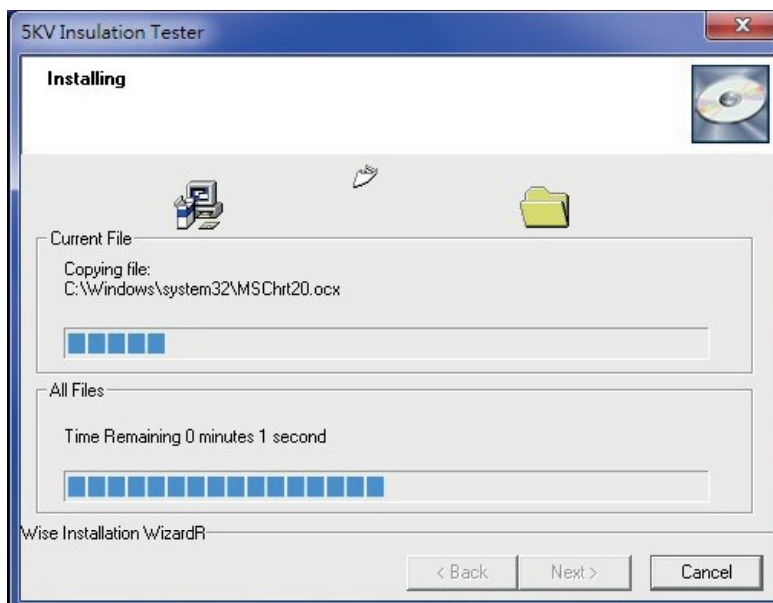

6. It will show the information of Insulation tester has been successfully installed and then click “Finish” key.

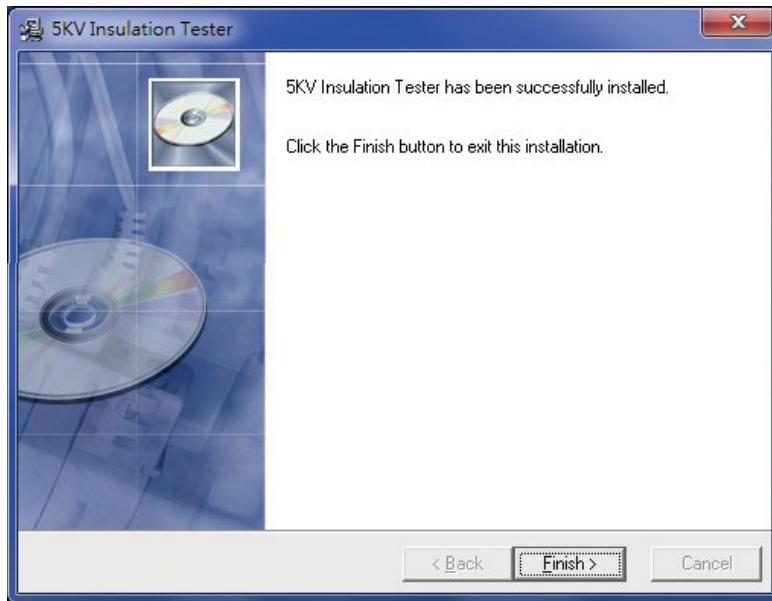

(Note: If your personal computer system is Windows 7, it will indicate the driver automatically. It's necessary to install the driver if your computer system is not windows 7, then the driver is in the compact disk (CD). The directory is " E:USB DRIVER/CDM 2.08.24 WHQL Certified x 86-32 bit".)

(B) Windows Comm Port setting:

1. Plug data transmission cable into your personal computer USB port.
2. On your windows, click the “” key and find the “Control Panel” Application.

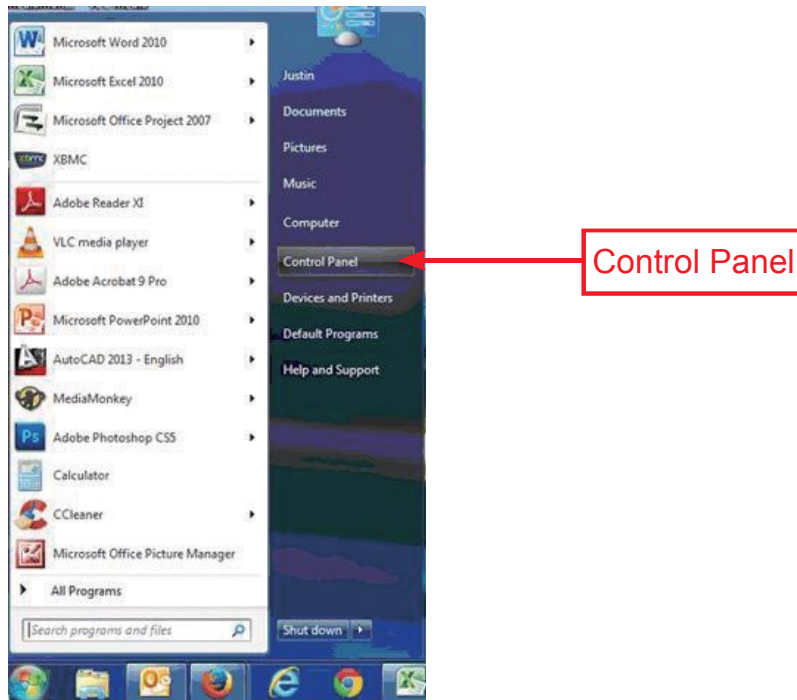

3. On the Control Panel Application, find the “ Hardware and Sound” Application.



4. On the Hardware and Sound Application, find “Device Manager” Application.

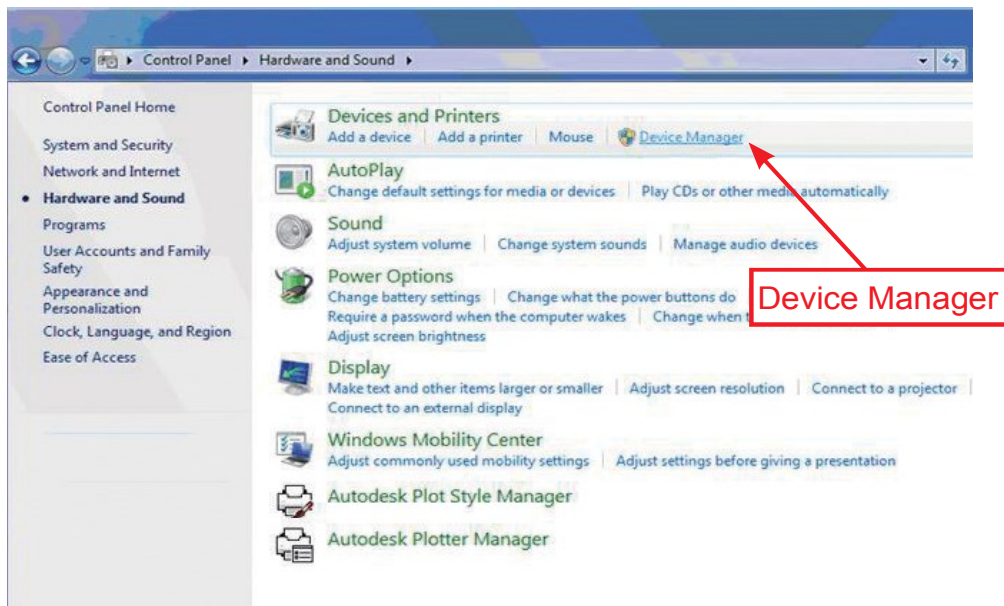

5. On the Device Manger Application, click right button of the mouse and find “Universal Serial Bus Controllers”
6. On the Universal Serial Bus Controllers, Find the USB Serial Port (COM 3)

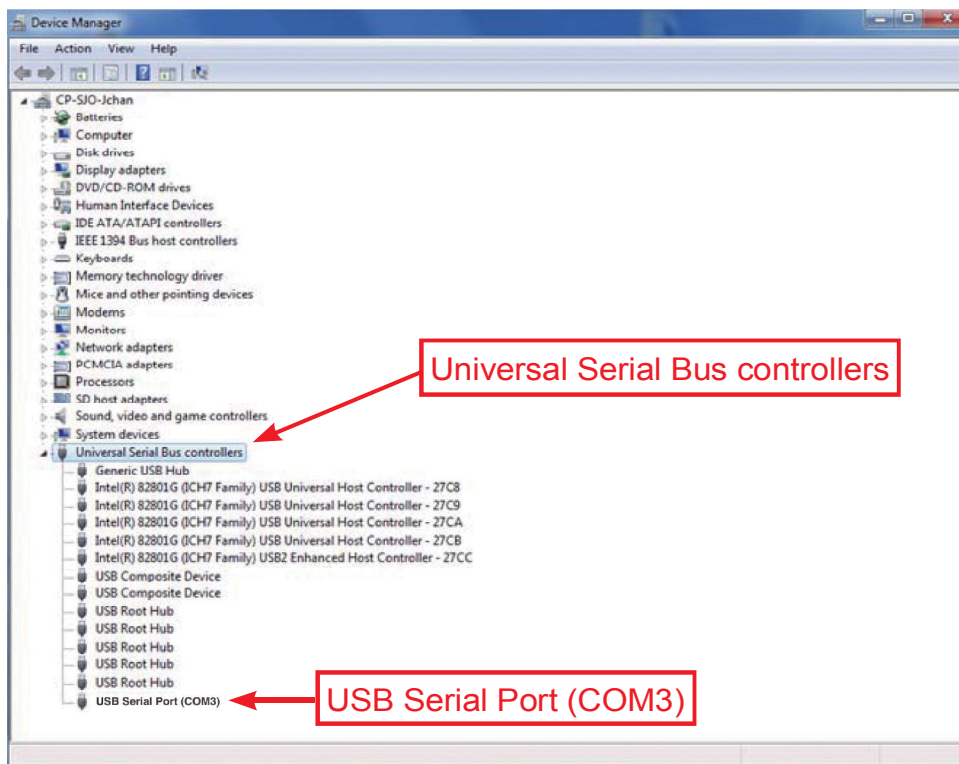

(Note: USB Serial Port will indicate different “COM” automatically)

(C) 5KV Insulation Tester Software Comm Port setting:

1. Connect data transmission cable to the Insulation Tester.
2. Click the icon of the “5KV Insulation Tester” on your desktop of your personal computer.



3. On the 5KV Insulation Tester Windows, select the correct “Comm Port” and click the RS 232 connection button.

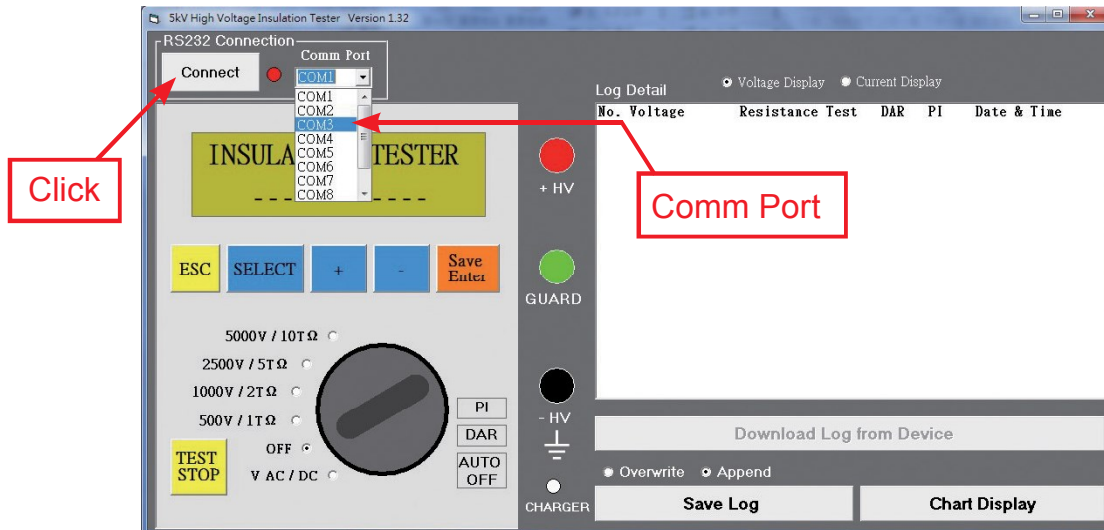

(D) 5KV Insulation Tester Interface Layout:

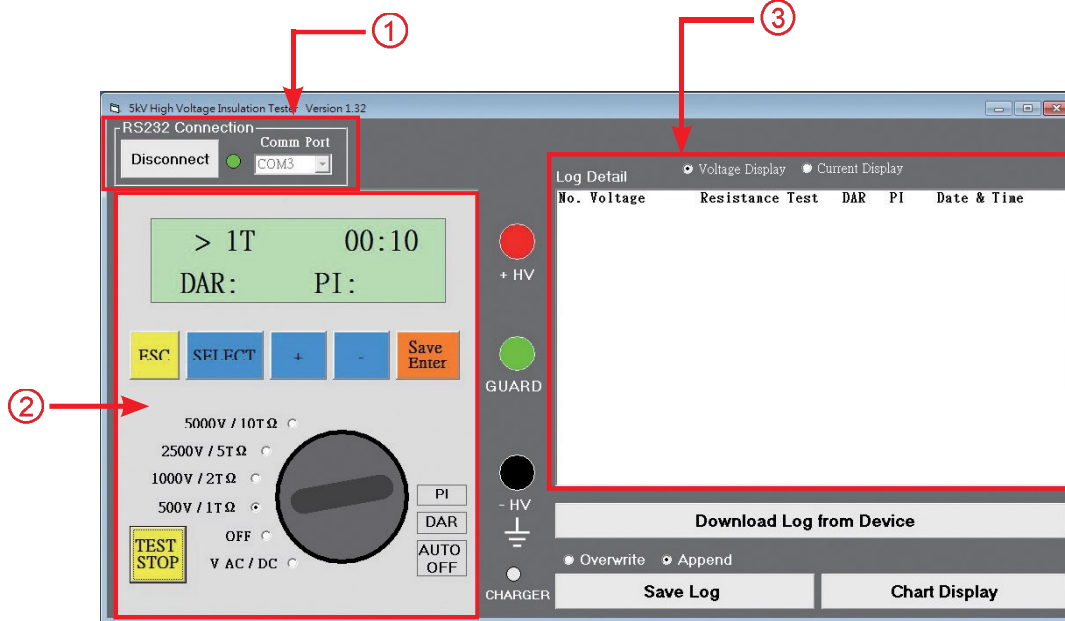

- ① RS 232 Connection.
- ② Main operation interface.
- ③ Memory saving and downloading interface.

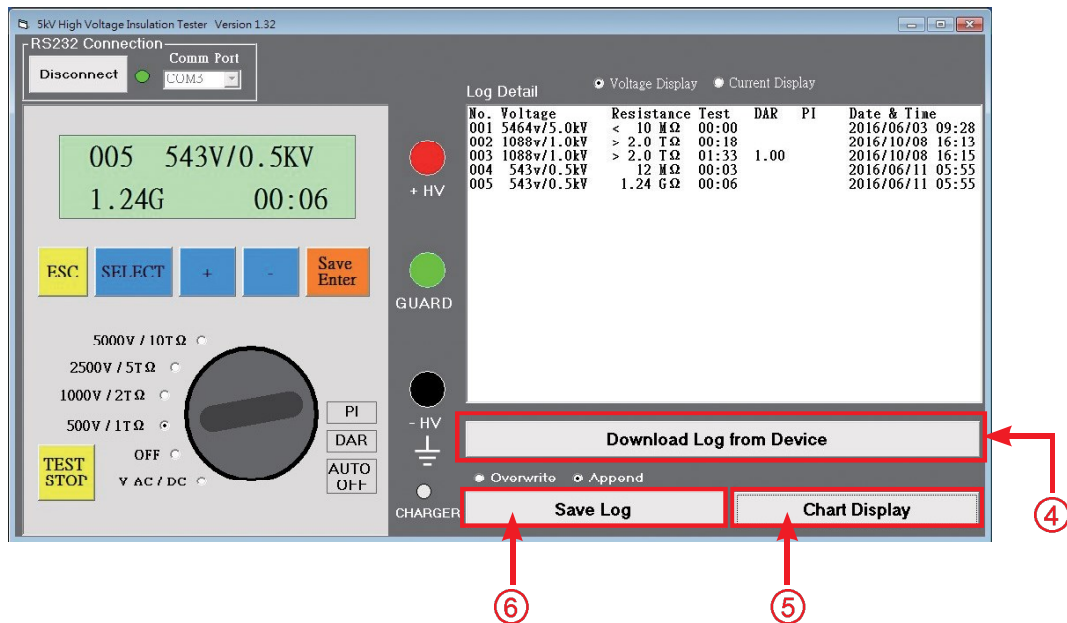

- ④ Click the "Download Log from Device" button to download the current data and statistics files.

- ⑤ Click the "Chart Display" button to see the chart, as the figure is below:

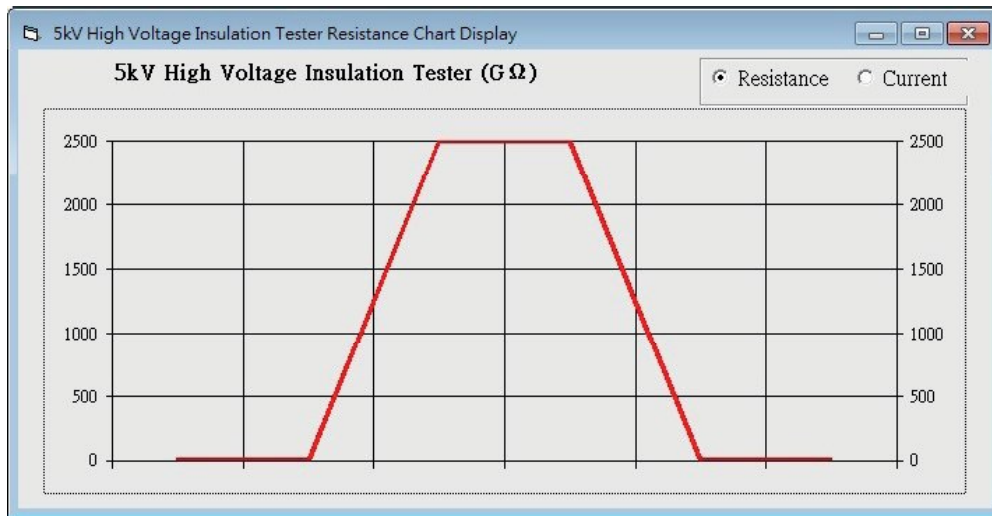

This Chart Display can also show Resistance and Current diagram by clicking the dot

- ⑥ Click the "Save Log" button to the file, as the figure is below:

No.	Voltage	Value	Test	DAR	PI	Date & Time
001	5464v/5.0kV	< 10 MΩ	00:00			2016/06/03 09:28
002	1088v/1.0kV	> 2.0 TΩ	00:18			2016/10/08 16:13
003	1088v/1.0kV	> 2.0 TΩ	01:33		1.00	2016/10/08 16:15
004	543v/0.5kV	12 MΩ	00:03			2016/06/11 05:55
005	543v/0.5kV	1.24 GΩ	00:06			2016/06/11 05:55