

MACHRUS
UPPERBOUNCE®

EASY ASSEMBLE/DISASSEMBLE
TRAMPOLINE
USER MANUAL

ASSEMBLY, INSTALLATION, CARE, MAINTENANCE AND USE INSTRUCTIONS.

! **WARNING:** READ THESE MATERIALS PRIOR TO ASSEMBLING AND USING THIS TRAMPOLINE.

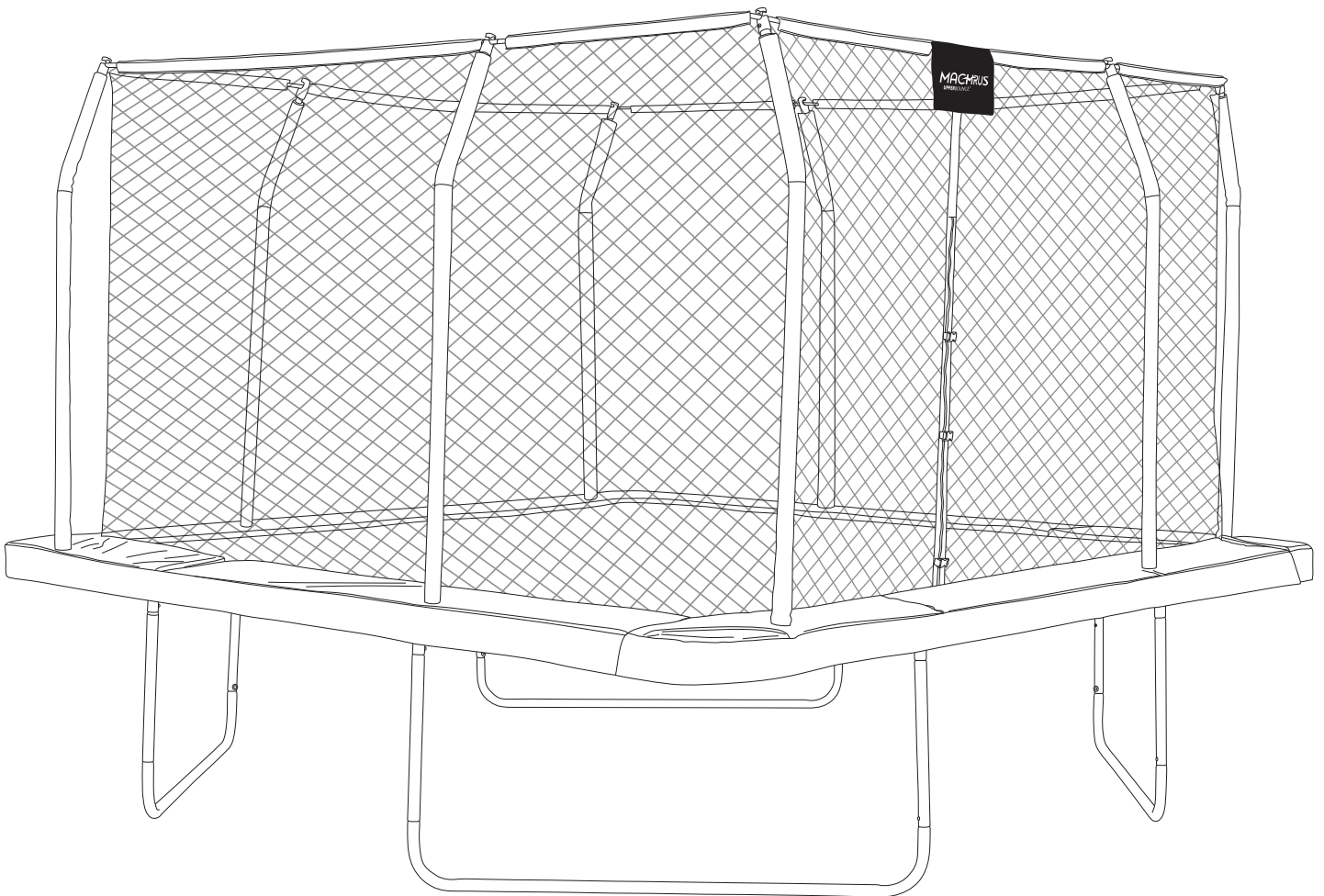

MODEL#

UBSQ01-12-BG | UBSQ01-12-OB

UBSQ01-16-BG | UBSQ01-16-OB

MACHRUS

LET'S GO OUT AND PLAY!

📍 2 MILL ST. CORNWALL NY 12518

🌐 www.machrus.com



USA

UK



CALL US

| -888-965-333 |

020-3150-0484



EMAIL US

support@machrus.com

support@machrus.co.uk



CHECK OUT OUR
WEBSITE

WWW.**MACHRUS**.COM

Thank you

thanks for purchasing this Machrus trampoline part

Simply follow the assembly and safety instructions in this manual and you will soon be starting your **Machrus** exercise program for a happier, healthier lifestyle and fun!

Should you have any questions, please call our Customer Service Department

Toll-free number: 1-888-965-333 |

MONDAY - THURSDAY

9:30 AM - 5:00 PM
Eastern Time

FRIDAY

9:00 AM - 12:00 PM
Eastern Time

TABLE OF CONTENTS

Introduction, Guidelines, Additional Tips, Warnings	3-7
Trampoline Frame Parts List	8
Overall Parts with Item Code	9
Trampoline Frame Assemble	10-11
Trampoline Mat Assembly	12
Trampoline Pad Assemble	13
Enclosure Set Parts List	14
Enclosure Set Assemble	15-16
Enclosure Set Disassembly	17
Testing the Trampoline	18
Fundamental Bounce Techniques	19
Replacement Parts List	20

INTRODUCTION

Before you begin to use this trampoline, you must read all the information in this manual. Just like in any other type of physical recreational activity, participants can be injured. To reduce the risk of injury, please carefully read and follow the appropriate safety rules and tips.

Misuse and abuse of this trampoline is dangerous and can cause serious injury!

Trampolines are rebounding devices which propel the performer to unaccustomed heights through a variety of movements. So always use caution when playing on a trampoline.

Always inspect the trampoline before each use.

Proper assembly, care and maintenance of product, safety tips, warnings and proper techniques in jumping and bouncing are included in this manual. All users and supervisors must read and familiarize themselves with these instructions. Anybody who chooses to use this trampoline must be aware of their own limitations in regards to performing various jumps and bounces with this trampoline.

Initially, you should get accustomed to the feel and bounce of the trampoline. The focus must be on your body position and you should practice each fundamental bounce until you can do each skill with bounce before moving on to more difficult and advanced bounces. Do not behave recklessly on the trampoline, emphasis must be made on good control and the mastering of various bounce techniques.

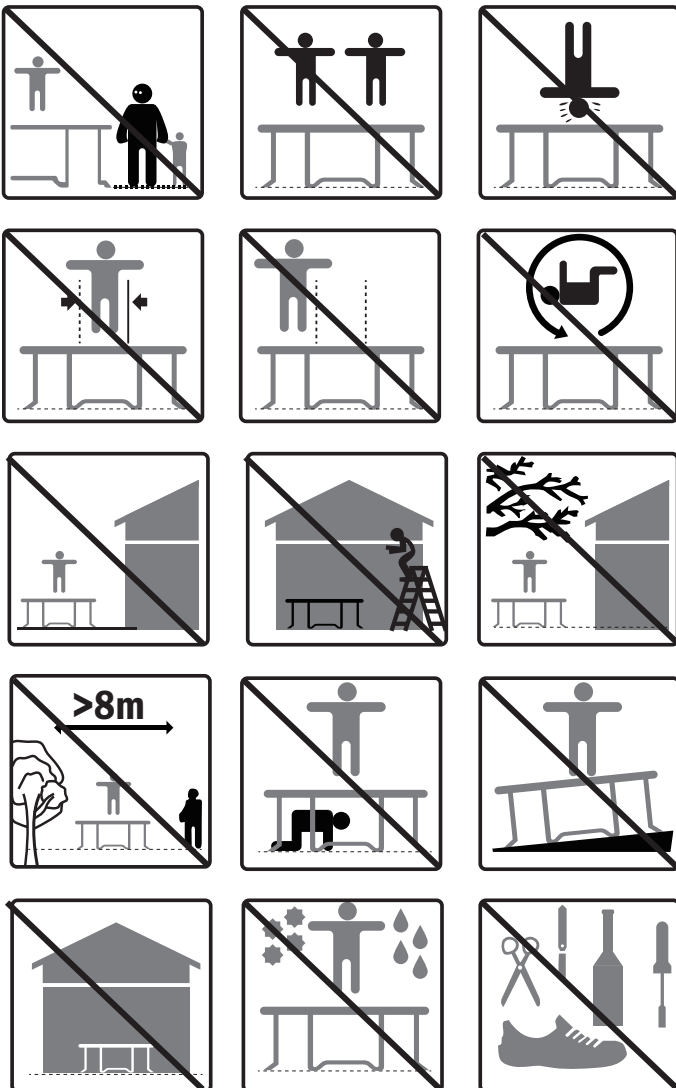

No more than one person is allowed on the trampoline! Multiple jumpers increase the risk of mid-air collisions resulting in injury.

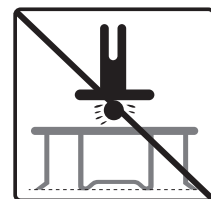

Do not perform somersaults (flips) as this will increase the chances of landing on your head or neck. Paralysis or even death can result.

TRAMPOLINE GUIDELINES

I. GENERAL INSTRUCTIONS

I.1 Purpose

- The product is intended for home/domestic use only and is not suitable for professional or medical uses.
- The maximum weight is 400 lbs. Overloading the trampoline above the recommended user weight will cause damage to the trampoline which is not covered by warranty.

I.2 Danger for children

- Do not let unsupervised children near this product. Carry out the necessary safety precautions and supervise all trampoline activities. Be aware that the packaging material is not suitable for children. There is a danger of suffocation!
- Trampolines over 51 cm (20 inches) in height are not recommended for children under 6 years of age. Children do not recognize potential dangers of this product. Keep children away from this product, it is not a toy. The product has to be stored out of reach of children and pets.

I.3 Attention - Product Damages

- Do not alter the product. Only use original spare parts. Repairs should only be carried out by qualified technicians. Improper repairs can compromise the safety of your trampoline. Use this product only as described in this manual.
- Protect the product against humidity and high temperatures.

I.4 Advice for the assembly

- The assembly of the product must be done carefully by at least two able-bodied adults. If in any doubt, ask a technically qualified person.
- Before you start assembling the trampoline, read all the instructions in this manual.
- Remove all packaging materials and lay down all parts on a free space. This gives you an overview and simplifies the assembly procedure.
- Confirm that all parts are present. Dispose of the packaging material when the assembly is completed.
- Beware that when using tools or doing technical work there is always a risk of injury, therefore assemble the product carefully.
- Create a danger free environment, for example: Do not leave tools scattered around the workspace.
- Store the packaging material in a way that cannot cause any danger. Foils and plastic bags are dangerous for children (danger of suffocation!)

TRAMPOLINE GUIDELINES (Cont.)

- After installing the product according to the instruction manual, please make sure that all screws, bolts and nuts are correctly installed and tightened and that all joints are tightly fixed.
- A clearance space of at least 7.3m is necessary above the trampoline. An appropriated clearance must be kept between the trampoline and possible sources of danger, such as electric cable, tree branches, playing devices, swimming pools and fences.
- The trampoline must be set up properly before use.
- Never set up the trampoline in rainy, windy or stormy conditions. Especially lightening conditions. It is recommended that the trampoline be taken apart and stored in bad weather.
- The metal frame of the trampoline will conduct electricity, lighting, extension cords and all electrical equipment must never be allowed to come in contact with the trampoline.
- The trampoline must not be used in the vicinity of other leisure devices and constructions.
- When assembling or disassembling, please use gloves to protect your hands.

Additional Tips

- For additional stability you can place sand bags on the trampoline legs. This will prevent the trampoline from tipping over in the event of any sideward force.
- Do not use during pregnancy.
- Do not use when suffering from high blood pressure.
- Do not wear shoes while jumping. This will damage the jumping mat which is not covered by the warranty.
- No smoking.
- Do not put cigarettes, pets, sharp objects or any other foreign objects on the trampolines.
- Do not use the trampoline when under the influence of alcohol or drugs.
- Do not sit or lean on the cover pad as it needs to be flexible so it can move with the mat. Please do not allow small children to pull themselves up onto the trampoline by using the cover pads. Tears in stitching caused by obstructing frame pads are not covered by warranty.
- Place trampoline on level ground. Preferably on grass. Locating the trampoline on a hard surface will add stress to the frame and over time cause damage which is not covered by the warranty. Placing the trampoline on uneven surfaces may result in the trampoline tipping over.
- Do not expose the trampoline to direct contact with open flames.
- Secure the trampoline against unauthorized use.
- Do not use if trampoline is wet.
- Trampoline should be tied down with anchors during windy conditions or disassembled and stored away.

TRAMPOLINE GUIDELINES (Cont.)



WARNING:

1. Please ensure that the safety enclosure net zipper is 100% closed and all three entrance clips are closed before jumping.
2. Do not intentionally jump into the safety net, it is only designed to stop persons from falling off the trampoline. Intentional jumping into the safety net may cause the trampoline to topple over, or may damage your net. Abuse of the safety net is considered negligent use which is not covered by the warranty, please refer to the disclaimer.

2. SAFETY INSTRUCTIONS FOR TRAMPOLINES











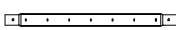
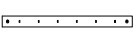
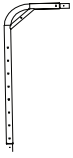

- All users of the trampoline need a supervisor. Regardless of the age or experience of the user.
- The safety instructions of the trampoline should always be considered and obeyed.
- Somersaults should be avoided. Incorrect landings on the trampoline can lead to injuries, particularly to the back, neck or head. Injuries may include paralysis, or even death.
- Only one person should use the trampoline at a time. Multiple users on the trampoline will increase the risk of collision.
- The trampoline has to be examined for damaged, wearing or defective parts before each usage, as they can impair the overall safety of the trampoline. The damaged, worn or defective parts should be replaced immediately. In the meantime the trampoline must be restricted from access.
- No clothes with hooks or parts may be carried when jumping on the trampoline, in order to avoid hooks getting caught.
- The trampoline must be set up only on a flat ground and non-slippery surfaces.
- Strong winds can blow the trampoline away. If strong winds are predicted, the trampoline must be moved to a protected place and taken apart, or fastened to the ground with cords and moorings.
- Try to avoid moving the assembled trampoline, it could bend during transportation. Should it be necessary to move the trampoline, please consider the following: at least four people must be evenly spaced around frame to lift the trampoline off the ground. The trampoline must be carried horizontally, and if the frame shifts position use four people to draw the trampoline into shape.
- Trampolines are jumping devices, enabling the user to jump to unusual heights as well as into a multiplicity of body movements. Jumping into the trampoline, hitting the frame or cover pads, and landing incorrectly on the trampoline, can lead to injury.

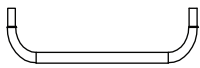
TRAMPOLINE GUIDELINES (Cont.)

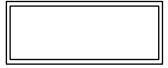

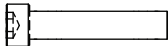







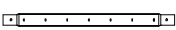
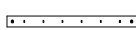



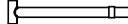

- Users should be familiar with the user manual. This manual contains assembly instructions and selected precautionary measures as well as recommendations for servicing and maintenance of the trampoline, in order to ensure a secured and fun use of the trampoline.
- It is the responsibility of the owner or the supervisor to guarantee that all users of the trampoline are informed about all safety rules and that there is sufficient space around the trampoline as a safety precaution.
- Never place the trampoline near water, and keep sufficient space around it as a safety precaution.
- Beware of moving parts which could catch your arms and legs.
- Do not stick any foreign objects into the trampoline.
- Do not allow anyone or any object to go under the trampoline while someone is jumping on the mat. The jumping mat is flexible and the downward force created by someone jumping can cause serious injuries.
- Implement all safety rules and make yourself familiar with the information in the user manual.
- The trampoline can only be used if the jumping mat is clean and dry. Worn or damaged jumping mats should immediately be replaced.
- Objects that could be dangerous should be vacated from the area.
- Avoid unsupervised use of the trampoline.
- Do not use the trampoline under influence of alcohol or drugs (incl. medication).
- Learn the Fundamental Bounce Techniques thoroughly. Before trying difficult jumps, see section fundamental bounce Techniques.
- Carefully climb onto trampoline. Do not jump into it directly. Do not use the trampoline as a jump board for other articles.
- For further information or exercise instructions, you can turn to a trained trampoline teacher.

TRAMPOLINE PARTS LIST

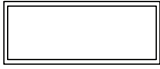
UBSQ01-12

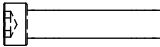
ITEM	PART IMAGE	MODEL	QTY.	SKU #
A		TOP RAIL A	4	UBRP-SQ01-TRA-12
B		TOP RAIL B	4	UBRP-SQ01-TRB-12
C		CORNER TUBE	4	UBRP-SQ01-CTC1-12
D		T-BAR STYLE 1	4	UBRP-SQ01-DTBAR1
E		T-BAR STYLE 2	4	UBRP-SQ01-ETBAR2
F		T-BAR STYLE 3	4	UBRP-SQ01-FTBAR3-12
G		LEG EXTENSION	8	UBRP-SQ01-LEGEX-12
H		LEG BASE	4	UBRP-SQ01-LEGBASE-12
I		JUMPING MAT	1	UBRP-SQ01-MAT-12
J		COVER PADS	1	UBRP-SQ01-PAD-12-OB UBRP-SQ01-PAD-12-BG
K		SPRINGS	100	UBHWD-SP-7
L		TOP RAIL BOLTS & NUTS	12	UBRP-SQ01-TRBN
M		LEG BASE BOLTS	16	UBRP-SQ01-LBB
N		WASHER	16	UBRP-SQ01-WASHER
O		SPRING PULLING TOOL	1	UBHWD-TH

UBSQ01-16

ITEM	PART IMAGE	MODEL	QTY.	SKU #
A		TOP RAIL A	4	UBRP-SQ01-TRA-16
B		TOP RAIL B	8	UBRP-SQ01-TRB-16
C		CORNER TUBE	4	UBRP-SQ01-CTC1-16
D		T-BAR STYLE 1	4	UBRP-SQ01-DTBAR1
D-1		SILVER T-BAR STYLE 2	4	UBRP-SQ01-D1TBAR3-16
E		T-BAR STYLE 3	8	UBRP-SQ01-ETBAR2
F	F1  F2 	LEG SUPPORT	4 4	UBRP-SQ01-LEGSUP1-16 UBRP-SQ01-LEGSUP2-16
G		LEG EXTENSION	8	UBRP-SQ01-LEGEX-16
H	H1  H2 	LEG BASE	4	UBRP-SQ01-LEGBH1-16 UBRP-SQ01-LEGBH2-16
I		JUMPING MAT	1	UBRP-SQ01-MAT-16
J		COVER PADS	1	UBRP-SQ01-PAD-16-OB UBRP-SQ01-PAD-16-BG
K		SPRINGS	156	UBHWD-SP-8.5
L		TOP RAIL BOLTS & NUTS	16	UBRP-SQ01-TRBN
M		LEG BASE BOLTS	20	UBRP-SQ01-LBB
N		WASHER	20	UBRP-SQ01-WASHER
O		SPRING PULLING TOOL	1	UBHWD-TH

FRAME ASSEMBLY INSTRUCTIONS

FOR UBSQ01-I2

Step 1 - Frame Layout

Layout the trampoline parts on the ground so that you start to form a square with the top rail sections. Make sure to keep all the tubes in the same direction all around the square.

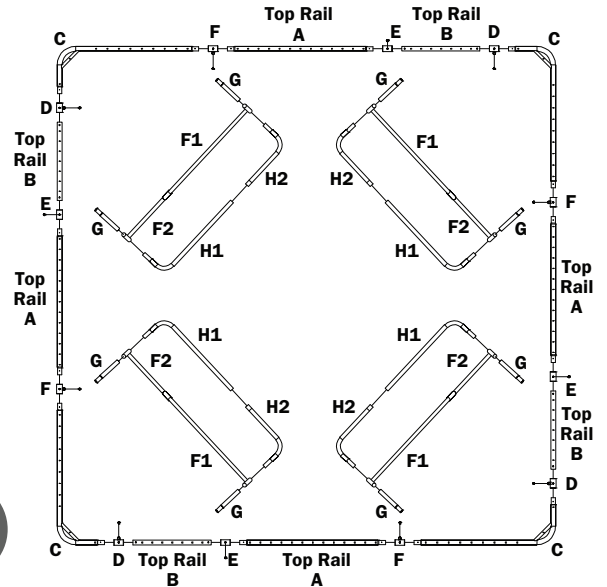

Step 2 - Assemble the Rail with the Legs

1. Assemble each of the Leg Base (H) to the Leg Extension (G)

Attach the leg extensions to the leg base and tightly secure together with the Part M bolts and Part N Washers.

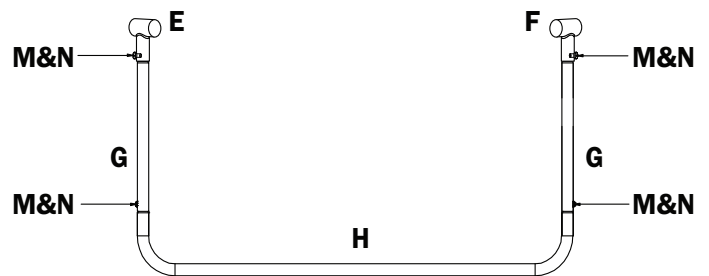
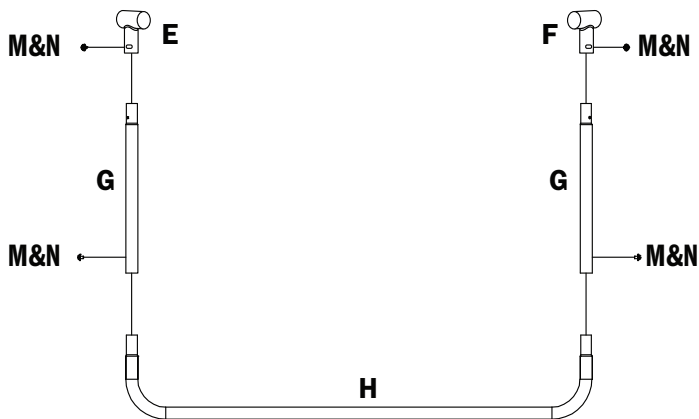

2. Connect the Top Rails to Leg Bases

Attach the leg supports you assembled in step 2. Part 1 to the top rails as shown on the diagram.

NOTE : *Make sure that all screw holes that connect the B rails to the legs are facing the inside of the frame.*

3. Attach all the Corners

Attach the corners to the frame.

4. Secure

Secure the corner pieces with the bolts and nuts to tightly put together the top rail.

5. Secure Legs

Secure the top rails to the leg bases using bolts and washers, securing at each leg.

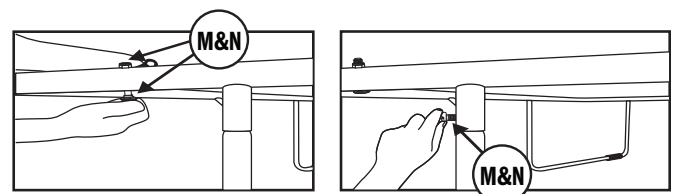

FRAME ASSEMBLY INSTRUCTIONS

FOR UBSQ01-16

Step 1 - Frame Layout

Lay out the trampoline parts on the ground so that you start to form a square with the top rail sections. Make sure to keep all the tubes in the same direction all around the square.

Step 2 - Assemble the Rail with the Legs

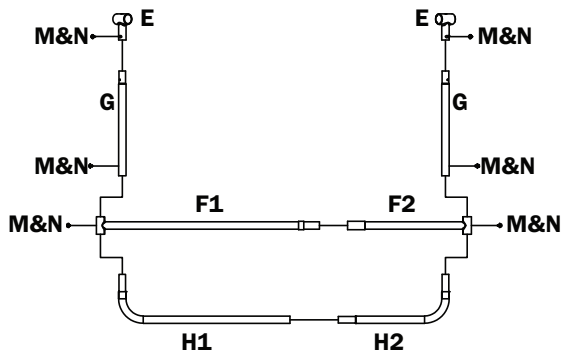
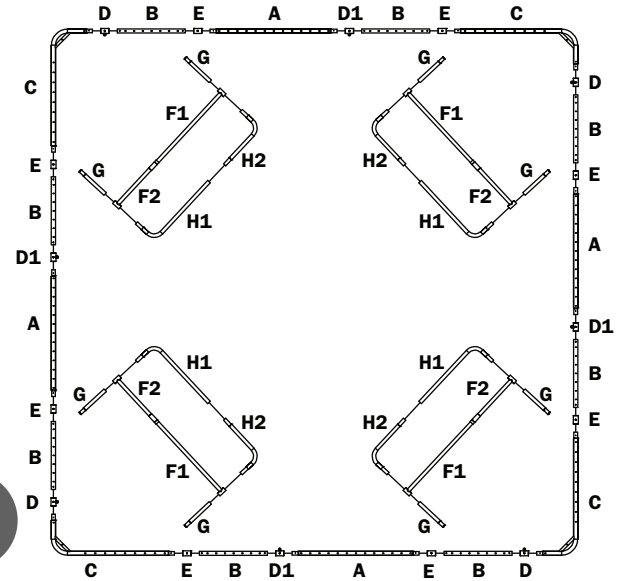

1. Assemble each of the Leg Base (E) to the Leg Extension (D)

Attach the leg extensions to the base and tightly secure together with the Part J bolts and Part K Washers.

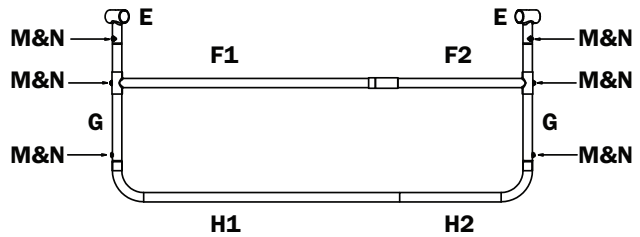

2. Connect the Top Rails Together and Form a square

Connect 1 part to the other in the same layout shown until it forms a complete frame.

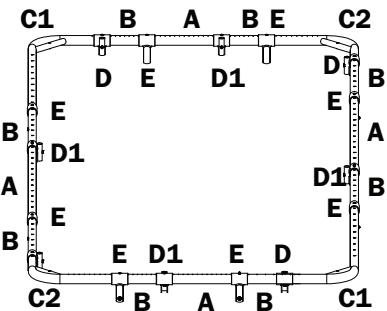

NOTE :

Make sure that all screw holes that connect the A and B parts to the legs are facing the inside of the frame.

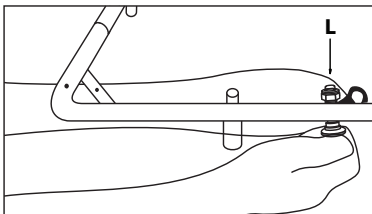

3. Secure

Secure the parts with the bolts and nuts to tightly put together the top rail.

4. Connect the Leg Bases to the Top Rail

Attach the leg supports you assembled in step 1 to the top rails as the image shows, repeat this step to all 4 corners.

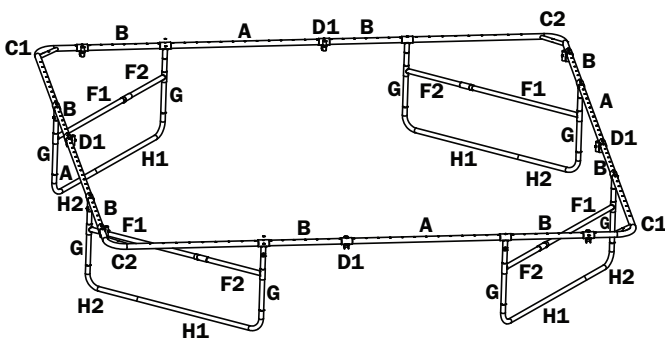

5. Secure Legs

Secure the top rails to the leg bases using bolts and washers, securing at each leg.

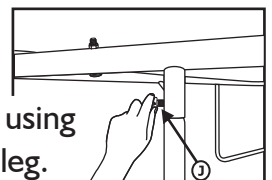

FRAME ASSEMBLY INSTRUCTIONS

Step 3 - Trampoline Mat Assembly



WARNING:

Be careful where you place your hands during spring assembly as connector points can pinch!

1. Lay out the Trampoline Mat inside the frame.
2. Connect all 4 corner springs to the corner top rails.

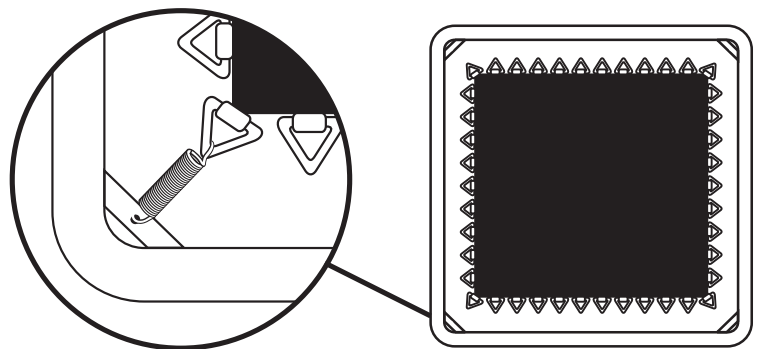
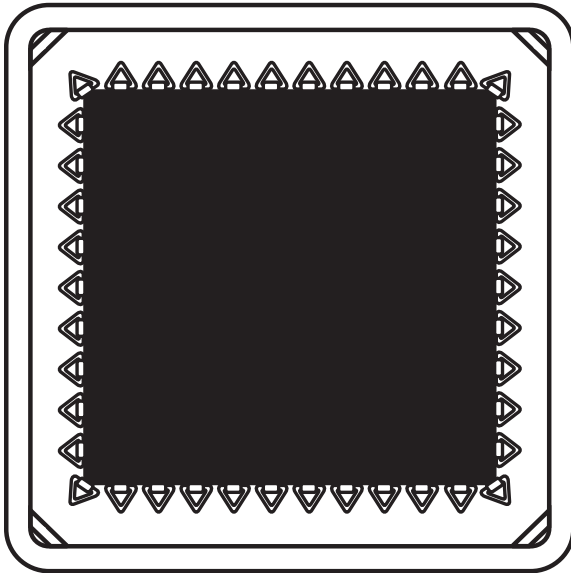

NOTE :

When attaching the springs, attach to mat the end of the spring hooks that is rounder.



1

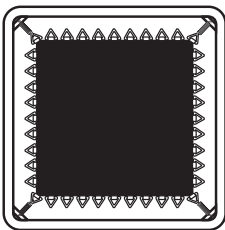

First connect the 4 corner springs

2

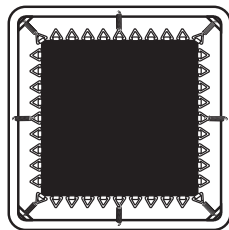

Connect all middle springs

3

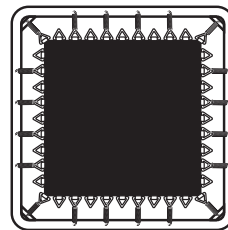

Continue connecting every few springs

4

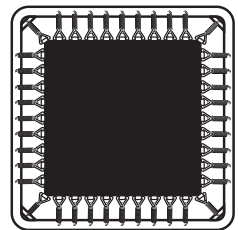

Complete all the rest of the springs

How to use the Spring Pulling Tool

Step I: Hook the more rounded end of the spring onto the Trampoline mat's triangular rings.

Step 2: Extend the spring pull tool and link it up with the other end of the spring. Pull the tool in the direction of the trampoline frame until the spring head is lined up with the hole in the trampoline frame. Slide the spring end into the hole as you remove the tool.

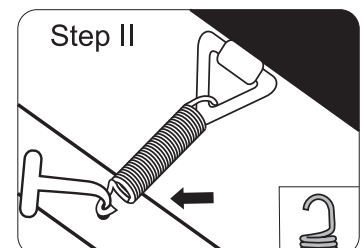
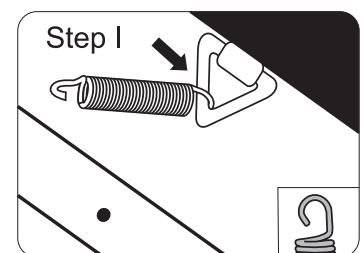

FRAME ASSEMBLY INSTRUCTIONS

Step 4 - Cover Pads Assembly

The trampoline is at a stage close to completion with all the springs in place. Before using the Trampoline please attach the provided safety pads.

STEP 1 :

Lay out 2 sides of the pad shown here and connect with the attached velcro strip.

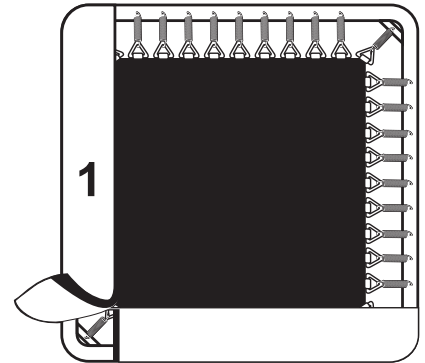

STEP 2 :

Lay out the other 2 pads and connect with velcro.

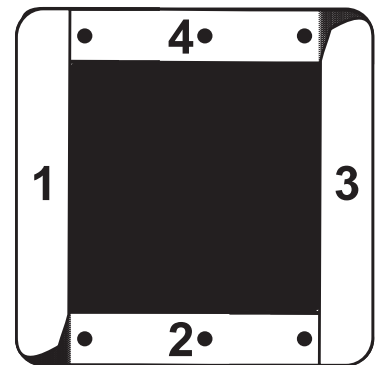





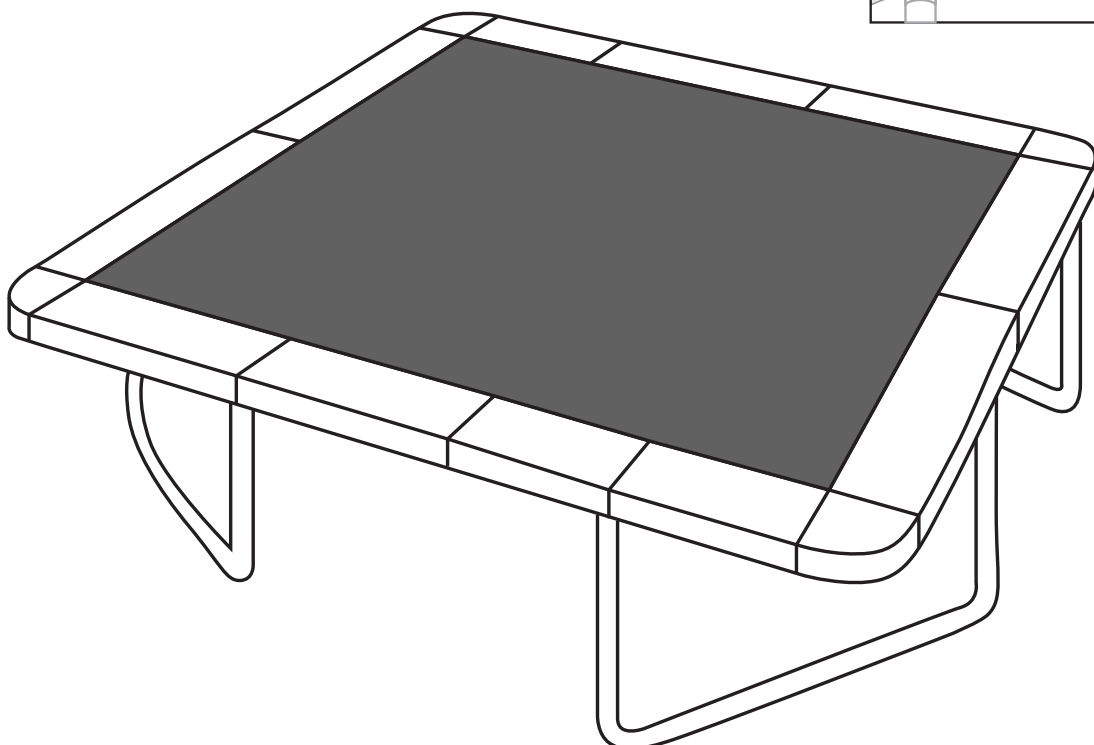
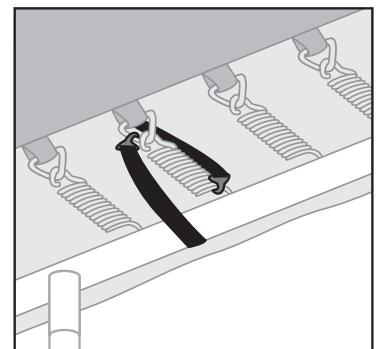



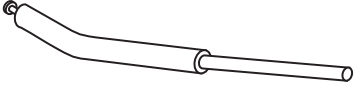

STEP 3 :

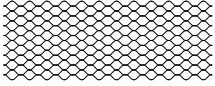
Tie all the cover pad straps onto the top rail of the trampoline. The middle of the pad has a set of straps with two S shaped hooks at the end. Attach one S shaped hook to the springs of the mat, and the other S shaped hook to the V-rings of the mat. Attach the hooks from underneath the mat.

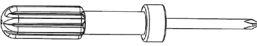
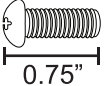

ENCLOSURE PARTS LIST

ITEM	PART IMAGE	MODEL	UBSFQ01-12		UBSFQ01-16	
			QTY.	SKU #	QTY.	SKU #
A		POLE CAP	8	UBRP-SQ01-PC	8	UBRP-SQ01-PC
B		UPPER POLE WITH FOAM	8	UBRP-SQ01-UP	8	UBRP-SQ01-UP
C		LOWER POLE WITH FOAM	8	UBRP-SQ01-LP	8	UBRP-SQ01-LP
D	D1 	FIBERGLASS RODS	8	UBRP-SQ01-FGR-1	4	UBRP-SQ01-FGR-1
	D2 		4	UBRP-SQ01-FGR-2	12	UBRP-SQ01-FGR-2
E		SAFETY ENCLOSURE NET	1	UBRP-SQ01-NET-12-G UBRP-SQ01-NET-12-O	1	UBRP-SQ01-NET-16-G UBRP-SQ01-NET-16-O
F		POLE SCREW	16	UBRP-SQ01-PS	16	UBRP-SQ01-PS
G		POLE SLEEVE COVER	8	UBRP-SQ01-PSC-OB UBRP-SQ01-PSC-BG	8	UBRP-SQ01-PSC-OB UBRP-SQ01-PSC-BG
H		HEX KEY	1	UBRP-SQ01-HEXK	1	UBRP-SQ01-HEXK
I		FIBER GLASS CORNER	4	UBRP-SQ01-FGC	4	UBRP-SQ01-FGC
J		ROPE	1	UBRP-SQ01-ROPE-12	1	UBRP-SQ01-ROPE-16
K		SCREW DRIVER	1	UBRP-SQ01-SD	1	UBRP-SQ01-SD
L		POLE CAP BOLTS	8	UBRP-SQ01-PCB	8	UBRP-SQ01-PCB

SAFETY ENCLOSURE ASSEMBLY

Refer to PARTS LIST for identification of parts.



WARNING:

Two adults in good physical condition are required for the following assembly. For your safety, you should wear proper shoes and clothing. Failure to follow these instructions and warnings may result in injury.

NOTE :

Picture may vary slightly with the different trampoline models.

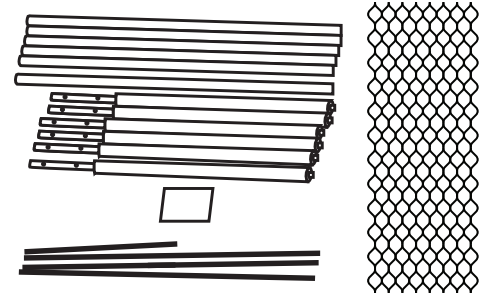

STEP 1 :

Lay out all parts prior to assembly. We recommend that two people carry out the assembly.

STEP 2 :

Both ends of the upper pole have openings for bolts, the end with the bigger hole is meant to connect to the lower pole. Therefore insert the lower pole into the upper pole at the end of the upper pole where the screw opening is bigger. Then place a screw in the hole at the connection. Make sure the EPE foam is covering the poles.

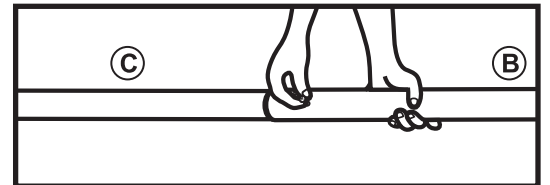
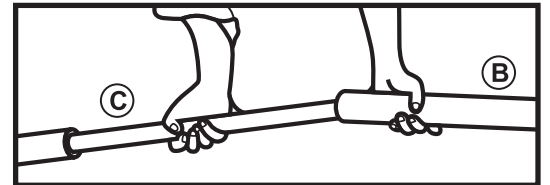

STEP 3 :

Connect the pole cap (A) on the top of upper pole (B). Repeat for each pole.

Refer to the picture to clearly see which way to attach the pole cap, the opening of the pole cap has to be on the same side as the outside bend of the upper pole.

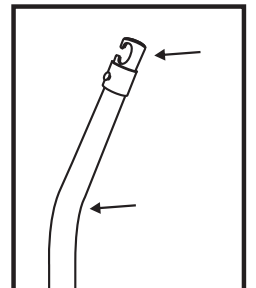
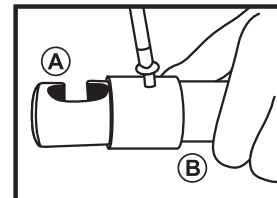

STEP 4 :

Cover all the poles with PVC sleeve (G)

STEP 5 :

Place the assembled poles with the opening of the pole caps facing away from the trampoline, and screw the poles into the trampoline frame with pole bolts.

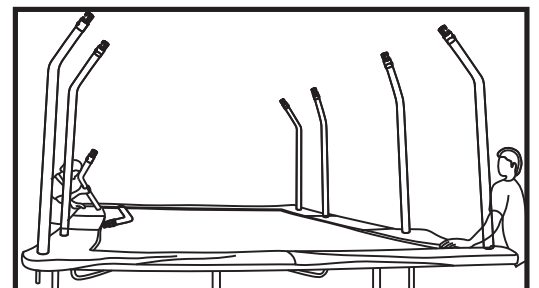

STEP 6 :

Connect the top ring frame using fiberglass parts D1 and D2 with quantities specified on Page 13.

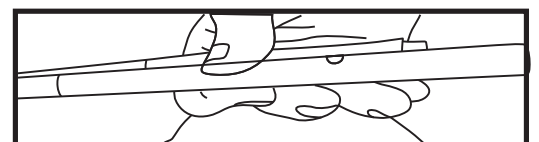

STEP 7 :

Insert the fiber glass into the channel at the top of the safety net.

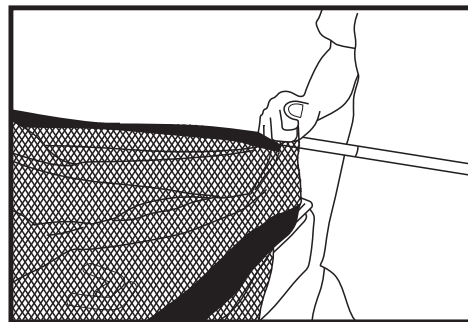

NOTE :

Make sure that the opening of the net (the zipper) is placed in the middle of the wider section of net between poles.

STEP 8 :

Connect the fiber glass to the top of the poles by clicking it into the pole caps. Do this step to all 8 poles.

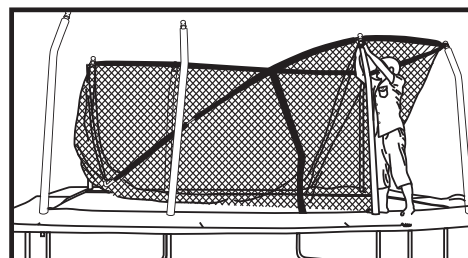

Securing the bottom of the net

1. Connect the net to the V-rings of the trampoline mat using the attached clips, securing at regular intervals. This holds the net in place for you to complete the attachment with rope.
2. Secure one end of the rope by knotting it to the V-ring closest on one side to the trampoline entrance zipper.
3. Weave the rope through the net and every second v-ring successively, moving around the trampoline in the direction away from the entrance zipper.
4. When you complete the weaving and reach the other side of the entrance zipper, secure the other end of the rope also by knotting it to the V-ring closest to the entrance on that side.
5. Secure one end of the rope by knotting it to the V-ring closest on one side to the trampoline entrance zipper.

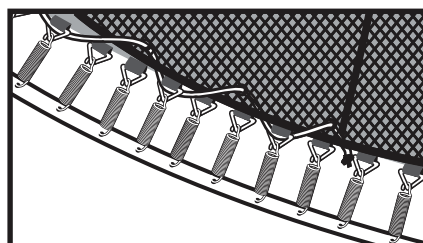
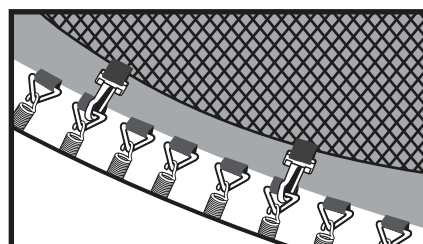

MACHRUS
UPPERBOUNCE®

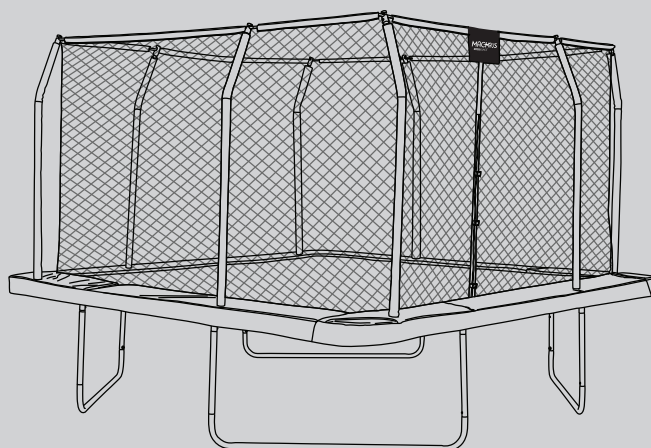

TESTING THE TRAMPOLINE

After assembling the trampoline, it is important that you perform the following safety checks:

Trampoline Safety Checks:

- Using a screw driver, check if all the bolts are tightly secured.
- Look under the trampoline and check all the springs are hooked securely to the frame and triangle rings.
- Move the Trampoline around and check the sturdiness of the frame.
- Using your two hands, put your body weight on one section of the trampoline and release to check that the floor is even.
- Inspect the cover pads and check if they completely cover the springs and frame.
- Make sure the strings of the pads are tied securely.

Enclosure Net Safety Checks:

- Hold onto the safety net and shake it to check that all the enclosure poles are sturdy. Re-tighten any that seem loose.
- Check the safety net for any tears in the stitching or fabric.
- Check the enclosure net zipper and attached to the triangle ring under the trampoline.

Once all the checks are performed and the trampolines has passed all the initial tests (above), then have one person test the trampoline by jumping on the centre continuously for 5 minutes. If the trampoline feels sturdy then your trampoline passes the test.

Congratulations,

you have completed the
trampoline assembly!
Remember to abide by
all the safety rules.

Have fun, play safe...

FUNDAMENTAL BOUNCE TECHNIQUES

The Basic Bounce

- Start from a standing position, feet shoulder width apart with head straight and eyes on the mat.
- Swing your arms forward and up and around in a circular motion.
- Bring feet together while in mid-air and point toes downward.
- Keep feet shoulder width apart when landing on mat.

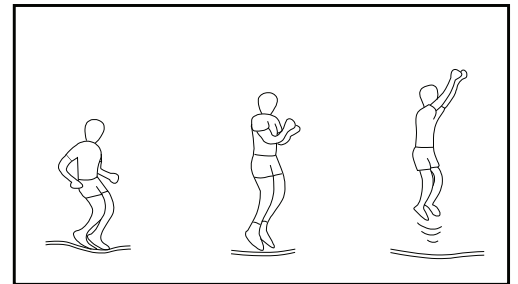

The Breaking Maneuver

- Occasionally the user may lose control of their jump and bounce wildly. Performing the breaking maneuver will allow the user to regain control of the jump and their balance.
- Start with a basic bounce.
- As you land, bend your knees sharply and this will allow you to stop your jump.

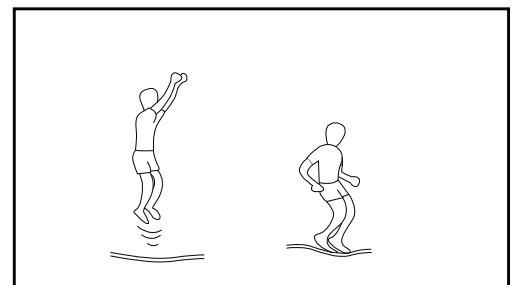

The Hands and knees bounce

- Start with a low controlled basic bounce.
- Land on your hands and knees keeping your back straight.
- Emphasis should be directed at a good four-point landing, and not on jumping height.

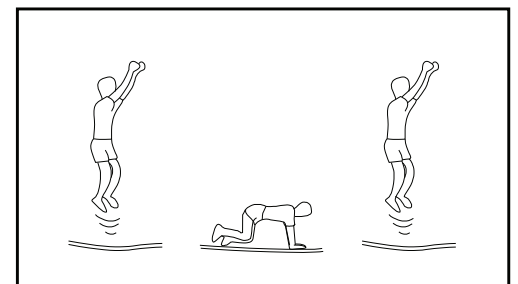

Knee Bounce

- Start with a low controlled basic bounce.
- Land on your knees keeping back straight, body erect and use your arms to maintain balance.
- Bounce back to the basic bounce position by swinging your arms up.

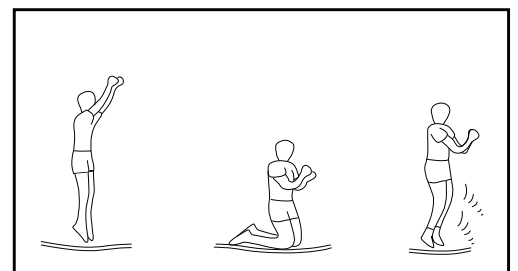

Seat Bounce

- Land in a flat sitting position.
- Place hands on the mat beside your hips.
- Return to erect position by pushing with your hands.

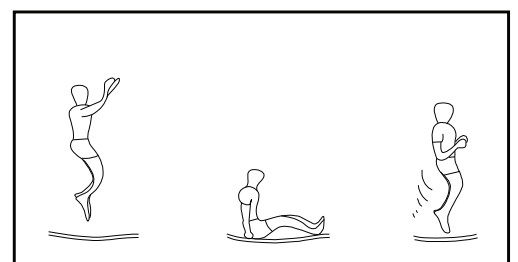

OTHER ACCESSORIES

ITEM	UBSQ01-16
Ladder	UB3S-42-G
Ladder with Flat Steps	UBLBFS3-42
Trampoline Shoe Bag	UBSHB-3
Trampoline Anchor Kit (Set of 4)	UBHWD-AK-4
Deep Fastening Spiraled Anchor Kit - Set of 4	UBHWD-AKB-4
Trampoline Spring Pull Tool (T-Hook)	UBHWD-TH
Upper Bounce Trampoline Jumping Skate	UB-TJB
Springs	UBHWD-SP-7-15
Economy Trampoline Weather Protection Cover, Fits for 9x15 Ft. Rectangular Frames - Black	UBWCRTG-159-BK
44 Inch Trampoline Pole Foam Sleeves, fits for 1.5" Diameter Pole - Set of 12 - Blue	UBFS44-1.5D-S12
44 Inch Trampoline Pole Foam Sleeves, fits for 1.5" Diameter Pole - Set of 16 - Blue	UBFS44-1.5D-S16
44 Inch Trampoline Pole Foam Sleeves, fits for 1.5" Diameter Pole - Set of 12 - Black	UBSF44-1.5D-BK-S12
44 Inch Trampoline Pole Foam Sleeves, fits for 1.5" Diameter Pole - Set of 16 - Black	UBSF44-1.5D-BK-S16
Trampoline pole sleeve protector - set of 4 - blue	UBFPS-4
Trampoline pole sleeve protector - set of 6 - blue	UBFPS-6

Trampoline Replacement Parts



While we provide a large variety of trampolines, we also pride ourselves in the large selection of our trampoline replacement parts which are compatible with most trampolines regardless of their brand.

If you have difficulty finding the correct replacement part for your trampoline,

PLEASE GIVE US A CALL
1-888-965-3331



OR

EMAIL US AT
sales@machrus.com



Our Customer Service Department staff are trained in the details of all trampolines and will help you find the right part to get you bouncing again.