

PLEASE READ ME FIRST!

English

Ui5

USER GUIDE

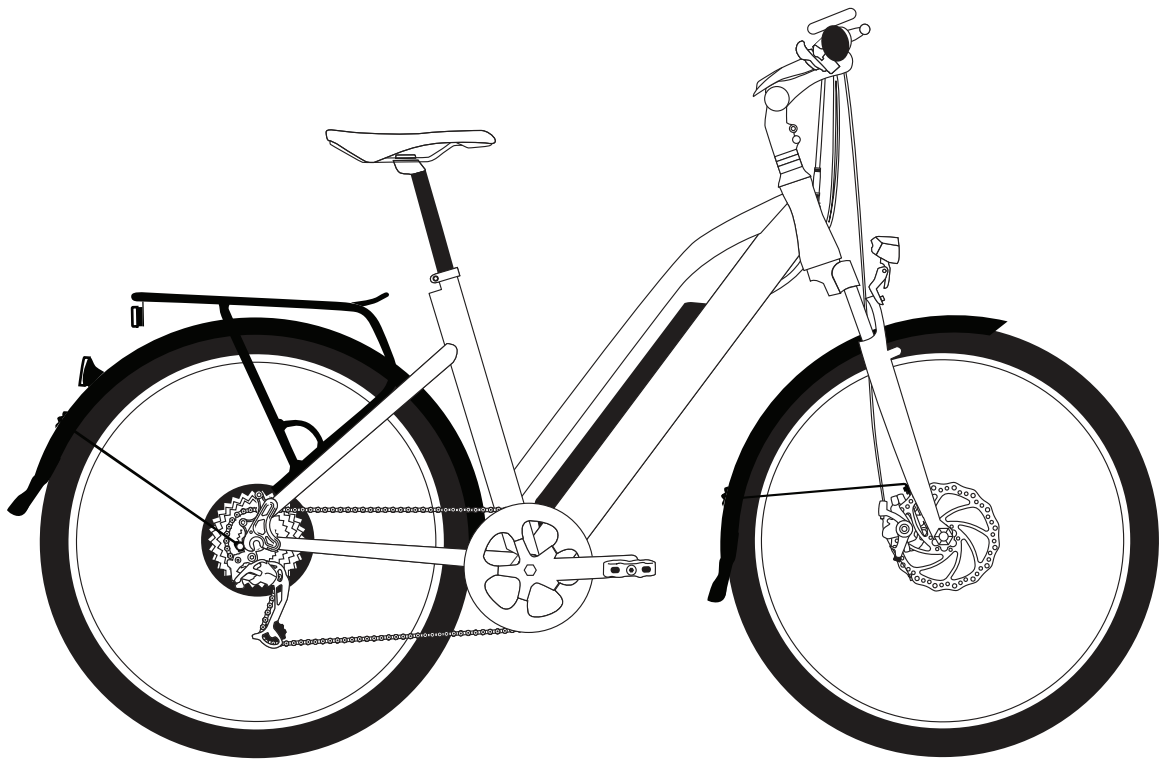

magnum

Table of contents

1. Your E-Bike	2—3
1.1 Introduction	
1.2 General presentation of the vehicle	
2. Function of Display	4—8
2.1 Function summary	
2.2 Full view area	
2.3 Normal view area	
2.4 Normal operation	
3. Using the bike	9—12
3.1 Riding the bike	
3.2 Quick-release devices	
3.3 Adjusting the saddle height	
3.4 Precautions required prior to each use	
3.5 Lubrication	
3.6 Routine maintenance.	
4. The battery	12—14
4.1 Installation and Removal	
4.2 Charging	
4.3 Battery autonomy and lifespan	
4.4 Battery safety instructions	
5. Safety maintenance and recommendations	14—16
5.1 Safety recommendation	
5.2 Maintenance	
6. Accessories	16
7. Warranty	16

Your E-Bike

1.1 Introduction

We would like to thank you for your purchase of a new Magnum e-Bike. The e-bike is equipped with pedals and an auxiliary electric motor. You will thoroughly enjoy riding this new and electrical power- assisted bike with an optional throttle propulsion.

Riding an e-bike means that you're helping preserve the environment, since any CO2 or other polluting gases will not be released. For your safety and for the safety of others, we recommend that you obey all road regulations and wear a protective helmet. For optimal, safe and enjoyable use of the e-bike, make sure you thoroughly read this user guide before you first use it.

Have a pleasant ride!

1.2 General presentation of the vehicle

1.2.1 General information

Weight of bike: 52 Lbs

The dimensions of the bike (MM): L 1750 x W230 x H980 (95% package)

Maximum total weight: 265lbs (includes the bike, battery and rider)



1.2.2 Parts specifications

Spare parts name	Ui5
Motor	Das-Kit, 36V 350W, Rear drive motor
Battery	36V13AH with USB port
Display	Das-Kit LCD, 6 Levels, Error code report
Front fork	SUNTOUR, NEX
E-Brake Lever	ARTEK
Disc Brake	TEKTRO Mechanical Disc Brake
Derailleur	SHIMANO ,Altus, 7 Speed
Tires	SCHWALBE, Big Ben 26*2.15

** Charging time: 5.5 hours 0-100% charge

** Range: 25-55 miles depending on the assistance level and road condition.

** 2 charge indicators: 1 located on the display; 1 located on the side of battery.

Below are the manuals for displays used on the Ui5. The bike will have either the C3 display or L7 display. **The L7 display manual has been inserted after page 8.**

2. Function Display

2.1 FUNCTION SUMMARY

The indicated contents are as below.

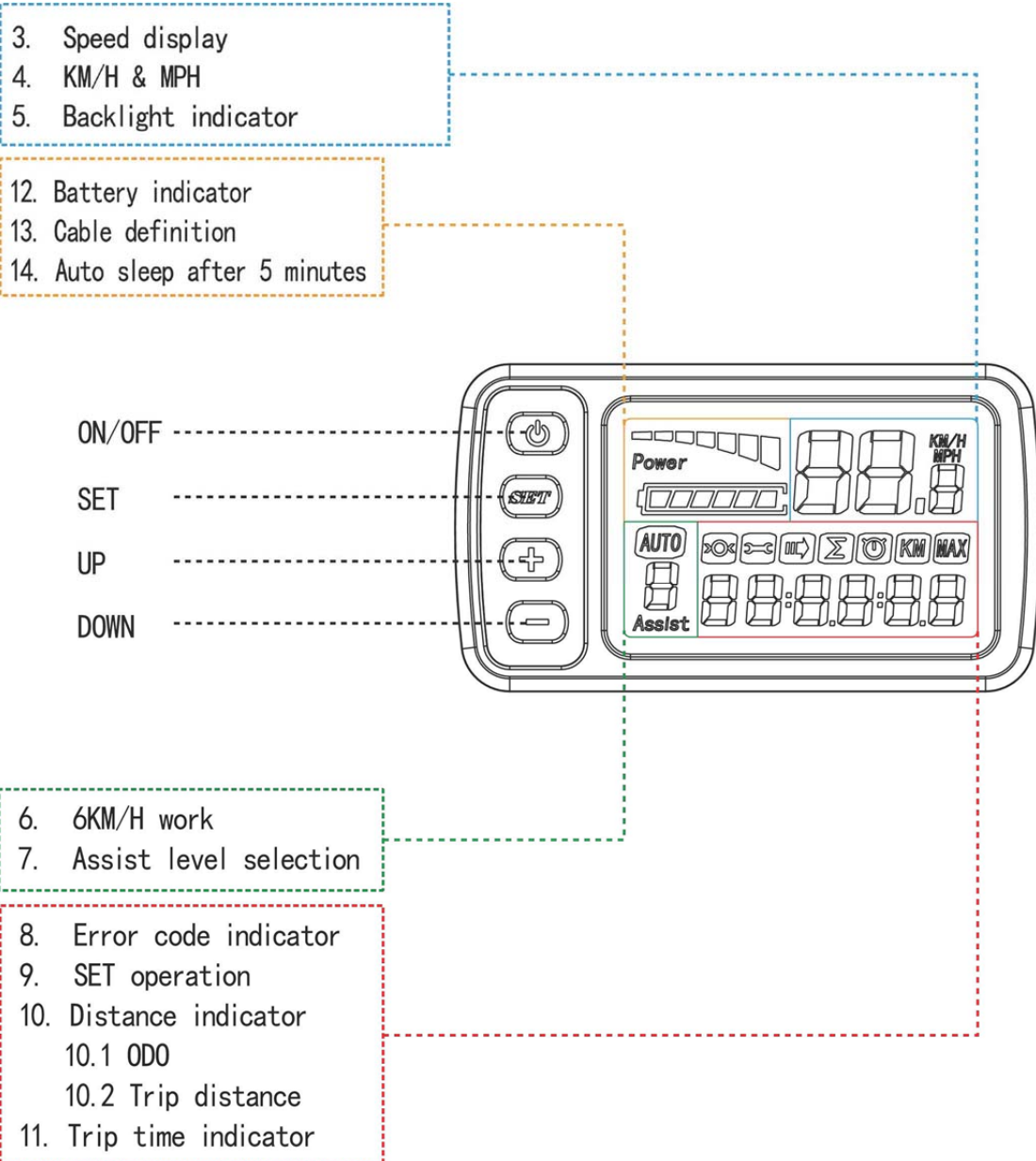

2.2 FULL VIEW AREA

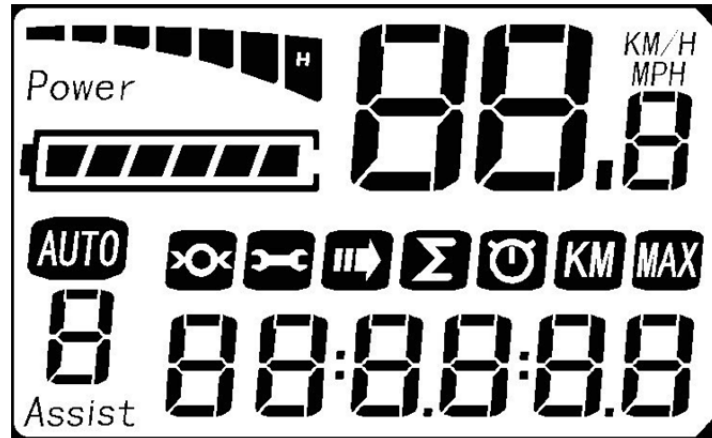

2.3 NORMAL VIEW AREA

The normal viewing area of the C4BT LCD is shown below. Press SET to switch the displaying information. The sequence is: ODO → Riding Time → Riding Distance → Max Speed.

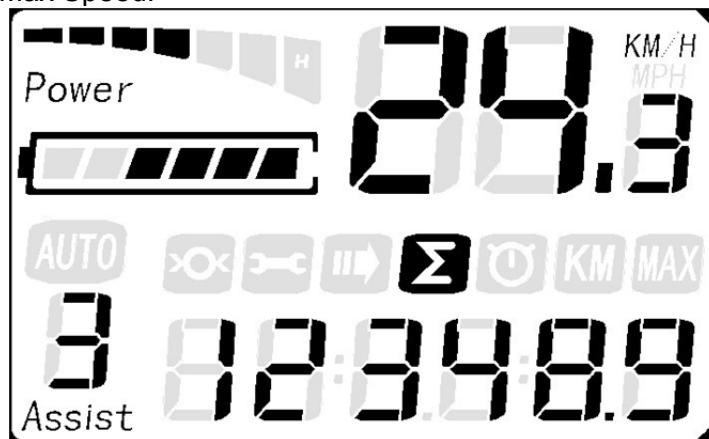

2.4 NORMAL OPERATION

1、ON/OFF

Click ON/OFF and start the display. The display will provide power for the controller. Click ON/OFF again can open the backlight. With display on, press ON/OFF for 3 seconds to turn off the power. With the display off, there is no battery consumption. The leakage current is no more than 2 μ A.

※ The display will go to sleep when speed is 0 km/h for 5 minutes.

2、CURRENT DISPLAY

The current indicator below represents the working discharging current of the controller, each segment represents a working current of 2A, six segments means ≥ 12 A.



3、 SPEED DISPLAY

The current riding speed of the e-bike displays as below.



4、 KM/H & MPH

Select KM/H or MPH for the speed and mileage. The display will show the denomination in the selected units.

5、 BACKLIGHT

With the power on, click the ON/OFF to turn on the backlight. Click it again to turn off the backlight.

6、 6 KM/H WORK

Hold UP for 2 seconds and enter into the mode of power assist walk. The e-bike is traveling at 6Km/h.

7、 ASSIST LEVEL SELECTION

Click UP or DOWN to change the stages and output power ratio, the output power cycle from level 0 to level 6 for the default (the levels can be customized by user) , the default value is level 3.

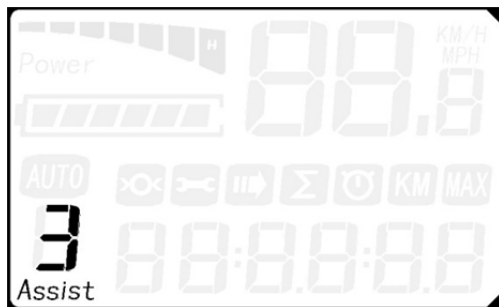

8、 SET OPEARATION

8.1 Reset ODO

Hold UP and DOWN for 12 seconds to clear the ODO.



8.2 Reset trip distance and max speed

Hold SET for 3 seconds, SET 1 hold DOWN for 2 seconds to clear trip distance, trip time and max speed.



trip distance



trip time



max speed

8.3 Wheel diameter setting

Press SET for 3 seconds, SET 2 to enter into wheel diameter setting. Select the accurate wheel diameter value to ensure the accuracy of display about speed and mileage.

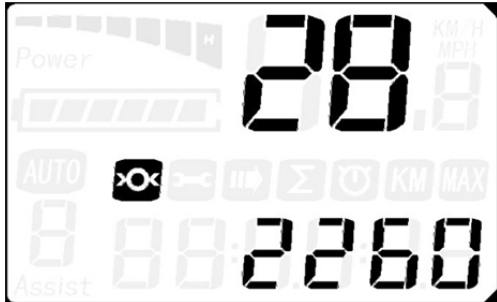

※Click UP or DOWN to set the wheel diameter.

8.4 Throttle speed setting

Press SET for 15 seconds to enter into the throttle speed setting interface. Click UP or DOWN to set the throttle speed limited or not, the limited throttle speed is 20MPH.

8.5 KM/H & MPH

Press SET for 3 seconds, SET 3 to switch from KM/H and MPH.

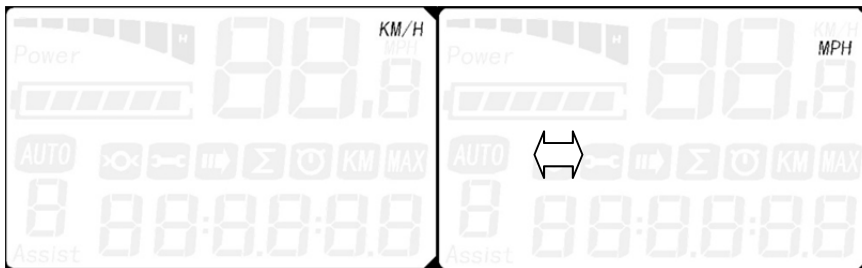

9、 DISTANCE INDICATOR

With the display on, press SET to switch the display information. In turn shows ODO and trip distance.

9.1 ODO

The ODO records the driving mileage from using.

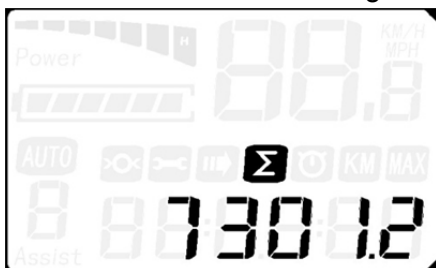

9.2 Trip distance

Trip distance records the driving mileage, it is displayed as below.

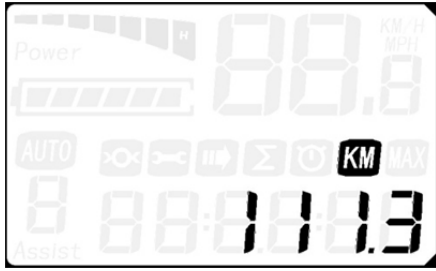

10、 TRIP TIME INDICATOR

The trip time records the riding time, displayed as below.



11、 ERROR DISPLAY

Press SET and DOWN in the case of not working to see all the error codes. The error codes are defined as follows:

- | | |
|------------------------------------|----------------------------|
| [0] Fault-Free | [1] Current Abnormality |
| [2] Throttle Abnormality | [3] Motor's Phrase-Lacking |
| [4] Hall Abnormality | [5] Braking Abnormality |
| [6] Undervoltage | [7] Motor Stalling |
| [8] Controller Receive Abnormality | |
| [9] Display Receive Abnormality | |

12、 BATTERY INDICATOR

When the battery capacity is full, the six battery segments are all light. When the battery is low, the battery frame will flash. It indicates that the battery is severely low and needs to be recharged immediately.



Low battery flash

Instruction Manual for L7

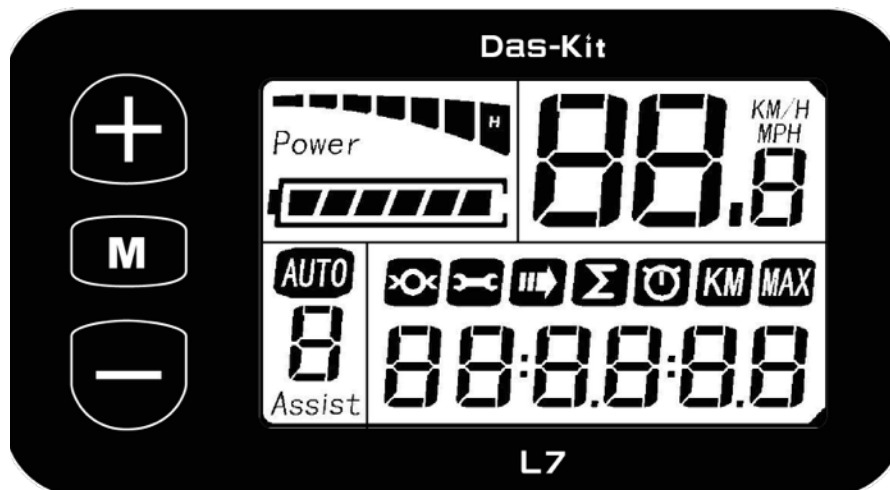

1. Instruction manual

Dear customer, please read the instruction manual carefully before operating your e-bike better. We'll show you every part of display instruction in the most concise language, including the installing, setting and normal use. At the same time, we'll help you solve problems.

2. Appearance and measurement

2.1 Main material and colour

The display adopts black ABS material and the support is made of nylon. The material of the shell can use normally among the temperature -20°C to 60°C and guarantee good mechanical capacity.

Dimension figure (unit: mm)

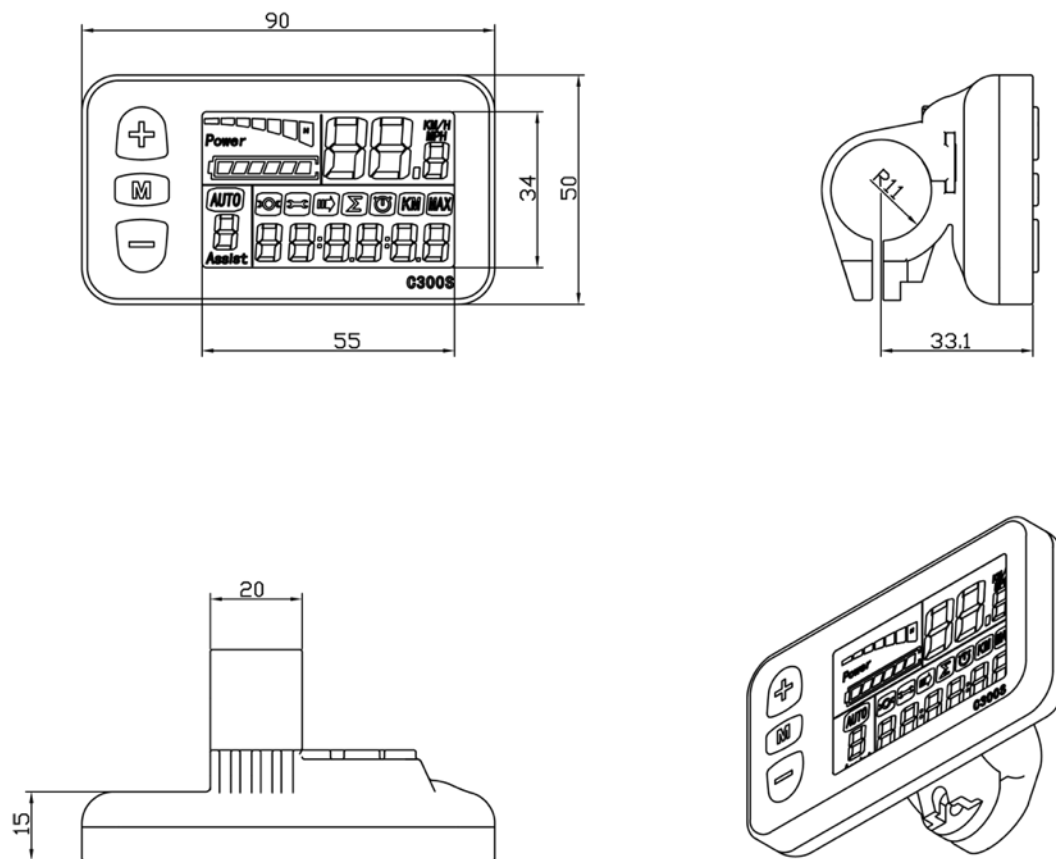

3. The button

There are three buttons on the display, including “M”, “+” and “-”.

“M” presents MODE/ON/OFF.

“+” presents UP. “-” presents DOWN.

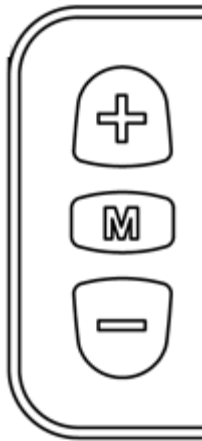

4. Function Display

4.1 FUNCTION SUMMARY

The indicated contents are as below.

1. Switch

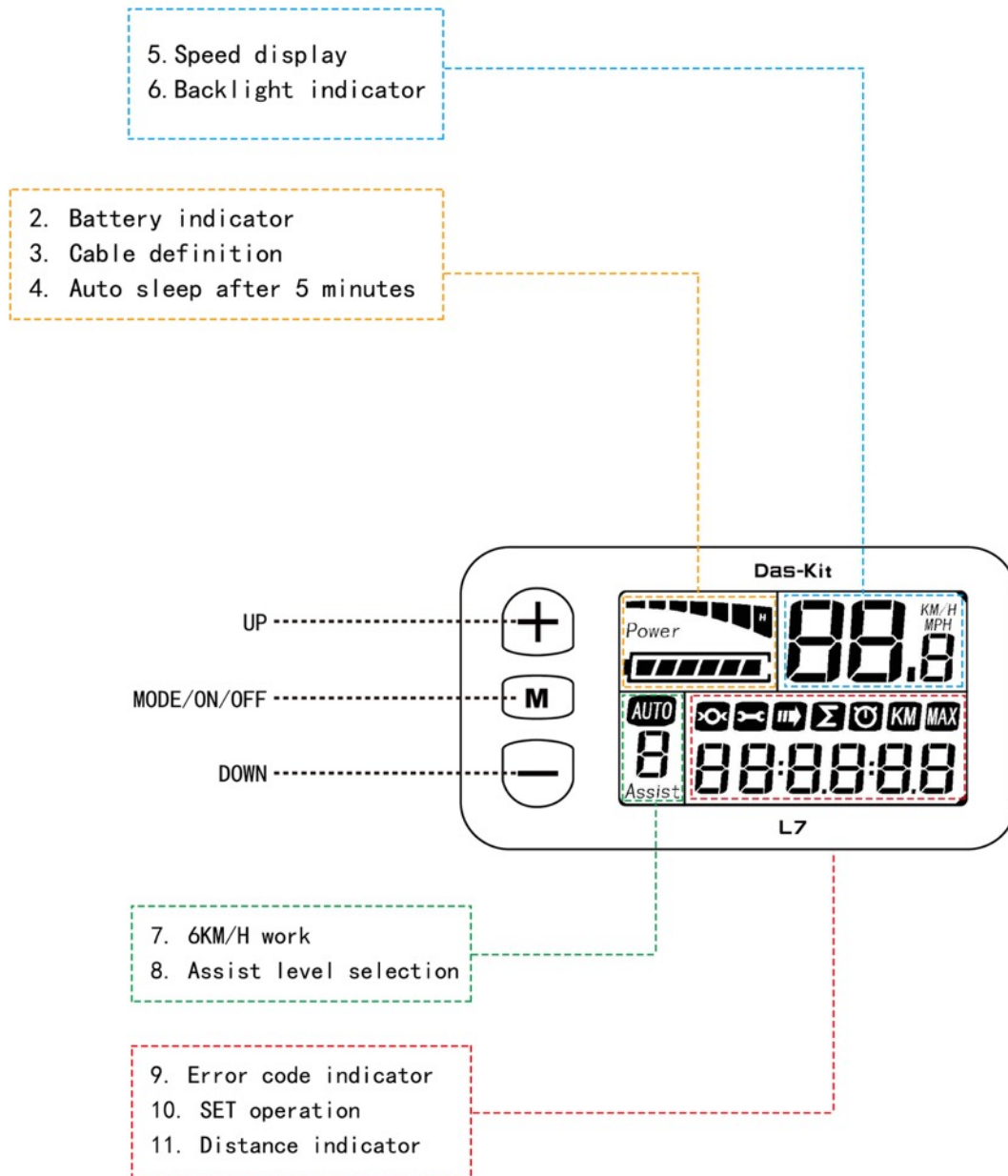

4.2 FULL VIEW AREA

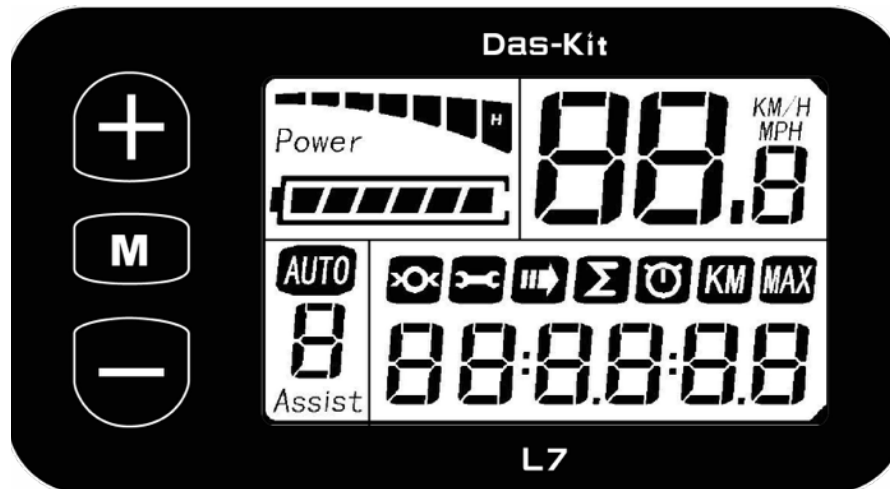

4.3 NORMAL VIEW AREA

The normal view area of the L7 is shown below.

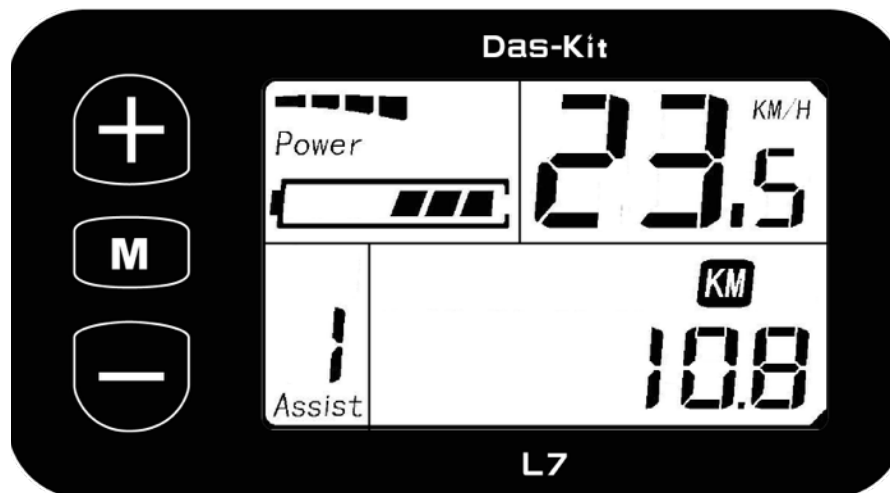

5. Normal operation

5.1 ON/OFF

Press M then the display is activated. With display on, press M for 2 seconds to turn off power. With the display off, there is no battery power consumption. The leakage current is no more than 2μA.

※The panel will automatically power-off when speed is 0 km/h for 5 minutes.

5.2 CURRENT DISPLAY

It represents the discharging current of the controller currently, each segment is 2A, six segments are $\geq 12A$.



5.3 SPEED DISPLAY

It displays the current riding speed of e-bike. The speed display is as below.



5.4 BACKLIGHT INDICATOR

With the power on, press "+" for 1 second can turn on the backlight. Press it for 1 second again can turn off the backlight.

5.5 6 KM/H WORK

Hold "-" for 2 seconds and enter into the mode of power assist walk. When the icon is lighting, the e-bike is traveling at 6km/h. Assist walk will be removed automatically after hand away. The assist walk display is as below.

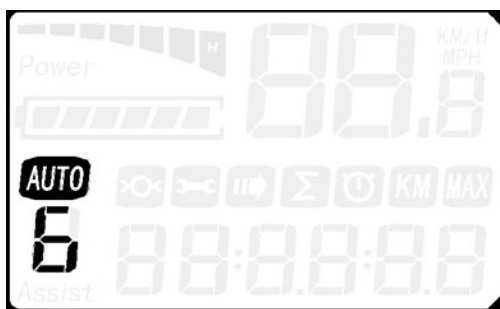

5.6 ASSIST LEVEL SELECTION

Click UP or DOWN to change the stages and output power ratio, the output power cycle from level 0 to level 6 for the default (the levels can be customized by user) , the default value is level 1.

magnum

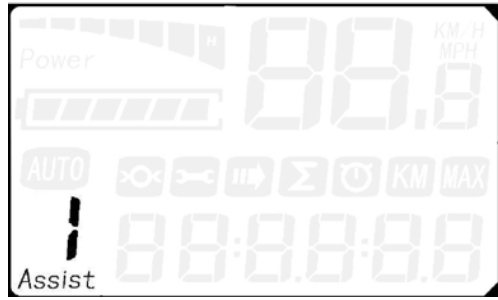

5.8 DISTANCE INDICATOR

With the display on, press M to switch the display information. In turn shows ODO, trip distance, riding time and max speed.



trip distance



riding time



max speed

5.8.1 ODO

The ODO records the driving mileage from using.



5.8.2 Trip distance

Trip distance records the driving mileage. it displays as below.

Hold “+” for 5 seconds, the trip distance will be reset and skip to the trip distance interface.



5.8.3 Trip time indicator

The trip time records the riding time, it displays as below.



5.8.4 Max speed

The max speed records the riding speed, it displays as below.

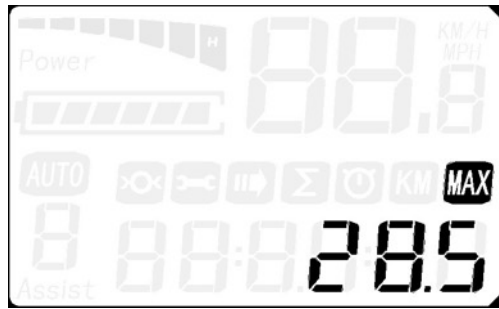

※Click  to start in turn show automatically.

5.11 BATTERY INDICATOR

When the battery capacity is high, the six battery segments are all light. When the battery is low, the battery frame will flash. It indicates that the battery is severely low and needs to be recharged immediately.

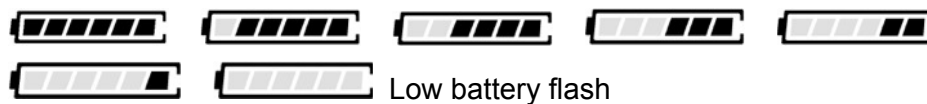

3. Using the bike

3.1 Riding the bike

Before taking off, make sure that you activate the battery by pressing on the button located on the side of battery.

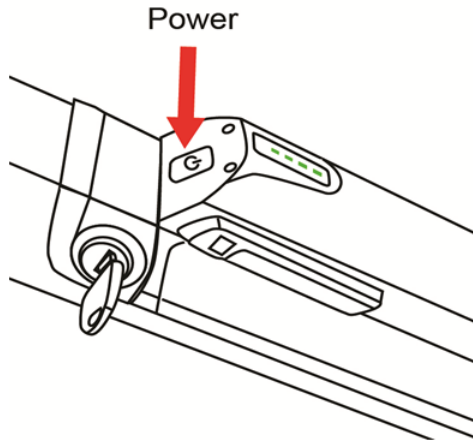

The 4 LEDs located on the top of the battery indicate the charge level.

Turn on the display unit on the handlebar. Select your desired assistance level and begin pedaling. You'll find the motor start working as soon as you start pedaling. When the bike is turned on it will automatically start in pedal assist level 1. Some riders may prefer to turn the bike on and level down to 0 pedal assist so they can get on the bike and begin pedaling before adding pedal assist.

When you use the brakes, the contactor located within these brakes will halt the motor's assistance immediately.

The left brake lever controls the front brake. The right brake lever controls the rear brake.

You can also use the bike without electric assistance by turning off the battery (switch off the battery by adjusting the assistance level on 0). The motor will then feature zero resistance: you'll be freewheeling. Select the appropriate gear by activating the 7-speed gear lever.

3.2 Quick-release devices

Tighten the adjusting nut by hand and move the quick release lever to the closed position. You should feel considerable resistance while closing the lever. If not, re-open and re-tighten the nut, then move the lever to the closed position so it is in line with the frame.

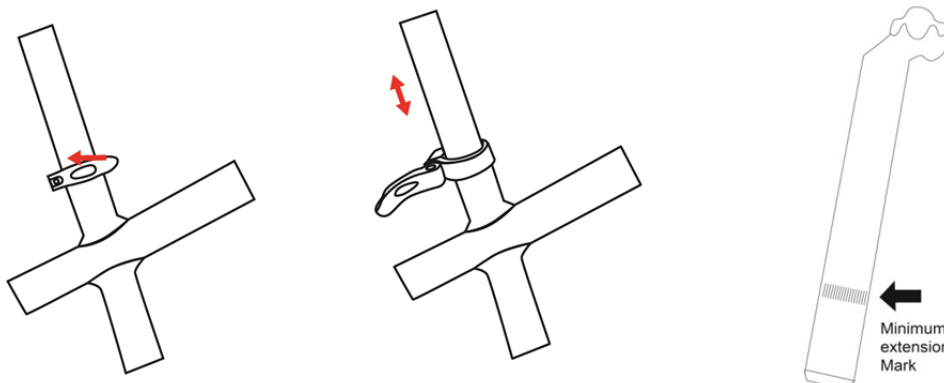

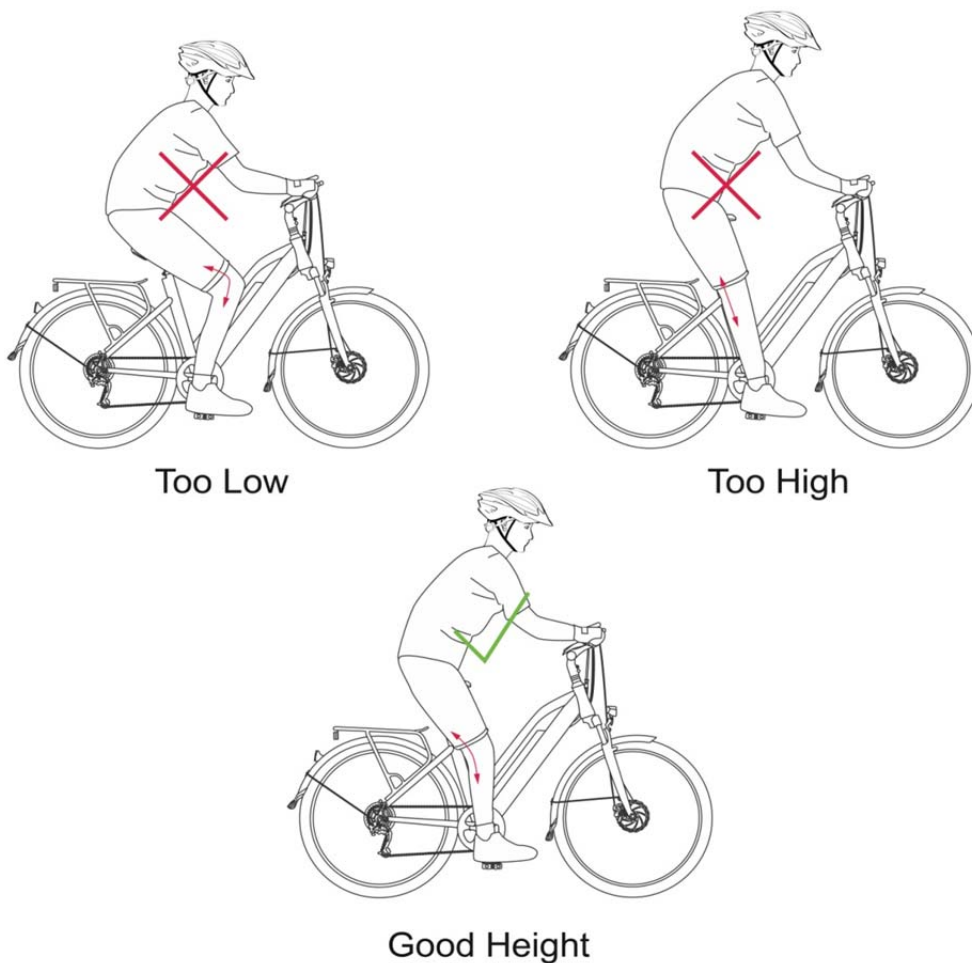

3.3 Adjusting the Saddle Height to Suit the Rider

3.4 Precautions required prior to each use

Verify that the brakes and the front & rear lights are all working properly. Also, check the pressure of the tires.

On derailleur geared bicycles the rear derailleur automatically tensions the chain.

Make sure that all hinges and levers on your bike are properly locked. Indeed, when using the bike on a regular basis, the tension of the hinges' adjustment and locking systems can change slightly. Whenever necessary, adjust the tension once again.

This bike is not designed for rough usage condition, such as jumps, riding up or off of pavements, and riding on unpaved roads. For your own safety, do not modify the bike.

Please note: if you use the bike frequently, it is recommended that you inspect the state of the fork, the frame, the suspension and the fasteners. The materials and components are subject to usage and wear and tear.

If you have any doubts about the condition and safety of your e-bike, contact your dealer, who will proceed with the necessary inspection.

3.5 Lubrication

Frequency	Component	Lubricant	How to Lubricate
Weekly	Chain Derailleur Pulleys Derailleurs Brake Calipers Brake Levers	Chain Lube or Light Oil Chain Lube or Light Oil Oil Oil Oil	Brush On or Squirt Brush On or Squirt Oil Can 3 drops from oil can 2 drops from oil can
Monthly	Shift Levers	Lithium Based Grease	Disassemble
Every Six Months	Freewheel Brake Cables	Oil Lithium Based Grease	2 squirts from oil can Disassemble
Yearly	Bottom Bracket Pedals Derailleur Cables Wheel Bearings Headset Seat Post	Lithium Based Grease Lithium Based Grease Lithium Based Grease Lithium Based Grease Lithium Based Grease Lithium Based Grease	Disassemble Disassemble Disassemble Disassemble Disassemble Disassemble

Note: The frequency of maintenance should increase when using in wet or dusty conditions. Do not over lubricate - remove excess lubricant to prevent dirt build up. Never use a degreaser to lubricate your chain.

3.6 Routine maintenance

3.6.1. Recommended Torque Values.

Front Wheel Nuts	22-27 Newton Meters	16.2- 19.8 ft.-lb.
Rear Wheel Nuts	24-29 Newton Meters	17.5- 21.3 ft.-lb.
Seat Binder Nut	12- 17 Newton Meters	8.8- 12.5 ft.-lb.
Seat Pillar Clamp Nut	15- 19 Newton Meters	11.0-14.0 ft.-lb.
Brake Anchor Nut	7- 11 Newton Meters	5.1- 8.1 ft.-lb.
Handlebar Clamp Nut	17- 19 Newton Meters	12.5- 14.0 ft.-lb.
Head Stem Expander Nut	17-19 Newton Meters	12.5- 14.0 ft.-lb.
Crank Cotter Pin Nuts	9-14 Newton Meters	6.6- 10.3 ft.-lb.
Brake Centre Bolt	2-17 Newton Meters	1.5- 12.5 ft.-lb.

3.6.2. Service checklist

Frequency	Task
Before every ride	Be sure batteries are fully charged Check tire pressure Check brake operation Check wheels for loose spokes
After every ride	Be sure to fully charge batteries Quick wipe down with damp cloth
Weekly	Lubrication as per schedule 3.7
Monthly	Inspect wires Inspect connectors Check derailleur adjustment Check brake adjustment Check brake and gear cable adjustment Check tire wear and pressure Check wheels are true and spokes tight Check hub, head set and crank bearings for looseness Check pedals are tight Check handlebars and stem are tight Check seat and seat post are tight and comfortably adjusted Check frame and fork for trueness Lubrication as per schedule 3.7 Perform safety check
Every six months	Lubrication as per schedule 3.7 Check all points as per monthly service Check and replace brake pads, if required Check chain for excess play or wear
Yearly	Lubrication as per schedule 3.7

4. The battery

4.1 Installing and removing the battery

To remove the battery, unfasten the lock which is located on the battery box. Remove the battery by pulling it out.

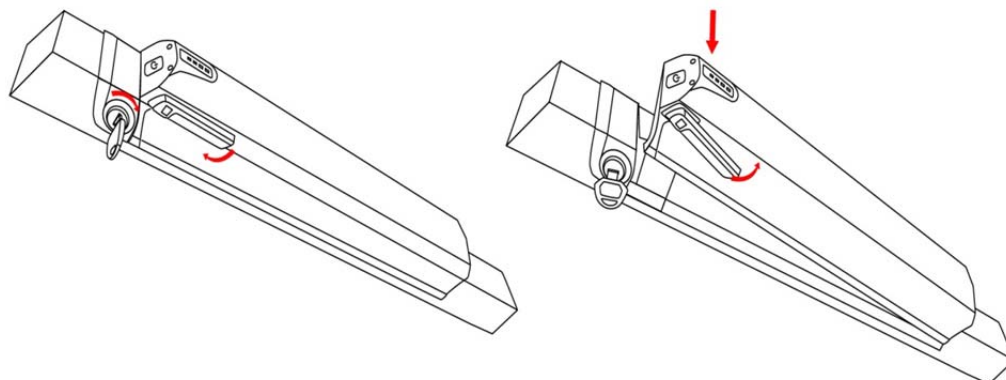

To put the battery back into place, insert the battery along to the guide rail. Push it closely against the controller box. Click in place to fasten the battery lock.

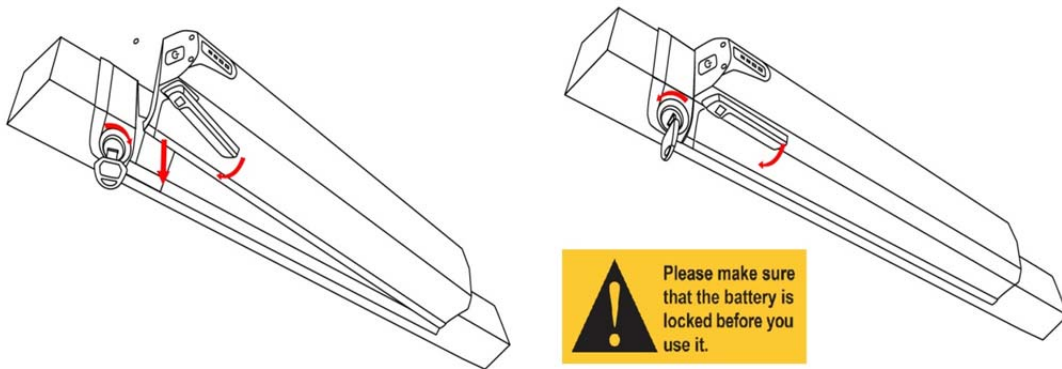

4.2 Charging the battery

Never let a battery be charged unattended.

The battery's voltage is indicated by the 4 LED lights located on the side of the battery, and also on the display unit located on the handlebar.

Your battery must be charged in an ambient temperature, on a non-flammable and dry surface, away from any sources of heat, humidity or flammable materials and should never be covered.

Here are the steps to be followed when charging your battery:

Step 1	Turn off the battery. The LED lights will be off.
Step 2	Plug the charger into the socket and then insert the charger's plug into the battery while battery is switched off.

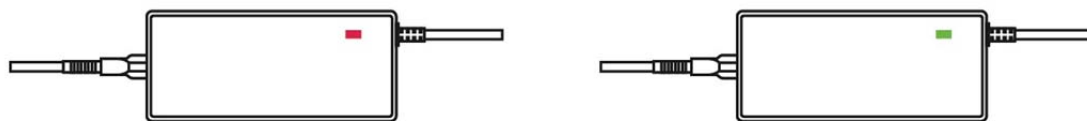

Step 3	the charger's LED indicators light up in the following manner: <ul style="list-style-type: none"> •The red LED light on indicates the battery is being charged. (A) •The red LED light turns green indicating the battery is fully charged; you can then unplug the charger. (B)
---------------	--

(A)

(B)

When depleted, it takes 5.5 hours for the battery to completely recharge using the standard charger supplied with the bike.

4.3 Battery Range and Lifespan

4.3.1 Range

The bike's range is from 25-55 miles, depending on various factors (degree of assistance used, topology, rider's weight, frequent stops/start-ups, hills, tire pressure, etc...) To increase the battery efficiency always begin riding while pedaling (using the throttle to start riding can decrease the riding range and eventually the battery life)

4.3.2 Battery

Your bicycles battery is just like any household battery. It contains a limited amount of cycle-life, which diminishes as it is being depleted throughout its life. When the available autonomy no longer meets with your needs, you will need to replace the battery.

4.3.3 Maintenance

If you don't use your bike for a period of time exceeding 2 months, store it in a humidity-free area to protect the electronic components and make sure that the battery is not completely discharged.

Note: *Never store a completely discharged battery as it might result in permanent damage. During the winter or long storage periods, it is recommended that you charge the battery halfway every 2 months. Don't forget to switch it off. Store your battery at a temperature between 15° and 25°.*

4.4 Battery Safety Instructions

Your bike's battery is an electric component made up of chemical elements. For your safety, it is imperative that you obey the following rules:

Always handle with great care
 Always keep away from children
 Do not disassemble, hit, pierce or submerge it
 Keep it away from temperatures exceeding 60°C
 Never create a connection between the contacts located at the bottom of the battery
 Never let the battery charge unattended
 Never sleep near a battery that is charging
 Only use the charger that came with your bike or supplied by your dealer
 If your battery is damaged, do not use it



Battery FAQs

How do I best preserve my Magnum Bikes battery life?

- Always pedal along with your E-bike. While riding up hills especially you should be assisting your E-bike so the battery isn't depleted too quickly.
- Always keep your battery charged. Lithium batteries life cycle can be extended by not depleting your battery fully. Even if you haven't depleted your battery entirely during your ride we suggest that you charge it.
- Do not overcharge your battery. Be sure not to leave your battery charging for more than 24 hours at a time.

How do I extend the range of my Magnum Bikes E-bicycle per charge?

- Your E-bike will consume much less battery when you begin riding by pedaling and not using the throttle. Stop and go riding with the throttle can limit the range of your E-bike.
- Always make sure your tires are inflated properly. Riding on low pressure tires will consume more energy.
- Always pedal up hills. Do not use throttle only when riding up hills.
- Use your mechanical gears correctly. When you are pedaling make sure to be in the correct gear. Lower your gears while going up hills and raise the gears on flat and downhill terrain..

5. Safety and maintenance Recommendations

5.1 Safety recommendations

Helmet

For safe riding, always wear a bicycle helmet.

Tires

Inspect the wear of your tires on a regular basis and verify the tire pressure at least once a month. Tire pressure: 40-65 PSI depending on the weight of the user.

Wheel-rims

Take care of any risk of damage in case of defective wheel-rims. Swap them immediately when the rim is worn out.

Important: braking distance increases on humid or slippery ground

Gears

Like the chain, the freewheel must be kept clean and well lubricated. If the chain has become worn and needs to be replaced, it is likely that the freewheel will also have become worn and should be replaced as well. Take the chain off the freewheel and rotate it with your hand. If you hear a grinding noise or the freewheel stops suddenly after spinning, it may need to be adjusted or replaced.

Battery

Cf. Chapter. 4

WARNING: As with all mechanical components, the bicycle is subjected to wear and tear caused by usage over time. Different materials and components may react to wear or stress fatigue in different ways. If a component is worn, it may suddenly fail possibly causing injuries to the rider. Any form of crack, scratches or change of color in highly stressed areas indicate that the component should be replaced.

5.2 Maintenance

Caution:

Bike maintenance and repair require specific skills and appropriate tools. Do not repair your bike or change any of its settings if you have the slightest doubt regarding your ability to correctly proceed with such work. Any adjustments or repairs that are not properly done can damage the bike and lead to accidents resulting in extensive injury. Use only genuine replacement parts for safety-critical components and contact your dealer when necessary.

Cleaning

Always remove the battery when cleaning. Use soapy water or water mixed with a gentle detergent, and then rinse it with clean water. Make sure that the controller located behind the battery compartment is not exposed to humidity as it contains electronic components. Do not use a high pressure washer!

Maintenance

Make sure your bike is safe for the environment. Used parts must be disposed of in appropriate selective sorting recycling bins. A battery which no longer works must be returned to your dealer so that he may pass it to a recycling company.

Replacing the rear light batteries: remove the screw to access the batteries.

(It is recommended that you replace them every year)

Engine: the motor does not require any sort of maintenance.

Chain: It is recommended that you lubricate your bike's 7 speed gearwheels and chain on a regular basis using appropriate products (ask your dealer for advice).

6. Accessories

Mudguards (Place the mudguard assembly between the stays, make sure the mudguard bracket holes line up with those in the frame. Tighten all bolts and screws until snug.)

Helmet, baskets and storage pouch are not provided with the vehicle.

To order these accessories, get in touch with your dealer.

Use only genuine replacement parts for safety-critical components.

7. Warranty

You are provided with a warranty for one year from the day you purchase your Magnum Bike. Details regarding your bike's warranty coverage terms are available from your dealer and on our website: www.magnumbikes.com/warranty

Have a safe and pleasant ride,

Thank you for choosing Magnum Bikes!

CE

magnum