

# **AIR FRYER OVEN**

NB-AF002

## **User Manual**

**Questions or Concerns?**

[appliancehelp@tyutech.com](mailto:appliancehelp@tyutech.com)



# CONTENTS

## KNOWING YOUR AIR FRYER OVEN

## USING YOUR AIR FRYER OVEN

## CLEANING AND MAINTENANCE

## TROUBLESHOOTING

# “WARNING

## BEFORE USING THIS APPLIANCE READ ALL INSTRUCTIONS AND CAUTIONARY MARKINGS IN YOUR USER MANUAL AND ON THE APPLIANCE”

This appliance is not intended for use by persons (including children) with reduced physical, sensory or mental capabilities, or lack of experience and knowledge, unless they have been given supervision or instruction concerning the use of the appliance by person responsible for their safety.

- Close supervision is necessary when any appliance is used by or near children. Children should be supervised to ensure that they do not play with the appliance. Cleaning and user maintenance shall not be done by children unless they are older than 8 and supervised.
- Use the appliance only for intended household purposes as described in this User Manual. Any other use is not recommended that may cause fire, electric shock, or injury to persons.

**DO NOT** place the appliance against a wall or other appliances. Leave at least 4 inches of free space on the back and sides and 4 inches of free space above the appliance.

- **DO NOT** place anything on top of the appliance.
- **DO NOT** place on a stove, near gas or electric burners, or in a heated oven.
- **DO NOT** leave the appliance unattended while in use. Extreme caution must be used when moving an appliance containing hot oil or other hot liquids.
- **DO NOT** place anything on top of your air fryer. **DO NOT** store anything inside your air fryer.
- Keep your air fryer away from flammable materials (curtains, tablecloth, etc.). Use on a flat, stable, heat-resistant surface away from heat sources or liquids.
- After using the appliance, the metal cover inside is very hot, avoid contact with it after cooking. Unplug from outlet when not in use and before cleaning. Allow to cool before putting on or taking off parts, and before cleaning the appliance.
- Immediately unplug the appliance if you see dark smoke coming out of the appliance. Wait for the smoke emission to stop, before you remove the pan from the appliance.

# “ KNOWING YOUR AIR FRYER OVEN ”



This appliance must be provided with correct voltage via a professionally installed power socket. Make sure the voltage indicated on the label of the appliance is the same as your local supply.

- DO NOT operate the appliance if the plug, the main cord or the appliance itself is damaged. Always make sure that the plug is inserted properly into a wall outlet.
- DO NOT let the power cord hang over the edge of table or counter. Keep away from hot surfaces.
- DO NOT plug in the appliance or operate the control panel with wet hands.
- NEVER connect this appliance to an external timer switch or separate remote control system in order to avoid a hazardous situation. To disconnect, turn off the appliance, then remove plug from the wall outlet.
- IMPORTANT - This appliance has a polarized plug (one blade is wider than the other). To reduce the risk of electric shock, this plug is intended to fit in a polarized outlet only one way. If the plug does not fit fully in the outlet, reverse the plug. If it still does not fit, contact a qualified electrician. Do not attempt to rig this safety feature.

## FOR HOUSEHOLD USE ONLY READ AND SAVE THESE INSTRUCTIONS



**Regular Check**

**HAVE YOUR AIR FRYER OVEN  
CHECKED REGULARLY  
FOR ANY SIGN OF MALFUNCTION!**

**Check if Plug, cord or appliance is damaged**  
Stop using, check FAQ and contact Paris Rhône Support Team.

# 01

# Oven Body

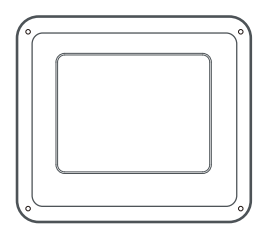
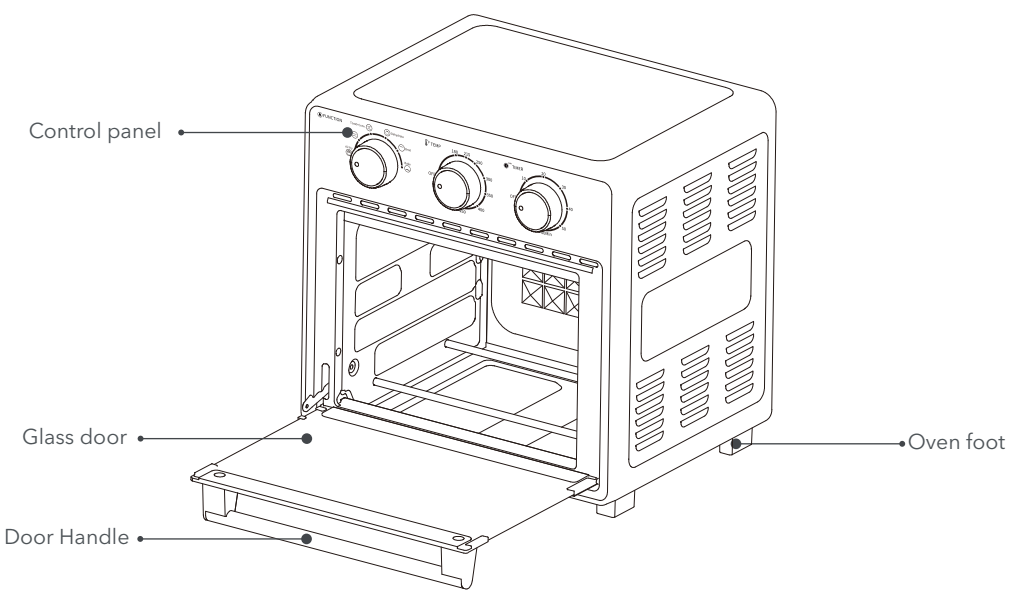

Sheet Pan

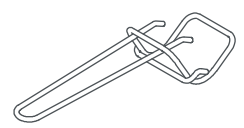

Tray handle

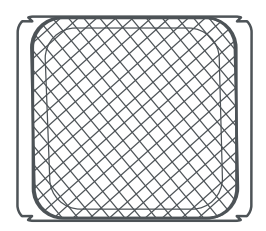

Air Fry Basket

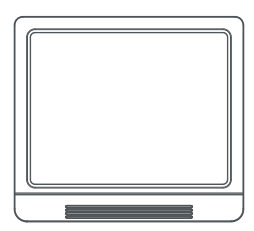

Crumb Tray

|                        |   |
|------------------------|---|
| <p><b>FUNCTION</b></p> | <ul style="list-style-type: none"> <li> Air fryer function</li> <li> Toast function, upper heating + lower heating.</li> <li> Toast+ Convection function, upper heating +lower heating+ Convection</li> <li> Dehydrate function</li> <li> Broil function, upper heating</li> <li> Bake function, lower heating</li> </ul> |
| <p><b>TEMP</b></p>     | <p><b>Temperature Knob</b></p> <p>The temperature from low to high. You could select desired temperature according to the practical situation.</p>  |
| <p><b>TIMER</b></p>    | <p><b>Time Knob</b></p> <p>Any time must keep at "OFF" when cooker not in use. Clockwise turn to choose desired time and it will count down automatically.</p>  |

# USING YOUR AIR FRYER OVEN



# 02

## HOW TO OPERATE

### BEFORE FIRST USE:

1. Place your Airfryer oven on a flat, level surface.
2. When operating the oven, keep at least four inches (ten centimeters) of space on all sides of the oven to allow for adequate air circulation. Do not use on heat-sensitive surfaces.

**NOTE: OBJECTS SHOULD NOT BE STORED ON THE TOP OF THE OVEN. IF THEY ARE, REMOVE ALL OBJECTS BEFORE YOU TURN ON YOUR OVEN. THE EXTERIOR WALLS GET VERY HOT WHEN IN USE. KEEP OUT OF REACH OF CHILDREN.**

3. Check that the Crumb Tray is in place and that there is nothing in the oven.
4. Plug power cord into the wall outlet.
5. Set the temperature, time and heating stage, preheat the oven for 10 minutes. Then insert the baking tray or basket with food.
6. Use either the tray or basket at a time to ensure the food to be cooked better.
7. During cooking, watch the food through the glass door. For thick food, it is better to turn it over once or twice. Use oven mitts to open the oven door. Carefully turn the food and close the oven door immediately.
8. Once cooking is finished, the timer will shut off automatically with bell ring. If the cooking is finished earlier than the set time, please turn back the timer to OFF to power off the oven.
9. Take out of the food carefully.

**CAUTION:** The surfaces of the appliance get hot. To avoid accidental burns, scalping or steam being released while cooking, always open and close the lid by using an oven mitt.

## AIR FRY

This function is ideal for cooking a variety of food, including french fries and chicken wings. Use intense heat and maximized airflow.

1. Place food in the airfryer basket.
2. Insert at top position.
3. Turn the Function knob to  .
4. Turn the Temperature knob to 450°F .
5. Turn the Timer knob to the desired cooking time.
6. When AIRFRY is completed, open door fully and remove food carefully.

## DEHYDRATE

This function combines low and stable heat with steady airflow to evenly dry out foods without cooking. Ideal for drying fruit or vegetable chips.

1. Place the food on the airfryer basket .
2. Insert airfryer basket at mid position, Close the oven door.
3. Turn the Function knob to 
4. Turn the Temperature knob to 180°F.
5. Turn the Timer knob to the desired cooking time. The dehydrate require a longer time, you can turn the TIMER to "STAY ON" position, close supervision is necessary.
6. When dehydrating is completed, open door fully and remove food carefully.

## BAKE

1. Insert the baking tray loaded with food , then close the oven door.
2. Turn the Function knob to 
3. Set baking time and temperature, then baking starts.

## BROIL

1. Insert the basket with food.
2. Keep the door half-open.
3. Turn the Function knob to 
4. Set cooking time and temperature, then cooking starts.

## TOAST

1. Set the temperature to maximum.
2. Insert the basket with food.
3. Turn the Function knob to 
4. Set cooking time and temperature, then cooking starts.

## TOAST+CONVECTION

1. Set the temperature to maximum.
2. Insert the basket with food.
3. Turn the Function knob to 
4. Set cooking time and temperature, then cooking starts.

## Cooking Tips

- Make sure that food does not come into direct contact with the heating elements when cooking.
- Air frying can cause oil and fat to drip from foods. To prevent excess smoke, carefully remove and empty the crumb tray periodically throughout cooking.
- Fresh herbs that are exposed to high heat will wilt and become unappealing. If using fresh herbs to garnish a recipe, try adding them directly after cooking instead.
- To give your food more flavor, use fresh spices and herbs instead of the dried versions. Even something as simple as fresh cracked pepper makes a huge difference!
- Follow food safety guidelines for doneness. Because food sizes can vary, do not rely on recipe timing only when cooking food. Check foods for doneness against current safety guidelines before serving.

Tricks

# CLEANING AND MAINTENANCE



# 03

Proper maintenance will ensure years of service of your product. Clean the product after every use following these steps. This product contains no user serviceable parts and requires little maintenance.

**WARNING:** Unplug the product and allow cooling before cleaning. Clean the interior and exterior surfaces of the appliance with a damp cloth or sponge. Wipe dry with a soft cloth. Do not use abrasive or metallic materials.

1. Unplug the appliance and allow it to cool before cleaning.
2. Do not immerse the appliance in water. All surfaces can be cleaned with a clean damp cloth.
3. If stains still appear, it is recommended to use soap.
4. Do not use abrasive cleaners or sharp utensils to clean the appliance.
5. Clean the interior chamber with a clean damp cloth.

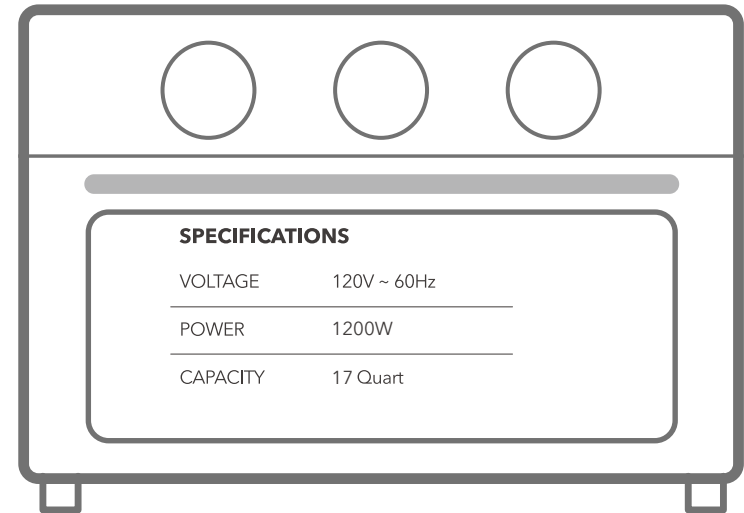

## The air fryer oven does not work

### Remaining odor

### Dark smoke comes out

### White smoke comes out

### Heating elements are not heating up

### Overcooked/ undercooked Foods

### Burnt smell

- Make sure the power cord is securely plugged into the outlet.
- Make sure the oven door is closed properly.
- Plug in another appliance to the same plug to test the circuit.

The first few times you use your air fryer oven, you may notice a plastic smell. This is normal, non-toxic, and goes away quickly. It is recommend to let the oven run for a few minutes before first use.

- Immediately stop cooking and unplug the oven. Allow it to cool to room temperature.
- Remove all accessories from the cooking chamber and clean the area as well as all accessories thoroughly.

- Cooking greasy foods will cause oil to leak into the crumb tray. This oil will produce white smoke. Try not to air fry foods with a high fat content.
- Make sure the drip pan and the inside are cleaned properly and not greasy after each use.

- Make sure the function selector is positioned to the desired cooking setting

- Incorrect timer setting. You may have to adjust the timer to desired position.
- Rack placement. Rack may need to be adjusted to accommodate different foods.

- Food build-up inside appliance, on heating elements or in drip/baking pan. Refer to "Cleaning and Maintenance"



appliancehelp@tyutech.com



Manufacturer: shenzhen Aspiron Technology Company Limited.  
Address: Room 2803B, Building C, Galaxy World Phase II, Minle Community,  
Minzhi Street, Longhua District, Shenzhen, Guangdong, China

Made In China



尺寸：140\*210mm

装订成册

材质：封面157克书纸 内页105克铜版纸